

INCH-POUND

MIL-STD-2088B

29 May 2007

SUPERSEDING

MIL-STD-2088A

09 May 1994

# DEPARTMENT OF DEFENSE DESIGN CRITERIA STANDARD

## BOMB RACK UNIT (BRU), AIRCRAFT



AMSC N/A

FSC 1095

MIL-STD-2088B

FOREWORD

1. This standard is approved for use by all Departments and Agencies of the Department of Defense.

2. Comments, suggestions, or questions on this document should be addressed to: Commander, Naval Air Warfare Center Aircraft Division, Code 491000B120-3, Highway 547, Lakehurst, NJ 08733-5100 or emailed to [thomas.omara@navy.mil](mailto:thomas.omara@navy.mil). Since contact information can change, you may want to verify the currency of this address information using the ASSIST Online database at <http://assist.daps.dla.mil>.

MIL-STD-2088B

CONTENTS

<u>PARAGRAPH</u>	<u>PAGE</u>
1. SCOPE .....	1
1.1 Scope.....	1
1.1.1 International coordination.....	1
2. APPLICABLE DOCUMENTS .....	1
2.1 General.....	1
2.2 Government documents .....	1
2.2.1 Specifications, standards, and handbooks.....	1
2.2.2 Other Government documents, drawings, and publications .....	3
2.3 Non-government publications.....	5
2.4 Order of precedence.....	6
3. DEFINITIONS.....	6
3.1 Aircraft store .....	6
3.2 Bomb Rack Unit (BRU).....	6
3.3 Burst pressure.....	6
3.4 Ejections.....	6
3.5 Flight hours .....	6
3.6 Gravity release .....	7
3.7 Latch .....	7
3.8 Loading .....	7
3.9 Operating cycles.....	7
3.10 Operating hours.....	7
3.11 Pressure vessel .....	7
3.12 Primary release.....	7
3.13 Proof pressure .....	7
3.14 Secondary release.....	7
3.15 Single point safetying .....	7
3.16 Swaybracing.....	7
3.17 Vertical supports .....	7
4. GENERAL REQUIREMENTS .....	7
4.1 BRU types.....	7
4.2 Selection of materials, specifications, standards and drawings .....	8
4.2.1 Materials .....	8
4.2.1.1 Metal parts .....	8
4.2.1.1.1 Heat treatment.....	8
4.2.1.1.2 Castings.....	8
4.2.1.1.3 Forgings .....	8

MIL-STD-2088B

CONTENTS

<u>PARAGRAPH</u>		<u>PAGE</u>
4.2.1.2	Non-metallic components .....	8
4.2.1.2.1	Reinforced plastic and structural composites .....	9
4.2.1.3	Lubrication .....	9
4.2.1.4	Hydraulic fluids .....	9
4.2.1.5	Fungus-proof materials .....	9
4.2.1.6	Potting compounds.....	9
4.2.1.7	Corrosion protection .....	9
4.2.1.8	Finishes .....	9
4.2.1.8.1	Anodizing.....	10
4.2.1.8.2	Chemical surface treatment.....	10
4.2.1.8.3	Plating .....	10
4.2.1.9	Electrical connectors.....	10
4.2.1.10	Wiring .....	10
4.2.1.11	Soldered or brazed connections .....	10
4.2.2	Drawings .....	10
4.3	General design requirements.....	10
4.3.1	BRU to aircraft installation.....	10
4.3.2	Design factors of safety .....	10
4.3.2.1	Yield.....	11
4.3.2.2	Ultimate.....	11
4.3.2.3	Pressure system.....	11
4.3.3	Structural load requirements .....	11
4.3.3.1	Take-off and landing loads .....	11
4.3.3.2	Captive flight loads .....	11
4.3.3.3	Launch loads .....	11
4.3.3.4	Jettison loads.....	11
4.3.3.5	Cyclic loads.....	12
4.3.4	Stress analysis .....	12
4.3.5	Service life .....	12
4.3.6	Reliability.....	12
4.3.7	Shelf life.....	12
4.3.8	Interfaces.....	12
4.3.8.1	BRU to aircraft interface.....	12
4.3.8.2	BRU to store interface .....	12
4.3.8.3	Electrical grounding interface.....	13
4.3.8.3.1	BRU to aircraft structure grounding .....	13
4.3.8.3.2	BRU internal ground interface.....	13
4.3.9	Human engineering.....	13
4.3.10	Environmental and service conditions .....	14

MIL-STD-2088B

CONTENTS

<u>PARAGRAPH</u>		<u>PAGE</u>
4.3.11	Maintainability .....	14
4.3.11.1	Maximum maintenance time.....	15
4.3.11.2	Ejector system maintainability.....	15
4.3.11.2.1	Pyrotechnic BRU .....	15
4.3.11.2.2	Pneumatic or hydraulic BRU .....	15
4.3.11.2.2.1	Pressure vessel .....	15
4.3.11.2.2.2	Removable pressure vessel .....	15
4.3.11.3	Ejector system component maintenance time.....	16
4.3.11.3.1	Pyrotechnic ejection.....	16
4.3.11.3.2	Pneumatic or hydraulic ejection.....	16
4.3.11.4	Maintenance plan .....	16
4.3.11.4.1	Organizational maintenance.....	16
4.3.11.4.1.1	Organizational maintenance tasks.....	16
4.3.11.4.2	Intermediate maintenance .....	17
4.3.11.4.2.1	Intermediate maintenance tasks .....	17
4.4	Interchangeability .....	17
4.5	Identification and marking.....	17
5.	DETAILED REQUIREMENTS .....	17
5.1	Loading of stores.....	17
5.1.1	Support Equipment (SE).....	18
5.1.2	Store vertical support .....	18
5.1.2.1	Vertical support latching.....	18
5.1.2.2	Vertical support latching security .....	22
5.1.3	Store sensing .....	22
5.1.3.1	Store sensing failure mode.....	22
5.1.4	Fuzing and arming control .....	22
5.1.4.1	Mechanical fuze AUs.....	22
5.1.4.2	Electrical fuze AU.....	23
5.1.4.3	Positive arming attachment.....	23
5.1.5	Swaybraces .....	24
5.1.6	Safety interlock .....	24
5.1.6.1	Safety interlock status .....	24
5.1.6.2	Interrupt removal .....	25
5.1.6.3	Alternative interrupt removal.....	25
5.1.6.4	Safety interlock ground operation.....	25
5.1.6.5	Safety interlock control.....	25
5.1.6.6	Safety interlock drive mechanism.....	26
5.1.6.7	Safety interlock override system.....	26

# MIL-STD-2088B

## CONTENTS

<u>PARAGRAPH</u>		<u>PAGE</u>
5.1.6.8	Additional release operation interrupts.....	27
5.1.7	Store release and ejection system .....	27
5.1.7.1	Gravity release BRUs .....	27
5.1.7.2	Pyrotechnic actuated BRUs .....	27
5.1.7.2.1	Cartridges.....	27
5.1.7.2.2	Cartridge firing pin .....	28
5.1.7.2.3	Cartridge breech.....	28
5.1.7.3	Pneumatic/hydraulic activated BRUs .....	29
5.1.7.3.1	Pneumatic interface.....	31
5.1.7.3.2	Pneumatic activated BRUs with removable energy source .....	31
5.1.7.4	Ejection force .....	31
5.1.7.5	Separation parameters.....	32
5.1.7.6	Ejector pistons.....	32
5.1.8	Safety in design.....	32
5.1.8.1	BRU safety program .....	32
5.1.8.1.1	Safety program functions.....	32
5.1.8.1.2	Failure modes, effects and criticality analysis .....	33
5.1.8.1.3	Inadvertent release .....	33
5.1.8.1.4	Locked shut functioning .....	33
5.1.8.1.5	Driven items.....	33
5.1.8.1.6	Impulse cartridges.....	33
5.1.8.1.7	Pneumatic or hydraulic BRU safety requirements.....	33
5.1.9	Electromagnetic environmental effects (E <sup>3</sup> ) .....	34
5.1.9.1	Electromagnetic compatibility (EMC) program .....	34
5.1.9.2	Electromagnetic interference (EMI) .....	34
5.1.9.2.1	Electromagnetic pulse (EMP) .....	34
5.1.9.3	Electromagnetic vulnerability EMV .....	34
5.1.9.4	Lightning protection.....	34
5.1.9.5	Bonding and grounding.....	34
5.1.9.6	Wiring and cabling.....	34
5.1.9.7	Static electricity .....	34
5.1.9.8	Hazards of electromagnetic radiation to ordnance (HERO).....	35
5.1.9.9	Coupling factory (CF).....	35
5.2	Electrical requirements .....	35
5.2.1	General.....	35
5.2.2	BRU structural ground.....	35
5.2.3	Nose arm .....	35
5.2.4	Center arm.....	35
5.2.5	Tail arm.....	35

MIL-STD-2088B

CONTENTS

<u>PARAGRAPH</u>		<u>PAGE</u>
5.2.6	Electrical fuzing .....	36
5.2.7	Primary release command.....	36
5.2.7.1	Impulse cartridge .....	36
5.2.7.2	Solenoid release .....	36
5.2.8	Secondary release command.....	36
5.2.9	Auxiliary release command .....	36
5.2.10	Safety interlock electrical requirements.....	36
5.2.10.1	Safety interlock mechanism status.....	36
5.2.10.2	Safety interlock drive mechanism electrical power .....	36
5.2.10.3	Safety interlock override status.....	37
5.2.10.4	Cartridge actuated device (CAD) override control.....	37
5.2.11	Vertical support status.....	37
5.2.12	BRU presence status .....	37
5.2.13	Store sensing signal.....	37
5.2.14	BRU power/master arm .....	37
6.	NOTES .....	37
6.1	Intended use .....	37
6.2	Subject term (key word) listing.....	37
6.3	International standardization agreement implementation.....	38
6.4	Changes from previous issue .....	38
	CONCLUDING MATERIAL .....	39
	<u>FIGURE</u>	
1.	14-inch vertical support spacing Type I, two-piston bomb rack unit (BRU) geometric relationships .....	19
2.	14/30-inch vertical support spacing type II, two-piston bomb rack unit (BRU) geometric relationships .....	20
3.	14-inch vertical support spacing Type I, single-piston bomb rack unit (BRU) geometric relationships .....	21
4.	Wiring schematic to achieve primary and secondary release .....	28
5.	Initiation circuits to activate redundant energy source control devices.....	31
	<u>TABLE</u>	
I.	Carriage characteristics of BRU types.....	8
II.	Paragraphs containing international standardization agreements.....	38

## 1. SCOPE

1.1 Scope. This standard establishes the general guidelines and criteria for the design and development of a single store bomb rack unit (BRU) for carriage and release of airborne stores (excluding air-to-air missiles) on 14 or 30-inch suspensions from fixed wing and rotary wing aircraft. This standard also addresses detailed requirements for gravity, pyrotechnic, hydraulic, and pneumatic powered BRUs. Mechanical aircraft armament interoperable interfaces are incorporated to enhance cross utilization and servicing capabilities between military aircraft and aircraft stores (see 3.1) of all services of the Department of Defense (DOD) and North Atlantic Treaty Organization (NATO) nations.

1.1.1 International coordination. Included in this standard are certain DOD acceptable interface configurations which are approved or currently undergoing international coordination and are incorporated into appropriate International standardization documents (see 6.4).

## 2. APPLICABLE DOCUMENTS

2.1 General. The documents listed in this section are specified in sections 4 or 5 of this standard. This section does not include documents cited in other sections of this standard or recommended for additional information or as examples. While every effort has been made to ensure the completeness of this list, document users are cautioned that they must meet all specified requirements of documents cited in sections 4 or 5 of this standard, whether or not they are listed.

### 2.2 Government documents.

2.2.1 Specifications, standards, and handbooks. The following specifications, standards, and handbooks form a part of this document to the extent specified herein. Unless otherwise specified, the issues of these documents are those cited in the solicitation or contract.

### INTERNATIONAL STANDARDIZATION AGREEMENTS

STANAG 3575 AA	- Aircraft Stores Ejector Racks
AIR STD 20/10	- Ejector Release Units for Aircraft Stores
AIR STD 20/17	- Mechanical Connectors Between Stores and Suspension Equipment for Arming and Associated Functions of Stores
AIR STD 20/18	- Environmental Test Methods for Aircraft Stores Suspension and Release Equipment

(Copies of the above STANAGs and AIR STDs are under controlled distribution. Information may be obtained from the Air Force International Standardization Office, HQ

## MIL-STD-2088B

USAF/XOXX-ISO, 1101 Wilson Blvd., Suite 1015, Arlington, VA 22209-2211 or email to [ascmcus@pentagon.af.mil](mailto:ascmcus@pentagon.af.mil))

### FEDERAL SPECIFICATION

- L-P-383 - Plastic Material, Polyester Resin, Glass Fiber Base, Low Pressure Laminated

### COMMERCIAL ITEM DESCRIPTION (CID)

- A-A-59503 - Nitrogen, Technical

### DEPARTMENT OF DEFENSE SPECIFICATIONS

- MIL-S-5002 - Surface Treatments and Inorganic Coatings for Metal Surfaces of Weapon Systems. (Inactive for New Design)
- MIL-DTL-5541 - Chemical Conversion Coatings on Aluminum and Aluminum Alloys
- MIL-T-7743 - Testing, Store Suspension and Release Equipment, General Specification for
- MIL-A-8625 - Anodic Coatings for Aluminum and Aluminum Alloys
- MIL-I-8671 - Installation of Droppable Stores and Associated Release Systems
- MIL-DTL-15024 - Plates, Tags and Bands for Identification of Equipment, General Specification for
- MIL-DTL-18307 - Nomenclature and Identification for Aeronautical Systems Including Joint Electronics Type Designated Systems and Associated Support Systems
- MIL-PRF-46010 - Lubricant, Solid Film, Heat Cured, Corrosion Inhibiting
- MIL-D-81303 - Design and Evaluation of Cartridges for Stores Suspension Equipment
- MIL-DTL-81706 - Chemical Conversion Materials for Coating Aluminum and Aluminum Alloys
- MIL-C-81842 - Connector Assemblies for Bomb Rack Electric Fuzing Provisions
- MIL-PRF-83282 - Hydraulic Fluid, Fire Resistant, Synthetic Hydrocarbon Base, Metric, NATO Code Number H-537

## MIL-STD-2088B

### DEPARTMENT OF DEFENSE STANDARDS

MIL-STD-130	- Identification Marking of U.S. Military Property
MIL-STD-461	- Requirements for the Control of Electromagnetic Interference Characteristics of Subsystems and Equipment
MIL-STD-464	- Electromagnetic Environmental Effects Requirements for Systems
MIL-STD-704	- Aircraft Electric Power Characteristics
MIL-STD-810	- Environmental Engineering Considerations and Laboratory Tests
MIL-STD-882	- System Safety
MIL-STD-889	- Dissimilar Metals
MIL-STD-1472	- Human Engineering
MIL-STD-7179	- Finishes, Coatings, and Sealants, for the Protection of Aerospace Weapons Systems
MIL-STD-8591	- Airborne Stores, Suspension Equipment and Aircraft-Store Interface (Carriage Phase)

### DEPARTMENT OF DEFENSE HANDBOOKS

MIL-HDBK-17/1	- Composite Materials Handbook Volume 1, Polymer Matrix Composites Guidelines for Characterization of Structural Materials
MIL-HDBK-454	- General Guidelines for Electronic Equipment
MIL-HDBK-838	- Lubrication of Military Equipment
MIL-HDBK-1568	- Materials and Processes for Corrosion Prevention and Control in Aerospace Weapons Systems
JSSG-2006	- Aircraft Structures
MIL-HDBK-46855	- Human Engineering Program Process and Procedures

(Copies of the above specifications, standards, and handbooks are available online at <http://assist.daps.dla.mil/quicksearch/> or <http://assist.daps.dla.mil> or from the Standardization Document Order Desk, Building 4D, 700 Robbins Avenue, Philadelphia, PA 19111-5094.)

2.2.2 Other Government documents, drawings, and publications. The following other Government documents, drawings, and publications form a part of this document to the extent specified herein. Unless otherwise specified, the issues of these documents are those cited in the solicitation or contract.

MIL-STD-2088B

DRAWINGS

NAVAL AIR SYSTEMS COMMAND (NAVAIR)

923AS190 - Swivel and Ring Assembly, MAU-182

(Copies of the above drawing are available from the Naval Air Technical Data and Engineering Service Command (NATEC), P.O. Box 357031, NASNI, Bldg. 90, San Diego, CA 92135-7031 or email to: [nani\\_governmentdrawings@navy.mil](mailto:nani_governmentdrawings@navy.mil).)

NAVAL SEA SYSTEMS COMMAND (NAVSEA)

2263759 - Latch, Spring Assembly

(Copies of the above drawing are available from the Naval Ordnance Station (Code 802), Louisville, KY 40214-5001.)

PUBLICATIONS

DEPARTMENT OF TRANSPORTATION (DOT)

DOT/FAA/AR-MMPDS - Metallic Materials Properties Development and Standardization

NAVAIR AIR SYSTEMS COMMAND (NAVAIR)

AR-43 - Electromagnetic Compatibility Advisory Board; Requirement for  
SD-24 - General Specification for Design and Construction of Aircraft Weapon Systems  
WS-2081 - Switch, Arming Safety, Mark 122 Mod 0

(Copies of the above documents are available from the Naval Air Systems Command, Standardization Section (AIR-4.1C), Building 2185, 22347 Cedar Point Road, Patuxent River, MD 20670.)

U.S. ARMY

ADS-37A-PRF - Electromagnetic Environmental Effects (E<sup>3</sup>), Performance and Verification Requirements  
ADS-45-HDBK - Data and Test Procedures for Airworthiness

MIL-STD-2088B

- Natick TR-89/044
- Release for U.S. Army Helicopter Armament Testing (Guns, Rockets, Missiles)
  - 1988 Anthropometric Survey of U.S. Army Personnel: Methods and Summary Statistics

(Copies of the above documents are available from AMSAM-RA-IM-IS-IL, Bldg. 5300 Sparkman Center, Redstone Arsenal, AL 35898-5000 or [www.redstone.army.mil/foia/](http://www.redstone.army.mil/foia/).)

2.3 Non-government publications. The following documents form a part of this document to the extent specified herein. Unless otherwise specified, the issues of these documents are those cited in the solicitation or contract.

AMERICAN SOCIETY OF MECHANICAL ENGINEERS (ASME)

- ASME-Y14.100
- Engineering Drawing and Related Documentation Practices

(Copies of these documents are available online at <http://www.asme.org> or from the American Society of Mechanical Engineers, P.O. Box 2300, Fairfield, NJ 07007-2300.)

AMERICAN WELDING SOCIETY (AWS)

- AWS-C3.4
- AWS-C3.5
- AWS-C3.6
- AWS-C3.7
- Torch Brazing
  - Induction Brazing
  - Furnace Brazing
  - Aluminum Brazing

(Copies of these documents are available from the American Welding Society, 550 N.W. LeJeune Road, Miami, FL 33126 or <http://www.aws.org>.)

SOCIETY OF AUTOMOTIVE ENGINEERS (SAE) INTERNATIONAL

- SAE-AMS-QQ-A-367
- SAE-AMS2175
- SAE-AMS4931
- SAE-AMS4965
- SAE-AMS-H-6088
- SAE-AMS-H-6875
- SAE-AMS-F-7190
- Aluminum Alloy Forgings
  - Casting, Classification and Inspection of Titanium Alloy Bars, Forgings, and Rings 6Al-4V Extra Low Interstitial (ELI) Duplex Annealed, Fracture Toughness
  - Titanium Alloy Bars, Wire, Forgings, and Rings 6.0Al-4.0V Solution Heat Treated and Aged
  - Heat Treatment of Aluminum Alloys
  - Heat Treatment of Steel Raw Material
  - Forging, Steel, for Aircraft/Aerospace Equipment and Special Ordnance Applications

## MIL-STD-2088B

SAE-AMS-T-9047	- Titanium and Titanium Alloy Bars (Rolled or Forged) and Reforging Stock, Aircraft Quality
SAE-AMS-A-21180	- Aluminum Alloy Castings, High Strength
SAE-AMS-A-22771	- Aluminum Alloy Forgings, Heat Treated
SAE-AS50881	- Wiring, Aerospace Vehicle
SAE-AMS-H-81200	- Heat Treatment of Titanium and Titanium Alloys

(Copies of these documents are available online at <http://www.sae.org> or from the Society of Automotive Engineers, 400 Commonwealth Drive, Warrendale, PA 15090.)

2.4 Order of precedence. In the event of a conflict between the text of this document and the references cited herein, the text of this document takes precedence. Nothing in this document, however, supersedes applicable laws and regulations unless a specific exemption has been obtained.

### 3. DEFINITIONS

3.1 Aircraft store. Any device intended for internal or external carriage and mounted on aircraft suspension and release equipment, whether or not the item is intended to be separated in flight from the aircraft. Aircraft stores are classified in two categories as follows:

a. Expendable store. An aircraft store normally separated from the aircraft in flight such as a missile, rocket, bomb, nuclear weapon, mine, torpedo, pyrotechnic device, sonobuoy, signal underwater sound device, cargo drop container, drone, and other similar items.

b. Non-expendable store. An aircraft store that is not normally separated from the aircraft in flight such as a tank (fuel and spray), line source disseminator, pod (refueling, thrust augmentation, gun, electronic-countermeasure, data link), multiple rack, target, and other similar items.

3.2 Bomb Rack Unit (BRU). Suspension equipment used for carrying aircraft store(s) that incorporates a method of separating the aircraft store from the aircraft at the time of commanded release.

3.3 Burst pressure. Design test pressure aimed to verify the structural integrity of the pressure system. Permanent deformation and leakage are permitted when burst pressure is applied, but no sudden ruptures or detachment of parts are allowed.

3.4. Ejections. The number of powered store releases or separations.

3.5 Flight hours. The number of hours accumulated in the airborne condition.

## MIL-STD-2088B

3.6 Gravity release. The mode wherein an aircraft store is intentionally separated from aircraft suspension and release equipment and the applied separation force is the force of gravity only.

3.7 Latch. Those mechanisms that engage the BRU vertical supports to retain the store.

3.8 Loading. An operation that installs aircraft stores on the aircraft.

3.9 Operating cycles. The number of store loading/off-loading events, including manual.

3.10 Operating hours. The number of hours accumulated in a status implying a degree of stress or an active operating condition (i.e. store restraint for mechanical components, generation of/being subjected to electric or electromechanical forces for electrical and electromechanical components, pressurization for pneumatic or hydraulic components, etc.).

3.11 Pressure vessel. A storage tank or container that has been designed to operate with a liquid (e.g. hydraulic fluid) or gas (e.g. air) under pressure greater than atmospheric pressure.

3.12 Primary release. The principal provision for safe separation of stores or suspension items (or both) from the aircraft.

3.13 Proof pressure. Design test pressure aimed to verify the functional and structural integrity of the pressure system. Neither permanent deformation nor leakage is allowed when proof pressure is applied.

3.14 Secondary release. The emergency provision for safe separation of stores or suspension items (or both) from the aircraft.

3.15 Single point safetying. Changing from a state of readiness for initiation to a safe condition from one location.

3.16 Swaybracing. That mechanism within the physical tri-axial restraint system which partially or totally reacts to store yaw and pitching moment in addition to vertical and lateral store loads.

3.17 Vertical supports. The structural mating members of the BRU to the store. Typically hooks have been used to accomplish this function.

## 4. GENERAL REQUIREMENTS

4.1 BRU types. Carriage characteristics of BRU types are shown in Table I.

MIL-STD-2088B

TABLE I. Carriage characteristics of BRU types.

Type	Vertical support spacing	Maximum carriage mass
I	14-inch	1450 lbs
II	14/30-inch	1450 lbs for 14-inch 5000 lbs for 30-inch

4.2 Selection of materials, specifications, standards and drawings. The selection of materials, standard parts, processes, corrosion protection, and design features significant in corrosion behavior shall be in accordance with the guidelines of SD-24.

4.2.1 Materials. Materials shall conform to applicable specifications, be compatible with conditions of 4.3.10, and shall be as specified herein and on applicable drawings. Design shall make maximum use of standard (such as MS, AN, SAE, and MIL-DTL/PRF) parts, materials and processes, rather than special or peculiar items. Materials that are not covered by government specifications or that are not specifically described herein shall be of the best quality, suitable for the purpose intended. Particular care shall be given to close-fitting parts in the choice of both materials and corrosion prevention methods. Materials should be selected such that wet lubricants or preservatives are not required. Particular care shall be taken to minimize the use of ozone depleting materials or coatings, and toxic materials such as cadmium or chrome plating.

4.2.1.1 Metal parts. All metal parts shall be of the corrosion resistant type or treated in a manner to render them resistant to corrosion. Type 431 corrosion resistant steel shall not be used. Unless protected against electrolytic corrosion, dissimilar metals, as specified in MIL-STD-889, shall not be used in contact with each other. General design information governing usage of metals shall be as provided in DOT/FAA/AR-MMPDS.

4.2.1.1.1 Heat treatment. Heat treatment of aluminum, steel, and titanium parts shall be in accordance with SAE-AMS-H-6088, SAE-AMS-H-6875, and SAE-AMS-H-81200 respectively.

4.2.1.1.2 Castings. Castings shall conform to the requirements of SAE-AMS2175 with appropriate class, grade, and critical area notations. Aluminum alloy castings, used in critical strength applications, shall conform to the requirements of SAE-AMS-A-21180.

4.2.1.1.3 Forgings. Forgings shall conform to the requirements of SAE-AMS-F-7190, SAE-AMS4931, SAE-AMS4965, SAE-AMS-T-9047, or SAE-AMS-QQ-A-367 with appropriate grade and grain flow notations. Forgings, used in critical strength applications, shall conform to the requirements of SAE-AMS-F-7190 Grade A or SAE-AMS-A-22771.

4.2.1.2 Non-metallic components. Non-metallic components shall be designed for minimum deterioration caused by abrasion, exposure to sunlight, microorganisms, moisture,

## MIL-STD-2088B

temperature extremes, fuel, hydraulic and lubricating oil, grease, and salt spray. Protection shall be provided for those non-metallic components that can endanger or jeopardize the function of the BRU due to strength degradation associated with abrasion, load or exposure-induced deterioration.

4.2.1.2.1 Reinforced plastic and structural composites. The use of structural composites and/or plastic, if required, shall be as specified for Type-I materials in L-P-383 or meet the applicable requirements for fibrous composite construction in JSSG-2006. MIL-HDBK-17/1 shall be used where applicable for material and fabrication processing guidelines. The material and configuration design shall be of such character and quality as to be capable of withstanding all service conditions, as specified herein, without degrading the performance of other components of the BRU or surrounding materials.

4.2.1.3 Lubrication. Lubricants and lubrication practices shall conform to the requirements of MIL-HDBK-838 and MIL-PRF-46010. Lubricants shall function satisfactorily throughout the temperature range from -70 to +200 °F. Choice of lubricants shall: (a) be compatible with non-metallic components, (b) not damage finishes adjacent to location of lubricant application, and (c) eliminate the need for frequent lubrication by field maintenance activities. If lubrication is required, choice of lubricants and practices shall be such that lubrication need be accomplished only during post deployment intermediate level maintenance (see 4.3.11.4.2).

4.2.1.4 Hydraulic fluids. Hydraulic fluids used in the BRU shall be in accordance with MIL-PRF-83282.

4.2.1.5 Fungus-proof materials. The materials used in the BRU shall be non-nutrients for fungi.

4.2.1.6 Potting compounds. Potting compounds shall comply with MIL-HDBK-454, Guideline 47, Encapsulation and Embedment (Potting).

4.2.1.7 Corrosion protection. Corrosion protection practices employed shall be in accordance with the MIL-STD-7179 requirements for exterior surfaces. Design shall make use of materials which preclude corrosion susceptibility under service environmental conditions without a requirement for hermetic sealing. Materials and processes for corrosion prevention shall meet the requirements of MIL-HDBK-1568.

4.2.1.8 Finishes. Protective coatings and finishes shall not crack, chip, or scale during normal service, or in the herein specified extremes of environmental conditions. Surface treatments, coatings, and finishes shall conform to MIL-S-5002 or surface treatments specified herein.

## MIL-STD-2088B

4.2.1.8.1 Anodizing. All non-fatigue critical aluminum and aluminum alloy parts, not subject to wear, shall have anodic coatings in accordance with MIL-A-8625, type II. Aluminum and aluminum alloy parts subject to wear shall have anodic coatings in accordance with MIL-A-8625, type III. On components where anodizing is detrimental to performance, MIL-DTL-81706 shall be used.

4.2.1.8.2 Chemical surface treatment. For aluminum and aluminum alloy parts not subject to wear, abrasion, or corrosion, chemical conversion surface treatment in accordance with MIL-DTL-5541 may be used in lieu of anodizing.

4.2.1.8.3 Plating. Plating should be avoided. However, when required, plating of steel surfaces shall be in accordance with the requirements of MIL-S-5002 or MIL-STD-7179. Steel parts, not subject to wear, in contact with aluminum or aluminum alloys, shall be treated to prevent galvanic action, in accordance with the requirements of MIL-STD-7179.

4.2.1.9 Electrical connectors. The connectors shall contain positive mating features to indicate completed connection and to prevent accidental shorting of or damage to contacts during mating of the plug and receptacle. Connectors shall contain peripheral grounding fingers that connect the two mating halves of the connector before pin and socket contacts make connection. The connector shall also contain provisions for terminating shield braid for electromagnetic interference protection. The aircraft, weapon and BRU sides of the electrical connection shall contain socket-type contacts and the electrical adapter harness shall contain pin-type contacts. If there is no electrical adapter harness, then the aircraft or BRU side of the electrical connection shall contain socket-type contacts, and the weapon side shall contain pin-type contacts.

4.2.1.10 Wiring. All electrical wiring shall be selected and installed in accordance with SAE-AS50881.

4.2.1.11 Soldered or brazed connections. The soldering of contacts shall be in accordance with MIL-HDBK-454, Guideline 5, Soldering. When a brazing process is used, it shall be in accordance with AWS-C3.4, 3.5, 3.6, 3.7.

4.2.2 Drawings. Drawings shall be in accordance with ASME-Y14.100.

4.3 General design requirements.

4.3.1 BRU to aircraft installation. The BRU to aircraft installation shall not require any special tools or equipment for mating and attachment.

4.3.2 Design factors of safety.

## MIL-STD-2088B

4.3.2.1 Yield. The BRU yield load shall be 1.15 times the design limit load. No permanent deformation shall be allowed after application of the yield load.

4.3.2.2 Ultimate. The BRU ultimate load shall be 1.50 times the design limit load. Failure of the BRU, upon application of the ultimate load, shall be defined as:

- a. Separation of the store from the BRU, or
- b. Separation of the BRU from the aircraft.

Other structural breakage or permanent deformation of the BRU shall not constitute failure at the ultimate load level.

### 4.3.2.3 Pressure system.

a. Hydraulic system. Components of the pressure system exposed to hydraulic pressure shall be designed to a minimum proof pressure of 1.15 and a minimum burst pressure of 1.5 times the operational peak pressure of that system.

b. Gas system (hot and cold). Components of the pressure system exposed to gas pressure shall be designed to a minimum proof pressure of 1.5 and a minimum burst pressure of 2.5 times the operational peak pressure of that system.

4.3.3 Structural load requirements. Load analyses shall be conducted to determine the design loads.

4.3.3.1 Take-off and landing loads. The BRU shall withstand the maximum loads imposed by catapult take-off and arrested landing in accordance with MIL-STD-8591. Applicable inertial acceleration limits and loads shall be developed.

4.3.3.2 Captive flight loads. The BRU shall be designed for the maximum aerodynamic and inertial loads acting on the store and BRU throughout the captive flight Mach-altitude envelope of the aircraft (minimum store configuration). The design captive flight envelope and the inertial acceleration levels of the most severe aircraft/weapon station shall be used to develop worst-case BRU design loads in accordance with MIL-STD-8591.

4.3.3.3 Launch loads. The BRU shall be designed for the maximum aerodynamic and inertial loads acting on the store and BRU throughout the specified launch Mach-altitude envelope of the aircraft (minimum store configuration). Combined BRU loads shall include BRU ejector forces and the structural dynamic interactions which occur at store separation.

4.3.3.4 Jettison loads. The BRU shall be designed to withstand the combined effect of maximum ejection forces and the aerodynamic and inertial forces acting on the store/BRU combination over the specified jettison envelope.

4.3.3.5 Cyclic loads. The BRU shall be capable of withstanding the cyclic application of combined limit loads imposed upon it over the course of its specified life. The cyclic load spectra shall include the effects of specified environments and a minimum of 500 launches.

4.3.4 Stress analysis. A stress analysis shall be accomplished by using the loads generated in accordance with 4.3.3. Calculated margins of safety less than 0.33 for cast items shall be demonstrated by structural test. Critical margins of safety shall be made available to the procuring activity.

4.3.5 Service life. The BRU design objective shall be to meet or exceed an economically maintainable service life of: "a" flight hours, or "b" ejections, or "c" operating hours, or "d" operating cycles, whichever occurs first. An economically maintainable service life is exceeded when the cost to repair the BRU is greater than one-half the replacement cost.

“a” - 6,000 or as specified by the procuring activity

“b” - 500 or as specified by the procuring activity

“c” - 9,000 or as specified by the procuring activity

“d” - 2,000 or as specified by the procuring activity

4.3.6 Reliability. Mission reliability for a BRU shall be a minimum of 0.99. Mission reliability is the probability that the BRU will successfully eject stores within specified mission parameters.

4.3.7 Shelf life. Shelf life of the BRU and all components shall be a minimum of five years and shall be refurbishable following the minimum shelf life specified. Exclusive of shelf life, the service life of the BRU shall be a minimum of 10 years. A maximum number of parts shall have an indefinite shelf life and a service life not less than that of the BRU.

#### 4.3.8 Interfaces.

4.3.8.1 BRU to aircraft interface. The BRU to aircraft interface shall be dependent on aircraft design and airframe backup structure to distribute the BRU stores load. The BRU mounting shall optimize the aircraft performance envelope, minimize weight and drag, and utilize optimum load paths. Design shall be tailored to existing aircraft support structure and shall provide ease of installation and removal. Physical interfaces between the BRU and the aircraft shall be defined in terms of dimensions and tolerances. Functional interfaces shall include the support, service, and ejection functions. Electrical interfaces shall specify BRU power and signal requirements. All interface requirements shall comply with aircraft interface specifications.

4.3.8.2 BRU to store interface. Interface between the BRU and store shall include stores support, retention and the pre-release, release, and service functions. Physical interfaces

including safe-arm mechanisms shall be specified in terms of dimensions and tolerances under both static and dynamic conditions. Grounding and shielding shall be provided. All interface requirements shall comply with aircraft interface specifications.

4.3.8.3 Electrical grounding interface.

4.3.8.3.1 BRU to aircraft structure grounding. The BRU structure shall be electrically grounded to the aircraft structure through the physical, mechanical interface of the two structures. The preparation of the conducting path and choice of mating surfaces composition, material, and electrical characteristics shall be available to the procuring activity.

4.3.8.3.2 BRU internal ground interface. An isolated common ground pin for the BRU and weapon electrical components shall be provided in the BRU to which each aircraft power source ground shall tie. The power return wires shall be twisted with the supply wires and the twist should be approximately 155 twists per meter.

4.3.9 Human engineering. Human engineering shall comply with MIL-STD-1472, MIL-HDBK-46855, and the following additional requirements:

- a. The BRU shall be operable and maintainable by a range of personnel from the 5th percentile female through the 95th percentile male, for critical body dimensions and strength characteristics, attired in personal and protective clothing and equipment. Anthropometric data for the 5th and 95th percentile armament ground crew shall be as specified in Natick TR-89/044.
- b. The BRU shall be handled, serviced, and transported outside of the aircraft installation without any requirement for ancillary equipment, such as carriers, bolts, and crates.
- c. Any positional indication and instructions located externally shall be flush with the general outside surface.
- d. All normal BRU functional operations shall be performed without the use of special tools.
- e. Ready access to functions, operations, and indications, such as, but not limited to, cartridge installation, pneumatic vessel installation, latching, loading, locking, and stray voltage checks shall be made available.
- f. No components shall be accessible externally which would initiate accidental or inadvertent operation of the BRU.
- g. All operation of the BRU shall require no greater than two people at any one time.

## MIL-STD-2088B

h. All services and normal function operations shall be accessible with the BRU latched and store restrained.

i. Criteria shall be applied to the design to: (1) ensure that the equipment can be efficiently, safely, and reliably maintained and operated; (2) ensure that adequate handling provisions have been included; (3) minimize human error-type failures; (4) ensure that design features will not constitute a hazard to personnel.

j. Early design effort shall include identification of human factor variables, which are most likely to require detailed study or research during later design stages, such as human performance requirements which may exceed human capabilities, degrade system objective, reflect possible unsafe practices, or may be prone to human error.

k. Access with sufficient internal space shall be provided for servicing and adjusting.

l. The design of the BRU shall have no protrusions or critically located components that could easily be damaged by normal handling or normal operation of the BRU outside of a shipping container.

4.3.10 Environmental and service conditions. The BRU shall meet the environmental requirements of MIL-STD-810 and MIL-T-7743 (AIR STD 20/18), as applicable, and shall function under any or all combinations of the following general operating conditions:

a. Altitude: From sea level to 70,000 feet.

b. Temperature: From -70 to +200 °F. Transient temperatures are to be determined by the applicable aircraft detail specification.

c. Humidity: Under all conditions of relative humidity at temperatures from -70 to +200 °F.

d. High-g, vibration, and shock: Under all conditions of high-g, vibration, and shock that are present in the aircraft during service operation.

e. Contaminants: Under all conditions of service or storage.

4.3.11 Maintainability. The only scheduled maintenance the BRU shall require is preflight and post flight checkout and cleaning and the replacement of consumable items and associated services. The BRU shall be designed with sufficient simplicity to permit adjustments, repairs, and replacement of consumable goods and with component accessibility that requires a minimum of maintenance effort and facilities at all maintenance levels. The design shall provide for ease of assembly and disassembly with a minimal need for removal of hardware and special tools, test facilities and other support equipment for servicing. Design modularity of components shall be

maximized for ease of replacement with minimum requirements for special skills. The module replacement concept shall be employed.

4.3.11.1 Maximum maintenance time. With the BRU removed from the aircraft, the design shall provide for a mean-time-to-repair (MTTR) the BRU of one hour and a two hour maximum to include fault isolation to the component level, replacement of the failed component, and checkout.

4.3.11.2 Ejector system maintainability.

4.3.11.2.1 Pyrotechnic BRU. If impulse cartridges are used as release and ejection energy sources, the BRU design shall provide for:

a. Internal breech cleaning without removal of BRU assembly from the aircraft and without the use of special support equipment. BRU breech component removal shall be minimized to facilitate cleaning at the organizational maintenance level.

b. Breech installation and removal with a minimum of maintenance effort.

c. A means other than removal of the breech cap or movement of the electrical connection to indicate cartridge installation.

d. A positive retention feature shall be provided to maintain cartridge containers/breech caps in a secure position during flight.

4.3.11.2.2 Pneumatic or hydraulic BRU.

4.3.11.2.2.1 Pressure vessel. If a pressure vessel is used as the release/ejection energy source, its design shall provide for:

a. A visual indication of the internal pressure level (not dependent on electrical power availability).

b. A means to manually relieve the vessel internal pressure.

4.3.11.2.2.2 Removable pressure vessel. If a removable pressure vessel is used as the release/ejection energy source, its design, in addition to the previous requirements, shall comply with the following requirements:

a. It shall be possible to install/remove the vessel without using special tools.

b. It shall be possible to install/remove the vessel with the store fully latched to the BRU.

- c. It shall be possible to install/remove the vessel regardless of its pressurization status.
- d. In the case where the above requirement c is not fulfilled, it shall not be possible to install/remove the vessel unless its internal pressure has been relieved.

4.3.11.3 Ejector system component maintenance time.

4.3.11.3.1 Pyrotechnic ejection. The total servicing time for the cleaning of designated BRU ejector components, related to firing, should be 0.33 man-hour (20 man-minutes) maximum (see 4.3.11.4.1.1). If cartridges are employed, the maximum time for removal or installation of cartridges shall be not greater than 2 man-minutes per cartridge. Items requiring only periodic replacement, such as screens, filters, and/or desiccant canisters are not considered within this cleaning time constraint, but shall be removable/replaceable in 0.50 man-hour (30 man-minutes) maximum.

4.3.11.3.2 Pneumatic or hydraulic ejection. The time needed to charge a pressure vessel shall be stated by the procuring activity, differentiating between:

- a. Aircraft on ground (with internal pressure generation)
- b. Aircraft on ground (with external pressure generation)
- c. Aircraft in flight (with internal pressure generation)

If a removable reservoir or accumulator is used, the procuring activity shall specify the maximum time for vessel removal or installation (shall be not greater than 4 man-minutes).

4.3.11.4 Maintenance plan. The BRU shall be designed to be maintained at the organizational and intermediate levels of maintenance.

4.3.11.4.1 Organizational maintenance. Maintenance tasks performed at this level will be confined primarily to servicing and checkout of the BRU and shall be performed on a day-to-day basis.

4.3.11.4.1.1 Organizational maintenance tasks. Design shall allow for maintenance at this level to consist of the following:

- a. Preflight and post-flight operations such as visual inspection, cleaning, servicing, and mechanical checkout. The ejector system shall not require cleaning or servicing prior to 50 ejections or 30 days whichever occurs first.

## MIL-STD-2088B

b. The BRU shall provide for a non-hazardous means for an electrical functional check of the energy release control device. Troubleshooting and testing shall be conducted with the BRU mounted on the aircraft.

c. Removal and replacement of designated components without requirements for alignment and adjustment or special tools.

4.3.11.4.2 Intermediate maintenance. Design shall allow for maintenance tasks performed at this level to be confined to support of organizational activities.

4.3.11.4.2.1 Intermediate maintenance tasks. Intermediate maintenance tasks shall consist of the following:

a. Inspection: visual and dimensional inspections to determine corrosion damage and other defects reported by the organizational maintenance activity that would prevent re-use.

b. Repair by adjustment, servicing, and replacement of components, assemblies, and subassemblies not within the capabilities of organizational maintenance.

c. Checkout: electrical or mechanical functions.

4.4 Interchangeability. All parts having the same part number shall be functionally and dimensionally interchangeable regardless of manufacturer. The item identification, manufacturer's part number, and part number requirements of ASME-Y14.100 shall govern the part numbers and changes thereto.

4.5 Identification and marking. Identification and marking shall be in accordance with MIL-STD-130. Nameplates for equipment identification shall be in accordance with MIL-DTL-15024, Type A, C or H; Style III, Size 3 and MIL-DTL-18307. All parts shall be marked with part numbers and, if applicable, lot numbers. Specifications on engineering drawings shall provide for part marking and shall indicate location of marking for accessibility.

## 5. DETAILED REQUIREMENTS

5.1 Loading of stores. The BRU/store interface shall be designed with adequate space provisions to allow safe, rapid loading and off-loading of all applicable stores with a minimum of personnel, no peculiar equipment or tools required. This interface shall provide good visibility and easy access to all controls, connections, switches and devices that relate to store loading/off-loading operations and positive visual determination of status of store installation. Consideration shall be given to store handling equipment installation (including manual loading equipment) and vertical support/lug entry angle during loading/off-loading operations. BRU geometry shall provide for the proper application of existing non-permanent hoisting adapters, hoisting devices including manual loading equipment, and loading carts or trucks as specified herein. All loading

and off-loading or related equipment attachment or installation points shall be clearly marked and identified as to proper usage. For Navy aircraft applications, any BRU loading attachments or hoisting components shall be capable of withstanding a vertical limit loading of + 2.67 g and carrier roll rates of  $\pm 20^\circ$  per second with a 17 second period and pitch of  $\pm 3^\circ$  with an 8 second period. BRU/store interface shall be compatible with the controls, load application range, and operational requirements of current applicable U.S. inventory support equipment including Single Hoist Ordnance Loading System (SHOLS) (see MIL-I-8671). In addition, for all DoD Services the interface shall provide compatibility with manual loading equipment such that stores up to and including the 1,000 pound class can be loaded rapidly and safely with a minimum of personnel and without special tools or equipment. All connections or disconnections, i.e., arming wire installation, cartridge installation, fuzing connections, and safety interlock function required during this sequence of events, shall be accomplished after the store is structurally attached to the BRU without releasing the store attachment (see AIR STD 20/17).

5.1.1 Support Equipment (SE). The BRU shall be designed to be installed, tested, serviced and maintained using standard support equipment and hand tools. Use of common hand tools shall be maximized. All support equipment shall be identified and grouped by maintenance level (organizational and intermediate).

5.1.2 Store vertical support. The BRU vertical support system shall consist of 14-inch or 30-inch vertical supports to accommodate stores up to 5000 lbs for two-piston BRUs (U.S. Air Force and U.S. Navy), or up to 2000 lbs for single-piston BRUs (U.S. Army), through the interfaces specified in MIL-STD-8591. The vertical supports shall be located as shown on Figures 1 and 2 for two-piston BRUs and Figure 3 for single-piston BRUs. BRU lower surface to store upper surface clearance shall be as specified in MIL-STD-8591 (STANAG 3575 and AIR STD 20/10).

5.1.2.1 Vertical support latching. Latch mechanisms shall be used to secure the vertical supports in their captive positions. The engagement of the vertical support latches shall be automatic as the store suspension lugs engage the vertical supports, and each latch shall independently engage its vertical support as the store is loaded onto the BRU. The latch mechanism design shall incorporate a latch drive that will force the latch mechanism from its LATCHED to UNLATCHED positions. The latch drive shall operate as part of the normal aircraft release operation or be manually driven during loading or downloading of stores. Latches shall dependently and simultaneously disengage all vertical support during store release operations. After store release, the vertical supports and latch mechanisms shall automatically engage and latch during the next store loading operations without additional actions of the loading crew. Vertical supports and latches shall be designed so that they will not latch unless the vertical supports are properly placed in their captive positions. The BRU vertical supports and their latching mechanisms shall be designed such that the vertical supports are either latched or unlatched and cannot be placed in an in-between state where the vertical supports are partially latched. The latch mechanism shall provide a positive indication of its latched or unlatched state and shall not be capable of providing a false latched indication. The latch state indicator shall be

MIL-STD-2088B

visually discernible on both sides of the BRU without requiring power. The latch and latch drive shall be designed to operate with the functions of the safety interlock and its drive mechanism. The latch mechanism design shall not be susceptible to inadvertent release due to the failure of a single component. Vertical supports and their latching mechanisms shall be designed to be functionally insensitive to manufacturing and assembly tolerances, wear, normal misuse during handling, aircraft induced loads and vibration, and contamination build-up on their surfaces. The force required to latch each vertical support and engage its latching mechanism shall be not greater than 25 pounds per vertical support for Type I BRUs and 50 pounds per vertical support for Type II BRUs.

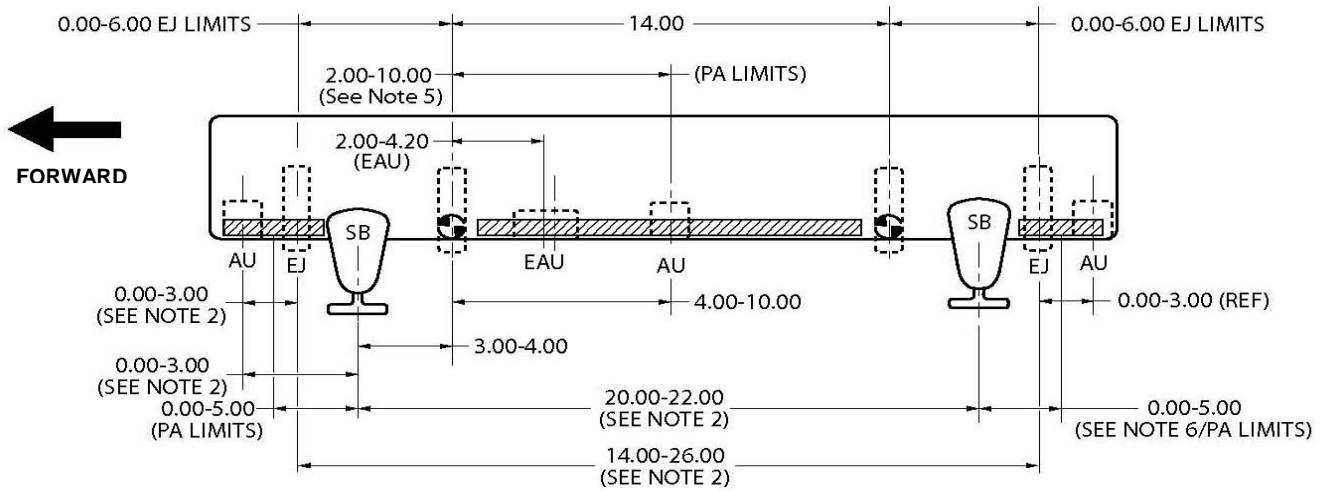

Notes:

1. Dimensions are in inches
2. Dimensions are symmetrical about the midpoint of the 14-inch hook spacing
3. Legend:
  - SB = Swaybrace
  - AU = Mechanical fuze arming unit
  - EAU = Electrical fuze arming unit (MK 39 Receptacle)
  - EJ = Ejector
  - ⊗ = Store suspension hook
  - ▨ = Positive arming attachment (PA)
4. All dimensional limit lines are located at  $\phi$  of feature
5. When an EAU is installed, one of the positive arming attachments shall be 3.00 to 4.00 inches aft of the forward 14-inch suspension hook
6. The 0.00 to 5.00 inch positive arming attachment position (PA) begins outboard of all swaybrace structure

FIGURE 1. 14-inch vertical support spacing Type I, two-piston bomb rack unit (BRU) geometric relationships.

MIL-STD-2088B

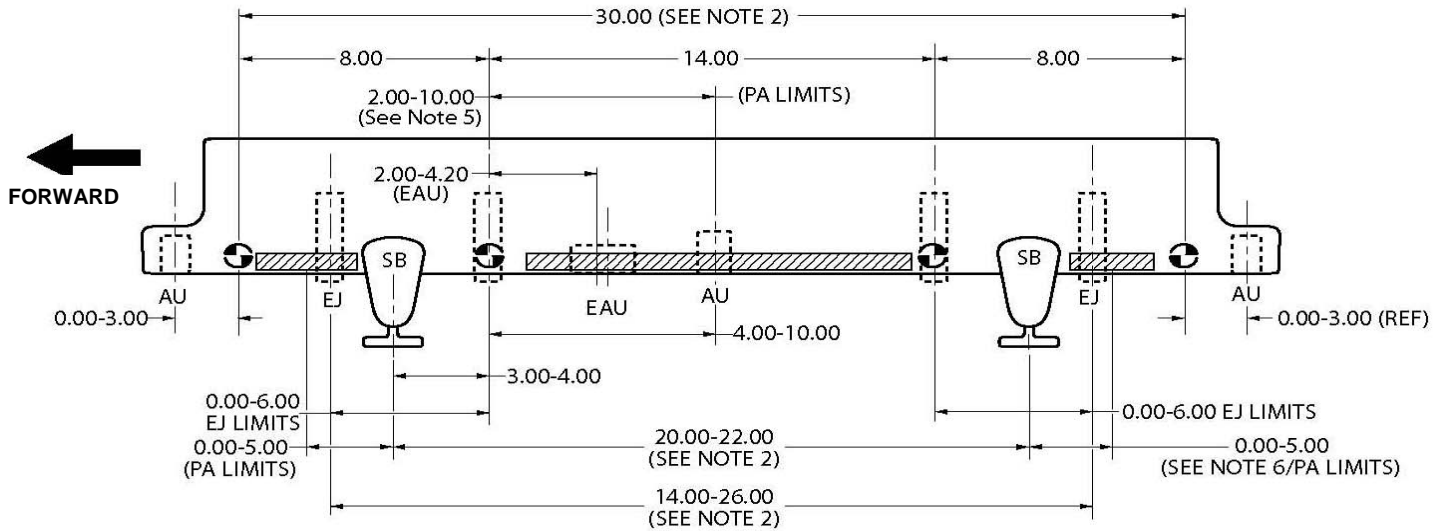

Notes:

1. Dimensions are in inches
2. Dimensions are symmetrical about the midpoint of the 14-inch hook spacing
3. Legend:
  - SB = Swaybrace
  - AU = Mechanical fuze arming unit
  - EAU = Electrical fuze arming unit (MK 39 Receptacle)
  - EJ = Ejector
  - ☉ = Store suspension hook
  - ▨ = Positive arming attachment (PA)
4. All dimensional limit lines are located at  $\phi$  of feature
5. When an EAU is installed, one of the positive arming attachments shall be 3.00 to 4.00 inches aft of the forward 14-inch suspension hook
6. The 0.00 to 5.00 inch positive arming attachment position (PA) begins outboard of all swaybrace structure

FIGURE 2. 14/30-inch vertical support spacing Type II, two-piston bomb rack unit (BRU) geometric relationships.

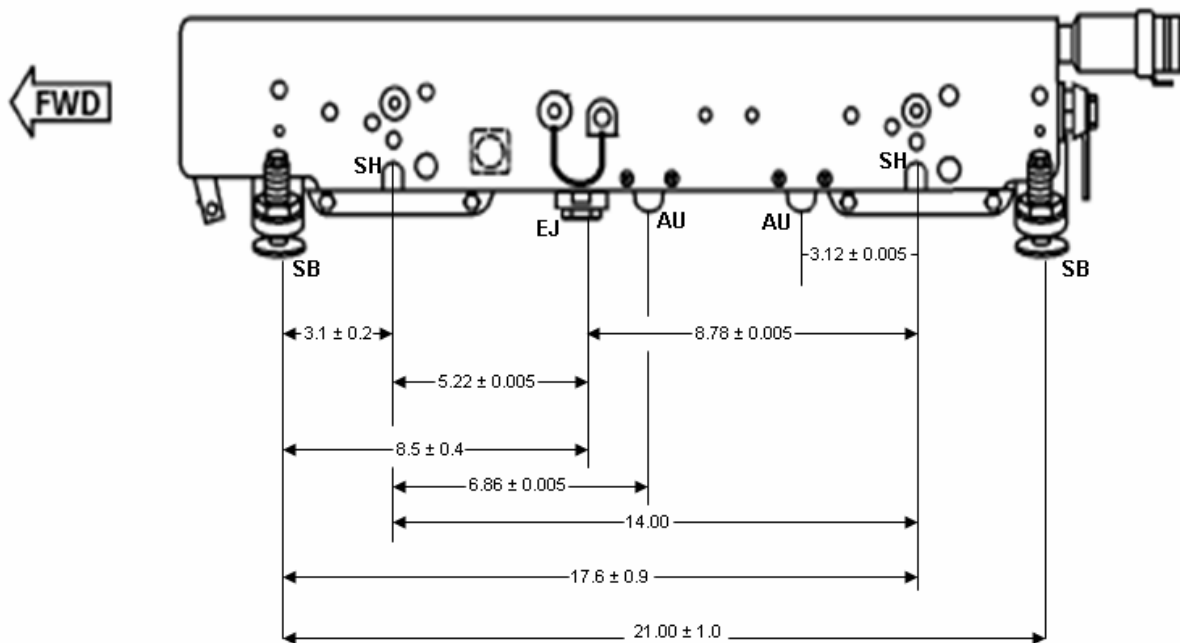

Notes:

1. Dimensions are in inches.

2. Legend:

SB = Swaybrace

AU = Mechanical fuze arming unit

EJ = Ejector

SH = Shore suspension hook

3. All dimensional limit lines are located at  $\frac{1}{2}$  of feature.

FIGURE 3. 14-inch vertical support spacing Type I, single-piston bomb rack unit (BRU) geometric relationships.

5.1.2.2 Vertical support latching security. The vertical support latch mechanisms shall be designed to prevent the inadvertent release of a store under any of its operational environments. Adequate margin to prevent unlatching shall be determined based on the resultant forces acting on the vertical support latch mechanism assuming worst case dynamic load conditions and using the worst case design physical dimensions.

a. Worst case dynamic load conditions shall consider aircraft dynamic flight environments, swaybrace performance, harmonic oscillation of the latch drive linkage, and potential load transients.

b. Worst case design physical dimensions shall include the worst case assumptions of machining tolerances, adjustment and alignment capabilities, life time material wear, and potential aircraft environment contamination build-up.

5.1.3 Store sensing. The BRU shall provide remote indication of store presence status (store present signal), which is not susceptible to a single point failure providing an incorrect status. The sensing device shall provide a logic signal to the control system identifying store presence status. Store sensing shall ensure that a hung store retained by only one vertical support is sensed as a store present.

5.1.3.1 Store sensing failure mode. Mechanical or electrical failure of the store sensing device shall be in the fail-safe mode (store not present).

5.1.4 Fuzing and arming control. The BRU design shall include integral, mechanical, and electrical fuze Arming Units (AUs) to control the "SAFE/ARM" function of fuzes on appropriate conventional stores. The BRU shall be capable of independent operation of each AU. All arming wire-to-AU connection points shall be easily accessible with the store fully latched and restrained. All locations shall be as specified in 5.1.4.1 and 5.1.4.2, and interface connections shall comply with MIL-STD-8591. Additionally, the BRU design shall include positive arming attachment points as specified in 5.1.4.3.

5.1.4.1 Mechanical fuze AUs. The BRU shall provide up to three continuous duty electromechanical AUs to control the store mechanical fuze(s) "SAFE/ARM" functions. The AUs shall be mechanically linked to the BRU (AIR STD 20/17) latching mechanism with provisions for the following:

- a. An energized AU shall retain an arming wire with a minimum force of 600 pounds.
- b. With vertical latching mechanism closed, shall retain arming wire to preclude preload problems during captive carriage (AU not energized and BRU vertical supports closed).
- c. Shall allow zero retention force on arming wire when store is released and AUs are "safe" or not energized.

## MIL-STD-2088B

- d. AU locations shall permit easy insertion and removal of standard arming wire swivel and ring assemblies, NAVAIR drawing 923AS190, with the store restrained.
- e. Shall not be susceptible to inadvertent operation due to shock, vibration, or store ejection per MIL-T-7743.
- f. Shall retain arming wire loops after an “armed” drop, even after the BRU is de-energized, until arming wire loops are manually removed.
- g. The AU shall be located on the BRU lower longitudinal centerline.
- h. The centerline of the AU arming loop retaining mechanism shall be positioned such that it allows for the installation and removal of arming loop with store present.
- i. The mechanical fuze AUs shall be located as shown on Figures 1, 2, and 3.
- j. Each AU shall operate reliably at a nominal 28 volts direct current (VDC), at a maximum of 250 milliamperes per MIL-STD-704 normal operation voltage range.
- k. A temporary voltage surge, up to  $\pm 45$  VDC maximum, across the arming unit power input terminals shall not damage the AU’s ability to operate properly and shall conform to the requirements of 5.1.9.2.

5.1.4.2 Electrical fuze AU. Electrical fuzing is a Department of Defense unique item. When required by the procuring activity, the BRU shall provide an electrical fuze AU as specified in MIL-C-81842 at the location as shown on Figure 1 and Figure 2 to ensure compatible electrical fuze functioning with the MK 122 arming safety switch as specified in NAVAIR WS-2081. There shall be an interlock function provided between the BRU release linkage and fuze charging line, whereby the electrical AU senses correct linkage movement representing properly intended store release, before the electrical pulse shall be permitted to enter the electrical fuze connector. The electrical fuze arming circuit shall be such that the predominant failure mode of the electrical fuzing shall be in the fail-safe mode (not fuzed). The fuze circuit shall be designed such that a hung store by either vertical support shall not arm/fuze the device. Adjacent to the electrical arming unit shall be a positive arming attachment (see 5.1.4.3) compatible with the MK 122 arming safety switch. Vertical access and clearance shall be provided to permit MK 122 arming safety switch connection to the electrical AU by hand with the store latched and restrained.

5.1.4.3 Positive arming attachment. Unless otherwise specified by the procuring activity, a minimum of four positive arming attachments shall be provided. They may be located on both sides, or one side, of the BRU along its entire length (longitudinal axis) as shown on Figures 1 and 2. The location of the positive arming attachments with installed arming wires shall not

MIL-STD-2088B

interfere with BRU functions such as the operation of the mechanical fuze AUs, ejector pistons, and swaybraces. The procuring activity shall determine the maximum number of positive arming attachments. The positive arming attachment spring latch assembly shall be as specified on NAVSEA drawing 2263759, or an equivalent hard point shall be provided. The axis of the latch shall be located approximately 1 inch above the uppermost surface of the store body and attached to the side of the BRU. The positive arming attachments shall be positioned in a manner to preclude opening in flight from aerodynamic loading. If the BRU is required by the procuring activity to provide an electrical fuze AU (see 5.1.4.2) then one positive arming attachment shall be positioned at the location specified in Note 5 of Figures 1 and 2.

5.1.5 Swaybraces. Automatic, semi-automatic, or rapid activating BRU swaybraces shall be provided for all stores after independent activation of both vertical supports supporting the store. Swaybraces shall be located symmetrically about vertical supports as shown on Figures 1 and 2 and laterally within the reinforcement area of MIL-STD-8591 (STANAG 3575 AA and AIR STD 20/10). The swaybraces shall be capable of reacting the design loads without the use of adapters. For standardization purposes, as a minimum, the swaybraces and related BRU systems shall accommodate store diameter as follows:

<u>SUSPENSION</u>	<u>DIAMETER</u>
14-inch	8.0 to 20.0-inch
14/30-inch	8.0 to 20.0-inch for 14-inch 8.0 to 30.0-inch for 30-inch

Swaybraces shall be designed so that they cannot apply excessive loads to the store or BRU to prevent store release. After all swaybraces have been activated, the store shall be held securely in all three axes until separation of the store. The application of the swaybraces at any point shall have a centering action on the store that tends to keep the store symmetric about the BRU vertical axis. The contact of the swaybraces to the store shall exhibit at least line contact on a store conforming to MIL-STD-8591. The swaybraces shall not require any scheduled maintenance nor be susceptible to damage by sand, dust, or supersonic airflow impingement. The swaybraces shall be capable of interfacing with stores having reinforced areas as specified in MIL-STD-8591.

5.1.6 Safety interlock. The BRU shall contain a safety interlock mechanism that interrupts both the BRU’s electrical initiation control circuit and its mechanical store support latch release operation (STANAG 3575 AA and AIR STD 20/10). Each of the two interrupts shall be removed as a result of separate and distinct events as detailed in the following paragraphs.

5.1.6.1 Safety interlock status. The safety interlock mechanism shall have a minimum of two distinct position settings: SAFE and ARMED. If the BRU requires ground operation with stored energy present, then a third position, GROUND, may be required. With both the electrical and mechanical interrupts in place, the safety interlock shall be in its SAFE position.

With both the electrical and mechanical interrupts removed, the safety interlock shall be in its ARMED position. With the electrical interrupt in place and the mechanical interrupt removed, the safety interlock shall be in its GROUND position. The BRU shall provide both local and remote status indication of the safety interlock mechanism. Local status indication shall provide visual indication of the safety interlock mechanism's position. The position indicator shall be mechanically linked to the safety interlock and be visible from a distance of 15 feet (line of sight permitting) during daylight hours. The safety interlock shall only be capable of being set to the SAFE position with both store supports fully latched. The BRU shall provide discrete signals to remotely indicate the status of the safety interlock to the aircraft or aircraft systems monitoring equipment. The safety interlock status shall be sensed such that no single sensor failure shall provide the aircraft with an erroneous SAFE status.

5.1.6.2 Interrupt removal. During ground operations or during aircraft in-flight preparations for store release, the first event shall remove the electrical interrupt, and the second event shall remove the mechanical interrupt from the BRU allowing store support latch release operation. The first event shall not be permitted to occur unless the mechanical interrupt is in place. If sufficient energy is present on the electrical control circuit when the electrical interrupt is removed, initiation of the BRU store release may occur. If store release is initiated while the mechanical interrupt is still in place, a "Lock-Shut-Firing" of the BRU shall result. The mechanical interrupt shall be designed so that it cannot be removed by manual or automated means while the BRU is in the "Lock-Shut-Fire" state. The second event shall not be permitted to occur until time has elapsed, with the electrical interrupt removed, to permit a BRU "Lock-Shut-Firing" if release energy is present.

5.1.6.3 Alternative interrupt removal. As an alternative, the release control circuit may be monitored for the presence of electrical energy to initiate the release of the BRU's stored energy. If insufficient electrical energy is present to cause the release of energy, then the electrical and mechanical interrupts may be removed simultaneously. To ensure the accuracy and integrity of the voltage monitoring system, it shall be verified against other electrical circuit energy levels that are independently verified.

5.1.6.4 Safety interlock ground operation. During ground loading and unloading operations, the safety interlock mechanical interrupt shall be removed without the removal of the electrical interrupt. To ensure maximum protection with the mechanical interrupt removed while the electrical interrupt is in place, the electrical interrupt shall be prevented from being removed until the mechanical interrupt is replaced (SAFE position).

5.1.6.5 Safety interlock control. The safety interlock shall be designed for either manual or remote operation. Remote operation shall be controlled through the safety interlock drive mechanism using aircraft power and commands. The safety interlock mechanism shall be capable of being latched in the GROUND position for store loading or downloading operations. The safety interlock shall not be latched in the ARMED position and shall return to its SAFE position when power is removed from the drive mechanism (provided the store supports are in

their latched positions). The safety interlock shall return to its SAFE position when the GROUND position latch is released, without the use of tools. The safety interlock design shall prevent it from being forced from its SAFE position by combinations of vibration and/or acceleration forces induced by the aircraft's mission profile. The safety interlock may be held in the ARMED position by the safety interlock drive mechanism, but shall not be independently latched in the ARMED position. The safety interlock shall be operable by one person locally without power or tools and shall be capable of operation within 10 seconds. Placing the safety interlock in the ARMED position shall not release the store support latches nor provide release initiation power. The design shall not require the use of manually inserted or removable parts to accomplish safety interlock operations. The complete safety interlock system shall be protected from inadvertent operation due to external physical contact. To the maximum extent possible, the safety interlock mechanical and electrical interrupts shall be positioned within the BRU to prevent inadvertent store release as a result of single component failures. There shall only be one safety interlock mechanism for each BRU.

5.1.6.6 Safety interlock drive mechanism. The BRU shall have an in-flight operable drive mechanism for its safety interlock. This drive mechanism shall require the application of energy to force the safety interlock from its SAFE position to its ARMED position. When in its de-energized state, the drive mechanism shall not force the safety interlock from its SAFE position during any combination of vibration and/or acceleration forces induced by the aircraft's mission profile. When commanded by the aircraft, energy shall be applied to the drive mechanism. The drive mechanism shall place the safety interlock in its ARMED position as a result of either the two separate and distinct events as required by "interrupt removal" or as a single event in accordance with the requirements of "alternative interrupt removal." Control power for the drive mechanism shall be derived from normal aircraft power. The drive mechanism shall be designed to allow the safety interlock to return to its SAFE state when either the intent to release the store is no longer present or the BRU power is removed.

5.1.6.7 Safety interlock override system. If required by the procuring activity, a means shall be provided to override all mechanical and electrical store support latching safety interlocks. This override system shall be utilized if the BRU fails to drive the safety interlock to its ARMED position when commanded as part of a normal store release. The safety interlock override system design shall meet all requirements for emergency jettison regardless of safety interlock status. (NOTE: Emergency jettison action shall require the simultaneous release of all store support latches in less than 0.50 second.) The override of the safety interlock shall simultaneously remove the electrical and mechanical interrupts of the BRU safety interlock mechanism. The operation of the override shall not release the store. The override shall have the capability of remote indication of status and operation. Power for the override system's operation shall come from a source that is separated from and independently controlled from that of the BRU safety interlock. The override system design and functional requirements shall consider and be compatible with all operational modes and environments consistent with the aircraft mission requirements.

5.1.6.8 Additional release operation interrupts. If any additional release interrupt devices are required, they shall not defeat the functions of the safety interlock mechanism (i.e. the removal of any additional interrupt while the safety interlock is in the ARMED state shall not result in an inadvertent release operation of the BRU). Additional interrupt designs shall consider any single point safety requirements.

5.1.7 Store release and ejection system. Primary store ejection release shall occur at all aircraft attitudes within the release envelope with all store restraining mechanisms removed simultaneously and the vertical supports driven to the release position by compatible sequencing of the release and store ejection mechanisms (STANAG 3575 and AIR STD 20/10). The store ejection velocity, release attitude, and resultant reaction forces shall be applied through the ejector system except in its gravity release mode, or the BRU may be designed as a gravity release device only. Both ejector BRUs and gravity release BRUs may be actuated/powered by impulse cartridges, pneumatic pressure or hydraulic pressure. Electrical power shall be used to ignite the cartridges, or electrical power shall be used to operate solenoids to activate pneumatic or hydraulic pressure. A gravity release BRU may also be actuated/powered by other means that directly drives its vertical supports to the release position.

5.1.7.1 Gravity release BRUs. For gravity release BRUs, requirements for ejection force, reaction loads, separation velocity, and ejector pistons do not apply. All other requirements shall apply.

5.1.7.2 Pyrotechnic actuated BRUs. If cartridge(s) are used, the release and ejection system shall be initiated remotely by independent aircraft electrical sources (primary and secondary). Independent initiation circuits shall follow separate wiring to the cartridges. The BRU shall allow for the simultaneous initiation of both impulse cartridges from either electrical source as detailed in Figure 4. The BRU shall provide for the sympathetic ignition (ignition of one cartridge shall ignite the other) of either impulse cartridge by the other without sacrificing ejector performance.

5.1.7.2.1 Cartridges. If cartridges are employed in the ejector system, the cartridges and ejector system shall be designed, but not limited, to the following requirements:

- a. Two cartridges shall be utilized as a minimum.
- b. The ejector system shall be actuated by the initiation of any combination of cartridges as specified by the procuring activity.
- c. Cartridge interface and utilization shall comply with MIL-D-81303. (Cartridge geometry is specified in MIL-D-81303.)
- d. Cartridge power sources shall provide a minimum of 3 amperes at 28 VDC and meet the requirements in MIL-STD-704, for normal and emergency operation. Each power source shall

use an independent driver for each of the two cartridges (see Figure 4). These drivers, when not activated, shall be capable of withstanding the transient voltages generated when the cartridge bridge wires burn open due to activation by the primary or secondary power source.

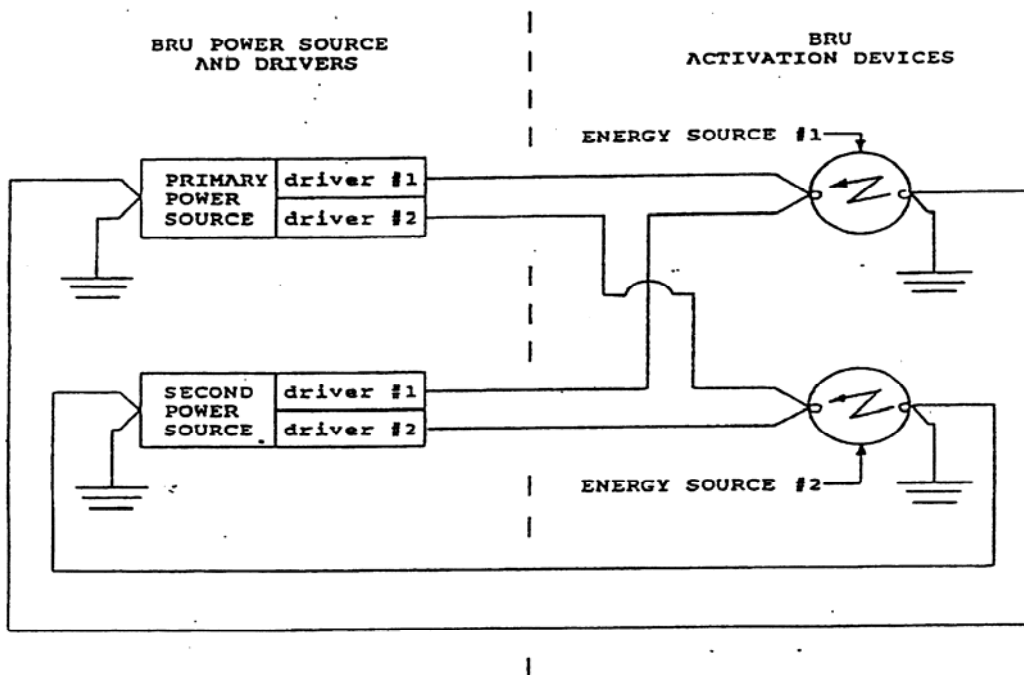

FIGURE 4. Wiring schematic to achieve primary and secondary release.

5.1.7.2.2 Cartridge firing pin. The cartridge firing pin configuration and characteristics shall be as follows:

- a. Shank diameter of  $0.092 \pm 0.002$  inch.
- b. Point of  $90^\circ$  included angle with 0.005 inch diameter maximum flat.
- c. Hardness, Rockwell 59 to 62 HRC.

5.1.7.2.3 Cartridge breech. The diameter of the cartridge breech (or cartridge holder if used) shall be a straight bore of  $1.081 + 0.003 - 0.000$  inches over its full length. Any taper existing within these limits shall be uniform over the full length of the breech or cartridge holder, with the maximum diameter occurring at the end adjacent to the cartridge flange. The surface finish on the cartridge breech shall be a minimum of 32 microinches, root mean square (rms). Cartridge breech design shall provide cartridge firing pressure in the range of 3,000 to 25,000 PSI, with confinement of the cartridge main charge propellant for reproducible performance. The breech or cartridge holder shall be designed to permit "end burst" of the cartridge such that

## MIL-STD-2088B

all generated hot gases exit the cartridge through its closure disc and not the aluminum cartridge case. Means shall be provided at the end of the ejector piston cycle to safely vent the remaining gas pressure. To comply with a 0.008 man-hour (30-man second) cartridge removal and installation time for all cartridges of the BRU, provisions shall be made for quick installation of cartridges, rapid cap insertion and positive integral extraction of expended cartridges to facilitate unaided manual cartridge removal. System design shall provide for:

- a. Internal cleaning without removal of BRU from the aircraft and without the use of special support equipment.
- b. Breech removal and installation, for cleaning, at the organizational level, shall require a minimum of effort.
- c. A means other than removal of components or movement of electrical connections to indicate cartridge installation.
- d. A means other than removal to indicate an expended cartridge.
- e. Breech cleaning shall be required only after 50 ejections or 30 days, whichever occurs first (see 4.3.11.4.1.1).
- f. Firing pin to breech cartridge bore true positioning of 0.015 inch diameter.
- g. Full support of cartridge base upon installation and during firing.
- h. Allowing for repeated installations, firing pin/cartridge electrode contact design shall maintain a force ranging from 40 pounds-force (lbf) to 100 lbf.
- i. Preclude shorting to ground of electrode upon cartridge installation.

5.1.7.3 Pneumatic/hydraulic activated BRUs. A pneumatic/hydraulic activated BRU shall be powered by the pneumatic or hydraulic pressure stored in a pressure vessel. Various pressure vessel design configurations can be provided:

- a. Integral or external to the BRU.
- b. Removable or fixed.
- c. Rechargeable on ground (by replacement or direct charge) or in flight (through dedicated on-board pressure generation).

Whichever design is selected for the pressure vessel configuration, the vessel and ejector system shall be designed, but not limited, to the following requirements:

## MIL-STD-2088B

a. An automatic seal (e.g. check valve) shall maintain vessel pressure if the aircraft-supplied pressure source is removed. An automatic or manually operated seal shall maintain pressure if the ground supplied pressure source is removed.

b. A mechanical method to prevent over-pressurization of the pressure vessel shall be provided. Examples are a mechanical relief valve or a burst disc.

c. The release and ejection system shall be initiated remotely by independent aircraft electrical power sources (primary and secondary). Independent initiation circuits shall follow separate wirings to activate redundant energy source control devices. Examples are the use of two solenoids for the same function or a solenoid with dual coils, with each coil wired independently to the aircraft (see Figure 5). Ejection performance shall not be affected by the loss of either primary or secondary aircraft electrical power source.

d. In order to enable the aircraft release control system to initiate release with sufficient pressure to achieve safe store separation, the BRU shall provide pressure vessel status. An example is a pressure transducer integral to the BRU that supplies a signal to the aircraft's stores management system.

e. A method to bleed all stored pneumatic or hydraulic pressure from the BRU. This device shall be manually operated, but the use of common hand tools normally available on the flight line is acceptable.

f. After store release or ejection, all downstream pressure from the pressure vessel shall vent.

g. The release control device operation shall be designed to ensure that once the store release process has been initiated it shall not be possible to interrupt it until safe store separation has been achieved.

h. The BRU in conjunction with its safety interlock shall provide a method to safely load and unload stores with its pressure vessel charged.

i. For pneumatic BRUs, the gas used for pressure vessel filling shall be industrial nitrogen, (A-A-59503, type I, grade B) or air containing less than 15 ppm of water containing no solid particles over 5  $\mu\text{m}$  in length. If the BRU pneumatic supply source cannot meet the 15 ppm requirement for water contamination, then its design shall account for the effects of stress corrosion in high pressure vessels due to water condensation.

j. For hydraulic BRUs, the fluid used for pressure vessel filling shall be specified by the procuring activity.

- k. Allowable leakage rate of the pressure vessel shall be specified by the procuring activity.
- l. Any leakage shall not result in pressurization downstream of the pressure vessel.

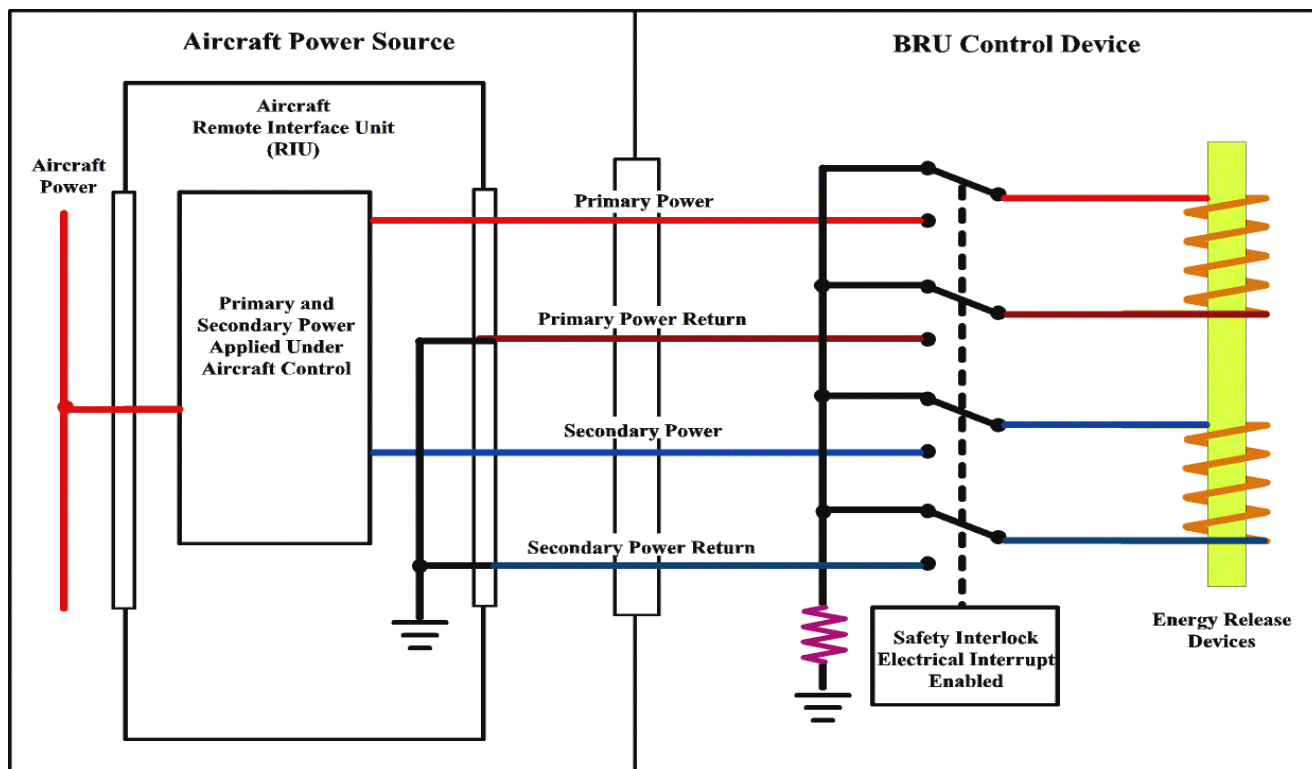

FIGURE 5. Initiation circuits to activate redundant energy source control devices.

5.1.7.3.1 Pneumatic interface. The pressure vessel charging connection shall be located to enable replenishment when the vessel is installed on the pylon/BRU or aircraft, and shall be compatible with ground support equipment as specified by the procuring activity.

5.1.7.3.2 Pneumatic activated BRUs with removable energy source. A pneumatic activated BRU may be powered by a removable energy source. This vessel may directly interface to the BRU or may be at a remote location in the aircraft and interface to the BRU through appropriate plumbing.

5.1.7.4 Ejection force. Ejection force shall be applied to a store in such a manner as to provide adequate store velocity, pitch attitude, and pitch rate to ensure safe store separation from the aircraft. Unless otherwise specified by the procuring activity, the maximum ejection force applied to a store by the BRU shall be not greater than 22,500 pounds. If multiple ejector pistons are used, the maximum ejection force shall be distributed between the pistons to achieve the desired pitch control. The pressure applied on a store shall be not greater than 15,000 psi. If

ejecting stores with greater force than identified herein, the facilities shall exist in the BRU to reliably reduce the performance to the identified limits. Ejection reaction forces shall be compatible with BRU mounting and aircraft station capabilities. Store ejection force application shall be as shown on Figures 1, 2 and 3. Application of ejection forces shall not induce impact loading that will damage the BRU or store.

5.1.7.5 Separation parameters. The procuring activity shall specify for any store mass the minimum required separation velocity of the store center-of-gravity and the pitch rate at the end of the ejector stroke.

5.1.7.6 Ejector pistons. Upon loading, the ejector pistons shall automatically contact and pre-load against the top surface of the store. After store ejection, the ejector pistons shall automatically retract.

5.1.8 Safety in design. An active safety program shall be implemented and specific requirements introduced into the BRU design and development.

5.1.8.1 BRU safety program. Safety shall be achieved through pre-engineering safety analyses and evaluation of design concepts. This effort shall provide surveillance, control, and visibility to ensure that no design creates a condition that can cause personnel injury, damage, or loss of equipment. The safety program shall meet the objectives to:

a. Eliminate all MIL-STD-882 Categories I and II hazard levels and provide control of all Category III hazard levels commensurate with mission objectives. To select an optional corrective action and to determine whether to implement the corrective action, a tradeoff study shall be conducted. Final implementation shall be acceptable to the procuring activity.

b. Ensure the subassemblies or components cannot be incorrectly assembled or incorrectly installed.

5.1.8.1.1 Safety program functions. The safety program shall contain the following MIL-STD-882 requirements, as a minimum:

a. Provide for qualitative systems analyses to identify potential hazards. Close attention shall be given to those design features and characteristics that have created safety related problems on previous systems.

b. Submit periodic safety program status reports identifying all category hazard levels, including probability of occurrence. Probabilities shall be based on mean time between failures (MTBF) data and past failure histories. If a corrective safety program has been identified and is to be corrected within the scope of the contract, the corrective action also shall be included.

c. The safety program personnel shall participate in all design reviews as part of the overall safety effort.

5.1.8.1.2 Failure modes, effects and criticality analysis. During the BRU development process, the BRU shall be analyzed for possible failure modes resulting from anticipated environmental and load conditions. This analysis shall evaluate the likelihood of occurrence of identified failure modes. For each failure mode identified, a determination shall be made of the effect of the part, circuit, or unit in question and of the ultimate significance of this effect relative to overall system safety. This analysis shall include a discussion of the factors inherent in the design or the quality program that shall minimize the likelihood of occurrence of those failures having the most significant effect on system safety. This analysis shall be updated as design configuration and load conditions change and shall be reviewed by the procuring activity.

5.1.8.1.3 Inadvertent release. Inadvertent release or arming of a store shall not occur due to the failure or malfunction of one single component of the BRU.

5.1.8.1.4 Locked shut functioning. In a locked shut functioning of the BRU, energy dissipation shall not be accomplished in any manner which could lead to personnel hazard, structural damage, or both. The lock shut firing shall not cause store release, hazard to personnel, system structural damage, or unscheduled maintenance.

5.1.8.1.5 Driven items. Except for the ejector pistons, no driven items shall be externally exposed.

5.1.8.1.6 Impulse cartridges. Impulse cartridge venting into the following areas shall be unacceptable:

a. Area where direct exposure of personnel to hot gas exhaust performing normal duties would occur.

b. Internally in any vicinity where venting would cause degradation of the BRU such as the electrical wiring and mechanical equipment.

5.1.8.1.7 Pneumatic or hydraulic BRU safety requirements. Failure of the vessel pressure sensing device shall be in the fail-safe mode (insufficient pressure present). High pressure failure of the vessel shall not result in ballistic fragmentation unless the vessel is encased so as not to pose hazard to personnel or aircraft. For inspection and servicing, the BRU shall be equipped with a means of relieving any residual pressure from the pneumatic circuit, both upstream and downstream of the release control device(s). Other than potentially requiring the use of hearing protection, venting of the BRU pneumatic circuit shall not be a hazard for ground personnel, nor physically damage or functionally affect the surrounding structure and equipment. If a removable pressure vessel is used, the following safety aspects shall be addressed: The physical connection to or removal of a pressure vessel from the BRU pneumatic circuit,

irrespective of its charge level, shall not represent a hazard for ground personnel and shall not physically damage or affect the functionality of surrounding structure and equipment. A built-in safety feature shall exist to prevent the actuation of the pneumatic connection before the reservoir is safely restrained. The physical removal of the reservoir shall not produce unintended venting or recoil action. If, in order to obtain a safe disconnect, venting is needed at either side of the pneumatic interface, then a built-in safety feature shall exist to prevent the disconnection until either side is safely vented. Should the BRU inadvertently “fire” during loading and unloading of stores with its pressure vessel charged, all driven items, such as ejectors, shall be precluded from injuring ground personnel or damaging equipment or the aircraft.

5.1.9 Electromagnetic environmental effects (E<sup>3</sup>). The control of E<sup>3</sup> shall be as specified in 5.1.9.1 through 5.1.9.9.

5.1.9.1 Electromagnetic compatibility (EMC) program. A system EMC program in accordance with the requirements of MIL-STD-464 shall be applied. This program shall be supported by an Electromagnetic Compatibility Advisory Board (EMCAB) established in accordance with the requirements of NAVAIR AR-43. The specifics for the EMC program effort are provided in the Electromagnetic Compatibility Program Plan (EMCPP).

5.1.9.2 Electromagnetic interference (EMI). The BRU electrical system shall meet the requirements of MIL-STD-461 Class A1b and MIL-STD-464. For U.S. Army Aviation, the requirements of ADS-37A-PRF, Table 1, parts A and B shall be met.

5.1.9.2.1 Electromagnetic pulse (EMP). The BRU shall meet the EMP requirements of MIL-STD-464.

5.1.9.3 Electromagnetic vulnerability (EMV). The BRU electrical system shall meet the EMV requirements of MIL-STD-464. For U.S. Army applications the system shall also meet the requirements of ADS-37A-PRF.

5.1.9.4 Lightning protection. The BRU system shall meet the requirements of the EMC program to provide compliance with the requirements of MIL-STD-464 for protection against lightning.

5.1.9.5 Bonding and grounding. The BRU system shall meet the requirements of the EMC program to provide compliance with the requirements of MIL-STD-464.

5.1.9.6 Wiring and cabling. The BRU shall meet the requirements of the EMC program to provide compliance with the requirements of SAE-AS50881.

5.1.9.7 Static electricity. The BRU system shall meet the requirements of the EMC program to provide compliance with the requirements of MIL-STD-464 for static electricity effects.

5.1.9.8 Hazards of electromagnetic radiation to ordnance (HERO). As required by the statement of work or the purchase specification, the BRU system shall meet the HERO requirements of MIL-STD-464 (STANAG 3575 AA).

5.1.9.9 Coupling factor (CF). The BRU shall be considered a potential coupling device which may provide entry for excessive Radio Frequency (RF) energy from the external environment, through the BRU into the remainder of the weapon system and possibly the entire aircraft system. The BRU shall utilize shielding, filtering or such other EMI suppression techniques as may be required to ensure that the external electromagnetic (EM) environment shall not be coupled through the BRU. The external EM environment shall be specified in MIL-STD-464.

## 5.2 Electrical requirements.

5.2.1 General. The BRU shall conform to the following electrical requirements stated herein. Additionally, all signals shall conform to the E<sup>3</sup> requirements of 5.1.9. The BRU designer shall utilize all or a subset of the signals in the paragraphs listed.

5.2.2 BRU structural ground. The BRU shall provide a conductive path from metallic parts of its outer skin to the BRU support structural interface.

5.2.3 Nose arm. This aircraft signal is the primary signal to the arming unit solenoid located in the front of the BRU. Activation of this signal shall cause the forward arming solenoid to activate and retain the forward mechanical arming wire upon store release. This function shall operate from a nominal 28 VDC/open discrete as specified in MIL-STD-704, normal operation voltage range, and shall not require greater than 0.250 ampere on a continuous basis.

5.2.4 Center arm. If required, this aircraft signal is the primary signal to the arming unit solenoid located in the center of the BRU. Activation of this signal shall cause the center arming solenoid to activate and retain the center mechanical arming wire upon store release. This function shall operate from a nominal 28 VDC/open discrete as specified in MIL-STD-704, normal operation voltage range, and shall not require greater than 0.250 ampere on a continuous basis.

5.2.5 Tail arm. This aircraft signal is the primary signal to the arming unit solenoid located in the rear of the BRU. Activation of this signal shall cause the aft arming solenoid to activate and retain the aft mechanical arming wire upon store release. This function shall operate from a nominal 28 VDC/open discrete as specified in MIL-STD-704, normal operation voltage range, and shall not require greater than 250 milliamperes on a continuous basis.

## MIL-STD-2088B

5.2.6 Electrical fuzing. As required by the procuring activity, this aircraft signal, when present upon store release shall be transmitted directly to the store. After both vertical supports open, connection shall be made to arm the store. The devices used to transfer these voltages (+ 195 VDC, + 300 VDC) shall be capable of closing and carrying a momentary current of one ampere.

5.2.7 Primary release command. This electrical signal, 28 VDC, to the BRU shall be the primary initiator of the release of the store. Energy sources for opening the BRU vertical supports may include pyrotechnic, pneumatic, hydraulic, or solenoid.

5.2.7.1 Impulse cartridge. When impulse cartridges, as specified in 5.1.7.2.1 b, are used as the release and ejection energy source, this signal shall cause initiation of the primary store release cartridge in the BRU, resulting in the opening of the vertical supports, and extension of the ejector pistons. This command shall operate from a nominal 28 VDC open discrete, shall not require more than 12 amperes (at 15 °C) for more than 50 milliseconds and shall meet the requirements of MIL-STD-704, emergency operation voltage range.

5.2.7.2 Solenoid release. When solenoids are used as the release energy source, this signal shall energize the primary store release solenoid in the BRU, resulting in the opening of the vertical supports. This command shall operate from a nominal 28 VDC open discrete, shall not require more than five amperes (at 15 °C) for more than 75 milliseconds, and shall meet the requirements of MIL-STD-704, emergency operation voltage range.

5.2.8 Secondary release command. This signal to the BRU is the secondary store release initiator should a failure occur in the primary release command circuit. This signal may be applied simultaneously with the primary release command. The characteristics of the secondary release devices shall be identical to those of the primary release devices.

5.2.9 Auxiliary release command. As required by the procuring activity, this signal to the BRU shall initiate a gravity release from the BRU by release of the vertical supports. This operation shall be not greater than the requirements of a primary activation.

5.2.10 Safety interlock electrical requirements. This section describes the electrical power requirements for the control, status and power lines of the BRU safety interlock and interlock override systems.

5.2.10.1 Safety interlock mechanism status. This open/ground 28 VDC discrete shall be capable of sinking 250 milliamperes.

5.2.10.2 Safety interlock drive mechanism electrical power. This power line provides a maximum of 10 amps, 28 VDC power, and shall be in accordance with MIL-STD-704 emergency operation range.

## MIL-STD-2088B

5.2.10.3 Safety interlock override status. If used, this open/ground 28 VDC discrete shall be capable of sinking 250 milliamperes.

5.2.10.4 Cartridge actuated device (CAD) override control. If used, this discrete signal to the BRU shall be used to control the application of energy to the CAD actuated safety interlock override control. This electrical energy pulse shall be as specified in 5.1.7.2.

5.2.11 Vertical support status. This signal from the BRU shall confirm the opening of the BRU vertical supports. This discrete signal is a ground/open signal which changes state only when both fore and aft vertical supports have been opened. Nominal current sink capability of the devices used for this function shall be 250 milliamperes.

5.2.12 BRU presence status. This signal from the BRU shall indicate the presence of the BRU on the aircraft. This discrete signal is a ground signal used to confirm that the BRU is attached to the aircraft. Nominal current sink capability shall be 250 milliamperes.

5.2.13 Store sensing signal. This signal from the BRU shall indicate that a store is present on the BRU. This signal shall be a ground/open and shall be capable of sinking 250 milliamperes. Store sensing shall ensure that a store retained by one vertical support shall be sensed as a store present.

5.2.14 BRU power/master arm. This signal to the BRU shall be available to supply power to those mechanisms or devices requiring currents higher than those available for listed command functions such as higher current devices which will use the commands listed to activate a power switching device within the BRU to supply the current for the function. This function shall operate from a 28 VDC/open discrete.

## 6. NOTES

(This section contains information of a general or explanatory nature which may be helpful, but is not mandatory.)

6.1 Intended use. This standard is intended to be used in establishing general criteria for the design and development of a Bomb Rack Unit for carriage and powered ejection or gravity release of airborne stores (excluding air-to-air missiles) on 14 or 30-inch suspensions from fixed wing and rotary wing aircraft. It is not intended to be applicable to Small Diameter Bombs (SDB), practice bombs, or other miniature munitions which may be developed.

### 6.2 Subject term (key word) listing.

Cartridges  
Ejector racks  
Electrical fuze arming unit

Hydraulic ejection  
 Mechanical fuze arming unit  
 Pneumatic ejection  
 Positive arming attachment  
 Pyrotechnic ejection  
 Safety interlock  
 Store interface  
 Store release and ejection system  
 Stores suspension and release units  
 Swaybraces

6.3 International standardization agreement implementation. This standard implements the following international standardization agreements. When changes to, revision, or cancellation of this standard are proposed, the preparing activity must coordinate the action with the U.S National Point of Contact for the international standardization agreement, as identified in the ASSIST database at <http://assist.daps.dla.mil>.

TABLE II. Paragraphs containing international standardization agreements.

<u>Paragraph</u>	<u>Paragraph Title</u>	<u>International Standardization Agreement</u>
4.3.10	Environmental and service conditions	AIR STD 20/18
5.1	Loading of stores	AIR STD 20/17
5.1.2	Store vertical support	STANAG 3575 AA, AIR STD 20/10
5.1.4.1	Mechanical fuze arming units	AIR STD 20/17
5.1.5	Swaybraces	STANAG 3575 AA AIR 20/10
5.1.6	Safety interlock	STANAG 3575 AA AIR STD 20/10
5.1.7	Store release and ejection system	STANAG 3575 AA AIR STD 20/10
5.1.9.8	Hazards of Electromagnetic Radiation to Ordnance (HERO)	STANAG 3575 AA

6.4 Changes from previous issue. Marginal notations are not used in this revision to identify changes with respect to the previous issue due to the extent of the changes.

MIL-STD-2088B

CONCLUDING MATERIAL

Custodians:

Army - AV  
Navy - AS  
Air Force - 22

Preparing activity:

Navy - AS

(Project 1095-2007-001)

Review activity:

Air Force - 11

NOTE: The activities listed above were interested in this document as of the date of this document. Since organizations and responsibilities can change, you should verify the currency of the information above using the ASSIST Online database at <http://assist.daps.dla.mil>.