

NOT MEASUREMENT
SENSITIVE

MIL-PRF-131L
10 April 2022
SUPERSEDING
MIL-PRF-131K
18 August 2005

PERFORMANCE SPECIFICATION
BARRIER MATERIALS, WATERVAPORPROOF, GREASEPROOF,
FLEXIBLE, HEAT-SEALABLE

This specification is approved for use by all Departments and Agencies of the Department of Defense.

1. SCOPE

1.1 Scope. This specification covers the requirements for heat-sealable, greaseproof, flexible barrier materials having low water vapor transmission characteristics for use in military packaging.

1.2 Classification. Barrier materials are furnished in the following classes.

Class 1 - Plastic backing (non-woven)
Class 3 - Scrim backing (woven fabric)

2. APPLICABLE DOCUMENTS

2.1 General. The documents listed in this section are specified in sections 3 and 4 of this specification. This section does not include documents cited in other sections of this specification or recommended for additional information or as examples. While every effort has been made to ensure the completeness of this list, document users are cautioned that they must meet all specified requirements of documents cited in sections 3 and 4 of this specification, whether or not they are listed.

Comments, suggestions, or questions on this document should be addressed to Commanding Officer, Naval Air Warfare Center Aircraft Division Lakehurst, System Standardization and PHS&T Branch, Code BL32600, Mail Stop 120-3, Route 547, Joint Base MDL, NJ 08733-5100 or emailed to LKE-NAVAIRDocCom.fct@navy.mil. Since contact information can change, you may want to verify the currency of this address information using the ASSIST online database at <https://assist.dla.mil>.

MIL-PRF-131L

2.2 Government documents.

2.2.1 Specifications and standards. The following standard forms a part of this document to the extent specified herein. Unless otherwise specified, the issues of this document are those cited in the solicitation or contract.

DEPARTMENT OF DEFENSE STANDARD

MIL-STD-3010 - Test Procedures for Packaging Materials and Containers.

(Copies of this document are available online at <https://quicksearch.dla.mil>.)

2.3 Non-Government publications. The following documents form a part of this document to the extent specified herein. Unless otherwise specified, the issues of these documents are those cited in the solicitation or contract.

AMERICAN SOCIETY FOR QUALITY (ASQ)

ASQ/ANSI Z1.4 - Sampling Procedures and Tables for Inspection by Attributes. (DoD adopted)

(Copies of this document are available online at www.asq.org.)

AMERICAN SOCIETY FOR TESTING AND MATERIALS (ASTM) INTERNATIONAL

ASTM D471 - Rubber Property-Effect of Liquids, Standard Test Method for. (DoD adopted)
ASTM D882 - Tensile Properties of Thin Plastic Sheeting, Standard Test Method for. (DoD adopted)
ASTM F1249 - Water Vapor Transmission Rate Through Plastic Film and Sheeting Using a Modulated Infrared Sensor, Standard Test Method for.

(Copies of these documents are available from www.astm.org.)

2.4 Order of precedence. Unless otherwise noted herein or in the contract, in the event of a conflict between the text of this document and the references cited herein, the text of this document takes precedence. Nothing in this document, however, supersedes applicable laws and regulations unless a specific exemption has been obtained.

3. REQUIREMENTS

3.1 Qualification. The barrier materials furnished under this specification shall be products that are authorized by the qualifying activity for listing on the applicable qualified products list before contract award (see 4.2 and 6.4).

3.2 Material. Barrier materials shall be made from such materials and by such processes as to ensure compliance with the performance requirements of this specification.

3.3 Construction. Barrier materials shall be constructed of one or more plies in any manner which ensures compliance with the performance requirements of this specification. Butting of component materials or the finished product shall not be permitted except in the direction perpendicular to the rolling direction. When a butt weld is made on the finished product or any ply thereof, the areas shall be externally flagged with colored markers to prevent use of that portion of the roll.

3.3.1 Splices. A roll shall not contain more than 3 splices (4 pieces) and each piece shall be not less than 45 yards in length. Splices within rolls shall be even the entire width of the roll material and shall not come apart during unwinding of the roll. Rolls containing splices shall be flagged at both ends of each splice with colored markers to indicate splices within the roll. Barrier material in flat cut sheets shall not contain splices (see 4.3.2.2).

3.4 Form. The barrier material shall be furnished in rolls or flat cut sheets as specified in the contract or order (see 6.2).

3.4.1 Rolls. Unless otherwise specified (see 6.2), the width of roll material shall be 36 inches, with a tolerance of plus $\frac{1}{4}$ inch or minus $\frac{1}{8}$ inch. The average length of roll material shall be not less than 200 yards. The length of any individual roll shall be not less than 195 yards. The roll material shall be uniformly wound on nonreturnable cores. The core's inside diameter shall be not less than 3 inches, with a tolerance of plus $\frac{1}{8}$ inch. The length of the core shall be equal to the width of the roll material, with a tolerance of plus $\frac{1}{8}$ inch. The core shall be rigid to prevent distortion of the roll during use and shipment conditions (see 4.3.2.3). Each roll shall be restrained to prevent unwinding (see 4.3.2.2).

3.4.2 Sheets. When flat cut sheets are specified, the length and width shall be as specified by the procuring activity (see 6.2). If the length and width tolerances for cut sheets are not specified the tolerance for each shall be plus $\frac{1}{4}$ inch or minus $\frac{1}{8}$ inch (see 4.3.2.3). Flat cut sheets shall be uniformly stacked (see 4.3.2.2).

MIL-PRF-131L

3.5 Sealing. Barrier materials shall be heat-sealed under conditions recommended by the manufacturer. These sealing conditions shall be such as are considered reasonable for production line sealing operations with respect to commonly available sealing equipment and commercially practical fabrication time. The material shall exhibit no delamination at the heat-sealed area when sealed under the manufacturer's recommended conditions (see 4.5). Each roll or package (flat cuts) of barrier material shall include a tag secured to the core of rolls, or sheet inserted in the package of sheets with the sealing instructions for heat-sealing on rotary, band, and jaw-type sealing equipment. The tag or sheet shall be visible upon opening the unit package.

3.6 Identification of material. The specification number, class, manufacturer's name, manufacturer's designation, month and year of manufacture, lot number, and heat sealing conditions (temperature, pressure, and dwell time) shall be clearly and legibly marked using water-resistant ink on the backing surface of the material. The color of the markings shall be lusterless red (see 4.3.2.1). The complete markings shall be continuous lengthwise and the distance between groups of markings shall be not greater than 2 inches. A complete group of markings shall appear once in each 18 inches of width of the roll. The letters and figures shall be not less than 1/8 inch high (see 4.3.2.3).

3.7 Performance requirements. The performance of the barrier materials shall conform to the requirements specified in table I, when tested in accordance with 4.6.

3.8 Workmanship. Barrier material surfaces shall be free from any foreign matter. The barrier material edges shall be cut and trimmed of any selvage. Barrier material shall be free from holes, tears, cuts, sharp creases, wrinkles, or other imperfections (see 4.3.2.1).

MIL-PRF-131L

TABLE I. Performance requirements.

Characteristics	Class 1 Requirements	Class 3 Requirements	Test Paragraph Reference
Seam Strength 1. As received material sealed and tested: a. At room temperature (separation-inches) b. At 100 °F and at 160 °F (separation-inches) 2. Sealed before aging at 160 °F for 12 days and tested: a. At room temperature (separation-inches) b. At 100 °F and at 160 °F (separation-inches) 3. Sealed after aging at 160 °F for 12 days and tested: a. At room temperature (separation-inches) b. At 100 °F and at 160 °F (separation-inches)	No separation ¼ (max)	No separation ¼ (max)	4.6.1
Seam fabrication	No leakage at double seam junction	No leakage at double seam junction	4.6.2
Water vapor transmission rate (WVTR) 1. After room temperature flexing: a. As received (gms/100 sq. in./24 hrs.) b. Aged (gms/100 sq. in./24 hrs.) 2. WVTR after low temperature flexing: As received (gms/100 sq. in./24 hrs.)	0.02 (max) 0.02 (max) 0.03 (max)	0.02 (max) 0.02 (max) 0.03 (max)	4.6.1
Water vapor transmission rate (WVTR) (Modulated Infrared Sensor) As received (gms/100 sq. in./24 hrs.)	0.0005 (max)	0.0005 (max)	4.6.4
Breaking strength (Grab Method) a. As received (weakest direction) (lb./inch) b. After aging (weakest direction) (lb./inch)	50 (min) 50 (min)	65 (min) 65 (min)	4.6.5
Puncture resistance (lbs.)	15 (min)	22 (min)	4.6.1
Tear strength (lbs.)	Not required	17 (min)	4.6.6
Backing peel strength (oz./in.)	Not required	7.0 (min)	4.6.7
Aging resistance	No delamination as specified in 4.6.3.1		4.6.3
Blocking resistance	No blocking, delamination, or rupture		4.6.1

MIL-PRF-131L

TABLE I. Performance requirements - Continued.

Characteristics	Class 1 Requirements	Class 3 Requirements	Test Paragraph Reference
Resistance to curl	No curl in excess of 5% or curl back upon itself		4.6.1
Contact corrosivity	No corrosion, etching, or pitting		4.6.1
Oil resistance (delamination)	No leakage, swelling, delamination, or embrittlement		4.6.1
Water resistance	No delamination		4.6.1
Water resistance of marking	Markings on back of sheet shall be clear and legible		4.6.1

4. VERIFICATION

4.1 Classification of inspections. The inspection requirements specified herein are classified as follows:

- a. Qualification inspection (see 4.2).
- b. Conformance inspection (see 4.3).

4.2 Qualification inspection. The qualification inspection shall consist of all tests and examinations of this specification.

4.3 Conformance inspection. Conformance inspections shall consist of the required tests listed in table II and the examinations listed in tables III through V.

TABLE II. Conformance tests.

Characteristics	Paragraph Reference
Seam strength (as received only)	4.6.1
Seam fabrication	4.6.2
Water vapor transmission rate (as received only)	4.6.1
Breaking strength (as received only)	4.6.5
Puncture resistance	4.6.1
Resistance to curl	4.6.1
Tear strength (class 3 only)	4.6.6

MIL-PRF-131L

4.3.1 Sampling for conformance inspection. Unless otherwise specified in the contract or order, sampling for inspection shall be performed in accordance with the provisions set forth in ASQ/ANSI Z1.4.

4.3.2 Examination of the end item. For the purpose of determining the sample size in accordance with ASQ/ANSI Z1.4, the lot size shall be expressed in units of rolls or packages of sheets, as applicable, for examinations under 4.3.2.1 through 4.3.2.3.

4.3.2.1 Examination of the end item for defects in appearance, construction, and workmanship. For examination of defects within rolls, the sample unit of product shall be two yards, the full width of the roll. For examination of sheets, the sample unit shall be two sheets randomly selected from a package. No more than five sample units, randomly selected, shall be drawn from any one roll or package of sheets, as applicable. Both sides of the material shall be examined.

TABLE III. Examination of the end item for defects in appearance, construction, and workmanship.

EXAMINATION	DEFECT
Form	Not roll or flat cut, as specified. Incorrect class of material.
Appearance	Surfaces not clean; presence of any foreign matter, dirt, sand, grit, or oil spots. (Note: Defects do not apply to outer convolution of roll.)
Workmanship	Blister, crack, cut, hole, tear, sharp crease, chafed spot, or scuff mark. (Note: Defects do not apply to outer convolution of roll.) Evidence of delamination or embrittlement. Edges not clean cut; ragged, crushed, or uneven.
Construction	Not uniform; layer or section missing, selvage present.
Identification markings	Illegible, incorrect, incomplete, or omitted. Do not appear on backing surface of material; not continuous lengthwise. Color is not lusterless red.

4.3.2.2 Examination of the end item for defects in general construction. The sample unit for this examination shall be one roll or one package of sheets, as applicable.

MIL-PRF-131L

TABLE IV. Examination of end item for defects in general construction.

EXAMINATION	DEFECT
Assembly of sheets	Not evenly and uniformly stacked; sheet containing manufacturer's sealing conditions not visible upon opening. Adjacent sheets stick together to the extent that separation causes tearing or injury to any surface. Splice within sheet.
Assembly of roll	Not restrained to prevent unwinding. Material not wound uniformly on roll causing soft or uneven edges, or telescoping of roll. Material not wound on a rigid core, core broken, collapsed, crushed, mutilated.
Unwinding of roll (check both sides)	When unwound, material sticks together to the extent that unrolling causes tearing or injury to any surface. Material wound unevenly causing wrinkles, sharp creases, or folds within roll. Roll not continuous; more than 3 splices (4 pieces) in roll or more than 1 splice in any 50 consecutive yards. Splice(s) not evenly made; does not cover entire width of material; comes apart during unwinding of roll.

4.3.2.3 Examination of the end item for dimensional defects. The sample unit for this examination shall be one roll or one package of sheets, as applicable.

TABLE V. Examination of the end item for dimensional defects.

EXAMINATION	DEFECT
Sheets	Length or width varies by more than plus ¼ inch or minus ⅛ inch from dimensions specified.
Rolls: Width	Varies by more than plus ¼ inch or minus ⅛ inch from width specified.
Length	Average length of roll material is less than 200 yards, length of any individual roll is less than 195 yards.
Core	Length is less than width of roll material, or greater by more than plus ⅛ inch. Inside diameter less than 3 inches or greater than 3 ⅛ inches.
Identification markings	Lettering is less than ⅛ inch in height. More than 2 inches distance between lengthwise group of markings. The complete group does not appear once in each 18 inches of width of roll.

MIL-PRF-131L

4.4 Test conditions. Unless otherwise specified in the detail test methods herein, the physical tests contained in this specification shall be made with an atmosphere having a relative humidity of 50 ± 5 percent and a temperature ranging from 73 ± 3 °F. Material shall be considered in equilibrium after exposure to the above conditions for a minimum of 24 hours.

4.5 Sealing instructions for qualification and conformance testing.

a. All seals for test purposes shall be not less than ½-inch wide and shall be effected on a jaw-type heat-sealer (or equivalent as approved by the qualifying activity) utilizing the sealing conditions recommended by the manufacturer. These conditions shall be limited as follows (see 6.3):

- (1) Maximum temperature = 500 °F
- (2) Maximum dwell time = 3 seconds
- (3) Maximum pressure = 60 lbs./sq. in.

b. In the securing of the three 1-inch seam strength specimens from their respective samples, specimens shall not be removed:

- (1) From points in the sealed sample where seal overlapping has occurred.
- (2) From points in the sealed sample that were within 1-inch of either end of the sealer jaw during the sealing operation.

4.6 Verification of performance requirements.

4.6.1 MIL-STD-3010 test methods. Unless otherwise specified, the tests in table VI shall be conducted in accordance with the identified methods of MIL-STD-3010.

MIL-PRF-131L

TABLE VI. Test methods.

Tests	MIL-STD-3010 Test Method No.	Special Requirement or Exception Note
Seam strength	2024	<u>1/</u>
Water vapor transmission rate after room temperature flexing (as received and aged) Transmission rate procedure	2017 3030	<u>2/</u> --
Water vapor transmission rate after low temperature flexing (as received only) Transmission rate procedure	2017 3030	<u>3/</u> --
Puncture resistance	2065	<u>4/</u>
Blocking resistance	3003	--
Resistance to curl	2015	<u>5/</u>
Contact corrosivity	3005	<u>6/</u>
Oil resistance (delamination)	3015	<u>7/</u>
Water resistance	3028	<u>8/</u>
Water resistance of marking	3027	<u>9/</u>

- 1/ Any evidence of delamination of one ply away from the other in the heat-sealed area shall be cause for rejection. The evaluation shall be limited to the heat-sealed area.
- 2/ Full stroke shall be used for flexing all class 1 materials.
- 3/ Conduct tests as specified in MIL-STD-3010, Method 2017, except that only as received specimens shall be tested. Prior to flexing, test specimens shall be conditioned for at least 30 minutes at -20 ± 2 °F and the flexing operation shall be conducted at -20 ± 2 °F.
- 4/ Test shall be run on five specimens. Material under test shall have the heat-sealable face in contact with the probe. The average value of the five specimens tested shall meet the requirement specified in table I.
- 5/ Three specimens shall be tested.
- 6/ If corrosion is evident in the non-contact area, the test shall be repeated with a new test panel. Corrosion in the intermediate area shall not invalidate the test nor be cause for rejection. The barrier material shall be evaluated individually.
- 7/ Oil conforming to ASTM D471, and a di-2-ethylhexyl sebacate synthetic oil shall both be used.
- 8/ Use distilled water. Delamination shall be measured as ply separation at any one given point extending more than ½ inch from the edge, with an edge length separation greater than one inch.
- 9/ Three specimens shall be tested, each one containing a complete set of markings.

MIL-PRF-131L

4.6.2 Seam fabrication.

4.6.2.1 Preparation of test specimens. Four pouches sealed in accordance with the manufacturer's recommended sealing conditions shall be fabricated from the barrier material. Each pouch shall be prepared by cutting four specimens; two 2 ½ by 5 ½ inches and two 5 ½ inches by 5 ½ inches. The pouch shall be fabricated by sealing as shown on figure 1. The butt seals projecting at ½ inch seams perpendicular to the faces shall be made prior to sealing the bottom. The butt seams shall be folded flat at the point of juncture with the bottom seams before the bottom seals are made.

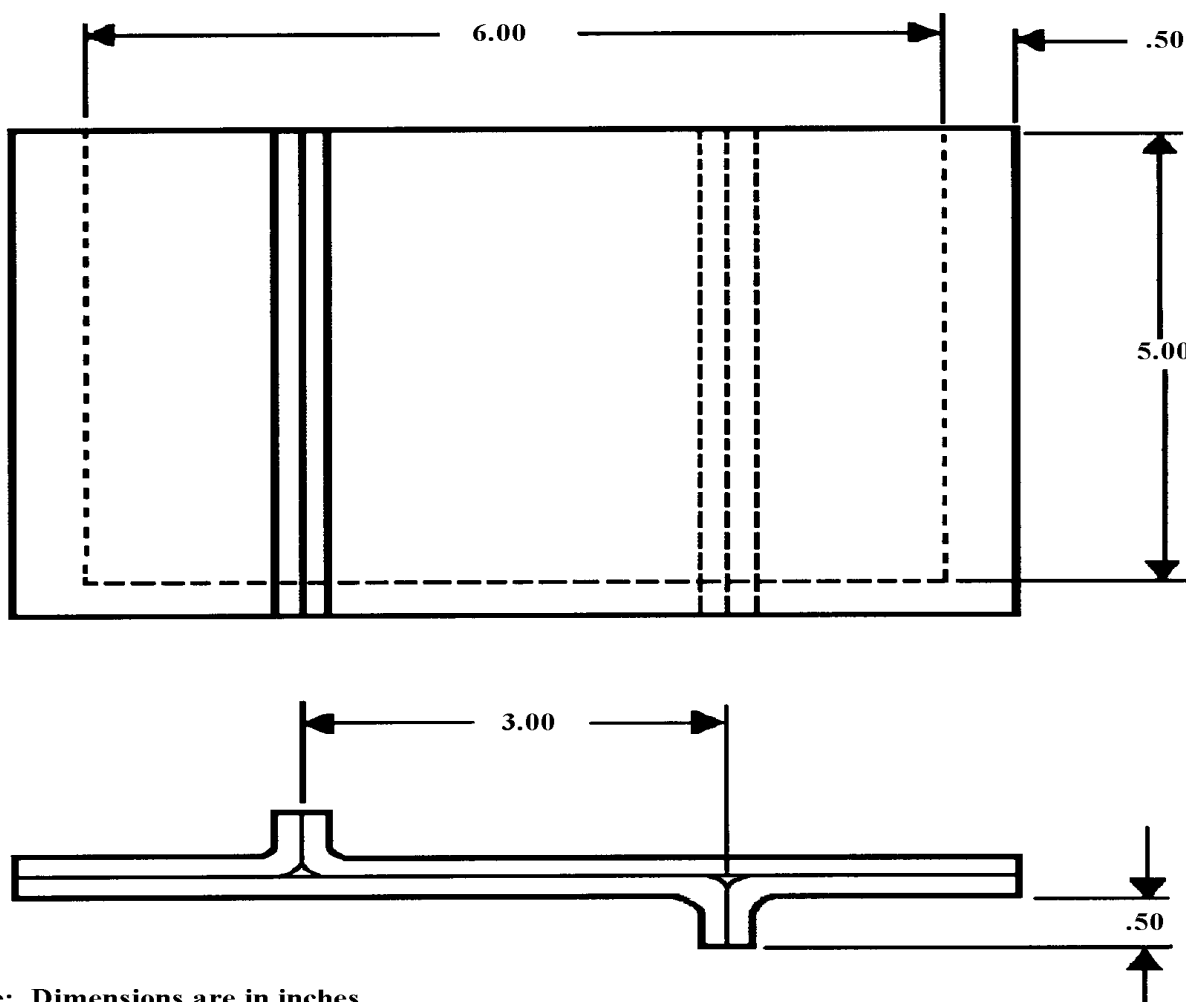

Note: Dimensions are in inches.

FIGURE 1. Pouch for seam fabrication test.

MIL-PRF-131L

4.6.2.2 Procedure. A water solution, containing dye and 1 percent sodium dioctyl sulfosuccinate as approved by the qualifying activity, shall be made to produce a distinct color. The solution shall be poured into each sealed pouch to a level of two inches above the top of the bottom seam. The pouches shall then be suspended vertically. After a period of 15 minutes at room temperature, the pouches shall be examined for dye leakage at all seams and especially at the double seam junctions (the points where the vertical seams intersect the bottom seam at points other than at the corners of the pouch) by blotting with white tissue.

4.6.3 Aging resistance. Three specimens, 36 by 6 inches, cut from across the roll of material, at points which shall be not less than 1 yard apart, shall be used for this test.

4.6.3.1 Procedure. The specimens shall be subjected to the following aging cycle:

8 hours in a humidity chamber of 100 ± 2 °F and 90 to 95 percent relative humidity.
16 hours in a circulating air oven at 160 ± 2 °F.

The aging cycle shall be repeated every weekday, for five consecutive days. The specimens shall remain in the circulating air oven maintained at the conditions described above on Saturday, Sunday and holidays, except that holidays shall not exceed a total of two days over the entire aging period. The aging procedure shall continue for fourteen consecutive days. The specimens shall be folded loosely, hung, rolled loosely or laid flat in the test chamber during the aging period. At the conclusion of the aging period the specimens shall be returned to room temperature and examined, particularly at all edges, for delamination brought about by the aging exposure. No supplemental attempt to delaminate the material, such as prying or picking at the plies, shall be carried out. Delamination shall be measured as ply separation at any one given point extending more than ½ inch from the edge, with an edge length separation greater than one inch.

4.6.4 WVTR (modulated infrared sensor). A suitably sized sample of material shall be installed on a calibrated device for measuring moisture permeation through an area of approximately 50 cm² in accordance with ASTM F1249. The surface of the sample designed for heat sealing shall be oriented toward the dry carrier gas with the other side oriented toward a 100 percent relative humidity environment. The test temperature shall be 100 °F (38 °C). The material shall be tested for permeation, allowing a minimum of 80 hours to reach steady state. Three samples shall be tested and the results averaged.

4.6.5 Breaking strength. Five specimens 4 by 6 inches shall be cut with the long dimension parallel to the machine direction and another five specimens of the same size cut in the transverse direction. Specimens shall be marked with a line parallel to a long edge and 1½ inches from it. Clamps shall be rubber-faced pneumatic grips with the gripping surface 1 by 1 inch. Initial grip separation shall be $2 \pm \frac{1}{2}$ inches. Each specimen shall be installed by aligning the marked line with the inside edge of the grips, allowing approximately the same amount of material protruding from the top of the top grip as from the bottom of the bottom grip. Test speed

MIL-PRF-131L

shall be 20 inches per minute. Specimens shall be tested in accordance with ASTM D882, obtaining an average result for each direction. Breaking strength shall be the lowest average result of the two directions. Breaking strength shall also be determined with aged material which has been exposed to an atmosphere of 80 to 85 percent relative humidity and 160 ± 2 °F for 72 consecutive hours. Aging shall be accomplished on a large sheet of material with individual test specimens cut from the aged sheet. Again, breaking strength shall be the lowest average result of the two directions.

4.6.6 Tear strength (class 3 only). Five specimens 3 by 6 inches shall be cut with the short dimension parallel to the machine direction and another five specimens of the same size cut in the transverse direction. Each set of specimens shall be tested as-received for maximum tearing load in accordance with ASTM D882 (in conjunction with the test method listed below), obtaining an average result for each direction. Clamps shall be rubber-faced pneumatic grips and shall be 3 inches in width (perpendicular to the application of force) and at least 1 inch in height. Initial grip separation shall be 1 ± 0.05 inch. Test speed shall be $12 \pm \frac{1}{2}$ inches per minute. Tear strength shall be the lowest average result. An outline of an isosceles trapezoid is marked on a rectangular specimen cut for the determination of tearing strength (see figure 2). The specimen is slit at the center of the smallest base of the trapezoid to start the tear (see figure 3). The nonparallel sides of the trapezoid marked on the specimen are clamped in parallel jaws of a tensile testing machine. The separation of the jaws is continuously increased to apply a force to propagate the tear across the specimen.

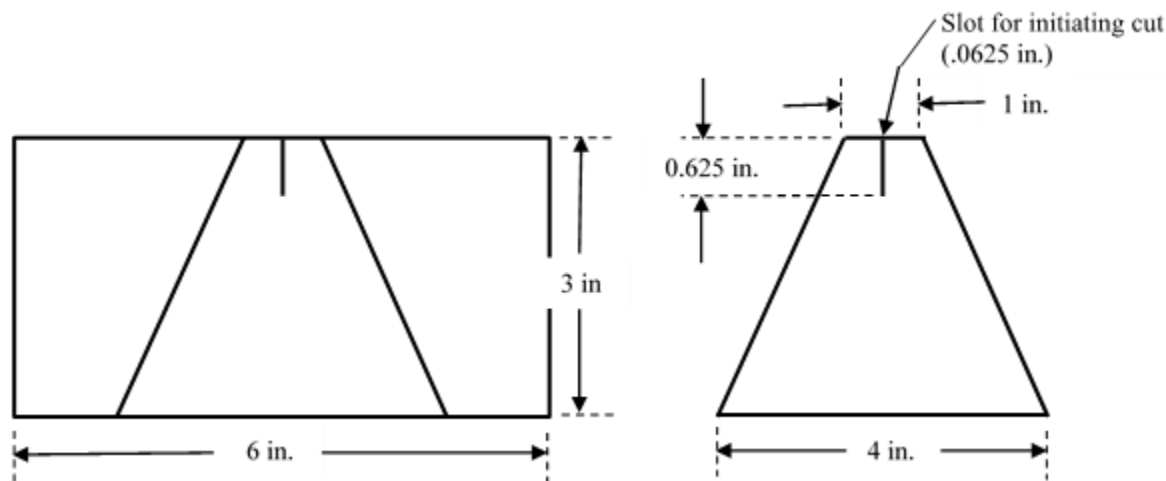

FIGURE 2. Diagram of marked trapezoid specimen.

FIGURE 3. Specimen marking template.

MIL-PRF-131L

4.6.7 Backing peel strength (class 3 only). Five specimens 1 by 6 inches shall be cut with the long dimension parallel to backing warp and another five specimens of the same size cut with the long dimension parallel to the backing fill. Each specimen shall be prepared by peeling the woven backing approximately 2 inches from one end. A T-peel test shall be effected using rubber-faced pneumatic grips with the gripping surfaces 1 by 1 inch. Initial grip separation shall be 1 inch. Test speed shall be $12 \pm \frac{1}{2}$ inches per minute. Peel distance shall be the distance the movable grip travels after the first significant load is recorded. Peel strength shall be determined by measuring the mean load over a peel distance of 1 to 5 inches and dividing by the width of the specimen.

5. PACKAGING

5.1 Packaging. For acquisition purposes, the packaging requirements shall be as specified in the contract or order (see 6.2). When packaging of materiel is to be performed by DoD or in-house contractor personnel, these personnel need to contact the responsible packaging activity to ascertain packaging requirements. Packaging requirements are maintained by the Inventory Control Point's packaging activities within the Military Service or Defense Agency, or within the military service's system commands. Packaging data retrieval is available from the managing Military Department's or Defense Agency's automated packaging files, CD-ROM products, or by contacting the responsible packaging activity.

6. NOTES

(This section contains information of a general or explanatory nature that may be helpful, but is not mandatory.)

6.1 Intended use. The barrier materials covered by this specification are intended for use in specialized military methods of preservation. The combination of all performance characteristics of MIL-PRF-131; seam strength and fabrication; water vapor transmission rate; breaking strength; puncture, blocking and curl resistance; contact corrosivity; delamination; and water resistance of markings provide the necessary requirements for protection from exposure to the extremes of the navy/naval aviation environment. Navy/naval aviation items are exposed to high moisture, high salt concentration, transfer at sea, rough handling, and minimal storage conditions. There are no commercial equivalents that meet the physical, mechanical, and corrosion requirements necessary to protect materiel that is exposed to the operational naval aviation environment. Specifically, Methods 41, 42, 43, 51, 52, and 53 of MIL-STD-2073-1 use MIL-PRF-131 as the premier source of barrier materials that provide watervaporproof (and watervaporproof with desiccant) protection for applicable items encountering the above conditions.

MIL-PRF-131L

6.1.1 Class 1 (general use). Class 1 material with plastic non-woven backing is intended to be used in all packaging applications where heat-sealable, flexible, watervaporproof, greaseproof, barrier materials are required.

6.1.2 Class 3 (specialized use). Class 3 is similar to Class 1 but is used for those applications where a higher strength heat-sealable, flexible, watervaporproof, greaseproof barrier material is required.

6.2 Acquisition requirements. Acquisition documents should specify the following:

- a. Title, number, and date of the specification.
- b. Class of barrier material (see 1.2).
- c. Form (rolls or flat cut sheets) and size required (see 3.4).
- d. Packaging requirements (see 5.1).

6.3 Heat-seal equipment. In the interest of standardization and for ease of manipulation, all seals for test under this specification should be effected on a jaw-type heat-sealer. This, however, should not be construed as an indication of Governmental preference in regard to sealing equipment. It is not intended that the operating temperature of heat-sealing equipment be limited to 500 °F or less. While equipment may be operated at temperatures exceeding 500 °F to accomplish a seal, the barrier material should also be capable of being heat-sealed at temperatures of 500 °F or less.

6.4 Qualification. With respect to products requiring qualification, awards will be made only for products which are, at the time of award of contract, qualified for inclusion in QualifiedProducts List QPL-131 whether or not such products have actually been so listed by that date. The attention of the contractors is called to these requirements, and manufacturers are urged to arrange to have the products that they propose to offer to the Federal Government tested for qualification in order that they may be eligible to be awarded contracts or orders for the products covered by this specification. Information pertaining to qualification of products and the letter of authorization for submittal of sample may be obtained from: Commander, Naval Air Warfare Center Aircraft Division Lakehurst, System Standardization and PHS&T Branch, Code BL32600, Mail Stop 120-3, Route 547, Joint Base MDL, NJ 08733-5100. An online listing of products qualified to this specification may be found in the Qualified Products Database (QPD) at <https://assist.dla.mil>.

Barrier material supplied under contract should be identical in every respect to the samples tested and found to meet the requirements of this specification. Any unapproved changes from the qualification sample should constitute cause for rejection for material submitted and for removal from the list of qualified products. However, acceptability under this specification is

MIL-PRF-131L

based on the performance characteristics of the barrier material, and since there is no color requirement, it is not mandatory that the color of the visible surfaces of the material supplied under contract be the same as the samples tested and accepted by the qualifying activity.

6.5 Conformance inspection lot. For purposes of sampling, an inspection lot for examinations and tests should consist of all material of the same class made by the same process from the same components by one manufacturer and submitted for delivery at one time.

6.6 Safety Data Sheet (SDS). An SDS must be prepared and submitted in accordance with FED-STD-313 (obtain from <https://assist.dla.mil>). The SDS must also meet the requirements of 29 CFR 1910.1200. The 29 CFR 1910.1200 requires that the SDS for each hazardous chemical used in an operation must be readily available to personnel using the material. Questions pertinent to the effect(s) of these cleaners on the health of personnel using them should be referred by the procuring activity to the appropriate medical service, who will act as its adviser. Contracting officers will identify the activities requiring copies of the SDS.

6.7 Subject term (key word) listing.

- Packaging
- Plastic backing
- Preservation
- Water vapor transmission

6.8 Cross reference.

MIL-B-131H	MIL-PRF-131J	MIL-PRF-131K	MIL-PRF-131L
Type I, Class 1	Class 1	Class 1	Class 1
Type I, Class 2	Class 2	Class 2	Deleted
Type I, Class 3	Deleted	Class 3 (added)	Class 3
Type II	Deleted	Deleted	Deleted

6.9 Changes from previous issue. Marginal notations are not used in this revision to identify changes with respect to the previous issue due to the extent of the changes.

MIL-PRF-131L

CONCLUDING MATERIAL

Custodians:

Army - GL
Navy - AS
Air Force - 11

Preparing activity:

Navy - AS

(Project 8135-2022-001)

Review activities:

Army - AT, CR, EA, MI, SM
Navy - OS, SA, SH
DLA - CC, SS

NOTE: The activities listed above were interested in this document as of the date of this document. Since organizations and responsibilities can change, you should verify the currency of the information above using ASSIST Online database at <https://assist.dla.mil>.