

**NOT MEASUREMENT
SENSITIVE**

MIL-STD-331C
w/CHANGE 1
22 June 2009

SUPERSEDING
MIL-STD-331C
5 JANUARY 2005

DEPARTMENT OF DEFENSE TEST METHOD STANDARD

FUZE AND FUZE COMPONENTS,
ENVIRONMENTAL AND PERFORMANCE TESTS FOR



AMSC N/A

FSG 13GP

DISTRIBUTION STATEMENT A. Approved for public release; distribution is unlimited.

FOREWORD

1. This standard is approved for use by all Departments and Agencies of the Department of Defense.

2. MIL-STD-331C supersedes MIL-STD-331B, dated 1 December 1989, including all change notices. It has been prepared in accordance with MIL-STD-962C and complies with DoD policy for greater use of commercial products and practices.

3. MIL-STD-331 is a test method type standard. Its scope has evolved over the years reflecting increased standardization of environmental and performance tests among the services and improvements in fuze design, test technology and safety. MIL-STD-331B was largely an editorial effort to consolidate test methods and restructure the standard. Attention is directed to the test grouping and use of standard, alternate and optional test methods described in sections 5.2 and 5.4 respectively.

4. In the process of reorganization, tests were renumbered. Where old test numbers are still referenced in fuze specifications and test plans, Table I is included to show the correspondence between prior test numbers and the new numbers.

5. Design agencies are cautioned that the existence of this standard does not relieve them of the responsibility to define the environments the fuze will be exposed to during its life cycle. This definition is essential for proper test selection and the identification of any required test deviation. Specification of the test method alone in a test directive may not adequately define the conditions in which a test is conducted. Many test methods in this standard include parameters or options which permit tailoring to specific fuze designs, environments and uses. Table II results from the concern for properly invoking the use of test methods. The use of Table II and careful review of the entire test method is strongly encouraged when preparing development or production specifications and test plans.

6. Paragraph numbers in each test have been modified to include the test method number. Although this makes the numbers longer, each paragraph in the standard is now uniquely identified. This is intended to reduce confusion when referencing specific material.

7. MIL-STD-331C includes three new tests (D6, D7 and D8) and two revised tests (F2.1 and F4.1). Test D6, Brush Impact No-Fire Test has been included to verify the performance of an armed anti armor munition demonstrating it will penetrate light foliage such as brush. Test D7, Mortar Ammunition Fuze Double Loading Test has been included to determine, in the event of double loading, whether the contour of the ogive of the projectile fuze can initiate the round dropped on it. Test D8, Progressive Arming Test has been included to determine the correlation between the position of the explosive train interrupter and the probability of explosive transfer.

8. Test B1.1, Transportation Vibration (Bare and Packaged Fuzes), replaces both Tests B1 and B2. It employs the use of random vibration test techniques and can be tailored to various land, sea and air transportation scenarios. All former sinusoidal vibration test methods have been retained as alternate tests in Section B1.6 and may be specified for procurement of older fuzes which cannot comply with the requirements of the random vibration test schedules.

9. Design agencies which frequently use other fuze and explosive component tests or variations of tests contained in this standard are requested to furnish this information to the preparing activity (see address above) for possible inclusion in MIL-STD-331.

10. Comments, suggestions, or questions on this document should be addressed to: US Army, Research, Development and Engineering Command, Armament Research, Development and

MIL-STD-331C
w/CHANGE 1

Engineering Center, ATTN: RDAR-QES-E, Picatinny Arsenal, NJ 07806-5000 or emailed to ardecstdzn@conus.army.mil. Since contact information can change, you may want to verify the currency of this address information using the ASSIST Online data base at <http://assist.daps.dla.mil>.

SUMMARY OF CHANGE 1 MODIFICATIONS

1. Test C1 - Temperature and Humidity, TABLE C1-1 and TABLE C1- II: the start and stop times on two-cycle days were corrected.
2. Test D1 - Primary Explosive Component Safety Test: a second part was added to determine the numerical effectiveness of the interrupter.
3. Test D1 - Primary Explosive Component Safety Test, section D1.6 - Alternate and Optional Tests: the Missing Barrier Test was added; the paragraphs for the cookoff test for projectile fuzes and the fast cookoff test for fuzes were deleted.
4. Test D1 - Primary Explosive Component Safety Test, section D1.7.2 - Bibliography: the bibliography was updated.
5. Test D2 - Arming Distance Test, section D2.5.1 - Arming procedure: the four statistical methods listed were removed and transferred to Appendix G.
6. Test D-8 - Progressive Arm Test: the use of this test to determine the numerical effectiveness of the interrupter was addressed. Definitions and procedures for testing pyrotechnic trains were added.
7. Appendix G - Statistical Methods to Determine the Initiation Probability of One-Shot Devices: this is a new Appendix to the document. The four statistical methods removed from Test D2 are included in this Appendix while the Neyer D-Optimal method was added as a fifth method.
8. Typographical and formatting errors were corrected throughout the document.

CONTENTS

Section	Page
1 SCOPE	1
1.1 Scope	1
1.2 Safety and Suitability for Service Assessment of Fuzing Systems	1
1.2.1 NATO	1
1.2.1.1 STANAG 4157	1
1.3 Application	3
1.4 Test identification	3
1.5 Method of revision	3
1.6 Method of reference	3
2 APPLICABLE DOCUMENTS	3
2.1 Government documents	3
2.1.1 Specifications, standards and handbooks	3
2.1.2 Other Government documents, drawings and publications	4
2.2 Non-Government publications	5
2.3 Order of precedence	6
3 DEFINITIONS	6
4 GENERAL REQUIREMENTS	8
4.1 Test usage	8
4.2 Test compliance	8
4.3 Selection and specification of tests	8
4.4 Test equipment	8
4.4.1 Capability	8
4.4.2 Accuracy	8
4.5 Test conditions	9
4.5.1 Installation of test item	9
4.5.2 Tolerance of test conditions	9
4.5.2.1 Temperature	9
4.5.2.2 Pressure	9
4.5.2.3 Relative humidity	9
4.5.2.4 Vibration amplitude	9
4.5.3 Preconditioning and stabilization	9
4.6 Examination and test criteria	9
4.6.1 Visual examination	9
4.6.2 Criteria for passing tests	10
4.6.2.1 Safe	10
4.6.2.2 Operable	10

4.7 Safety condition	10
4.8 Test documentation	10
4.8.1 Test directive	10
4.8.2 Test item record	11
4.8.2.1 Condition before test	11
4.8.2.2 Condition during test	11
4.8.2.3 Condition after test	11
4.8.3 Test equipment	11
4.8.4 Test conditions	11
4.8.5 Test results	12
5 DETAILED REQUIREMENTS	12
5.1 Individual tests	12
5.2 Test classification	12
5.2.1 Group A - Mechanical Shock Tests	12
5.2.2 Group B - Vibration Tests	12
5.2.3 Group C - Climatic Tests	12
5.2.4 Group D - Safety, Arming and Functioning Tests	12
5.2.5 Group E - Aircraft Munition Tests	12
5.2.6 Group F - Electric and Magnetic Influence Tests	12
5.3 Test number conversion	12
5.4 Invoking tests	13
5.4.1 Alternate and optional tests	13
5.4.2 Test parameters	13
6 NOTES	13
6.1 Background information	13
6.1.1 Safety	13
6.1.2 Short operational time	13
6.1.3 One-time operation	13
6.2 Test content and format	14
6.2.1 Purpose	14
6.2.1.1 Location	14
6.2.1.2 Safety, reliability or performance	14
6.2.1.3 Life cycle phase	14
6.2.1.4 Environment or performance measurement	14
6.2.2 Description	14
6.2.2.1 General	14
6.2.2.2 Fuze configuration	14
6.2.2.3 Variations	14
6.2.2.4 Applicable publications	14
6.2.2.5 Test documentation	15
6.2.3 Criteria for passing test	15
6.2.3.1 Fuze condition	15
6.2.3.2 Decision basis	15
6.2.4 Equipment	15

6.2.5 Procedure	15
6.2.6 Alternate and optional tests	15
6.2.7 Related information	15
6.2.8 Illustrations and tables	16
6.3 Units of measure	16
6.4 Test characteristics	17
6.5 Subject term (key word) listing	17
6.6 Changes from previous issue	17
6.7 Useful references	17

Appendix A - Mechanical Shock Tests

A1 Jolt	28
A2.1 Jumble	33
A3 Twelve-meter (40-Foot) Drop	37
A4.1 One and One-half Meter (Five-Foot) Drop	40
A5 Transportation Handling (Packaged Fuzes)	43

Appendix B - Vibration Tests

B1.1 Transportation Vibration (Bare and Packaged Fuzes)	54
B2 (Requirement are now in Test B1.1)	98
B3 Tactical Vibration	99

Appendix C - Climatic Tests

C1 Temperature & Humidity	118
C2 Vacuum-Steam-Pressure	124
C3 Salt Fog	128
C4 Waterproofness	133
C5 Fungus	135
C6 Extreme Temperature	139
C7 Thermal Shock	142
C8 Leak Detection	146
C9 Dust	152
C10 Solar Radiation	155

Appendix D - Safety, Arming and Functioning Tests

D1 Primary Explosive Component Safety	163
D2 Projectile Fuze Arming Distance	171
D3 Time to Air Burst	174
D4 Explosive Component Output	181
D5 Rain Impact	192
D6 Brush Impact No-Fire	195
D7 Mortar Ammunition Fuze Double Loading	204
D8 Progressive Arming Test	207

Appendix E - Aircraft Munition Tests

E1 Jettison	210
-------------	-----

E2 Low Altitude Accidental Release	213
E3 Arrested Landing Munition Pull-off	215
E4 Catapult and Arrested Landing Forces	218
E5 Simulated Parachute Air Delivery	221

Appendix F - Electric and Magnetic Influence Tests

F1 Electrostatic Discharge (ESD)	225
F2 High-Altitude Electromagnetic Pulse	235
F3 Electromagnetic Radiation Hazards(HERO)	245
F4 Electromagnetic Radiation, Operational preparation(EMRO)	251

Appendix G - Statistical Methods to Determine the Initiation Probability of One-Shot Devices

G1 Purpose	260
G2 Description	260
G3 Methods	260
G3.1 Probit Method	260
G3.2 Langlie Method	262
G3.3 OSTR Method	264
G3.4 Bruceton Method	267
G3.5 Neyer D-Optimal Method	268
G4 Related Information	271
G5 Bibliography	272
G6 Glossary	272

1. SCOPE

1.1 Scope. This standard describes tests used by the Department of Defense (DoD) to determine the safety, reliability and performance characteristics of weapon system fuzes and fuze components at any stage in their life cycle.

1.2 Safety and Suitability for Service Assessment of Fuzing Systems. The central objective of Safety and Suitability for Service (S3) of Fuzing Systems is to confirm and document that the fuzing system is safe and performs as intended in all expected service environments. In the U.S., each service has a Board that reviews the compliance of fuzing systems with the requirements of MIL-STD-1316 and the result of fuzing tests conducted in accordance with the procedures described in MIL-STD-331.

1.2.1 NATO. A similar process has been agreed by NATO's AC/326 SG2, with the design safety requirements standards being STANAG 4187 and the fuze procedures document being Allied Ordnance Publication 20 (AOP-20). In addition, SG2 has agreed on STANAG 4157, Edition 2, S3, Fuzing Systems: Test Requirements for Assessment of Safety and Suitability for Service, which is based on the principles of AOP-15, Safety and Suitability for Service of Munitions and Explosives. Both NATO and the DoD Fuze Engineering Standardization Working Group (FESWG) have agreed that, given their similar objectives, MIL-STD-331 and AOP-20 will be published as one document. Background information on the objectives and requirements of STANAG 4157 is provided below to allow MIL-STD-331 users to understand and apply the principles of S3 assessment in their use of this publication.

1.2.1.1 STANAG 4157. The primary intent of STANAG 4157 is to require NATO nations conduct S3 assessments of all new fuzing systems, and maintain on-file for provision (upon justified request) to other nations a Fuzing System S3 Assessment file containing all design reviews, test results, and the overall national assessment. Table 1 of STANAG 4157 lists the National Fuze S3 Assessment Authorities for NATO nations which have agreed to the provisions. This includes the separate agencies for the U.S. Air Force, Army and Navy.

STANAG 4157 requires that nations conduct tests in accordance with test procedures described in AOP-20, selected from Tables 2 and 3 in accordance with an agreed methodology described as follows:

- a. Table 2 lists the tests that have been agreed by NATO as being mandatory for conduct of a standardized S3 assessment of a fuzing system. It is important to note that these are not necessarily all of the tests that will be required for national qualification of a fuzing system, as specifying qualification requirements is a national responsibility. Also, nations may waive one or more of the tests listed in Table 2, if they can justify why conduct of the test is not required.
- b. Table 3 lists the fuzing system tests that nations should consider including in their qualification test programs. While not mandatory for standardized S3 assessments of fuzing

systems, conduct of a number of these tests will generally be required for qualifying a specific fuzing system. As for the tests listed in Table 2, the test procedures for the Table 2 tests are provided in AOP-20.

STANAG 4157, includes general provisions for selecting test quantities and pass/fail criteria, as well as tailoring test procedures:

- a. Tailoring of Environmental Test Procedures: The standardized tests described in AOP-20 may be tailored in accordance with the following general principles:
 - (1) the environment to be simulated should be at least as severe as the expected service environment for the fuze;
 - (2) given their generally greater sensitivity to the service environment, fuzes warrant testing in more severe environments than the munitions in which they are installed;
 - (3) the rationale used in tailoring the standard environmental tests should be documented and retained as part of the S3 assessment file; the rationale could include avoiding duplication of tests conducted to meet national fuze standards.

- b. Electromagnetic Environment Testing: Testing of fuzes in service electromagnetic (EM) environments is conducted with two primary objectives:
 - (1) confirming that the fuze electronics will remain suitable for service after exposure to worst-case environments; and
 - (2) confirming that fuze safety is not degraded for fuzes employing electric detonators, or fuzes employing electronic circuits controlling all or part of the safety-and-arming system.

- c. The safety and suitability test requirements for fuzes should be based on all scenarios examined in the Fuze Design Safety Hazard Assessment (conducted in accordance with STANAG 4187 (or MIL-STD-1316), and must include confirmation that:
 - (1) the energy passed through the initiating element of the fuze explosive train produced by a service EM environment will not exceed the factored no-fire safety threshold, as defined in STANAG 4187 (or MIL-DTL-23659); and
 - (2) the service EM environment will not degrade safety or suitability by damaging or upsetting the electronic circuitry controlling the safety-and arming and initiation systems, respectively.

- d. Quantities: Quantities should be selected so as to provide statistically meaningful results and should reflect the quantities used in previous assessments of similar fuzes which subsequently entered into service. The overall objective should be to both meet national requirements and provide a convincing demonstration of fuze safety and suitability for service to other participating nations. The approval of the quantities of fuzes to be

subjected to the mandatory and recommended tests is the responsibility of the National Safety Approving Authority (normally, the agencies listed in Table 1).

- e. **Pass/Fail Criteria:** The general criterion for passing any of the mandatory and recommended tests is that an unsafe condition not be observed during the test or upon examination of the fuze after the test. Given the relatively small sample sizes generally employed, one observed unsafe condition generally constitutes a failure. Depending upon the fuze or system design requirement, a small decrease in fuze performance may be acceptable if safety is not affected; large degradations in fuze performance indicate that the fuze is not acceptable for service use. Pass/fail criteria are provided in the test procedures, where appropriate.

1.3 Application. This standard generally applies to all fuzes, as well as components of weapon systems serving a fuze function, such as torpedo exploders and underwater mine firing mechanisms.

1.4 Test identification. The detailed requirements are documented as individual tests and contained as appendices to this standard. Each test is identified by an alpha-numeric sequence which begins with a letter indicating the test group. This is followed by a sequentially-assigned number.

1.5 Method of revision. Tests are revised on an individual basis and issued as change notices when required. Revised tests are identified by a decimal number after the test number. Revised test parameters affecting test results apply to fuzes developed subsequent to the change notice. All current test requirements are described in the first five sections of the test. Superseded test requirements with applicable dates are located in Section 6 of the test and identified as alternate tests for older fuzes.

1.6 Method of reference. Specific tests or test sequences may be invoked by the developing or procuring agency within a formal engineering development test plan or procurement specification. Additionally, many tests permit variations which should be selected at the time the test is invoked. Variations may include test configuration, materials, methods, sample size or pass/fail criteria. Decimal number revisions are not to be referenced.

2. APPLICABLE DOCUMENTS

2.1 Government documents.

2.1.1 Specifications, standards, and handbooks. The following specifications, standards, and handbooks form a part of this document to the extent specified herein. Unless otherwise specified, the issues of these documents are those cited in the solicitation or contract.

FEDERAL SPECIFICATIONS

QQ-L-201

Lead Sheet

DEPARTMENT OF DEFENSE SPECIFICATIONS

MIL-T-18404	Torpedoes, Environmental Requirements, General Specifications for
MIL-DTL-23659	Initiators, Electric, General Design Specifications for

DEPARTMENT OF DEFENSE STANDARDS

MIL-STD-167-1	Mechanical Vibrations of Shipboard Equipment (Type I - Environmental and Type II - Internally Excited)
MIL-STD-167-2	Mechanical Vibrations of Shipboard Equipment (Reciprocating Machinery and Propulsion System and Shaft, Types III, IV and V)
MIL-STD-202	Test Methods for Electronic and Electrical Component Parts
MIL-STD-322	Explosive Components, Electrically Initiated, Basic Evaluation Tests for
MIL-STD-461	Requirements for the Control of Electromagnetic Interference Characteristics of Subsystems and Equipment
MIL-STD-464	Electromagnetic Environmental Effects Requirements for Systems
MIL-STD-810	Environmental Engineering Considerations and Laboratory Tests
MIL-STD-1316	Fuze Design, Safety Criteria for

DEPARTMENT OF DEFENSE HANDBOOKS

MIL-HDBK-310	Global Climatic Data for Developing Military Products
MIL-HDBK-1512	Electroexplosive, Subsystems, Electrically Initiated, Design Requirements and Test Methods

(Copies of these documents are available online at <http://assist.dla.mil/quicksearch/> or <http://assist.daps.dla.mil> or from the Standardization Document Order Desk, 700 Robbins Avenue, Building 4D, Philadelphia PA 19111-5094.)

2.1.2 Other Government documents, drawings and publications. The following other Government documents, drawings and publications form a part of this standard to the extent specified herein. Unless otherwise specified, the issues are those cited in the solicitation.

DRAWINGS

81-3-35 (Army)	Machine, Jumble Testing, Assembly
----------------	-----------------------------------

81-3-37 (Army)	Machine, Jumble Testing, Assembly
9 255 299 (Army)	Jolt Machine
40 897 (Navy)	Drop Tower Construction
QEL 1386-1 to -45 (Navy)	Jumble Machine
QEL 1387-1 (Navy)	Jumble Machine Modification
OS 6341 (Navy)	General Ordnance Design Requirements

TECHNICAL MANUALS

OD 7547 (Navy)	Vacuum-Steam-Pressure Accelerated Aging Chamber
----------------	-------------------------------------------------

ARMY REGULATIONS

AR 70-38	Research, Development, Test and Evaluation of Materiel for Extreme Climatic Conditions
AR 700-15	Packaging of Materiel

(Copies of drawings and publications required by contractors for specific acquisitions should be obtained from the contracting activity.)

2.2 Non-Government publications. The following documents form a part of this document to the extent specified herein. Unless otherwise specified, the issues of the documents are those specified in the solicitation or contract.

AMERICAN SOCIETY FOR TESTING MATERIALS (ASTM)

ASTM-A108	Steel Bars, Carbon, Cold-Finished, Standard Quality
ASTM-A109/A109M	Steel, Strip, Carbon, (0.25 Maximum Percent) Cold-Rolled
ASTM-C208	Board Insulating Cellulosic Fiber
ASTM-D880	Impact Testing for Shipping Containers and Systems, Standard Test Method For
ASTM-D6199	Wood Members of Containers and Pallets, Quality of
ASTM-G21	Materials to Fungi, Synthetic Polymeric, Determining Resistance of
ASTM-G22	Bacteria, Determining Resistance of Plastics to

(Application for copies are available from www.astm.org or ASTM International, 100 Barr Harbor Drive, West Conshohocken, PA 19428-2959.)

SOCIETY OF AUTOMOTIVE ENGINEERS

SAE-AMS-QQ-A-225	Aluminum Alloy, 2024, Bar, Rod, and Wire; Rolled, Drawn, or Cold Finished
SAE-AS8660	Silicone Compound NATO Code Number S-736

(Copies of these documents are available from www.sae.org or Society of Automotive Engineers, 400 Commonwealth Drive, Warrendale, PA 15096-0001.)

2.3 Order of precedence. In the event of a conflict between the text of this document and the references cited herein, the text of this document takes precedence. Nothing in this document, however, supersedes applicable laws and regulations unless a specific exemption has been obtained.

3. DEFINITIONS

The following definitions of terms used within this standard are intended to provide better application of this standard to all elements of fuzing.

3.1 Alternate test. A method applied to older fuzes designed before adoption of the current standard test (Section 6 of each test).

3.2 Armed. A fuze is considered armed when any firing stimulus can produce fuze function.

- a. A fuze employing explosive train interruption is considered armed when the interrupter(s) position is ineffective in preventing propagation of the explosive train at a rate equal to or exceeding 0.5 percent at a confidence level of 95 percent.
- b. A fuze employing a non-interrupted explosive train is considered armed when the stimulus available for delivery to the initiator equals or exceeds the initiator's maximum no-fire stimulus (MNFS).

3.3 Arming delay. The time elapsed, or distance traveled by the munition, from launch to arming.

3.4 Assembled fuze. The completed fuze with all component parts put together; a fuze requiring no added components or parts to prepare it for installation into the munition in which it is to function. Assembling the fuze is the process of putting the parts and components together.

3.5.1 Booster and lead explosives. Booster and lead explosives are compounds or formulations which are used to transmit and augment the detonation reaction.

3.6 Enabling. The act of removing or activating one or more safety features designed to prevent arming, thus permitting arming to occur subsequently.

3.7 Environment. A specific physical condition to which the fuze may be exposed.

3.8 Explosive ordnance disposal. The detection, identification, field evaluation, rendering safe, recovery and final disposal of unexploded explosive ordnance.

3.9 Explosive train. The detonation or deflagration train (that is, transfer mechanism), beginning with the first explosive element (for example, primer or detonator) and terminating in the main charge (for example, munition functional mechanism, high explosive or pyrotechnic compound).

3.10 Function. A fuze functions when it produces an output capable of initiating a train of fire or detonation in an associated munition.

3.11 Fuze (Fuzing System). A physical system designed to sense a target or respond to one or more prescribed conditions, such as elapsed time, pressure or command, and initiate a train of fire or detonation in a munition. Safety and arming are primary roles performed by a fuze to preclude ignition of the munition before the desired position or time.

3.12 Fuze safety system. The aggregate of devices (for example, environment sensors, launch event sensors, command functioned devices, removable critical items, or logic networks, plus the initiation or explosive train interrupter, if applicable) included in the fuze to prevent arming and functioning of the fuze until a valid launch environment has been sensed and the arming delay has been achieved.

3.13 Independent safety feature. A safety feature is independent if its integrity is not affected by the function or malfunction of other safety features.

3.14 Initiator. A device capable of directly causing functioning of the fuze explosive train.

3.15 Interrupted explosive train. An explosive train in which the explosive path between the primary explosives and the lead and booster (secondary) explosives is functionally separated until arming.

3.16 Invalid test. A test whose procedure has been compromised in a way which renders the results inconclusive. An invalid test is not counted as a failure of the test article.

3.17 Optional test. Additional or more severe criteria not required by the standard test. Optional tests are usually performed during fuze development and intended to determine the margin of safety or reliability in the design (Section 6 of each test).

3.18 Performance. The quantitative measurement of an operational characteristic or range, such as arming time, functioning time, explosive output or leak rate.

3.19 Premature function. A fuze function before completion of the arming delay.

3.20 Primary explosives. Primary explosives are sensitive materials, such as lead azide or lead styphnate, which are used to initiate detonation. They are used in primers or detonators, are sensitive to heat, impact or friction and undergo a rapid reaction upon initiation.

3.21 Reliability. The ability of a fuze to operate or successfully perform all of its functions after exposure to an adverse environment.

3.22 Safety feature. An element or combination of elements that prevents unintentional arming or functioning.

3.23 Standard test. The current, commonly accepted method for evaluating fuze safety, performance or reliability (Sections 1 through 5 of each test).

3.24 Test directive. A formal test plan, procurement specification, or other document which specifies environmental or performance testing in accordance with MIL-STD-331.

3.25 Test parameter. A property which permits variation of the test configuration or procedure. Since selection of test parameters can change the controlled environment or otherwise affect results, each variation must be specified in the test directive.

4. GENERAL REQUIREMENTS

4.1 Test usage. The selection of tests for use shall be made within the application stated in Section 1.5. Tests may be used individually, or in any sequence desired.

4.2 Test compliance. Each individual test shall be performed in the manner specified therein. The standardized structure of each test is described in Section 6.2. The test report shall indicate if a test is not performed as specified and document the differences.

4.3 Selection and specification of tests. A test directive shall be used to invoke the use of each test or sequence of tests described in this standard. Specification of tests shall be made in accordance with 4.8.1 and 5.4.

4.4 Test equipment.

4.4.1 Capability. All equipment required for the test shall provide or meet the conditions required.

4.4.2 Accuracy. The accuracy of instruments and test equipment used to control or monitor the test parameters shall be verified periodically to the satisfaction of the procuring activity. This shall be at least every 12 months, preferably once every 6 months. All instruments and test equipment used in conducting the tests specified herein shall:

- a. Conform to laboratory standards whose calibration is traceable to the U.S. National Institute of Standards and Technology.
- b. Have a measurement error less than one-fourth the tolerance for the variable to be measured. In the event of conflict between this requirement and any accuracy requirement in any one of the tests of this standard, the accuracy requirement of the test being used shall be used.
- c. Be appropriate for measuring the conditions concerned.

4.5 Test conditions. Unless otherwise specified herein, all measurements and tests shall be performed at ambient temperature, pressure, and relative humidity. Whenever these conditions must be controlled in order to obtain reproducible results, a reference temperature of 23°C (73°F), an atmospheric pressure of 760 millimeters of mercury, and a relative humidity of 50 percent shall be used together with whatever tolerances are required to obtain the desired precision of measurement. Actual test conditions shall be recorded during the test period, whether controlled or not.

4.5.1 Installation of test item. Unless otherwise specified, the test item shall be installed, mounted, attached to or placed in the test equipment in a manner that will simulate service use. If fixtures or adapters are required, they shall be designed to provide the same simulation. Plugs, covers, plates, cables, and accessory items used in service shall remain in place. When mechanical or electrical connections on the test item are not used, the connections shall be provided the same amount of protection normally given during service use.

4.5.2 Tolerance of test conditions. The maximum allowable tolerances of test conditions, excluding the accuracy of instruments, unless otherwise specified shall be as follows:

4.5.2.1 Temperature. Plus or minus 2°C (3.6°F).

4.5.2.2 Pressure. When measured by devices such as a manometer, plus or minus 5 percent or 1.3 mm (0.05 in) of mercury, whichever provides the greater accuracy. When measured by devices such as ion gauges, plus or minus 10 percent to 1×10^{-5} torr.

4.5.2.3 Relative humidity. Plus 5 percent, minus 0 percent RH.

4.5.2.4 Vibration amplitude. Sinusoidal, plus or minus 10 percent; random, plus or minus 30 percent.

4.5.3 Preconditioning and stabilization. Unless otherwise specified, no preconditioning or stabilization shall be required. When preconditioning is required, the conditions shall be instituted and brought to the level and for the time specified, at which point the test shall begin. When stabilization is required, the conditions shall be held at the level and for the time specified. Checking operation of or adjusting test equipment with the test item installed or exposed, at any time (pre-test, during test, post-test) shall be kept at a minimum. Such time shall be considered a part of the test time if time is a factor of test item performance or life.

4.6 Examination and test criteria.

4.6.1 Visual examination. At the beginning or completion of any test herein, or when test exposure is considered to have affected the test item, a visual examination shall be made of the item and any damage observed shall be recorded in the test item record. The extent of the visual examination shall be governed by the nature of the test item and the damage suspected or incurred. The examination shall not be performed in a manner which interferes with any subsequent performance or operational test which is necessary to determine conformance with the

criteria for passing the test.

4.6.2 Criteria for passing tests. Fuzes shall be evaluated by standards given in Section 3 of each test at the completion of the procedure. These criteria are determined by the purpose of each test. For performance tests, the criteria are established by the design or procuring agency and are stated in the appropriate test directive. For environmental safety and reliability tests, the criteria are generally characterized by the permissible fuze deterioration or damage sustained during the environmental simulation. Basically, the test item shall remain either safe or both safe and operable during and following the test as described below. Additional criteria further defining or clarifying these standards may be specified in individual tests.

4.6.2.1 Safe. Fuzes usually contain explosive materials and directly affect explosives in the weapon. Therefore, determination of the safety condition of a fuze is vital in establishing its performance adequacy. Usable fuzes shall be safe to handle, transport, store and install. Unusable fuzes shall be safe for disposal consistent with the hazard level of the situation and in accordance with established regulations.

- a. **Safe for use.** The fuze shall maintain its safety features in a condition which will not create a hazard for personnel or cause any subsequent action which will compromise the safety conditions required during handling, transportation, storage and use. Fuze use includes installation and firing or release of the weapon where damage or irregularity does not prevent assembly of the fuze to the weapon or loading.
- b. **Safe for disposal.** If the fuze is unusable, it shall maintain its safety features, including Explosive Ordnance Disposal (EOD) features, in a condition which will permit its disposal without injury to personnel using the applicable handling and disposal regulations and procedures.

4.6.2.2 Operable. When the fuze is provided its required inputs, it shall perform to completion of its function and sequence producing all required outputs within the operating period or at the specified time. Determination of operability may require firing the fuze using a procedure adapted to the type of fuze being tested and its associated munition.

4.7 Safety condition. When the test item contains explosive material or components, safety procedures and equipment consistent with the hazard level shall be used to ensure adequate protection for personnel and equipment in case of an explosion.

4.8 Test documentation. A complete record of test conduct, conditions, data, and so forth shall be kept to provide a proper analysis of the technical effort and results. Formal reporting shall be done only as required by the contract or work assignment. To assure a proper record, the following major items of the test effort shall be documented for any test performed. This listing is general in nature and is applicable to all tests of the standard. Individual tests may call out additional data items.

4.8.1 Test directive. The test directive, is used to invoke standard tests and provide all necessary details as to their conduct. The test directive may be incorporated into a procurement

specification or prepared as a separate development test plan and shall include:

- a. the test number and title,
- b. the quantity of fuzes to be tested,
- c. the test sequence,
- d. inspections, measurements, data gathering and data analysis methods to be performed,
- e. modifications or waivers of standard test requirements (refer to 4.2),
- f. applicable alternate tests, optional tests or parameters (refer to 5.4), and
- g. procedures to verify fuze operation following completion of each test.

4.8.2 Test item record. A test item record is used to document the identity, features, condition and performance of the test article before, during and after each test or test sequence.

4.8.2.1 Condition before test. Prior to conducting the tests, the condition of each test item shall be established by methods such as visual inspection, X-rays, leak test or special performance tests. The following shall be recorded:

- a. serial number or other identifier,
- b. unique identifying characteristics,
- c. missing components,
- d. presence or absence of explosive components,
- e. modifications to facilitate testing or instrumentation, and
- f. if required, the performance level shall be established using appropriate tests identified by the test directive and a record made of compliance with performance specifications.

4.8.2.2 Condition during test. Significant observations of the test article or instrumentation shall be recorded. If the test article must be operated during the test, a record shall be kept of the data for comparison with pre-test or post-test performance.

4.8.2.3 Condition after test. Following the environmental test:

- a. Applicable procedures such as breakdown, visual inspection, X-ray or leak test shall be performed and the observations or results recorded.
- b. If test article performance must be demonstrated, the record shall include a description of each operational test performed, its specification and relative performance of the test article.
- c. Analysis, conclusions (pass/fail determination), and any corrective action shall be recorded based on the results of post-test examination and performance tests, a. and b., above.

4.8.3 Test equipment. A listing of all equipment used during the test effort as described in Section 4.4, Test equipment.

4.8.4 Test conditions. The conditions of test, as applicable to the test requirements, as described in 4.5, Test conditions.

4.8.5 Test results. The test data analysis and the technical conclusions made from the data analysis. The data analysis may be represented by examples, dependent upon the nature and extent of the data to be analyzed and the methods used. Any deviations or waivers on the original test plan or the procedures of the standard shall be documented, along with the technical reasons for the changes.

5. DETAILED REQUIREMENTS

5.1 Individual tests. Detailed requirements are specified in individual tests appearing as appendices to this standard. The format for each test is standardized and is explained in Section 6.2, below. Each test is composed of seven sections. Sections 1 through 5 are mandatory for compliance with MIL-STD-331. Alternate procedures which may be applicable to older fuzes and optional procedures which are recommended for further testing are contained in Section 6 of the individual test. Section 7 of each test contains background or additional sources of information and is not necessary for compliance.

5.2 Test classification. Tests are grouped by the environment to which the fuze is exposed or by the test purpose. Certain tests combine two or more environments; for example, vibration under exposure to extreme temperature. In these cases the test is grouped by the primary environment being evaluated.

5.2.1 Group A - Mechanical Shock Tests. Fuzes are subjected to single or repeated impacts which generally simulate mishandling that might occur during the logistical or operational cycles.

5.2.2 Group B - Vibration Tests. Fuzes are subjected to vibrations of specified frequency, amplitude and duration simulating conditions which are anticipated during transport or tactical use.

5.2.3 Group C - Climatic Test. Fuzes are exposed to realistic extreme climatic conditions for specified periods of time.

5.2.4 Group D - Safety, Arming and Functioning Tests. These tests measure performance characteristics of fuzes, such as, explosive safety, arming distance or time and output.

5.2.5 Group E - Aircraft Munition Tests. Fuzes associated with airborne munitions are subjected to impacts or forces which might be encountered in takeoff and landing, accidental separation of the munition from the aircraft, or intentional safe jettison.

5.2.6 Group F - Electric and Magnetic Influence Tests. Fuzes are subjected to environments such as electrostatic discharge (ESD), electromagnetic pulse (EMP), electromagnetic radiation (EMR), lightning, and so forth.

5.3 Test number conversion. Previous editions of this standard used a three digit numeric to identify each test. Where existing product specifications refer to these test numbers, refer to Table I to find the current test.

5.4 Invoking tests. In addition to the requirements of 4.8.1, the test directive shall specify applicable alternate or optional tests, as well as various test parameters described in this standard. These are identified in Table II.

5.4.1 Alternate and optional tests. Alternate tests apply to older fuzes developed prior to adoption of the current standard test (Sections 1 through 5 of each test). Optional tests may be specified to determine the safety or reliability design margin during fuze development. Alternate and optional test procedures are described in Section 6 of each test.

5.4.2 Test parameters. Many tests contained in this standard may be performed in various ways, depending on the fuze design or other factors. Some variations change the controlled environment or affect the results of the test. As a minimum, the test directive shall identify the required variation for each parameter listed in Table II. In addition, each test should be reviewed to determine if further clarification is necessary. Additional detail is recommended for:

- a. explosive loading of the test article and associated munition,
- b. modification of the test article, and
- c. specifications for test fixtures.

6. NOTES

(This section contains information of a general or explanatory nature that may be helpful, but is not mandatory.)

6.1 Background information. The tests contained in this standard have been developed over a period of years by designers and users of fuzes. Although they were developed based on functional aspects unique to fuzes, many of the tests have been specified in the development and procurement of other ordnance components and test equipment. Application of many tests appears to be limited only by the physical capacity of the test facilities; however, careful consideration should be given to various aspects of these tests before they are specified.

6.1.1 Safety. The first aspect is the requirement of safety, due to the direct presence of explosives in the fuze or in the concomitant effect of the fuze on associated explosives in the operational sequence of the weapon. The tests must reflect complete safety in test conduct, as well as establish that the fuze design achieves the safety attributes which are required for service use.

6.1.2 Short operational time. The second functional aspect is the short operational time of a fuze in relation to the comparatively longer operational time and service life of the complete weapon. Each test must be devised to provide the full extraction of information on fuze performance under such restrictive operational conditions.

6.1.3 One-time operation. The third functional aspect is the one-time life of a fuze, a condition which is coincident with the previously stated aspect of short operational time. The one-time performance tests in many instances cause destruction of the test item or components of the

test item, thus restricting subsequent analysis. The test design must anticipate and provide for the maximum return of information under such conditions.

6.2 Test content and format. Each test is prepared in a standardized format divided into seven sections: purpose, description, criteria for passing test, equipment, procedure, alternate or optional tests, and related information. The first five sections contain all essential information for setting up and conducting the test and are mandatory for compliance with this standard. Alternate or optional tests in Section 6 may be specified by the test directive. Related information is not mandatory; it is intended to provide background to the test. The content of each test section is described below.

6.2.1 Purpose. The purpose of each test must contain the following information:

6.2.1.1 Location. The test must be identified as a laboratory test or field test.

6.2.1.2 Safety, reliability or performance. Tests which determine if the fuze is safe for use or disposal must be identified as safety tests. If fuze arming or functioning is required either by procedures within the test or by conducting a separate test, the test must be regarded as a reliability test. If the test quantitatively measures the operational parameters of the fuze, it must be identified as a performance test.

6.2.1.3 Life cycle phase. Identify the fuze life cycle phase which is the subject of the test. These include storage, handling, transportation, preparation for use or any combination of these.

6.2.1.4 Environment or performance measurement. State the specific conditions of the test such as exposure to extreme temperature, vibration, and so forth, the performance characteristic being measured such as arming distance.

6.2.2 Description.

6.2.2.1 General. This is a general description of the test procedure, expanding on the purpose stated above.

6.2.2.2 Fuze configuration. State the physical configuration of the fuze during testing, whether or not explosive components are installed, whether or not the fuze is packaged, or whether the fuze is installed in a live or inert munition or munition simulator.

6.2.2.3 Variations. Description of any variations in test configuration, procedure, or criteria for passing the test. A statement is included that appropriate variations will be selected in the test directive when the test is invoked.

6.2.2.4 Applicable publications. A standardized statement identifying other publications forming a part of this test. Complete bibliographical references are contained in the basic standard.

"All standards, specifications, drawings, procedures and manuals which form a part of this test are listed in Section 2 of the introduction to this standard. Special attention is directed to (listing of any

unique requirements)."

6.2.2.5 Test documentation. A reference to the introduction of the standard containing general requirements for documentation of all tests. Unique documentation is identified within the test.

"Test plans, performance records, equipment, conditions, results and analysis must be documented in accordance with 4.8 of the general requirements to this standard."

6.2.3 Criteria for passing test. For most performance tests, the criteria for passing the test must be stated in the development test plan or production specification. For safety and reliability tests, the following standardized statements must be applied.

6.2.3.1 Fuze condition. List one of three standardized statements identifying the condition of the fuze following the test.

"At the completion of this test, the fuze must be safe for transportation, handling and use, as well as operable in accordance with 4.6.2.1a and 4.6.2.2 of the general requirements to this standard."

"At the completion of this test, the fuze must be safe for transportation, storage, handling and use in accordance with 4.6.2.1a of the general requirements to this standard. The fuze does not have to be operable."

"At the completion of this test, the fuze must be safe for disposal in accordance with 4.6.2.1b of the general requirements to this standard."

6.2.3.2 Decision basis. The following statement is applied.

"Breakdown, inspection, other appropriate tests and engineering judgment will form the basis for the decision that fuzes have passed or failed the test."

6.2.4 Equipment. This section contains specifications for all support equipment necessary to conduct the test.

6.2.5 Procedure. This is the step-by-step procedure for conducting the test.

6.2.6 Alternate and optional tests. This section may contain alternate procedures or equipment specified prior to issuance of the current information contained in sections 1 through 5 of the test. Alternate procedures may apply to older fuze designs for which the current test requirements are not intended. In addition, optional test requirements may be specified in this section. These include more severe conditions, such as longer test duration, higher temperatures, and so forth. Optional tests are typically performed during fuze development to determine the margin of safety or physical limitations of the design. If required, compliance with this section of the test will be stated in the test directive.

6.2.7 Related information. This section may include the rationale or background

information for any particular aspect of the test. This section may also contain a bibliography referring to background information in other publications. It may not contain references to documents such as standards and specifications which form a part of the test. Complete references to these documents are contained in Section 2 of the introduction to the standard and may be referenced by number in Section 2 of each test. Material contained in this section is not mandatory.

6.2.8 Illustrations and tables. Illustrations and tables requiring a full page will normally appear after the last page of text.

6.3 Units of measure. Units of measure are expressed in metric or SI (Système International d'Unités) wherever applicable. The corresponding English equivalent normally follows in parentheses. Standard abbreviations commonly used throughout this document are as follows:

<u>Metric (SI)</u>	<u>English</u>
mm - millimeters	in - inches
m - meters	ft - feet
km - kilometers	mi - miles
mg - milligrams	oz - ounces
g - grams	
kg - kilograms	lb - pounds
l - liter	cu ft - cubic feet
°C - degrees Celsius	°F - degrees Fahrenheit
MPa - MegaPascal (gage)	psig - pounds/square inch (gage)
cal - calorie	BTU - British Thermal Unit
cc - cubic centimeter	
ml - milliliter	
<u>Standard</u>	<u>Other</u>
hr - hours	kn - knots
s - seconds	rpm - revolutions per minute
min - minute	rps - revolutions per second
g - gravity units	
o - degrees	

Standard caliber sizes or other units of measure normally specified in English or metric have not been converted. Examples include 5-in or 76-mm guns and pressure expressed in millimeters of mercury.

6.4 Test characteristics. Table III provides a summary of test characteristics for MIL-STD-331. These include the purpose of the tests, environments investigated, criteria for passing the tests, configuration of the fuze or fuzed munition, location, and whether or not the test is normally performed during development or production.

6.5 Subject term (key word) listing.

Aircraft munitions

Arming

Climatic

Drop

Electric influence

Functioning

Jolt

Jumble

Magnetic influence

Safety

Shock

Transportation

Vibration

6.6 Changes from previous issue. The margins of this standard are marked with vertical lines to indicate where changes from the previous issue were made. This was done as a convenience only and the Government assumes no liability whatsoever for any inaccuracies in these notations. Bidders and contractors are cautioned to evaluate the requirements of this document based on the entire content irrespective of the marginal notations and relationship to the last previous issue.

6.7 Useful references. MIL-Q-9858, *Quality Program Requirements* (canceled).

MIL-STD-331C
w/CHANGE 1

TABLE I. Test Number Conversion

If specification references the test indicated below, ...	then use sections 1 thru 5 of the test indicated below unless otherwise specified.	If specification references the test indicated below, ...	then use sections 1 thru 5 of the test indicated below unless otherwise specified.
101.3	A1	120 or 403	B1.1, Section B1.6.5
102.2	A2.1	121	Deleted
103.2	A3	122	B3
104 or 401	B1.1, Section B1.6.3	123	B1.1, Section B1.6.2
105.1	C1	124	B1.1, Section B1.6.2
106.1	C2	125.1	A5
107.1	C3	126	F1.2
108	C4	201 thru 205	E1
109.1	Deleted	206	E2
110.1	C5	207	D2, Section 5.2
111.1	A4.1	208.2	D2
112.1	C6	209	E3
113.1	C7	210.1	D3
114 or 402	B1.1, Section B1.6.4	211 or 406	Deleted (Replaced by U.S. Army TOP 7-2-506 and 509)
115.3	D1		
116.1	C9	212	E4
117	E5	213 or 405	Deleted (Replace by U.S. Army TOP 7-2-506 and 509)
118	C8		
119 or 404	B1.1, Section B1.6.2	301 thru 303	D4

TABLE II. Test Parameters

Test	Specification		
	Parameter	Variable	Para.
A1 Jolt	Test fixture	a. Government jolt machine b. Commercial shock machine	A1.4.1 A1.4.2
	Optional tests	a. Subject fuzes to two cycles b. Perform test until fuze fails	A1.6
A2.1 Jumble		No variations	
A3 Twelve-meter (40 foot) Drop	Test article configuration	a. Unpackaged, fuzed munition b. Packaged, fuzed munition c. Packaged fuze 1. All explosive loaded fuzes 2. Dummy fuzes at interior package positions	A3.2.2
	Booster	a. Explosive loaded b. Inert	A3.5.2.1
	Pass/fail criteria	a. No detonation permitted b. Detonator may fire	A3.3.2
	Temperature	a. Ambient only b. Ambient and extreme (specify)	A3.5.3
	Optional test	Different test height	A3.6
A4.1 One and One-half Meter (five foot) Drop	Procedure	a. Two-drop schedule b. One-drop schedule	A4.2.1
	Test article configuration	a. Unpackaged, fuzed munition b. Unpackaged fuze c. Both a. and b. if shipped both ways	A4.2.3
	Booster	a. Explosive loaded b. Inert	A4.2.2
	Pass/fail criteria	a. Safe for use b. Safe for use and operable	A4.3.1
	Optional tests*	a. Extreme temperature b. Different impact surfaces c. Larger drop height d. Alternately disabled safety features	A4.6
A5 Trans-portion Handling (Packaged Fuzes)	Test article configuration	a. Complete fuzes in package 1. All explosive loaded fuzes 2. Dummy fuzes at interior package positions b. Packaged, fuzed, explosive loaded munition c. Packaged, fuzed, inert munition	A5.2.2
	Temperature	Specify optional temperatures	A5.2.4.1

MIL-STD-331C
w/CHANGE 1

	Pass/fail criteria	Define acceptable minor damage	A5.2.4.2
	Alternate tests	a. Specification for fuzes developed before 18 May 82 apply. b. Specifications for Army fuzes developed between 15 Oct 76 and 18 May 82 apply.	A5.6
B1.1 Transportation Vibration (Bare and Packaged Fuzes)	Test article configuration	a. Complete bare fuzes b. Bare, fuzed, inert munition c. Complete, packaged fuzes	B1.2.3
	Transportation conveyance scenario	Commercial vehicle, military vehicle, jet aircraft, turboprop aircraft, helicopter, cargo ship, combat ship, or unspecified.	B1.2.2.1
	Alternate tests	a. Bare and packaged fuzes designed between 5/18/82 and 1/1/97; bare fuzes designed between 11/1/73 and 5/18/82	B1.6.2
		b. Bare fuzes designed before 11/1/73	B1.6.3
		c. Packaged fuzes designed before 5/18/82	B1.6.4
		d. Packaged fuzes designed between 10/15/76 and 5/18/82 (Army only)	B1.6.5
B3 Tactical Vibration	Applicable procedure	a. Air-launched munition b. Ground-launched munition c. Ship-launched munition d. Underwater-launched munition	B3.2.1
	Booster & lead	a. Explosive loaded b. Inert	B3.2.2
C1 Temperature and Humidity		No variations	
C2 Vacuum-Steam-Pressure		No variations	
C3 Salt Fog	Test duration	a. 48 hours b. 96 hours	C3.2.1, C3.6.1
C4 Water-proofness	Test article configuration	With or without explosive components	C4.2.2
C5 Fungus	Optional test	Additional fungi types (specify)	C5.6
C6 Extreme Temperature	Temperature	a. Extreme low and high b. Extreme low c. Extreme high	C6.2.1
C7 Thermal Shock		No variations	

MIL-STD-331C
w/CHANGE 1

C8 Leak Detection	Pass/fail criteria	Specify leak rate	C8.3
	Test method	a. Halogen gas method b. Helium gas method c. Bubble method d. Volume-sharing method	C8.5
	Alternate test	Lower pressure	C8.6
C9 Dust		No variations	
C10 Solar Radiation	Method	a. Solar radiation and heat cycling b. Solar radiation only	C10.2.1
	Test article configuration	a. Unpackaged, fuze munition b. Fuzed munition c. Packaged fuzes	C10.2.2
	Booster & lead	a. Explosive loaded b. Inert	C10.2.3
D1 Primary Explosive Component Safety	Test fixture	As appropriate **	D1.4.1
	Fragmentation box	As appropriate **	D1.4.2
	Firing mechanism	As appropriate **	D1.4.3
	Test article configuration	As appropriate **	D1.4.4
	Fuze modification	As appropriate **	D1.5.1
	Worst case simulation	Sequential or simultaneous initiation of explosive components **	D1.5.2
	Optional tests *	a. Possible failure paths b. Progressive arming c. Barrier thickness d. Increased output e. Increased sensitivity f. Cookoff	D1.6.2 D1.6.3 D1.6.4 D1.6.5 D1.6.6 D1.6.7 & D1.6.8
D2 Projectile Fuze Arming Distance	Munition	a. Explosive loaded b. Inert round c. Spotting charge	D2.2.2
	Test method	a. Probit b. Langlie c. Weibull one-shot transformed response (OSTR) d. Bruceton	D2.5.1
	Optional test	Muzzle arming	D2.5.2

MIL-STD-331C
w/CHANGE 1

D3 Time to Air Burst	Pass/fail criteria	Must be specified in test directive	D3.3.1
	Test weapon	As appropriate	D3.4.1
	Munition	a. Explosive loaded b. Inert with spotting charge	D3.4.2
	Temperature	a. Ambient b. Must be specified in test directive	D3.5.3
D4 Explosive Component Output	Test method	a. Dent block b. Disc perforation	D4.2.1.1 D4.2.1.2
	Pass/fail criteria	Must be specified in test directive	D4.3
	Initiation device	As appropriate **	D4.4.1
	Witness device	As appropriate **	D4.4.2 & D4.4.3
	Test fixture	As appropriate **	D4.4.4
	Measuring device	As appropriate **	D4.4.5
D5 Rain Impact	Temperature	Any other than ambient must be specified in test directive	D5.2.5
	Target	Must be specified in test directive	D5.2.9
	Optional test	Increased test article velocity	D5.6
D6 Brush Impact no-Fire Test	Temperature Intercept conditions	Ambient unless otherwise specified in test plan The intended incept conditions must be specified in the test plan	D6.2.3 D6.2.8.1
D7 Mortar Ammunition Fuze Double Loading Test	Temperature	Ambient unless otherwise specified in test plan	D7.5.4
D8 Progressive Arming Test	Test methodology	Will be consistent with those given in section D2.5 of test method D2	D8.5.1
E1 Jettison	Test method	a. Air drop b. Ground launcher	E1.2.1.1 E1.2.1.2
	Test article configuration	Use of a scavenger fuze	E1.4.2
	Target	a. Soil b. Water c. Sand	E1.4.3.1 E1.4.3.2 E1.4.3.3
	Instrumentation	Must be specified in test directive	E1.4.4
E2 Low-altitude Accidental		No variations	

MIL-STD-331C
w/CHANGE 1

Release			
E3 Arrested Landing Munition Pull-off		No variations	
E4 Catapult and Arrested Landing Forces		No variations	
E5 Simulated Parachute Air Delivery	Optional tests *	a. System without energy absorbers b. High-velocity test	E5.6.1 E5.6.2
F1.1 Electro-static Discharge (ESD)	Lead & Booster	a. Explosive loaded b. Inert	F1.2.4
	Location of discharge points	Must be specified in test directive	F1.2.6
	Number of discharges per fuze	Must be specified in test directive	F1.2.6
	Type of electrode control	Must be specified in test directive	F1.2.6
	Discharge gap	Must be specified in test directive	F1.2.6
	Test sequence	Must be specified in test directive	F1.2.6
F2.1 High-altitude Electromag-netic Pulse	Test article configuration	a. Lead and booster b. Inert munition c. Standard fuze package	F2.2.2
	Number of test items	a. Instrumented (one item per test mode) b. Uninstrumented (ten items per test mode)	F.2.2.4
	Optional tests	Tactical conditions	F2.6
F3.1 Electro-magnetic Radiation Hazards (HERO)	Test article configuration	Lead and booster	F3.2.3
F4.1 Electro-magnetic Radiation Opera- tional (EMRO)	Test article configuration	Lead and booster	F4.2.3

* Select as many as apply.

** Although some guidance is given, specific detail should be contained in the test directive

TABLE III. Test Characteristics

Group	Test	Purpose	Environment	Criteria for Passing Test	Munition	Packaged	Location	Use
Mechanical Shock	A1 Jolt	S	T	Safe for use ¹	None	No	Lab	D,P
	A2.1 Jumble	S	T	Safe for use ¹	None	No	Lab	D,P
	A3 12-m Drop	S	H	Safe for disposal	None,I,L	2	3	D,P
	A4.1 1.5-m Drop	S,R,P	H,U	Safe for use ⁴	None,I,L	No	3	D,P
	A5 Transportation Handling	S,R,P	H,U	Operable	None,I,L	Yes	Lab	D,P
Vibration	B1.1 Transportation Vibration	S,R	T	Operable	None	2	Lab	D,P
	B3 Tactical Vibration	S,R	U	Operable	None	No	Lab	D,P
Climatic	C1 Temperature & Humidity	S,R	S	Operable	None	No	Lab	D,P
	C2 Vacuum-Steam-Pressure	S,R	S	Operable	None	No	Lab	D
	C3 Salt Fog	S,R	S	Operable ⁵	None	No	Lab	D
	C4 Waterproofness	S,R	S,H	Operable ⁶	None	No	Lab	D,P
	C5 Fungus	S,R	S	Operable	None	No	Lab	D
	C6 Extreme Temperature	S,R	S	Operable	None	No	Lab	D,P
	C7 Thermal Shock	S,R	S	Operable	None	No	Lab	D,P
	C8 Leak Detection	P	S	7	None	No	Lab	D,P

MIL-STD-331C
w/CHANGE 1

	C9 Dust	S,R	S,H,U	Operable ⁸	None	No	Lab	D
	C10 Solar Radiation	S,R	S	Operable	None,I	2	Lab	D
Safety, Arming & Functioning	D1 Primary Explosive Component Safety	S	S,H,T,U	9	None	No	Lab	D,P
	D2 Projectile Fuze Arming Distance	S,P	U	7,10	I,L	No	Field	D,P
	D3 Time to Air Burst	P	U	7	I,L	No	Field	D,P
	D4 Explosive Component Output	P	U	7	None	No	Lab	D,P
	D5 Rain Impact	S,P	U	11	I	No	Field	D
	D6 Brush Impact No-Fire Test	S,P	U	Safe, Operable	I	No	Field	D
	D7 Mortar Ammunition Fuze Double Loading Test	S	H,U	Safe	I	No	Field	D
	D8 Progressive Arming Test	S	S,H,T,U	1	None	No	Lab	D
Aircraft Munition	E1 Jettison	S	U	Safe for disposal ¹²	L	No	Field	D
	E2 Low Altitude Accidental Release	S	U	Safe for disposal ¹²	L	No	Field	D
	E3 Arrested Landing Pull-off	S	U	Safe for disposal ¹²	L	No	Field	D
	E4 Catapult & Arrested Landing Forces	S,R	U	Operable	I	No	Field	D
	E5 Simulated Parachute Air Delivery	S,R	H,T,U	Operable ¹³	None,I	Yes	Field	D
Electric & Magnetic Influence	F1.1 Electrostatic Discharge	S,R	H,T,U	Safe for use ¹⁴	None	2	Lab	D,P
	F2.1 Electromagnetic Pulse	S,R	S,H,T,U	Operable ⁷	I	No	Lab	D

MIL-STD-331C
w/CHANGE 1

F3.1 EMR Hazards (HERO)	S,R	S,H,T,U	Operable	None	2	Lab	D
F4.1 EMR, Operational (EMRO)	S,R	S,H,T,U	Operable	None	No	Lab	D

Legend: Purpose S = safety; R = reliability; P = performance.
Environment: S = storage; T = transportation; H = handling; U = use.
Munition: None = test conducted without munition; I = inert round or spotting charge;
L = live round.
Use: D = development; P = production.

- Notes:
1. No detonation of explosive components.
 2. Test contains requirements for both bare and packaged fuzes.
 3. Drop facility may be located in a laboratory or at an outdoor field test site.
 4. Test directive may optionally specify that the fuze be operable.
 5. The fuze is not required to operate after a 96-hour test.
 6. No evidence that water has entered fuze.
 7. Specified in the test directive.
 8. Inspection ports and labels must be clear when dust is wiped away.
 9. No detonation beyond interrupter. No ejection of parts. No other hazards.
 10. In muzzle safety test, no detonation permitted beyond last safety device.
 11. Fuze functions on target, not in rain field.
 12. No detonation of warhead attributed to fuze.
 13. At completion of the malfunctioning test, the fuze must be safe for disposal.
 14. Fuze must also be operable after human body discharge and air replenishment discharge (packaged) tests.

MIL-STD-331C
W/CHANGE 1
APPENDIX A

APPENDIX A
MECHANICAL SHOCK TESTS

TEST A1

JOLT

A1.1 PURPOSE

This is a laboratory safety test simulating ground transportation conditions. The fuze must withstand a series of impacts applied in a controlled direction and amplitude.

A1.2 DESCRIPTION

A1.2.1 General. Fuzes are subjected to 1750 impacts in three orientations: major axis horizontal and major axis vertical both nose up and nose down.

A1.2.1.1 Jolt machine method. This method shall be used for fuzes and any required mounting adapters having a combined weight of 3.6 kg (8 lb) or less and having a configuration permitting simultaneous testing of three fuzes on one jolt arm. If fewer than three fuzes are to be tested, dummy loads, equivalent in mass to the test fuze and fixture, shall be assembled to the unused jolt arm sockets.

A1.2.1.2 Commercial shock machine method. This method shall be used for fuzes and any required mounting adapters having a combined weight of more than 3.6 kg (8 lb) or having a configuration which does not permit simultaneous mounting and testing on one arm of the jolt machine.

A1.2.2 Fuze Configuration. Only bare, unpackaged fuzes shall be used in this test. Each fuze shall be completely assembled, containing all explosive elements which are a part of the fuze design.

A1.2.3 Applicable publications. All standards, specifications, drawings, procedures and manuals which form a part of this test are listed in Section 2 of the introduction to this standard. Special attention is directed to Dept. of the Army Ordnance Corps Drawing 9 255 299 for the jolt machine.

A1.2.4 Test documentation. Test plans, performance records, equipment, conditions, results and analysis shall be documented in accordance with Section 4.8 of the general requirements to this standard.

A1.3. CRITERIA FOR PASSING TEST

A1.3.1 Fuze condition. At the completion of this test, the fuze shall be safe for transportation, storage, handling and use in accordance with 4.6.2.1a of the general requirements to this standard. No explosive component shall have initiated. The fuze does not have to be operable.

A1.3.2 Loose fuzes. A test is invalid if the fuze or any required mounting adapter becomes loose while the machine is operating.

A1.3.3 Decision basis. Breakdown, inspection, other appropriate tests and engineering judgment shall form the basis for the decision that fuzes have passed or failed the test.

A1.4. EQUIPMENT

A1.4.1 Jolt machine method. Equipment for this method shall conform to Department of the Army, Ordnance Corps Drawing 9 255 299. The equipment consists of a jolt machine, shown

MIL-STD-331C
w/CHANGE 1
APPENDIX A

in Figure A1-1, either mounted on a base of welded steel plate or set in a concrete foundation. Its four arms are pivoted side by side on a common shaft. The free ends of the arms are alternately elevated to a height of 102 mm (4 in) by cam action and then allowed to fall freely on a padded anvil. The cams are adjusted on the cam shaft so that only one arm at a time is jolted.

A1.4.1.1 Sockets and adapters or fixtures. The free end of each arm is provided with three threaded sockets (2-in-12UN-1B thread), located so that fuzes can be jolted in the three different orientations as specified in A1.2.1. Usually, the manner in which each fuze is assembled to the socket shall depend on the design of the munition in which the fuze is to be used. In most cases, it is only necessary to thread the test fuzes directly into the sockets. In other cases, special adapters or fixtures may be required. Unique fuze-to-munition mounting requirements should be duplicated in this test.

A1.4.1.2 Shock parameters. Although the basic impact pattern imparted to the test fuze by the jolt machine is largely fixed by the machine's design, the two adjustable parameters shall be set as follows:

- a. Jolt arm drop height of 102 ± 5 mm (4 ± 0.2 in).
- b. Pulse rate of 35 ± 5 impacts per minute.

A1.4.2 Commercial shock machine. A commercial shock machine may be used if it can impart the characteristic shocks specified in A1.5.2.1 to larger fuzes which cannot be tested with the jolt machine. It shall be possible for the shock machine to test the fuze in any one of the three orientations specified in A1.2.1. Requirements covering mounting sockets, adapters, or duplication, shall be as in A1.4.1.1 for the jolt machine.

A1.5. PROCEDURE

A1.5.1 Jolt machine method.

A1.5.1.1 Inspection of equipment. Verify that the equipment is in good operating condition.

- a. The drop height of each arm is calibrated by a gage to 102 ± 5 mm (4 ± 0.2 in).
- b. The arms are structurally sound, that is, there is no evidence of breaks or cracks.
- c. All screw and bolt connections are tight.
- d. The pad is in good working order; that is, it has no tears, no missing pieces, and is not brittle.
- e. The machine, including the fuze sockets, is electrically grounded.

A1.5.1.2 Mount fuzes to jolt arms. Mount a fuze in each of three orientations of each jolt arm used. If the number of fuzes available for testing is less than three per active arm, dummy loads as specified in A1.2.1.1 shall be used to make up the difference. When tested in the horizontal position, the fuze shall be rotationally oriented to receive the jolts on its critical plane of weakness, if known. Fuzes assembled to the sockets shall be tightened using torque values appropriate for the type of fuze being tested, or as specified in the test directive or product specification.

A1.5.1.3 Operate machine. Operate the machine through 1750 ± 10 drops.

A1.5.1.4 Interim removal. The fuzes shall be removed from the sockets and inspected for any degradation that would affect their performance or safety, without further fuze disassembly.

A1.5.1.5 Test at other orientations. Repeat the above three steps twice so that at the conclusion of the test each fuze shall have received 1750 jolts in each of the three test orientations.

A1.5.1.6 Compliance. Remove the fuzes from the machine. Analyze the test results and determine whether or not the test article meets the pass/fail criteria in Section A1.3. Continue testing the specified number of items.

A1.5.2 Commercial shock machine method.

A1.5.2.1 Calibration of machine. Prior to use, calibrate the machine with an equivalent test load to ensure that the fuze shall be subjected to a half-sine wave pulse, shown in Figure A1-2, having 230 ± 34.5 g peak acceleration for 2.0 ± 0.2 milliseconds duration. The pulse rate for the jolt machine is 35 ± 5 impacts per minute.

A1.5.2.2 Mount fuze to shock table. Rigidly attach the fuze to the shock table in any of three test orientations by the method which the fuze is normally attached to its munition. Torque shall be appropriate for the type of fuze being tested, or as specified in the test directive or product specification. When tested in the horizontal position, the fuze shall be rotationally oriented to receive the shocks on its critical plane of weakness, if known.

A1.5.2.3 Operate machine. Shock the fuze 1750 ± 10 times in the initial orientation.

A1.5.2.4 Interim removal. Remove the fuze from shock table and inspect fuze without further fuze disassembly.

A1.5.2.5 Test at other orientations. Repeat the above three steps twice, so that at the conclusion of the test, the fuze shall have received 1750 shocks in each of the three test orientations. Initial shock positions for the other test fuzes shall be rotated among the three given positions: horizontal, nose up, and nose down.

A1.5.2.6 Compliance. Remove the fuzes from the machine. Analyze the test results and determine whether or not the test article meets the pass/fail criteria in Section A1.3. Continue testing the specified number of items.

A1.6 ALTERNATE AND OPTIONAL TESTS

Additional fuzes may be subjected to two cycles of 1750 jolts in each of the three positions, or until evidence is obtained that the fuzes have failed, whichever occurs first. The test may also be performed with each safety feature alternately disabled to demonstrate the ability of the remaining safety features to provide independent safety.

A1.7 RELATED INFORMATION

A1.7.1 Jolt test background. The jolt test has been used for many years to establish the safety and general ruggedness of fuze designs under severe conditions of transportation. Transport vehicles have changed in nature since the test was first devised; however, the rough environment of transportation is considered to be essentially the same. This test therefore continues to be used as a safety and ruggedness test of fuze designs.

A1.7.2 Limitations, jolt machine. When the jolt machine was designed, it was intended for projectile fuzes which could be either mounted directly to the sockets or readily adapted to fit the sockets. As new and larger bomb and missile fuzes of various geometric configurations evolved, the jolt machine was still used as a test platform, though the fixturing was often very complex. It is recognized by test engineers that the jolt machine is not appropriate for some test items.

A1.7.3 Commercial machine and material substitution. The revision of 15 October 1976 introduced a method using commercial shock machines to test larger fuzes. Also permitted by that revision, were material substitutions of cast nylon in place of wood for the jolt arms and polyurethane in lieu of leather for the shock pads. The changes were intended to achieve more uniform testing, facilitate procurement, and to provide longer life for these components without significantly changing the jolt environment. Mixed substitution of components shall not be allowed as it could result in an entirely different jolt test environment.

A1.7.4 Monitoring basis. Although the jolt machine is a qualitative type of testing tool, its

MIL-STD-331C
w/CHANGE 1
APPENDIX A

calibration is defined quantitatively in terms of the drop height, number of drops, and drops per minute. The shock spectrum signature derived may be used to monitor the stability of operation and to compare the operating characteristics of different machines.

A1.7.5 Bibliography.

Frankford Arsenal Technical Report 75077, *Improvements to Fuze Test Methods and Development of New Monitoring Techniques*, National Technical Information Service (NTIS) No. AD-A024032, 5285 Port Royal Road, Springfield, VA 22161.

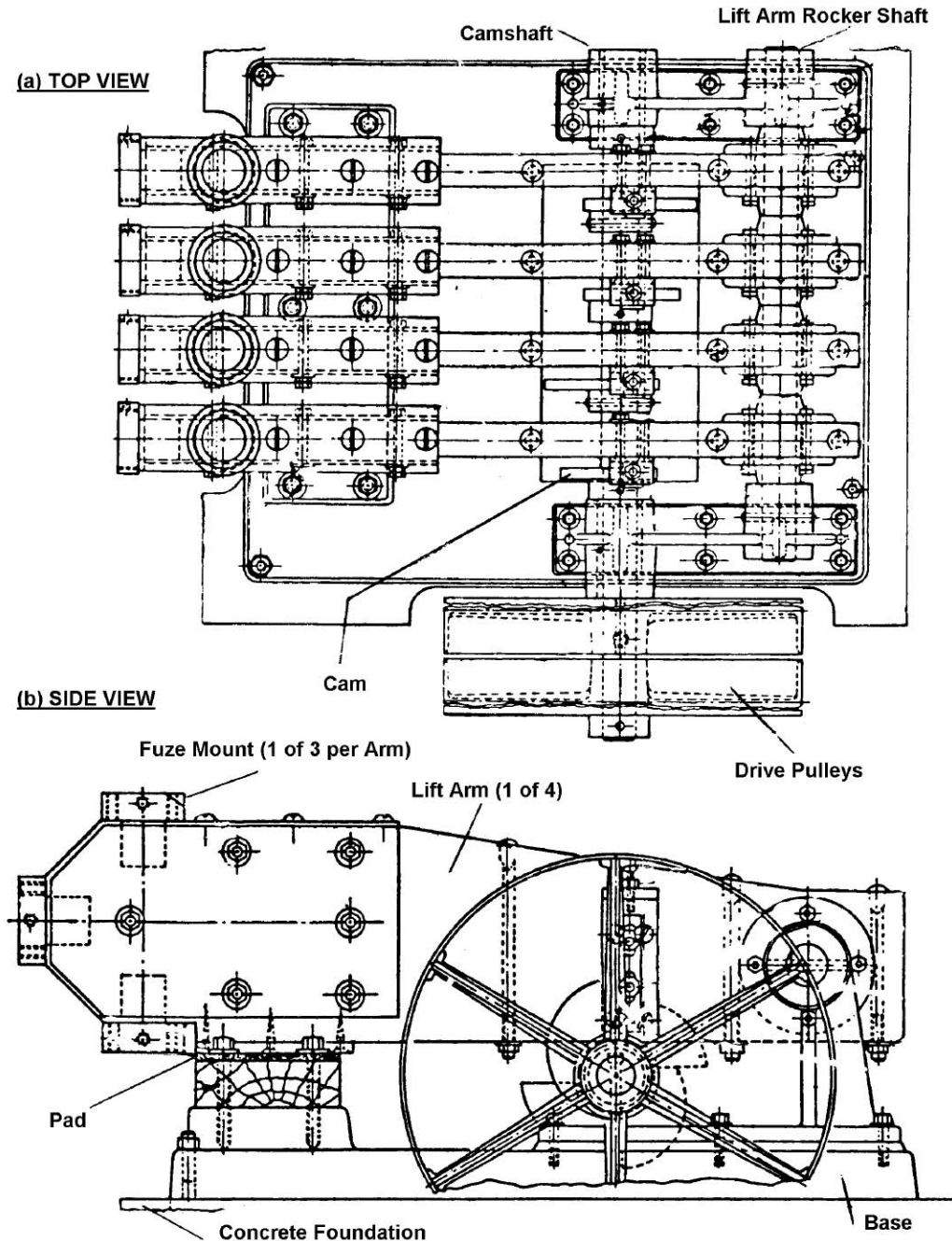

FIGURE A1-1. Jolt machine.

MIL-STD-331C
w/CHANGE 1
APPENDIX A

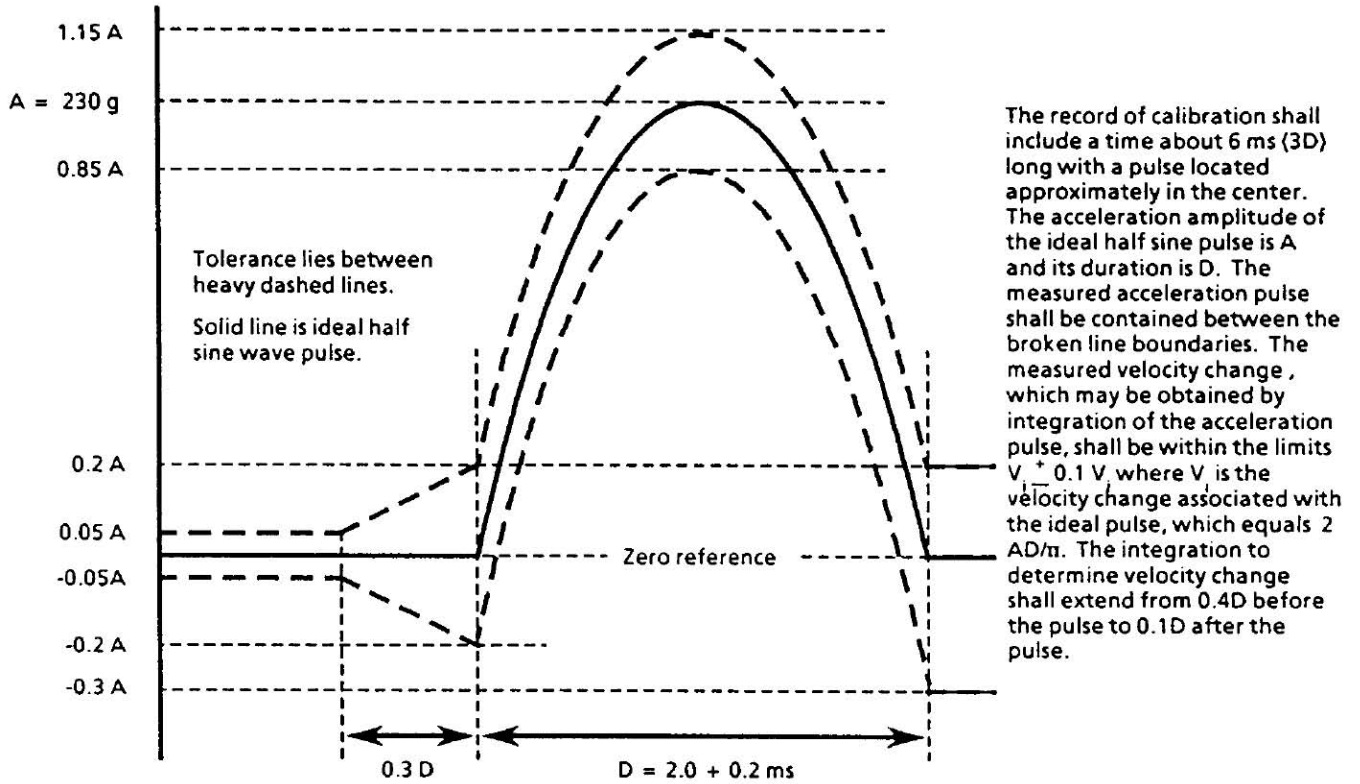

FIGURE A1-2. Half-Sine Shock Pulse and Tolerance

TEST A2.1

JUMBLE

A2.1 PURPOSE.

This is a laboratory safety test simulating repeated impacts that may occur in the transportation environment. The fuze must withstand random impacts imparted by free-fall inside a rotating, closed, lined box.

A2.2 DESCRIPTION

A2.2.1 General. The test box containing a loose fuze is rotated at a speed of 30 +/-2 revolutions per minute for a total of 3600 +/-10 revolutions. The inside dimensions of the box are sufficiently larger than the external fuze dimensions so that the fuze can tumble freely. During box rotation, the fuze impacts the interior surfaces at random. Three different size boxes are required to accommodate testing of the size range of fuzes not to exceed 381 mm (15 in) maximum dimension.

A2.2.2 Fuze configuration. The fuzes shall be completely assembled, including all explosive elements which are a part of the fuze design.

A2.2.3 Applicable publications. All standards, specifications, drawings, procedures and manuals which form a part of this test are listed in Section 2 of the introduction to this standard. Special attention is directed to Army drawing 81-3-35 and Navy drawings QEL 1386-1 through -45 and QEL 1387-1 which provide details of the jumble machine.

A2.2.4 Test documentation. Test plans, performance records, equipment, conditions, results and analysis shall be documented in accordance with 4.8 of the general requirements to this standard.

A2.3 CRITERIA FOR PASSING TEST

A2.3.1 Fuze condition. At the completion of this test, the fuze shall be safe for transportation, storage, handling and use in accordance with 4.6.2.1a of the general requirements to this standard. The fuze does not have to be operable.

A2.3.2 Decision basis. Breakdown, inspection, other appropriate tests and engineering judgment shall form the basis for the decision that fuzes have passed or failed the test.

A2.4 EQUIPMENT

A2.4.1 Test equipment design. The test equipment shall conform to Naval Surface Warfare Center, Crane Division drawings QEL 1386-1 through -45. It consists of three sizes of wood-lined metal boxes and the necessary structure and drive mechanism to support and rotate one or more of the boxes on the axis indicated in the drawings. Refer to Figure A2-1.

A2.4.2 Box sizes. The size of box required for a test shall depend on the size of the fuze being tested. Three test box sizes have been standardized to test fuzes having a maximum dimension of 381 mm (15 in). The requirements to test fuzes having a maximum dimension greater than 381 mm (15 in) was not considered to occur often enough to economically warrant requiring an additional box as part of the standard equipment. However, when such fuzes are to be tested, it is necessary that the proper size and type of test box is used. For fuzes having a

MIL-STD-331C
w/CHANGE 1
APPENDIX A

maximum dimension greater than 381 mm (15 in) and up to and including 508 mm (20 in), the test box shall be identical to the other three boxes in materials, construction, axis of revolution, and mounting position. For fuzes with a maximum dimension exceeding 508 mm (20 in), it is recommended that other methods of testing to this type of environment, such as the loose cargo transport test of MIL-STD-810, be devised.

A2.4.3 Material substitution. Polyethylene sheet having the properties shown in Table A2-I may be substituted for the maple wood box liner specified in Drawing QEL 1386.

TABLE A2-I. Physical Properties of Polyethylene Sheet High Molecular Weight

Properties	ASTM Test Method	Value
1. Hardness: Rockwell Shore	D785 D2240	R64 R67
2. Specific gravity	D792	0.940
3. Shear strength, psi	D732	3,500
4. Bend creep modulus, psi	NA	110,000
5. Impact strength, ft-lb/in of notch (Bar Izod Test) @ +23°C and @ -140°C	D256A	No break

Note: Allowable tolerances are ±10 percent of the listed value.

A2.5 PROCEDURE

A2.5.1 Select test box. Determine the maximum dimension of the fuze being tested (usually a diagonal measurement) and using this dimension, select the applicable box for use from Table A2-II.

TABLE A2-II. Selection of Test Boxes.

Maximum Fuze Dimension, mm (in)	Box Designation	Test Box Inside Reference Dimension without Liner, mm (in)			Drawing
		Height	Width	Length	
Less than 127 (5)	A	165 (6.5)	318 (12.5)	445 (17.5)	QEL 1386-4
127 to 254 (5 to 10)	B	292 (11.5)	394 (15.5)	546 (21.5)	QEL 1386-5
254 to 381 (10 to 15)	C	445 (17.5)	495 (19.5)	648 (25.5)	QEL 1386-6

MIL-STD-331C
w/CHANGE 1
APPENDIX A

Greater than 381 (15)	See A2.4.2				
--------------------------	------------	--	--	--	--

A2.5.2 Inspect Equipment. Verify that the equipment is in good operating condition:

- a. All working parts are structurally sound and all screw and bolt connections are tight.
- b. The liner of the test box is in good condition, having a required thickness of 6.35 mm (1/4 in) minimum in the impact areas.
- c. The machine, including the test box, is electrically grounded.

A2.5.3 Place fuze in box. Place one bare fuze in the box and secure the cover. No more than one fuze per box is permitted even if more than one fuze is to be tested.

A2.5.4 Operate machine. Rotate the box through 3600+/-10 revolutions at a speed of 30 +/-2 rpm, 2 hours nominal run time.

A2.5.5 Compliance. At the completion of the required revolutions, remove fuze from test box. Analyze the test results and determine whether or not the test article meets the pass/fail criteria in Section A2.3. Continue testing the specified number of items.

A2.6 ALTERNATE AND OPTIONAL TESTS

None.

A2.7 RELATED INFORMATION

A2.7.1 Jumble test background. The jumble test has been used for many years to establish the safety and ruggedness of fuze designs under severe conditions of transportation. Although transport vehicles have changed in nature since the test was first devised, the occurrence of a "rough environment" of transportation is considered to have remained essentially of the same severity. This test therefore continues to be used as a ruggedness test of fuze designs.

A2.7.2 Protective fixtures. Historically, certain types of fuzes have been tested in protective fixtures. This practice was a deviation from the test intent and should not have been applied to fuzes which entered development phase testing after 15 April 1974. Accordingly, on 30 June 1976, a revision to Jumble Test 102.1 deleted the reference to the "Fixture for Jumbling Fuzes", which is drawing 81-3-37.

A2.7.3 Jumble box dimensions. Table A2-II has been revised to make the dimensions consistent with those of Drawings QEL 1386-4, -5 and -6. The revised dimensions do not include the liner.

A2.7.4 Liner material substitution. Substitution of polyethylene sheet for maple wood as the jumble box liner material provides a similar test environment and offers significant advantages. It wears about six times more slowly. Consequently, the use of polyethylene shall be more uniform and consistent with time, from piece to piece, and among different test facilities. Experience has shown that the procurement cycle for polyethylene is significantly shorter than that for wood. Refer to Frankford Arsenal Technical Report 75077 (Paragraph A2.7.5, b.) for more information.

A2.7.5 Bibliography.

- a. JANAF Fuze Committee Journal Article No. 28, *Jumble Test History*, September 1963.
- b. Frankford Arsenal Technical Report 75077, *Improvements to Fuze Test Methods and Development of New Monitoring Techniques*, National Technical Information Service (NTIS) No. AD-A024032, 5285 Port Royal Road, Springfield, VA 22161.

MIL-STD-331C
w/CHANGE 1
APPENDIX A

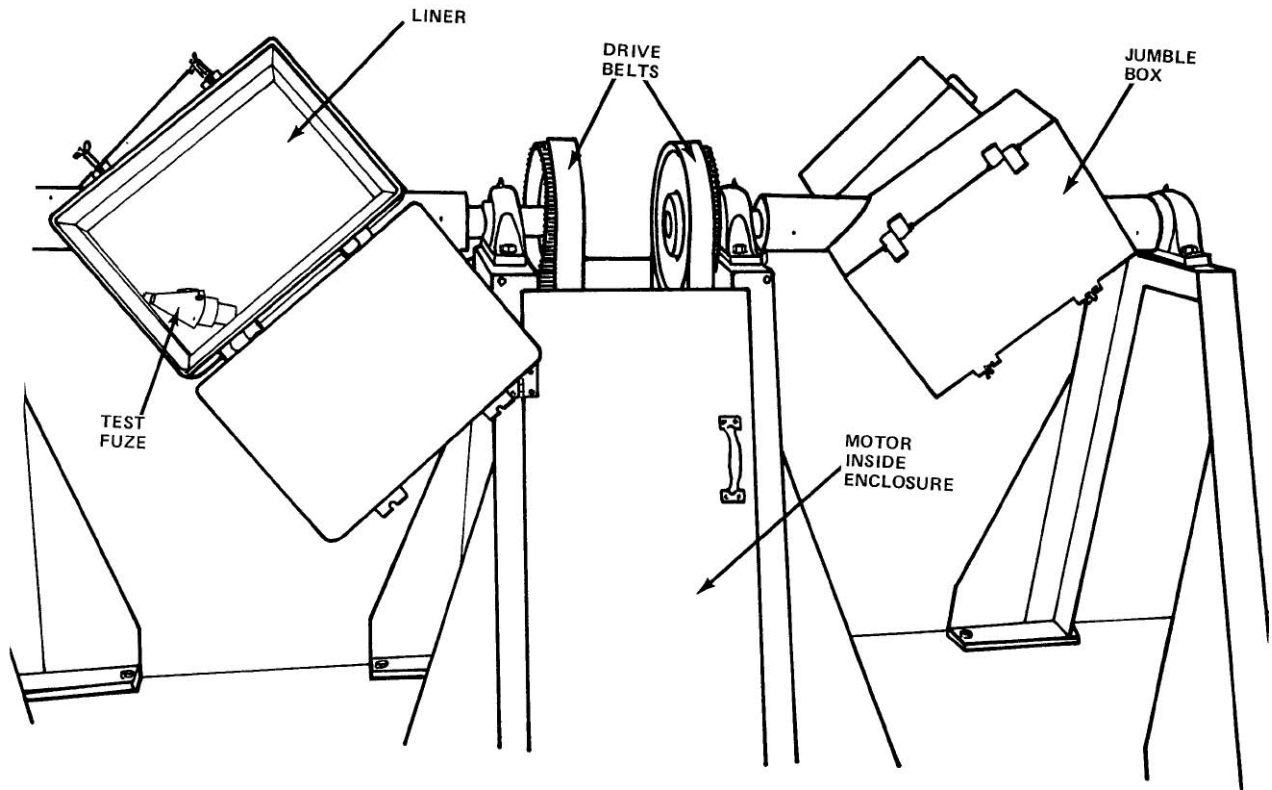

Figure A2-1. Jumble Box.

TEST A3 TWELVE METER (40-FOOT) DROP

A3.1. PURPOSE

This is a laboratory or field safety test simulating loading and unloading ammunition on ships. The fuze or fuzed munition must withstand a 12 m (40 ft) free-fall drop.

A3.2. DESCRIPTION

A3.2.1 General. The test item is dropped onto a steel plate from a height of 12 m (40 ft) measured from the lowest point of the test item to the plate. The complete test consists of a series of five drops at different impact orientations. Each fuze is dropped only once.

A3.2.2 Fuze/munition configuration. The test item configuration depends on how the fuze or fuzed munition is delivered for service use.

A3.2.2.1 Unpackaged, fuzed munition. The fuze is assembled to the munition and the assembly is shipped unpackaged.

A3.2.2.2 Packaged, fuzed munition. The fuze is assembled to the inert munition and the assembly is shipped in a service package.

A3.2.2.3 Packaged fuze. The fuze is shipped separately from the munition in the service package. When the exterior pack is a bulk pack and the number of explosive-loaded fuzes available for this test is not sufficient to provide a complete pack, dummies (or inert fuzes) of similar exterior configuration and mass may be used to fill out the pack. When dummies (or inert fuzes) are used as filler, the explosive-loaded fuzes shall be located in positions where they shall be subjected to the most severe test conditions. Engineering judgement may be required to determine these locations. If such a determination cannot be made, distribute the fuzes uniformly within the pack.

A3.2.3 Applicable publications. All standards, specifications, drawings, procedures and manuals which form a part of this test are listed in Section 2 of the introduction to this standard.

A3.2.4 Test documentation. Test plans, performance records, equipment, conditions, results, and analysis shall be documented in accordance with Section 4.8 of the general requirements to this standard. In addition, test plans shall specify: (a) type and weight of explosives, (b) fuze orientation or position within the package, and (c) filler (inert items or material) used to obtain proper shipping weight and configuration.

A3.3. CRITERIA FOR PASSING TEST

A3.3.1 Fuze condition. At the completion of this test, the fuze shall be safe for disposal in accordance with 4.6.2.1b of the general requirements to this standard.

A3.3.2 Allowable detonations. As a result of design characteristics, some explosive elements of certain point-detonating or base-detonating types of fuzes shall function on nose impact, but these fuzes shall pass this test if no explosive element beyond the safety interrupter is burned or detonated.

A3.3.3 Decision basis. Breakdown, inspection, other appropriate tests and engineering judgment shall form the basis for the decision that fuzes have passed or failed the test.

A3.4 EQUIPMENT

MIL-STD-331C
w/CHANGE 1
APPENDIX A

A3.4.1 Drop tower. The 12 m (40 ft) height necessary to perform this test can be obtained by using any tower, derrick, or boom arrangement, provided the conditions of free-fall and impact are met.

A3.4.2 Impact surface. The impact surface shall be steel plate having a minimum thickness of 75 mm (3 in) and a Brinell hardness of not less than 200. It shall be solidly supported in a horizontal plane over its entire bearing area by a minimum of 460 mm (18 in) of reinforced concrete or crushed rocks. The plate shall have a flat surface (not deformed from previous test impacts to the point where further proper angular impacts are prevented), and shall have a length and width of at least 2 times the maximum dimension of the test item. The plate may be surrounded by a suitable enclosure in order to contain the rebounding test item.

A3.4.3 Guide. A guidance system may be employed to ensure the proper impact angle. For example, a vertical steel tube may be used for nose or tail impacts; however, the guidance system shall be disengaged at a sufficient height above the impact plate to permit unimpeded free-fall and rebound to occur. The guidance shall not reduce the impact velocity of the item being dropped by more than 2 percent of the velocity the item would have achieved in a 12 meter (40 ft) free-fall.

A3.4.4 Auxiliary equipment. Equipment such as an electric hoist, a remotely- controlled magnetic release, and a work bench is recommended.

A3.5. PROCEDURE

A3.5.1 Impact plate inspection. Examine the impact plate for defects such as dishing, pockmarking, spalling, and so forth which would reduce the anvil effect or the actual angle of contact between the drop vehicle and the plate to such an extent that the test would be invalid. Replacement of the plate shall be determined by engineering judgement.

A3.5.2 Fuze/munition preparation. Determine the service issue configuration for the fuze or fuzed munition being tested and prepare the test items as described below.

A3.5.2.1 Fuze and booster configuration. The fuzes shall be completely assembled, unarmed and include all explosive elements. An inert booster may be substituted for a live booster: (a) during production acceptance testing, (b) when permitted by the item specification, or (c) when a live booster presents an excessive hazard. The inert booster shall be the same weight and size as the live booster.

A3.5.2.2 Munition. For fuzed munitions, the fuze shall be assembled to the inert-loaded version of the munition. The inert load of the test munition shall simulate closely the weight, consistency, and compressive strength of the replaced explosives. If the munition (projectile, bomb, rocket, and so forth) exceeds either 230 kg (500 lb) or 155 mm caliber, its fuze shall be attached to a test vehicle which weighs 230 + 20 kg (500 + 44 lb). The test vehicle shall be 1.5 m (5 ft) in length and its impacting surfaces shall simulate closely the contour, hardness, and rigidity of the corresponding surfaces of the service munition.

A3.5.3 Temperature. A complete series of tests shall be conducted with the test items at ambient temperature. The test directive may specify additional testing at extreme temperatures when materials or components are suspected of being vulnerable to these conditions.

A3.5.4 Drop item. Conduct one drop each with the longitudinal axis of the test item orientated within ± 10 degrees of:

- a. vertical with nose down,
- b. vertical with nose up,
- c. horizontal,
- d. 45 degrees from vertical with nose down, and

e. 45 degrees from vertical with nose up.

A3.5.4.1 Longitudinal axis. The longitudinal axis of the test item is parallel to the line of flight axis of the weapon. In the case of packaged fuzes, the longitudinal axis of the test item is the nose-to-base axis of the fuze.

A3.5.4.2 Package orientation. If the test item is a tactical or overseas package, one package shall be dropped in such a manner to assure fuze impact at each of the orientations as specified above.

A3.5.4.3 Radial orientation. For drops other than vertical with nose down and vertical with nose up, the radial orientation of the test fuze shall expose the most critical or vulnerable plane of the fuze to impact as determined by engineering judgement or past experience with the design.

A3.5.4.4 Velocity. The technique for obtaining impact velocity shall be as specified in Section A3.4.3.

A3.5.4.5 Reuse of material. Each fuze and package may only be dropped once. The inert munition or test vehicle may be reused in subsequent drop tests if damage previously incurred shall not affect ensuing test results.

A3.5.5 Compliance. Analyze the test results and determine whether or not the test article meets the pass/fail criteria in Section A3.3. Continue testing the specified number of items.

A3.6. ALTERNATE AND OPTIONAL TESTS

Other drop heights or impact surfaces. The 12 m (40 ft) drop test has been used for many years in fuze safety tests. Although the test is not a direct simulation of field or fleet conditions, it represents free-fall possibilities of a fuze, projectile, bomb, missile or other munition during handling from dock to ship, or the possibility of falls between-decks onboard ship. If other drop heights or impact media are considered possible in service use and the fuze is vulnerable to these conditions, fuzes should also be tested in these conditions.

A3.7. RELATED INFORMATION

Bibliography.

Frankford Arsenal Technical Report 75077, *Improvements to Fuze Test Methods and Development of New Monitoring Techniques*, National Technical Information Service (NTIS) No. AD-A024032, 5285 Port Royal Road, Springfield, VA 22161.

TEST A4.1

ONE AND ONE-HALF METER (FIVE-FOOT) DROP

A4.1. PURPOSE

This is a laboratory safety and reliability test simulating handling and tactical conditions. Each unpackaged fuze or fuzed munition must be able to withstand the required number of 1.5 m (5 ft) drops onto a steel plate.

A4.2. DESCRIPTION OF TEST

A4.2.1 General. This test simulates severe shocks encountered during accidental mishandling in manufacture, transportation, or service use of fuzes. As examples, fuzes or fuzed munitions may fall off a conveyor belt or truck or be dropped during weapon loading. Either bare fuzes or fuzes mounted in a suitable, inert-loaded munition are dropped 1.5 m (5 ft) onto a steel plate which is solidly supported by gravel or concrete. The equipment shall provide an unimpeded free-fall drop of 1.5 m (5 ft), or a velocity of 5.5 m/s (18 ft/s) prior to the fuze striking the plate and rebounding. There are five required impact orientations: (1) nose down, (2) base down, (3) horizontal, (4) 45 degrees nose down, and (5) 45 degrees base down. The test directive shall specify which of the following procedures shall be used.

A4.2.1.1 Two-drop procedure. The fuzes are dropped at least twice so that all combinations identified in Table A4-I are tested. The developer, tester or evaluator and service review authority may consider a single drop in one or more orientations adequate to meet the requirements of this test provided an in-depth safety analysis or preliminary test results show conclusively that, after one drop in some orientation, the fuze is obviously damaged beyond use and the safety features have not been compromised. Two drops are required in all other cases.

Table A4-I. Two-Drop Test Schedule

Drop	Sample No.				
	1 thru 5	6 thru 10	11 thru 15	16 thru 20	21 thru 25
First	AAAAA	BBBBB	CCCCC	DDDDD	EEEEE
Second	ABCDE	ABCDE	ABCDE	ABCDE	ABCDE

Legend: A - nose down; B - base down; C - horizontal; D - 45 degrees nose down; E - 45 degrees base down.

A4.2.1.2 Single-drop procedure. For those test items whose cost or availability preclude testing 25 items, such as some missile fuzes and safety and arming devices, a minimum of five fuzes or inert fuzed munitions shall be dropped once each, one at each orientation described above. A second drop shall be optional.

A4.2.2 Fuze configuration. Fuzes shall be tested at ambient temperature. All fuze explosive components shall be present and fuze safety features in use during the test. An inert

MIL-STD-331C
w/CHANGE 1
APPENDIX A

lead and booster may be substituted for live components during production acceptance testing, when permitted by the item specification, or when use of a live booster constitutes an excessive hazard. The inert lead and booster components shall have an equivalent weight and configuration.

A4.2.3 Use of a munition. The fuze shall be tested as a separate item or attached to the inert munition for which it is intended, depending on the normal method of shipment. If the fuze is shipped both separately and attached to its munition, it shall be tested both ways. For tests involving the use of an inert projectile, rocket, bomb and so forth, the munition shall closely simulate the weight, consistency and weight distribution of the replaced explosives. When a munition exceeds 250 kg (550 lb), the fuze may be attached to a test vehicle which weighs at least 250 kg (550 lb). For rockets or guided missiles more than 1.5 m (5 ft) in length, use an inert test vehicle at least 1.5 m (5 ft) long. Fuzes that could be used in a variety of munitions should be mounted on the munition which shall provide the most severe environment based on the safety analysis or preliminary testing.

A4.2.2 Applicable publications. All standards, specifications, drawings, procedures and manuals which form a part of this test are listed in Section 2 of the introduction to this standard. Special attention is directed to Navy Bureau of Yards and Docks Drawing No. 40897, Drop Tower Construction, which describes an optional test fixture.

A4.2.3 Test documentation. Test plans, performance records, equipment, conditions, results, and analysis shall be documented in accordance with Section 4.8 of the general requirements to this standard.

A4.3. CRITERIA FOR PASSING TEST

A4.3.1 Fuze condition. The development test plan or product specification shall specify one of the pass/fail criteria stated below. In general, nose-mounted fuzes dropped in any of the nose down positions, and protruding base fuzes dropped in any of the base down positions must be safe to use, but are not required to be operable.

A4.3.1.1 Safe to use. At the completion of this test, the fuze shall be safe for transportation, storage, handling and use in accordance with 4.6.2.1a of the general requirements to this standard. The fuze does not have to be operable.

A4.3.1.2 Safe to use and operable. At the completion of this test, the fuze shall be safe for transportation, storage, handling and use, as well as operable in accordance with 4.6.2.1a and 4.6.2.2 of the general requirements to this standard.

A4.3.2 Decision basis. Breakdown, inspection, other appropriate tests and engineering judgment shall form the basis for the decision that fuzes have passed or failed the test.

A4.4. EQUIPMENT

A4.4.1 Drop fixture. The 1.5 m (5 ft) height required for this test can be obtained by using a steel tower, derrick or a horizontal beam extending from an existing structure. Navy Bureau of Yards and docks Drawing No. 40897, shows the construction of a typical drop tower. The fixture should allow a quick release which does not disturb the orientation of the item at the moment of drop.

A4.4.2 Impact plate. The steel plate upon which impact occurs shall have a minimum thickness of 75 mm (3 in), a Brinell hardness of 200 or greater, and shall be solidly supported in a horizontal plane over its entire bearing area by a minimum thickness of 0.6 m (2 ft) of gravel or concrete. The surface of the impact plate shall be flat having length and width at least one and one-half (1 ½) times the maximum dimension of the test item being dropped. The plate shall be surrounded on all four sides by an enclosure of sufficient height and strength to contain the

rebounding test item.

A4.4.3 Guidance system. Various guidance systems may be employed to ensure the correct impact angle. For example, a vertical steel tube may be used for guiding nose or base impact. However, any guidance shall be positioned high enough above the striking plate to allow unimpeded fall and rebounding.

A4.4.4 Other equipment. Other supporting equipment, such as temperature conditioning equipment, an electric hoist, a remotely controlled release, and a fuze recovery work table are recommended.

A4.5 PROCEDURE

A4.5.1 Test setup. Prepare the test equipment as described in A4.2 and A4.4. Refer to the test directive and configure the test items using live or inert boosters and bare fuzes or fuzes mounted to an appropriate munition.

A4.5.2 Fuze orientation. The test item shall be oriented to impact: (1) nose down, (2) base down, (3) horizontal, (4) 45 degrees nose down, and (5) 45 degrees base down. The tolerance from the required orientations shall be ± 10 degrees. For drops other than nose or base down, orient the test item to expose the most critical or vulnerable plane of the fuze to impact. This is determined by engineering judgment or past experience with the design. The orientations of the test item shall be recorded.

A4.5.3 Drop. Drop the test item 1.5 m (5 ft) (lowest point of the test item to point of impact) or achieve an impact velocity of 5.5 m/s (18 ft/s) $\pm 5\%$. Each test item shall be dropped twice in accordance with Table A4-I unless the single-drop test described in A4.2.1.2 has been specified in the test directive.

A4.5.4 Recovery. Before handling, examine the dropped assembly for visible evidence of unsafe conditions. Recover the fuze using approved recovery methods.

A4.5.5 Safety compliance. Inspect each fuze to determine that it is safe to use in accordance with Paragraph 4.6.2.1a of the general requirements to this standard.

A4.5.6 Continue testing. Continue testing the specified number of items. The test munition and steel impact plate may be reused as long as they are not damaged or work hardened to the extent that they influence further tests.

A4.5.7 Operational compliance. If operation of the fuze is specified by the test directive, perform appropriate additional tests and evaluate the results in accordance with 4.6.2.2 of the general requirements to this standard.

A4.6. ALTERNATE AND OPTIONAL TESTS

A4.6.1 Extreme temperature. Preconditioning fuzes to extreme temperatures such as $+71^{\circ}\text{C}$ ($+160^{\circ}\text{F}$) and -54°C (-65°F) may be specified as additional requirements.

A4.6.2 Impact surface. Soft earth, water, fiberboards, or similar substances may be specified during fuze development, if the fuze is considered to be more vulnerable to a shock of low peak acceleration and long duration.

A4.6.3 Drop height. Drop testing at different heights, such as, 2.1, 3.0, 3.7, and 4.5 m (7, 10, 12, and 15 ft) may be specified as additional requirements.

A4.6.4 Fuze safety features. The test may be performed with each safety feature alternately disabled to demonstrate the ability of remaining safety features to provide independent safety.

A4.7 RELATED INFORMATION

None.

TEST A5

TRANSPORTATION HANDLING (Packaged Fuzes)

A5.1 PURPOSE

This is a laboratory safety and reliability test simulating handling conditions. Packaged fuzes or fuzed munitions are preconditioned to specified temperatures and subjected to controlled drops, rollovers, and impacts.

A5.2 DESCRIPTION

A5.2.1 General. Fuzes or fuzed munitions in the standard package are preconditioned to ambient and extreme temperatures and subjected to a series of free-fall, edgewise and cornerwise drops, rollover and pendulum impacts. This test applies to fuzes packaged for Level A, maximum military protection, in accordance with AR 700-15 (See Section A5.7.7), and which are shipped as spares inventory or to a weapon or munitions assembly point. A package shall be subjected to all of its tests without being repaired or reworked. Separate procedures are provided for testing small and large packages. Sections A5.2 thru A5.5 of this test generally apply to fuzes developed since 18 May 1982. Alternate procedures which may be specified in production specifications for older fuzes are included in Section A5.6.

A5.2.1.1 Small packages. This procedure applies to standard packages having a gross mass of 68 kg (150 lb) or less and having no dimension greater than 1.5 m (5 ft).

A5.2.1.1.1 Fuzes not issued to ground troops. Fuzes are subjected to six 0.9 m (3 ft) free-fall drops onto a rigid horizontal surface.

A5.2.1.1.2 Fuzes issued to ground troops. Fuzes are subjected to six 0.9 m (3 ft) drops followed by one 2 m (7 ft) free-fall drop onto a rigid horizontal surface.

A5.2.1.2 Large packages. This procedure applies to standard packages having a gross mass more than 68 kg (150 lb) or having any dimension greater than 1.5 m (5 ft). The packaged fuzes are subjected to rollover, edgewise and cornerwise drops and pendulum impact.

A5.2.2 Fuze and munition configuration. The fuzes shall be completely assembled, including all explosive elements which are part of the fuze design. Fuzes that are normally shipped as part of the round shall be tested assembled to the associated live or inert-loaded (equivalent mass and configuration) munition in the packaged configuration. "Fuze" as used throughout this test shall refer to the fuze or a fuzed munition as applicable.

A5.2.2.1 Use of dummy or inert fuzes. When the exterior package is a bulk package (more than one fuze) and the quantity of explosive-loaded fuzes is not sufficient to provide a complete package, dummy or inert fuzes of similar exterior configuration and mass may be used to fill out the package. When dummy or inert fuzes are used as fillers, explosive-loaded fuzes shall be located so as to be subjected to the most severe test conditions.

A5.2.2.2 Combined tests. This test is intended to be performed in conjunction with Test B2, Transportation Vibration (Packaged Fuzes). The two tests constitute a total vibration-handling-temperature test. When Tests A5 and B2 are conducted sequentially on the same package and dummy or inert fuzes are used as fillers, the orientation of the available explosive-loaded fuzes (ELF) within the package shall take into consideration both the transportation-vibration and handling shock environments. Engineering judgment shall be used in selecting a compromise

MIL-STD-331C
w/CHANGE 1
APPENDIX A

between uniform distribution of ELF for vibration testing and specific orientation of ELF for handling shock testing. The consideration should place a strong emphasis on testing to the shock environment, that is, placing fuzes at corners for rectangular packages and at edges for cylindrical packages, since the shock transmission is usually the most severe at these locations. Typical sequences of tests for standard packages are shown in Figures A5-4 and A5-5 respectively.

A5.2.2.3 Sample size. Table A5-I shows the minimum number of packages which shall be tested at each temperature.

TABLE A5-I. Minimum Number of Test Packages

Package Size	Test Temperature (°C)			Total Packages Required
	+71	+23	-54	
Small packages (fuzes not issued to ground troops)	1	1	1	3
Small packages (fuzes issued to ground troops) (If each package contains more than 6 fuzes and the required fuzes are not available)	6 (2)	6 (2)	6 (2)	18 (6)
Large packages (bulk fuzes)	1	1	1	3

A5.2.3 Applicable publications. All standards, specifications, drawings, procedures and manuals which form a part of this test are listed in Section 2 of the introduction to this standard. Special attention is directed to MIL-HDBK-310, ASTM-D6199, MIL-STD-810, AR 70-38, AR 700-15, TOP 4-2-601, TOP 4-2-602 and ASTM-D-880.

A5.2.4 Test documentation. Test plans, performance records, equipment, conditions, results, and analysis shall be documented in accordance with Section 4.8 of the general requirements to this standard. Additional documentation requirements are as follows.

A5.2.4.1 Optional temperature levels. Specify the temperature level if other than those given by this test.

A5.2.4.2 Acceptable minor damage. Define “minor damage” acceptable to exterior package.

A5.3 CRITERIA FOR PASSING TEST

A5.3.1 Fuze condition. At the completion of this test, the fuze shall be safe for transportation, storage, handling and use, as well as operable in accordance with 4.6.2.1a and 4.6.2.2 of the general requirements to this standard. See A5.7.3 and A5.7.5.

A5.3.2 Package condition. Minor damage to the standard package, for example, loose nails, split wood, bent box hardware, dents in fiber container/metal cans, and so forth, that shall not affect the intended continued use of the package is permissible. However, the package must not spill its contents, must be capable of being handled, stacked, and stored and must not compromise fuze protection.

MIL-STD-331C
w/CHANGE 1
APPENDIX A

A5.3.3 Decision basis. Breakdown, inspection, other appropriate tests and engineering judgment shall form the basis for the decision that fuzes have passed or failed the test. See A5.7.4.

A5.4 EQUIPMENT

A5.4.1 Temperature conditioning equipment. Equipment shall be capable of establishing and maintaining the packaged fuzes at specified temperatures in the range of +71°C (+160°F) and -54°C (-65°F).

A5.4.2 Free-fall drop equipment. This is required for small and large package tests.

A5.4.2.1 Rigid horizontal impact surface. Equipment shall consist of a 75 mm (3 in) minimum thick steel plate with a minimum Brinell hardness of 200 Bh supported by a minimum of 460 mm (18 in) of concrete or crushed rocks. Refer to US Army TOP-4-2-601.

A5.4.2.2 Lifting mechanism.

A5.4.2.3 Quick-release device.

A5.4.2.4 Instrumentation. Not required unless otherwise specified.

A5.4.3 Edge and corner drop equipment. In addition to equipment specified in Paragraph A5.4.2, support blocks are required for large package tests. Refer to A5.5.3.1 and A5.5.3.2 for sizes.

A5.4.4 Pendulum impact equipment. This is required for large package tests.

A5.4.4.1 Vertical impact surface. A flat, rigid concrete or masonry wall, or other equally unyielding flat barrier high and wide enough to make full contact with the container end.

A5.4.4.2 Four ropes, chains or cables. These shall be capable of suspending the packages at least 5 m (16 ft) above the ground.

A5.4.4.3 Instrumentation. A transducer capable of measuring the impact velocity.

A5.4.5 Incline impact equipment. This equipment is used when the incline impact test is performed as an alternate to the pendulum impact test.

A5.4.5.1 Two-rail steel track. This shall be inclined 10 degrees from the horizontal.

A5.4.5.2 Rolling carriage dolly.

A5.4.5.3 A rigid backstop (barrier). This shall have a face made of Group 4 woods (hard) IAW ASTM D6199 of sufficient size to permit full contact with the container end. The backstop shall be perpendicular to the track.

A5.4.5.4 Instrumentation. A transducer capable of measuring impact velocity.

A5.5 PROCEDURE

A5.5.1 General requirements. The requirements below shall apply to both small and large package tests.

A5.5.1.1 Tolerances. The maximum allowable tolerances of test conditions (exclusive of accuracy of instruments) not specified in 4.5.2 of the introduction to this standard or material specifications shall be as follows:

Temperature	±10°C (±18°F) at +23°C (+73°F) ±2°C (±4°F) at +71°C (+160°F) ±2°C (±4°F) at -54°C (-65°F)
Distance	±5%
Time	±3%

MIL-STD-331C
w/CHANGE 1
APPENDIX A

Velocity	±5%
----------	-----

A5.5.1.2 Drop and impact conditions. The heights as specified in subsequent paragraphs refer to the distance from the rigid surface to the nearest corner, edge or flat surface of the fuze package (container).

A5.5.1.3 Temperature conditioning. See A5.7.2. Precondition the number of packages specified in Table A5-1 to -54°C (-65°F), +23°C (+73°F) and +71°C (+160°F) for 16 hours minimum. Immediately after the appropriate number of test articles have been preconditioned, perform the test in accordance with Sect A5.5.2 or A5.5.3 depending on the size of the package or container. No more than 2 to 3 minutes shall elapse before the first drop or impact is conducted with no more than 8 to 10 minutes elapsed time before drops are completed for a given test sequence, that is, six 0.9 m (3 ft) drops.

A5.5.2 Small Packages (68 kg (150 lb) or less).

A5.5.2.1 Test setup. Prepare the test equipment listed in A5.4.2 for free-fall drops.

A5.5.2.2 One-meter (3 ft) drop. Drop each package free-fall a total of six times from a height of 0.9 m (3 ft). Observe the orientations described below. Refer to Figure A5-1.

A5.5.2.2.1 Rectangular packages. Conduct the first four drops with the package impacting once each on its bottom, side, top and left end. The order of flat drop orientations is optional. Conduct the last two drops with the package impacting on the top left end corner and bottom right end edge at a 45 degree angle.

A5.5.2.2.2 Cylindrical packages. Conduct the first four drops with the package impacting once each on the top and bottom and twice on the side at 90 degree intervals. The order of the flat drop orientations is optional. Conduct the last two drops with the package impacting on the top edge (locking ring lug, when applicable) and the bottom edge at 45 degree angles. The order of the edge drops is optional.

A5.5.2.3 Two-meter (7 ft) drop. This drop applies only to small fuze packages issued to ground troops. Following the six 0.9 m (3 ft) drops described in 5.2.2, each package shall be dropped once from a height of 2 m (7 ft). See A5.7.6. Each of the six packages shall impact in a different orientation. See Figure A5-1. If only two packages per temperature are being tested, the test shall be conducted as described in A5.5.2.3.1 and A5.5.2.3.2, except that the six orientations of 2 m (7 ft) drops shall be reduced to two orientations, each different, per temperature. This shall provide a total of six different orientations of 2 m (7ft) drops over 3 temperatures.

A5.5.2.3.1 Rectangular package. Each package shall be dropped once, free-fall from a height of 2 m (7 ft) onto the impact surface. The impact orientation shall be bottom, side, top, left end, top left end corner at 45 degrees and bottom right end edge at 45 degrees. The order of flat and edge drops is optional.

A5.5.2.3.2 Cylindrical package. Each package shall be dropped once, free-fall from a height of 2 m (7 ft) onto the impact surface. The impact orientation shall be top, bottom, twice on the side at 90 degree intervals, top edge (locking ring lug, when applicable) at 45 degrees and the bottom edge at 45 degrees.

A5.5.3 Large packages (greater than 68 kg (150 lb)). Each of the three containers shall be subjected to six edgewise drops, six cornerwise drops, one rollover, and two pendulum impacts as described in A5.5.3.1 thru A5.5.3.4. The incline impact test described in A5.5.3.5 is an option to the pendulum test.

A5.5.3.1 Edgewise drop. The container shall be supported on one end of its base on a

MIL-STD-331C
w/CHANGE 1
APPENDIX A

block approximately 130 mm (5 in) high. The opposite end of the container shall be raised and allowed to drop freely from heights of 0.3, 0.6 and 0.9 m (1, 2 and 3 ft) onto the impact surface. Three drops from the same heights shall be applied to each end of the container for a total of six drops. The order of drops is shown on Figure A5-2. If there is no specific skid orientation as shown on Figure A5-2, apply the test to two container surfaces. One container surface is perpendicular to the longitudinal axis of the container and the other container surface is parallel to the longitudinal axis of the container.

A5.5.3.2 Cornerwise drop. The container shall be supported at the corner of its base on a block 130 mm (5 in) high. A block 0.3 m (1 ft) high shall be placed under the other corner of the same end of the container. The opposite end of the container shall be raised and allowed to fall freely from heights of 0.3, 0.6 and 0.9 m (1, 2 and 3 ft) onto the impact surface. Three drops from the same height shall be applied to diagonally opposed corners of the container base for a total of six drops. The order of tests is shown in Figure A5-3. If there is no specific skid orientation as shown in Figure A5-3, apply the test to two container surfaces. One container surface is perpendicular to the longitudinal axis of the container and the other container surface is parallel to the longitudinal axis of the container.

A5.5.3.3 Rollover. The container shall be set on its base on the impact surface and tipped slowly sidewise until it falls by its own weight from the base to the side, side to the top, top to the other side and from the other side to the base, thus completing one revolution.

A5.5.3.4 Pendulum impact. The container shall be freely suspended by ropes, chains or cables and swung as a pendulum against the rigid, flat and vertical barrier. The longitudinal axis of the container shall be perpendicular to the barrier and the end shall rest lightly against it. The container shall be pulled back from the barrier until the center of gravity is raised 520 mm (20.5 in) or to the required pendulum angle, so that an impact velocity equal to 3.2 m/s (10.5 ft/s) shall be attained. The container is then released and allowed to swing freely against the barrier. This test shall also be applied to a container surface parallel to the longitudinal axis of the container.

A5.5.3.5 Incline impact test. This test is an alternate to the Pendulum Impact Test. The test shall be conducted in accordance with Procedure A, ASTM-D-880, Incline Impact Test for Shipping Containers, and the container shall project beyond the dolly by a minimum of 50 mm (2 in). The container shall strike the rigid back stop at a velocity of 3.2 m/s (10.5 ft/s). This test shall be applied once each to a container surface perpendicular to the container longitudinal axis and to a container surface parallel to the longitudinal axis.

A5.5.4 Compliance. At the completion of each test procedure at one temperature, remove the fuzes from the package and inspect the fuze and the package for compliance with criteria for passing the test. See A5.3.

A5.6 ALTERNATE AND OPTIONAL TESTS

A5.6.1 Fuzes developed before 18 May 1982. Production specifications for Air Force, Marine Corps or Navy fuzes developed before 18 May 1982 and Army fuzes developed before 15 October 1976 may specify performance of Test 114, later redesignated Test 402. This was a combined vibration and rough handling test.

A5.6.1.1 Vibration. The vibration portion of this test is described as an alternate procedure in Test B1, B1.6.4 and shall be performed in sequence before the drop procedures described in A5.6.1.2.

A5.6.1.2 Free-fall drop. The heights as specified in A5.6.1.2.1 and A5.6.1.2.2 refer to the distance from the concrete surface to the nearest corner. The drop shall be a free fall in that no ropes, cables, guided clamps or cables attached to the lifting crane shall be used to guide the item

during the fall.

A5.6.1.2.1 Packages less than 68 kg (150 lb) total weight with no dimension greater than 1.5 m (60 in). The package shall be dropped free fall 0.9 m (3 ft) onto the rigid horizontal concrete surface 6 times, 1 drop on each of 4 diagonally opposed corners, plus 1 flat drop on bottom, plus 1 flat drop on one end. If the container is cylindrical, the top and bottom is quartered and the above test shall be applied to each of the quartered sections. The sequence of drops shall be as indicated in Figure A5-4.

A5.6.1.2.2 Packages more than 68 kg (150 lb) total weight or having any dimension greater than 1.5 m (60 in). If the physical dimensions of the package preclude the performance of this test as written, the test should be conducted utilizing parameters as close to those specified as possible. The sequence of drops shall be as indicated in Figure A5-5.

- a. **Edgewise drop.** The package shall be supported at one edge of its base on blocks 127 mm (5 in) high and 203 mm by 203 mm (8 in by 8 in) at the base (± 12.7 mm ($\pm 1/2$ in)). The opposite end of the package shall be raised and allowed to drop freely from heights of 0.3, 0.6 and 0.9 m (1, 2 and 3 ft) onto a concrete surface. This test shall be applied to each end of the container. See Figure A5-2.
- b. **Corner drop.** The package shall be supported at one corner of its base on a block 127 mm (5 in) high and 203 mm by 203 mm (8 in by 8 in) at the base (± 12.7 mm ($\pm 1/2$ in)). A block 0.3 m (1 ft) high and 203 mm by 203 mm (8 in by 8 in) at the base (± 12.7 mm ($\pm 1/2$ in)) shall be placed under the other corner of the same end of the package. The opposite end of the package shall be raised and allowed to fall freely from heights of 0.3, 0.6 and 0.9 m (1, 2, and 3 ft) onto a concrete surface. The test shall be repeated on the diagonally opposite corner of the base of the container. See Figure A5-3.
- c. **Rollover.** The package, erect on its base on a hard level floor, shall be tipped slowly sideways until it falls freely, by its own weight from the base to the side, side to the top, top to the other side and from the other side to the base, thus completing one revolution.

A5.6.1.3 Recurring impact. The package shall be vibrated in accordance with Test B1, B1.6.4.3.

A5.6.2 Army fuzes developed between 15 October 1976 and 18 May 1982. Production specifications for Army fuzes developed between these dates may specify performance of Test T120, later redesignated Test 403. This was a combined vibration and rough handling test consisting of a secured vibration test, a rough handling test identical to Test A5 and a loose cargo vibration test. The sequence for compliance with Test T120 is described in Test B1, B1.6.5.

A5.7 RELATED INFORMATION

A5.7.1 Handling shock conditions. This is based on measurements of shock conditions experienced in handling situations throughout the logistical and tactical movement of the packaged fuze from manufacturer to user. Packaged fuzes which are manhandled at load plants, depots and ammunition supply points can result in a number of low energy shocks from drops as high as 0.9 m (3 ft) and, when transferred to ground troops by truck or helicopter, can be dropped from the side of a truck or low hovering helicopter from heights up to 2 m (7 ft).

A5.7.2 Temperature conditions. Temperature conditions are combined with the handling shock conditions to simulate the service use environment. Refer to US Army Regulation 70-38. The temperature levels of -54°C (-65°F) and $+71^{\circ}\text{C}$ ($+160^{\circ}\text{F}$) are the nominal end values encountered and thus used to evaluate the suitability of fuzes to withstand the extremes. The ambient temperature of $+23^{\circ}\text{C}$ ($+73^{\circ}\text{F}$) is considered to be the most probable level of occurrence for the midpoint value.

MIL-STD-331C
w/CHANGE 1
APPENDIX A

A5.7.3 Packaged fuzes. This test is an interface test which is made to assure both the designer of the fuze and the designer of the package that the fuze is protected under the specified environmental conditions of shock and temperature. The test may be performed by the packaging agency or the fuze agency; however, since the fuze is the controlling item, the fuze agency has the final decision of suitability.

A5.7.4 Mechanical shock effects. If the safety condition of the fuzes after the test is in doubt, inspection by radiography is recommended prior to disassembly and inspection. In general, the shock tests can result in internal or external damage to fuzes and damage to packaging material. Distinction between reasonable wear and borderline or serious damage, significant in terms of safety or operability may include studies under dynamic operating conditions where practicable.

A5.7.5 Test severity. Even though the various environmental conditions of this test represent normal handling conditions, the majority of fuzes shall not experience the severity of these combinations. If the container and fuzes pass the tests herein, it is likely that they would survive the logistical and tactical environment.

A5.7.6 Two-meter (7 ft) drop. In general, a single 2 m (7 ft) free-fall drop environment at one temperature is considered within the normal handling conditions for a fuze package issued to ground troops during its life cycle.

A5.7.7 Packaging approved for service use. US Army Regulation 700-15 specifies the service requirements for packaging material. Level A, Maximum Military Protection, is the degree of preservation or packing required for protection of material against the most severe conditions known or anticipated to be encountered during shipment, handling, and storage. Preservation and packing designated Level A is designed to protect material against direct exposure to extremes of climate, terrain, operational and transportation environments. The conditions to be considered include, but are not limited to: (1) multiple handling during transportation and in transit storage from point of origin to ultimate user, (2) shock, vibration and static loading during shipment, (3) loading on shipdeck, transfer at sea, helicopter delivery and offshore or over-the-beach discharge to ultimate user, (4) environmental exposure during shipment or during in-transit operations where port and warehouse facilities are limited or nonexistent, (5) extended open storage in all climatic zones and (6) static loads imposed by stacking.

A5.7.8 Bibliography.

A5.7.8.1 AR 70-38, *Research, Development, Test and Evaluation of Materiel for Extreme Climatic Conditions.*

A5.7.8.2 ITOP 4-2-601, *Drop Tests for Munitions.*

A5.7.8.3 ITOP 4-2-602, *Rough Handling Tests.*

MIL-STD-331C
w/CHANGE 1
APPENDIX A

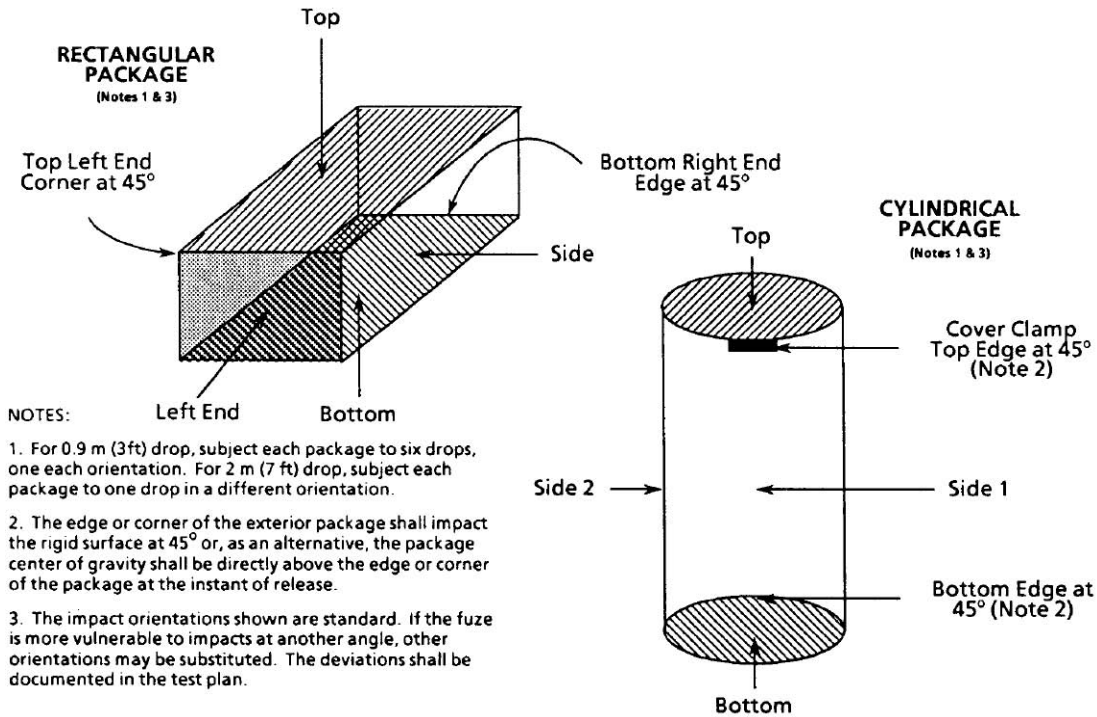

FIGURE A5-1. Free-fall Orientations for 0.9 m (3 ft) and 2 m (7 ft) Drops

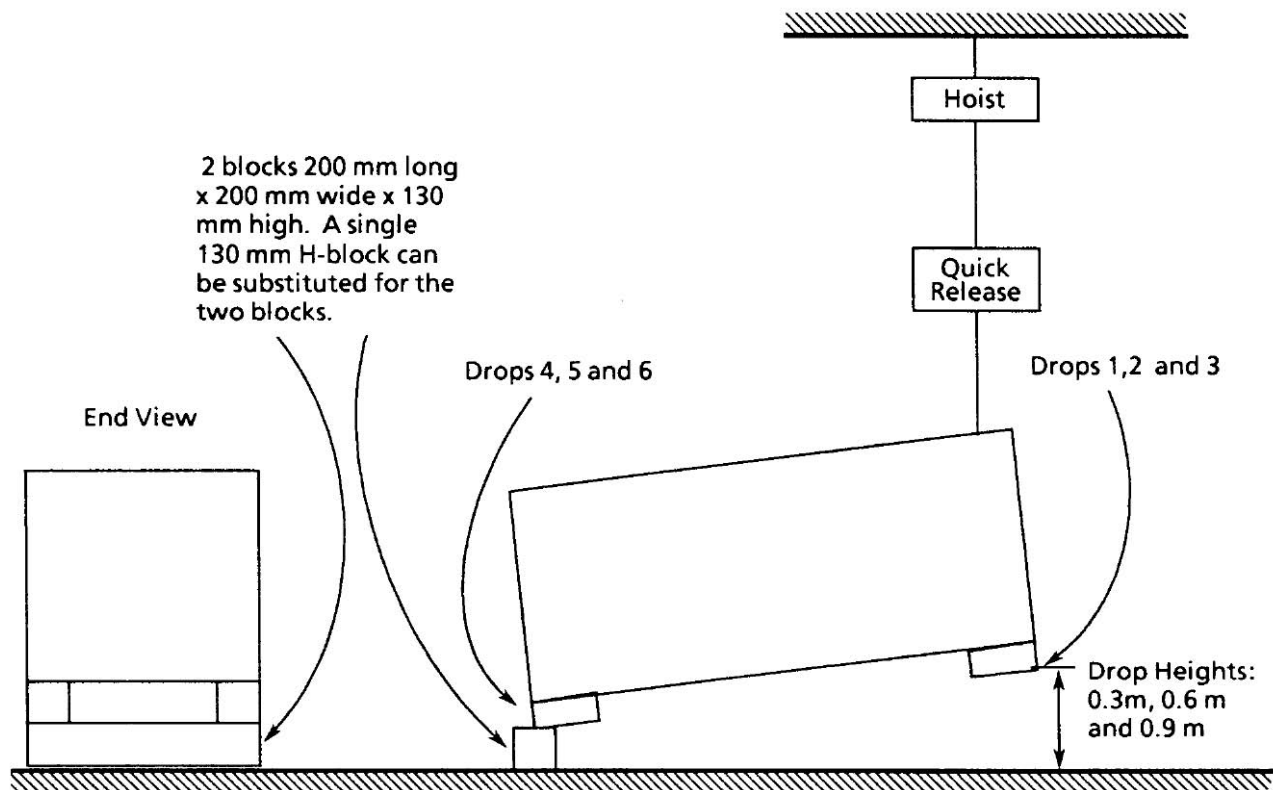

FIGURE A5-2. Edgewise Drop

MIL-STD-331C
w/CHANGE 1
APPENDIX A

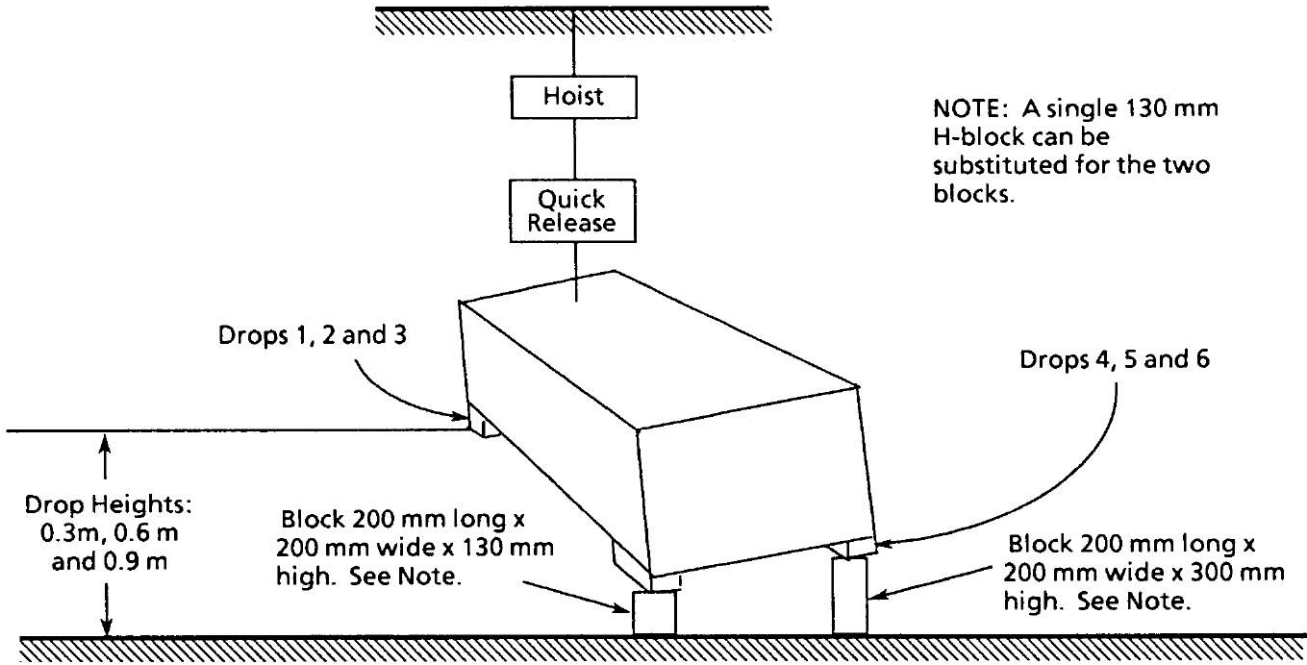

FIGURE A5-3. Cornerwise Drop

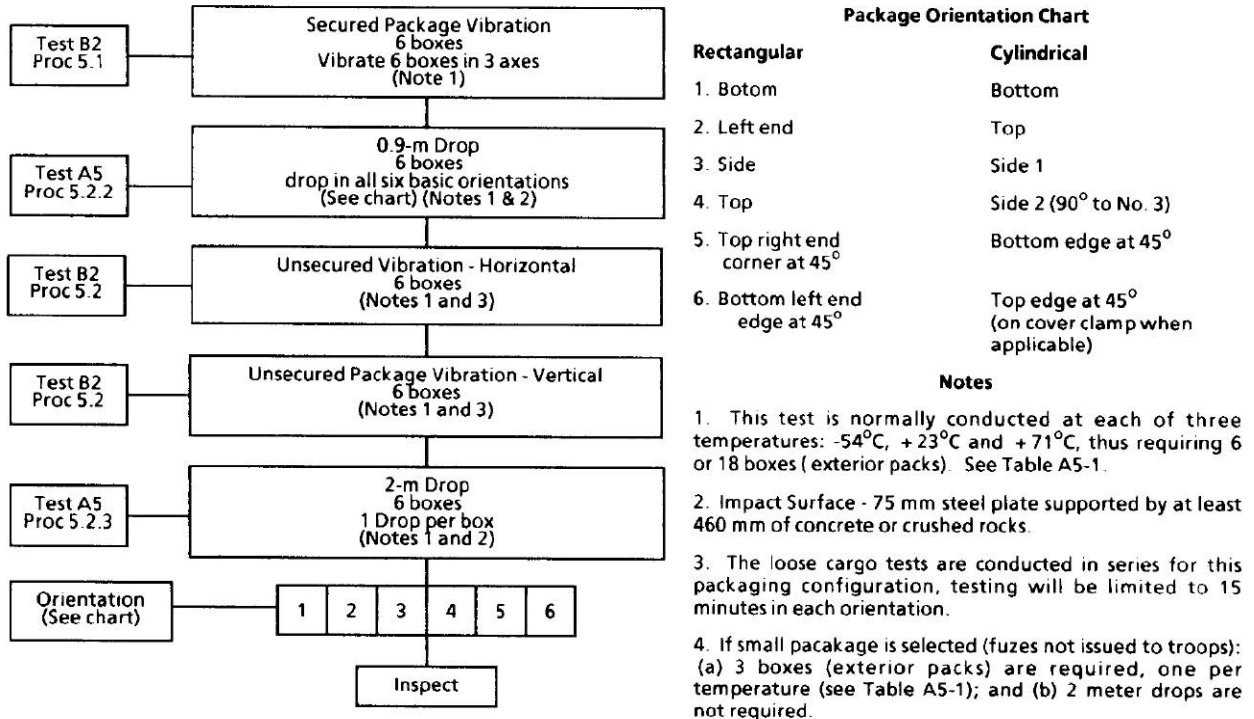
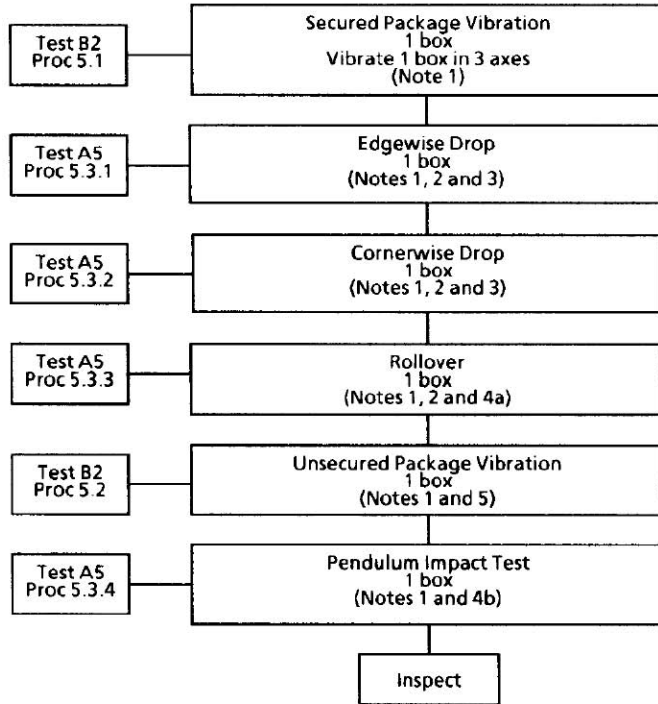

FIGURE A5-4. Typical Sequential Vibration-Handling (Packaged Fuzes) Test For Artillery, Mortar And Recoilless Rifle Ammunition, Cartridges And Fuzes (for exterior packages 68 kg (150 lb) or less)

MIL-STD-331C
w/CHANGE 1
APPENDIX A



Notes

1. This test is normally conducted at each of three temperatures: -54°C, +23°C and +71°C, thus requiring 3 boxes (exterior packs).
2. Impact surface - 75 mm steel plate supported by at least 460 mm of concrete or crushed rocks.
3. Conduct 3 drops (0.3, 0.6 and 0.9 meters) per container end (usually skidded), both ends; or one end and one side of container if there is no specific skid orientation.
4. (a) One complete revolution of container
(b) Impact velocity: 3.2 meters/second (alternative: Incline Impact Test).
5. The loose cargo test shall be conducted in the normal shipping mode (usually on skids) for this packaging configuration; testing shall be 30 minutes.

FIGURE A5-5. Typical Sequential Vibration-Handling (Packaged Fuzes) Test For Artillery, Mortar And Recoilless Rifle Ammunition, Cartridges And Fuzes (for exterior packages more than 68 kg (150 lb))

APPENDIX B
VIBRATION TESTS

TEST B1.1

TRANSPORTATION VIBRATION (Bare and Packaged Fuzes)

B1.1. PURPOSE

The Transportation Vibration test is used during development and production to determine the safety and operability of bare or packaged fuzes. The fuzes are subjected to combined vibration-temperature environments anticipated during their logistical movement by land, air and sea conveyances.

B1.2. DESCRIPTION

B1.2.1 General. The logistical phase of the transportation vibration and counterpart environments begins where the fuzes are manufactured and continues through various intermediate storage and transfer points, terminating with the delivery of the fuzes to the using unit in the field. Vibration testing for the tactical phase simulates environments imposed by the user and is covered by Test B3.

During the transportation phase, fuzes are moved as secured cargo; that is, the fuzes, are packed separately or assembled to ammunition (for example, a mortar round), in the appropriate shipping container and the container is restrained or secured to move with the cargo bed. Figure B1-1 shows a typical logistical scenario for fuzes leaving the point of manufacture and transported to the user.

In this test, fuzes are subjected to combined vibration and temperature conditions for specified periods of time simulating conditions and effects encountered during logistic transportation. Most secured cargo vibration procedures apply random frequency stimuli to the fuzes. Measurements have shown that motion produced by the various transportation platforms encountered throughout the logistic chain is characterized as predominantly random vibration (see B1.7.9).

B1.2.1.1 Bare and packaged fuze tests. This test includes requirements for both bare and packaged fuzes. Vibration tests of bare fuzes is recommended to qualify them prior to the selection or availability of the shipping container, or whenever it is desirable to qualify the fuzes independently of its packaging (see B1.7.2). For the packaged test, fuzes or fuzed rounds in the standard package approved for service are subjected to combined vibration and temperature conditions and effects for specified periods of time. The test applies to packaged fuzes meeting Level A (maximum military protection) packaging classification (see B1.7.3). Test levels and durations for bare and packaged fuzes are identical.

B1.2.1.2 Definitions. The following definitions apply to this test.

Bare Fuze – A fuze, or fuzed test item, without any logistical transportation and/or tactical packaging. MIL-STD-331 defines any fuze individually or instated on the intended unpackaged test item to be a bare fuze.

Packaged Fuze – A fuze, or a fuzed test item, with a transporation package and/or a tactical service package. The package may contain multiple fuzes or test items with installed fuzes.

Mode - The medium of travel; that is, air, land or sea.

Procedure - The set of actions or steps performed to test a fuze delivered by a specific conveyance; for example, the commercial vehicle procedure.

Scenario - The sequence of conveyances used and corresponding typical distances traveled in the

logistical transportation of fuzes. A test scenario consists of one or more procedures.

Test - The procedure or set of procedures forming a complete scenario for either bare or packaged fuzes.

B1.2.2 Secured and loose cargo tests. For packaged fuzes, this test is performed in two parts, as a secured cargo test and as a loose cargo test (see B1.2.2.1 and B1.2.2.2 respectively). For bare fuzes, only the secured cargo test is required.

B1.2.2.1 Secured cargo test. The secured cargo test is required for both bare and packaged fuzes. An important goal for the test activity should be to match the applied vibration stimuli with a given ordnance type and the anticipated transportation scenario. Appropriate vibration schedules are selected from a matrix of procedures which correspond to the ordnance type and the conveyances used to transport the fuzes to the user. This matrix is shown in Table B1-I. There are eight different procedures which cover specific vibration-temperature conditions that could be encountered by the fuzes throughout the logistic phase of a typical, one-time shipment scenario (Figure B1-1).

Figure B1-2 shows the process for selecting secured cargo test procedures. Seven of the eight procedures correspond to different specified land, air and sea conveyances. When the test directive specifies the conveyances and corresponding one-time distances for the fuze, proper selection of these procedures shall avoid overtesting. A typical scenario for Army fuzes would commence with the land mode (Commercial Vehicle Procedure), followed by a sea mode (Cargo Ship Procedure), and terminate with the remaining portions of the land mode (Military Vehicle Procedures). Table B1-II provides the vibration duration and amplitude requirements for the procedures. The test duration for the land transportation mode only (commercial and military vehicles) may be tailored (shortened or lengthened) if the actual transportation distances for the fuzes are specified. The time and distance criteria for tailoring are outlined in B1.5.1.1.3.

The unspecified conveyance procedure (the eighth procedure), provides the most severe vibration test and must be used whenever the transportation scenario is not specified in the test directive or is not known. This special stockpile-to-user test procedure is provided in Table B1-III. The procedures involve the highest vibration amplitudes expected in the logistic phase for a one-way shipment of fuzes.

The eight secured cargo procedures are as follows (refer to Figure B1-1 for further clarification):

- a) **Commercial vehicle procedure.** This procedure applies to the movement of fuzes by commercial land vehicles from the manufacturer's plant to any continental United States (CONUS) storage or user installation. This procedure applies to the transportation of fuzes by rail, truck, trailer and semi-trailer over improved roads.
- b) **Military vehicle procedures.** These procedures apply to the movement of fuzes by military land utility and tactical vehicles from the port staging area or main staging area, through the forward supply area, terminating with the using unit (including the forward unit). There are three procedures to be performed for military vehicles. The procedures apply to the transportation of fuzes by truck, semi-trailer, two-wheeled trailer, and tracked vehicle, over improved and unimproved roads. The tracked vehicle procedure is conducted in five phases.
- c) **Jet aircraft procedure.** This procedure applies to the movement of fuzes by military jet aircraft from any CONUS source to the main staging area outside the continental United States (OCONUS).
- d) **Turboprop aircraft procedure.** This procedure applies to the movement of fuzes by military turboprop aircraft from the main staging area (OCONUS) to the advanced using unit

MIL-STD-331C
w/CHANGE 1
APPENDIX B

(furthest forward unit reachable by turboprop aircraft).

- e) **Helicopter procedure.** This procedure applies to the movement of fuzes by military helicopters from the forward supply area (OCONUS) to the advanced using unit (furthest forward unit reachable by helicopter). This procedure applies to the transportation of fuzes by general purpose and/or utility helicopter (tactical helicopter excluded).
- f) **Cargo ship procedure.** This procedure applies to the movement of fuzes by naval cargo vessels from any CONUS source to any OCONUS source including the port staging area.
- g) **Combat ship procedure.** This procedure applies to the movement of fuzes by naval combat vessels from any CONUS source to any OCONUS source, including the port staging area.
- h) **Unspecified conveyance procedure.** This procedure applies to the overall movement of fuzes from the stockpile or the manufacturer's plant to the advanced user unit OCONUS by conveyances described in B1.2.2.1 (a) through (g). Since the types of conveyances are unknown or undefined, this procedure subjects fuzes to the most severe vibration levels anticipated throughout the logistic phase of transportation.

B1.2.2.2 Loose cargo test. This part of the test only applies to packaged fuzes. The fuze package is placed on the vibration table and is restrained only by a fence which prevents the package from falling off the table.

B1.2.3 Test articles.

B1.2.3.1 Fuzes. The fuzes shall be completely assembled, including all explosive elements which are part of the fuze design. However, inert elements may be substituted for the explosive elements when the presence of explosive elements may pose an excessive hazard to equipment or personnel. The inert elements shall have an equivalent weight and configuration as the elements being replaced. When inert elements are used, the explosive elements shall be separately qualified in the fuze to the vibration requirement.

B1.2.3.2 Fuzed rounds. Fuzes that are normally shipped assembled to the rounds shall be tested assembled to the associated inert loaded rounds (equivalent mass and configuration) or munitions in the packaged configuration. Where applicable, the word "fuze" used throughout this test shall mean "fuzed round".

B1.2.3.3 Packaging. For the packaged fuze test, the standard exterior pack shall be used. When the exterior pack is a bulk pack (more than one fuze) and the quantity of explosive loaded fuzes (ELF) is not sufficient to provide a complete pack, dummy (or inert) fuzes of similar exterior configuration and mass may be used to fill the pack. When dummy (or inert) fuzes are used as fillers, the ELF shall be located so as to be subjected to the most severe test conditions (see B1.7.4 and B1.7.5).

B1.2.4 Documentation. The following details shall be specified in the test directive which uses this vibration test and shall also form a part of the final test report.

B1.2.4.1 Test number and options. Specify this test (B1.1), as well as all of the options under which this test may be performed, including whether the bare or packaged fuze requirements of this test apply. Whenever possible the test directive shall specify the conveyances used to transport the fuzes and the maximum distance traveled in each conveyance.

B1.2.4.2 Fuze operating requirements. Specify fuze performance requirements, parameters, and data, including pre-test data, necessary to conduct a proper evaluation of the compliance of the fuzes with test requirements. In some cases, it may be necessary to validate fuze operating requirements during this test.

B1.2.4.3 Changes. Specify any deviation and rationale in test conditions, procedures, or

fuze configuration. A tailored Commercial Vehicle Procedure or Military Vehicle Procedures (Table B1-I) shall be labeled "Tailored Procedure(s) X" where the symbol X defines the procedure(s) type being tailored; for example, "Tailored Military Vehicle Procedures, Military Tracked Vehicle - Phase 3".

B1.2.4.4 Test records. Specify provisions for recording the required test data (both written and pictorial) to show how this test was performed and the response of the fuze to the test conditions. The required data consists of any information necessary to demonstrate compliance with this test. This information may entail any pertinent combination of structural, mechanical, electrical, chemical, safety, or operational characteristics of the fuze generated in response to the test requirements and conditions.

B1.3. CRITERIA FOR PASSING TEST

B1.3.1 Safe and operable. At the completion of this test, the fuze shall be safe for transportation, storage, handling and use, as well as operable in accordance with 4.6.2.1a and 4.6.2.2 of the general requirements of this standard.

B1.3.2 Decision basis. The decision that the fuze has met or has failed to meet the safety and operability requirements is based upon breakdown, inspection, and completion of the appropriate tests, together with engineering judgment (see B1.7.8).

B1.3.3 Exterior pack damage. Minor damage to the exterior pack or unit package is acceptable. Such damage may include loose nails, split wood, bent box hardware, dents in fiber containers or metal cans, and so forth. The damage resulting from the test must not affect the intended continued use of the packaging. The package must not spill its contents, must be capable of being handled, stacked, and stored as intended, and must not compromise fuze protection. If the package is so damaged, the test must be considered a failure, that is, the package has failed the test.

B1.4. EQUIPMENT

B1.4.1 Equipment for secured cargo test.

B1.4.1.1 Vibration equipment. The vibration equipment shall be capable of producing the tests specified in Table B1-II. Frequency control shall be continuous over the test range. The following frequency and time accuracies shall be applied to control sinusoidal motion: Sweeptime 3% (of the specified duration); frequency ± 0.5 Hz from 5 Hz to 50 Hz and ± 2 Hz from 50 Hz to 500 Hz. Frequency accuracy for control of random vibration shall be maintained to one-half the allowed filter (line) resolution (for example, 5 Hz for a 10-Hz line resolution) from 5 Hz to 2000 Hz. Unless otherwise specified, the duration of the random vibration test shall be limited to $\pm 1\%$ of the specified period. Refer to B1.5.1.5, B1.5.1.6 and Figure B1-3 for control, analysis and further tolerance requirements of sinusoidal and random vibration tests.

B1.4.1.2 Instrumentation. Instrumentation shall be capable of measuring within the prescribed accuracies the frequency, amplitude, and duration of the applied random and sinusoidal vibration and the conditions of temperature specified (see B1.7.6). Fuze vibration response instrumentation shall be used if fuze resonance data or correlation data (between bare and packaged fuze testing) are required. Instrumentation used to acquire fuze performance data shall be capable of measuring parameters within the prescribed amplitudes and accuracies stated in the test plan.

B1.4.1.3 Temperature conditioning equipment. Temperature conditioning equipment shall maintain the packaged fuzes at the specified temperature levels of $+71\pm 2^\circ\text{C}$ ($+160\pm 4^\circ\text{F}$),

+23±10°C (+73±18°F), and -54 ±2°C (-65±4°F) during the test.

B1.4.1.4 Mounting fixture and control accelerometer.

B1.4.1.4.1 Bare fuze tests. Fixtures which simulate the means of attachment of the fuze to the munition shall be used to mount the fuze to the vibration table. The control accelerometer, or accelerometers, shall be mounted as closely as possible to the locations on the fixture where motion is imparted to the fuze (generally the fuze/fixture interface). The fixture shall be designed such that the response motion at any point on the fixture shall be less than twice the input motion measured at the control point; that is, amplification < 2.0. If more than one control accelerometer is used, the amplitude shall be represented by the linear average of the accelerometers involved. The transverse motion at any control point shall be less than 100 percent of the input motion. The fixture shall be evaluated for amplification (response with respect to input at the point of control) and transverse motion, while loaded with fuzes or dummy fuzes of the same configuration and mass, through the range of test frequencies, 5 Hz to F_{max} , where F_{max} represents the highest test frequency (Hz).

B1.4.1.4.2 Packaged fuze tests. The control accelerometer, or accelerometers, shall be mounted as closely as possible to the locations on the test table where controlled motion is imparted to the fuze package (fuze exterior pack). The transverse motion at any input control points shall be less than 100 percent of the input motion over the frequency range of the test. The fuze package shall be securely fastened to the vibration table with caution taken not to damage the package through the fastening mechanism.

B1.4.2 Loose cargo test equipment.

B1.4.2.1 Vibration equipment. The vibration equipment required to conduct this procedure may be the same as that for the secured cargo test, or equivalently may consist of a special loose cargo vibration apparatus that imparts rectilinear harmonic motion, and shall provide the required vibratory input to the fuze exterior pack in accordance with B1.5.2, subject to the following conditions.

B1.4.2.2 Vibration table surface. The mounting surface of the vibration table shall be faced with steel, carbon, cold-rolled, Temper 3 per ASTM-A109, a minimum of 0.06 in (1.5 mm) thick, securely fastened to the vibration table mounting surface. A fence shall be attached to the mounting surface to prevent the fuze exterior pack from falling off the mounting surface. The total free space between the exterior pack and adjacent sides of the fence shall not exceed 2 in (51 mm). Otherwise, the fuze exterior pack shall not be restrained during the test.

B1.4.2.3 Instrumentation. Instrumentation shall be capable of measuring within the prescribed accuracies the frequency and amplitude of the applied sinusoidal vibration and the conditions of temperature specified (see B1.7.6). The fuze may be instrumented if fuze response data or correlation data (comparing fuze response between the secured cargo and loose cargo test) are required.

B1.4.2.4 Temperature conditioning equipment. Same as B1.4.1.3.

B1.5. PROCEDURE

This test consists of a secured cargo vibration (B1.5.1) test and a loose cargo vibration test (B1.5.2). The loose cargo vibration test is only required for packaged fuzes.

B1.5.1 Secured cargo test. The secured cargo vibration test is required for both bare and packaged fuzes.

B1.5.1.1 Procedure selection. Secured cargo vibration procedures, if not specified by the test directive shall be determined from Table B1-I. Selection depends on the type of fuze, and the

transportation modes for that fuze assuming a typical distance traveled in each mode. Fuzes are grouped by their ordnance type. These are listed in the left-hand column of Table B1-I. The remaining columns cover seven specified transportation procedures and an Unspecified Conveyance Procedure, or all-mode case. Use the Unspecified Conveyance Procedure when the transportation modes and distances are not known or have not been specified in the test directive. The Unspecified Conveyance Procedure provides the most severe test. "Yes" or "No" in the table cells indicates whether a given transportation mode is likely to be used for a given ordnance type. A scenario describes transportation modes and associated distances.

Procedures correspond to the one-time, one-way scenario depicted in Figure B1-1 for a typical logistic conveyance. Depending on the specified scenario, more than one test procedure may be required to fully qualify the fuze to meet the requirements, and any procedure may invoke more than one test. Because the individual procedures produce different levels of test severity in the fuze, it is possible to select a set of procedures, including a single procedure, which best qualifies the fuze to the requirement, thereby avoiding irrelevant procedures whose severity is unnecessarily high as compared to the application. For example, a torpedo fuze is not expected to be qualified to track-vehicle vibration.

Select the secured cargo test procedures based on the specified transportation scenario. Figure B1-2 illustrates this selection process. Table B1-II lists the test profile, the test duration and amplitude for each procedure. The vibration test profile for each procedure is described in Figures B1-4 through B1-16.

B1.5.1.1.1 Unspecified conveyance procedure. If the typical one-time transportation scenario is not specified in the test directive, or if the fuze must be qualified to the most severe vibrations that it could encounter during a one-time transportation from the stockpile to the user, the Unspecified Conveyance Procedure shall be selected. The applicable tests and the individual ordnance type are presented in Table B1-III, and the corresponding test requirements are presented in Table B1-II.

B1.5.1.1.2 Specified transportation scenario. If the test directive provides sufficient information to establish the one-time transportation conveyance and distance, the applicable test procedures may be selected using Table B1-II. The more specific the scenario of the test directive, the fewer test procedures that may have to be selected to satisfy test requirements. If the test directive states that the fuze would be transported in all conveyance modes, then all test-procedures applicable to these modes must be selected. For example, an artillery fuze shall generally invoke all land, sea and air procedures. For this condition, the unspecified conveyance procedure must be selected. However, if the test directive of the artillery fuze describes the transportation scenario as consisting of transportation by a commercial vehicle, followed by a cargo-ship, followed by a military tracked vehicle, only those corresponding procedures would be performed in the sequence specified.

It is not necessary to specify or know the actual one-time transportation distance for the individual transportation mode if the typical modes and distances described in Table B-1 and Figure B1-1 satisfy fuze requirements. Note that the test for military tracked vehicles is performed in five phases. All phases must be performed to complete the procedure unless otherwise specified. Table B1-IV provides narrow-band random-on-random test specifications for military tracked vehicles and is used in conjunction with Table B1-II.

B1.5.1.1.3 Tailored transportation scenario. If the test directive specifies non-typical (shorter or longer) transportation distances for the Commercial Vehicle or Military Vehicle Procedures, a tailored test procedure may be performed with a duration corresponding to the

MIL-STD-331C
w/CHANGE 1
APPENDIX B

specified distance. The tailored procedure shall only affect duration, not the test profile shown in Figures B1-4 through B1-11. For this case, the distance and corresponding test time specified in Table B1-II shall provide minutes-per-mile criteria on the basis of which the test time for the tailored procedure may be shortened or extended. For example, a 1500 mile transportation distance shall result in a 90 minute per axis test for the Commercial Vehicle Procedure. A shortened test duration for the tracked Military Vehicle Procedure shall not result in a duration where the number of sweep cycles in any sub-bands is less than one, and for which the number of sweep cycles is not an integer number (partial sweeps not permitted).

B1.5.1.2 Test sample quantities and temperatures. Each test procedure shall be conducted at three temperature levels: $+71\pm 2^{\circ}\text{C}$ ($+160\pm 4^{\circ}\text{F}$), $+23\pm 10^{\circ}\text{C}$ ($+73\pm 18^{\circ}\text{F}$), and $-54\pm 2^{\circ}\text{C}$ ($-65\pm 4^{\circ}\text{F}$). Unless otherwise specified, the fuze or fuze package shall be preconditioned for a minimum of 16 hours to ensure that the entire fuze has reached the specified test temperature level, or until the internal temperature of the fuze has stabilized at the specified level. This can be determined by monitoring interior portions of the fuze or by using predetermined testing or calculation of the thermal response. If monitoring or calculation is used, the fuze temperature shall not vary by more than $\pm 2^{\circ}\text{C}$ ($\pm 4^{\circ}\text{F}$) for 30 minutes prior to the commencement of one test. The temperature of the air or other medium surrounding the fuze or fuze package shall be maintained at the required temperature level to comply with the specified temperature in the fuze for the period of the test.

- a) **Bare fuze test.** Ten (10) fuzes shall be tested at each temperature, requiring a minimum of thirty (30) fuzes.
- b) **Packaged fuze test.** The minimum number of packages which shall be tested at each temperature are as follows:

Package Size	Test Temperature			Total Packages Required (*)
	+160°F (+71°C)	+73±18°F (+23°C)	65±4°F (-54°C)	
Small packages (fuzes not issued to ground troops)	1	1	1	3
Small packages (fuzes issued to ground troops)	6	6	6	18
(If package contains more than 6 fuzes and the required fuzes are not available)	(2)	(2)	(2)	(6)
Large packages (bulk fuzes)	1	1	1	3

(*) each package shall contain at least one (1) fuze which reflects the configuration described in B1.2.3.1.

B1.5.1.3 Vibration levels. Table B1-II describes different levels of vibration for the applicable random, sinusoidal, combined narrow-band random with wide-band random, and combined sinusoidal-with-random vibration tests. The specified level shall be imparted to the bare

fuze through its attachment points to the test fixture (B1.4.1.4.1). For the packaged fuze test, special care must be exercised at the attachment points to assure effective coupling between the package and the test fixture so that the required vibration level is transmitted to the package over the test frequency range (B1.4.1.4.2).

B1.5.1.4 Test fuze orientation.

B1.5.1.4.1 Uniaxis method. The vibration levels specified for the individual test profile in Table B1-II shall be applied to each of the three mutually perpendicular axes of the test fuze or fuze package in turn, unless otherwise specified. These axes shall be established in accordance with the test directive. B1.5.1.5 through B1.5.1.7 apply to the uniaxis method.

B1.5.1.4.2 Triaxis method. The triaxis test method which imparts vibration to the fuze or fuze package in three mutually perpendicular axes simultaneously, is an acceptable alternative to the uniaxis method. The triaxis method reduces test time by 67% and is considered more representative of the fuze or fuze package service environments. The enhanced test may lead to improved fuzed reliability and safety because of the methods' ability to excite potential damage mechanisms in the fuze that may not induced by the uniaxial method. This alternative applies only to random vibration test requirements. Paragraph B1.5.1.8 applies to the triaxis random vibration method.

B1.5.1.5 Sinusoidal vibration (combat ship procedure only). The test requirements in Table B1-II apply. The acceleration levels or displacement amplitudes for the given test profile shall be maintained as vibratory input to the test item through the test item mounting points. When the input vibration is measured at more than one control point, the control signal shall be the average of all the control accelerometers' amplitudes unless otherwise specified. For massive test items and fixtures and for all large-force exciters, it is recommended that the input control level be the average of at least three inputs.

Amplitude control of sinusoidal vibration shall be in accordance with the specification for the applicable test-profile.

WARNING: Resonance search and dwell operations prescribed for the Combat Ship Procedure (B1.5.1.5.1 and B1.5.1.5.2) may cause a buildup of energy within the fuze sufficient to create a hazard of initiation with some explosive components. If the required test level will cause initiation, the fuze shall be considered as having failed this procedure.

B1.5.1.5.1 Resonance search (Combat Ship Procedure only). To determine the presence of resonances in the fuze or fuze package under test, the fuze or fuze package shall be secured to the test fixture and vibrated at frequencies from 5 Hz (or lowest attainable frequency) to 33 Hz, at a table vibratory single amplitude of 0.010 ± 0.0002 inch. For frequencies from 34 Hz to 50 Hz, a table amplitude of 0.003 plus zero, minus 0.0001 inch shall be used. The change in frequency shall be made in discrete frequency intervals of 1 Hz and maintained at each frequency for about 15 seconds. The frequencies and locations at which resonances occur shall be noted. Generally a gain higher than 200 percent (with respect to input motion) constitutes a resonance condition.

B1.5.1.5.2 Resonance dwell (Combat Ship Procedure only). The fuze or fuze package shall be vibrated along each of its test axes at the most severe resonance frequencies established in B1.5.1.5.1 as determined by the test engineer. Test levels, frequency ranges, and test time shall be in accordance with the dwell requirement for the Combat Ship procedure (Table B1-II). If more than four significant resonance frequencies are found for any one axis, the four most severe points (usually those with highest amplification of input) shall be chosen for the dwell test. If no resonance is observed, the test shall be performed at 50 Hz. If a change in the resonance

frequency point occurs during the test, its time of occurrence shall be recorded immediately and the frequency shall be adjusted to maintain the peak resonance condition. The final resonance frequency shall be recorded.

NOTE: A change in resonance frequency may indicate a damaged test item. Before adjusting the resonance frequency, it may be prudent to investigate the condition of the test item.

B1.5.1.6 Random vibration (commercial vehicles, military vehicles, jet aircraft, turboprop aircraft and cargo ship procedures). The vibration shall be applied sequentially along each of the three mutually perpendicular axes of the fuze or fuze package. Alternatively, a triaxis test may be performed per B1.5.1.8. The test profile and test time applicable to the given procedure are listed in Table B1-II. The instantaneous random vibration acceleration peaks may be limited to three times the rms acceleration level. The power spectral density of the test control spectrum shall not deviate from the specified requirement by more than +100, -50 percent (± 3 dB) over the entire test frequency range except that deviations as large as +300, -75 percent (± 6 dB) may be allowed over a cumulative bandwidth of 100 Hz maximum, between 500 Hz and 2000 Hz (Figure B1-3).

Tolerance levels in terms of dB are defined as:

$$dB = 10 \log_{10} \frac{W_1}{W_0}$$

where W_1 is the measured acceleration power spectral density profile expressed in units of G^2/Hz , and W_0 is the specified power spectral density profile also expressed in units of G^2/Hz .

Confirmation of these tolerances shall be made by use of any analysis system providing statistical accuracies corresponding to a bandwidth-time constant product, $BT = 50$, minimum (100 statistical degrees of freedom). Specific analyzer characteristics shall be as specified below or equivalent, subject to the $BT = 50$, $T = 1$ minimum limitation (shortest true averaging time of 1 second).

a. On-line contiguous filter, equalization/analysis system having a bandwidth as follows:

- (1) $B = 25$ Hz, maximum between 20 Hz to 200 Hz
- (2) $B = 50$ Hz, maximum between 200 Hz to 1000 Hz
- (3) $B = 100$ Hz, maximum between 1000 Hz to 2000 Hz

b. Swept frequency analysis systems characterized as follows:

(1) Constant bandwidth analyzer.

(a) Filter bandwidth as follows:

- 1 $B = 25$ Hz, maximum between 20 Hz to 200 Hz
- 2 $B = 50$ Hz, maximum between 200 Hz to 1000 Hz
- 3 $B = 100$ Hz, maximum between 1000 Hz to 2000 Hz

(b) Analyzer averaging time = $T = 2 RC = 1$ second, minimum, where $T =$ True averaging time and $RC =$ analyzer time constant.

(c) Analysis sweep rate (linear) = $SR_L = B/4RC$ or $B^2/8$ ($Hz/second$) maximum, whichever is smaller.

(2) Constant percentage bandwidth analyzer.

(a) Filter bandwidth = $pf_c =$ one-tenth of center frequency maximum ($0.1 f_c$), where $p =$ percentage and $f_c =$ analyzer center frequency.

(b) Analyzer averaging time = $T = 50/pf_c$ minimum.

(c) Analysis sweep rate (logarithmic) = $SR_G = pf_c/4RC$ or $(pf_c)^2/8(\text{Hz/second})$ maximum, whichever is smaller.

- c. The digital power spectral density analysis system employs quantization techniques providing accuracies equal to or higher than those obtained from the above techniques. Digital analysis of random vibration is preferred over analog results. Digital techniques used in this test shall have filter resolution less than or equal to 10 Hz over the entire test frequency range. Accelerometers employed for test level control shall be mounted in accordance with B1.4.1.4. Where more than one accelerometer is employed for test level control, the arithmetic average of the power spectral densities indicated by the control accelerometers shall be used for control of the test level.

B1.5.1.7 Combined sinusoidal and random vibration (Helicopter procedure only).

This is a special test which combines broadband random vibrations with superimposed dominant sinusoidal vibration peaks to simulate helicopter vibration environments. The broadband spectrum is principally generated from the helicopters' powerplant machinery whereas the rotating components, such as the main and rear rotors, generate the fundamental frequency and its harmonics. Different helicopter platforms, fuze stowing locations, and flight profiles will produce different spectra and harmonic components. The Helicopter procedure provides worst case vibration for a utility helicopter likely to be used to transport fuzes. The random vibration spectrum of the test is treated as any other random vibration test per B1.5.1.6, whereas the sinusoidal components are individually controlled to $\pm 10\%$ of the specified amplitude at the designated frequency. The overall rms acceleration is obtained from the superposition of the random and sinusoidal root-mean-square amplitudes.

B1.5.1.8 Specification of Triaxis Random Vibration Test. Let: X, Y, Z describe a right-handed mutually perpendicular coordinate system that may be used to represent the fuze or fuze package axes. For an artillery fuze it is convenient to select the Z-axis as the longitudinal axis of the fuze (axis pointed from base to ogive or nose). Vibration energy is imparted simultaneously to the fuze along the X, Y, Z axis via the fixture that is mounted on the test platform. The test-platform integrates the uniaxial motions into a spatial motion. This spatial motion is characterized by a resultant vector whose magnitude and direction (with respect to the defined coordinate system) may vary continually as a function of test time for all frequencies specified in the test-spectrum. These variations are dictated by the relative amplitudes and phases among the input axes (X, Y, Z). The resultant vector is bounded by a solid envelope (for example sphere, ellipsoid, etc.) which describes the vector's trajectory. Thus vibration energy may be imparted to the fuze in a manner representative of its service vibrations which is generally multiaxial.

The triaxis test may be specified on the basis of the measured service vibration representative of the specific application, or by invoking the conventional uniaxis acceleration power spectral density terms with additional parameters to affect simultaneity as described below. Let

$W_{xx}(f)$ - auto power spectral density (PSD) profile for the X axis, expressed in units of G^2/Hz .
This is a real term.

$W_{yy}(f)$ - auto power spectral density (PSD) profile for the Y axis, expressed in units of G^2/Hz .
This is a real term.

$W_{zz}(f)$ - auto power spectral density (PSD) profile for the Z axis, expressed in the units of G^2/Hz . This is a real term.

MIL-STD-331C
w/CHANGE 1
APPENDIX B

$W_{xy}(f)$ - cross power spectral density (cross-spectrum) profile between the X and Y axes. This is a complex term (contains complex numbers).

$W_{yz}(f)$ - cross power spectral density (cross-spectrum) profile between the Y and Z axes. This is a complex term (contains complex numbers).

$W_{xz}(f)$ - cross power spectral density (cross-spectrum) profile between the X and Z axes. This is a complex term (contains complex numbers).

F - test frequency in units of Hertz.

For control simplicity and to facilitate implementation on existing digital control systems, the complex terms (cross-power spectral density profiles) may be considered complex-conjugate of each other, denoted by (*). Expressing any such term as function of frequency yields

$$W_{xy}(f) = |W_{xy}(f)| \exp [j_{xy}^{\alpha}(f)], \text{ and}$$

$$W_{yx}(f) = W_{xy}^*(f) = |W_{xy}(f)| \exp [-j_{xy}^{\alpha}(f)]$$

Where:

\exp = based of Napier logarithm, equals to 2.3036

$$j = \sqrt{-1}$$

α_{xy} = inter axis phase angle (between x and y axis in example); expressed in radians; the range of the angle is between 0° and 180° .

$|W_{xy}(f)|$ = absolute value (magnitude) of $W_{xy}(f)$, obtained from the knowledge of the axial

acceleration power spectral density profiles and the coherence relationships, γ^2 involving the test axes of interest. For the example shown above this magnitude is given as;

$$|W_{xy}(f)| = \gamma_{xy}(f) \sqrt{W_{xx}(f) \cdot W_{yy}(f)},$$

$$0.0 \leq \gamma_{xy} \leq 1.0$$

Using the terms described above it is now possible to specify the spatial power-spectral-density-matrix, $W_{xyz}(f)$, which defines and controls the triaxis test. Note that $W_{xyz}(f)$ is a Hermitian matrix, as the off diagonal terms represent complex conjugate pairs.

$$W_{xyz}(f) = \begin{bmatrix} W_{xx}(f) & W_{yx}(f) & W_{zx}(f) \\ W_{xy}(f) & W_{yy}(f) & W_{zy}(f) \\ W_{xz}(f) & W_{yz}(f) & W_{zz}(f) \end{bmatrix}$$

Though this procedure seems somewhat involved, in reality all test parameters are known or can be calculated by the test engineer prior to the test. So programming the test equipment to perform a triaxis test is a similar procedure to that which governs the uniaxial test except for the limited number of additional test parameters that shall be furnished by the test-engineer. The programming session is done interactively with the control system which would not allow invalid entries. The required test parameters are extracted from the test data (field measurements). Data analysis is performed in a manner similar to that used to extract the acceleration power spectral density profiles for the uniaxial test. The additional parameters necessary to define the triaxis test, such as cross spectral density profiles and phases information, are calculated from the same raw

MIL-STD-331C
w/CHANGE 1
APPENDIX B

data set from which the auto-spectral density profiles (uniaxis PSDs) are derived. In the absence of field measurements and given the acceleration power spectral density profiles for the uniaxis test, a triaxis test can be defined by setting the coherence value equal to zero. This condition will result in random interaxis phases at all frequencies. For this test condition the fuzes or fuze package would be subjected to a uniform distribution of random vibration amplitudes for all test frequencies in all possible directions with respect to the origin of the coordinate system selected for the test (usually coincidental with the control accelerometers). The resulting spatial vibration would be similar to that experienced by the fuzes in the actual transportation platform for which no correlations exist between the individual axes that provide excitation to the fuzes. Tolerances for the auto power spectral density (PSD) profiles, when used in a triaxis test, are the same as those specified for the uniaxis method (see B1.5.1.5 through B1.5.1.7). No tolerances are placed on the spatial power spectral density matrix $[W_{xyz}(f)]$, the cross spectrum, and the coherence terms.

NOTE: Generally, phase and coherence values can not be specified independently so as not to create a physically unrealizable test condition. The spatial power spectral density matrix, $W_{xyz}(f)$, needs to be a Hermitian and positive semi-definite quantity if it were to represent a physical triaxis stochastic process. This constraint implies that;

(a) $W_{yx}(f) = W_{xy}(f)$,
 $\det [W_{xyz}(f)] \geq 0$ and

(b) resulting in the following interdependent relationships between phase and coherence after proper substitutions;

$$\det [W_{xyz}(f)] = W_{xx}(f) W_{yy}(f) W_{zz}(f) \{ (1 - \gamma_{yz}^2 - \gamma_{xy}^2 - \gamma_{xz}^2 + 2 \gamma_{xy}(f) \gamma_{yz}(f) \gamma_{xz}(f) \cdot \cos[\alpha_{xy}(f) + \alpha_{yz}(f) - \alpha_{xz}(f)] \} \geq 0$$

For a fully coherent case ($\gamma_s = 1$), this constraint imposes restriction on the phase relationship;

$$\alpha_{xy}(f) + \alpha_{yz}(f) - \alpha_{xz}(f) = 0$$

that is, any one phase would depend on the other two.

For a fully non-coherent case ($\gamma_s = 0$) the phase can assume any value. This condition allows for random interaxis phase to exist, leading to variation of magnitude and spacial direction of the resultant vector. As a result, uniformly distributed spatial vibratory energy would be imparted to the fuze.

B1.5.1.9 Fuze and package inspection. Upon completion of the vibration test procedures, the fuzes and fuze packages shall be removed from the fixture and examined for conformance with the criteria for passing the test (see B1.3).

B1.5.2 Loose cargo vibration. This procedure is only required for packaged fuzes.

B1.5.2.1 Test sample quantities and temperatures. Three temperature conditions are required for the complete test: $+71 \pm 2^\circ\text{C}$ ($+160 \pm 4^\circ\text{F}$), $+23 \pm 10^\circ\text{C}$ ($+73 \pm 18^\circ\text{F}$), and $-54 \pm 2^\circ\text{C}$ ($-65 \pm 4^\circ\text{F}$). Unless otherwise specified, three packages (or eighteen, see B1.5.1.2) of fuzes are required as a minimum, one (or six) for each temperature condition. Each fuze package shall be temperature conditioned for either a minimum of 16 hours or until the temperature of the fuze has stabilized at the specified level. The packaged fuzes shall be maintained at that temperature level

MIL-STD-331C
w/CHANGE 1
APPENDIX B

for the duration of the test. Temperature stabilization shall be in accordance with the provisions described in B1.5.1.2.

B1.5.2.2 Sinusoidal vibration. The fuze package shall be placed on the steel mounting surface (table) of the vibration equipment. The fuze package shall not be restrained during vibration, except by a fence attached to the test surface. The fence shall prevent the package from falling off the table. Rectangular packages shall be tested for 15 minutes +1 minute on each of the most vulnerable horizontal and vertical faces on the same package (two faces total). Cylindrical-type containers shall be tested for 15 minutes +1 minute on the bottom face (or top, if more vulnerable) and 15 minutes +1 minute at the most vulnerable circumferential position. The cylindrical container shall be allowed to rotate circumferentially during the test. The vibratory frequency shall be 5 Hz and the vibratory surface shall have a 25-mm (+1-in) +2.5-mm (+0.1-in) vertical displacement (peak to peak). Total test time shall be 30 minutes for each type package.

B1.5.2.3 Fuze inspection. Upon completion of the vibration test procedure, the fuzes (removed from the package) and the packages shall be inspected for conformance to the criteria for passing the test (see B1.3).

B1.6 ALTERNATE AND OPTIONAL TESTS

B1.6.1 General information.

B1.6.1.1 Application. B1.1 through B1.5 constitute the standard transportation vibration test for all fuzes. Since older fuzes which were formerly tested to sinusoidal schedules are now subjected to transportation environments represented by the standard test, they are considered qualified to the standard random vibration test. Requirements in effect at the time older fuzes were developed may be applied as an alternate test. Determine the period of development for the fuze or the MIL-STD-331 test number called out in the test directive, and perform procedures as follows.

Fuze Development Period	Fuze Config.	Former Test No.	Test B1 Procedure	Remarks
5/18/82 - 1/1/97	Bare and packaged	123, 124, B1, B2	B1.6.2	
11/1/73 - 5/18/82	Bare	119-II, 404	B1.6.2	Rm. temp. only
Before 11/1/73	Bare	104, 401	B1.6.3	
Before 5/18/82	Packaged	114, 402	B1.6.4	Includes rough handling
10/15/76 - 5/18/82 (Army only)	Packaged	T120, 403	B1.6.5	Includes rough handling

B1.6.1.2 Compliance. Upon completion of the appropriate alternate test, the fuzes shall comply with the requirements of B1.3.

B1.6.1.3 Equipment. Specifications for vibration equipment, temperature conditioning equipment and test instrumentation are given in Section B1.4.

MIL-STD-331C
w/CHANGE 1
APPENDIX B

B1.6.2 Former Test 119 (404), 123, 124, B1 and B2 procedure. Note: Test 119, Procedure I was intended for fuzes in development. Essentially, it doubled the test duration and provided for testing fuzes at extreme temperatures. Test 119, Procedure II is identical with Tests 123 and 124 (secured vibration), except it is only performed at room temperature.

B1.6.2.1 Secured cargo vibration. This test is required for bare and packaged fuzes.

a. **Temperature conditioning.** Precondition the number of bare or packaged fuzes specified by B1.5.1.2 to -54°C (-65°F), +23°C (+73°F) and +71°C (+160°F) for 16 hours minimum. Immediately after the appropriate number of test articles have been preconditioned, perform the test described below. The test articles shall be maintained at the temperature level for the duration of the test. Bare fuzes complying with former Test 119 (404) shall only be vibrated at room temperature.

Frequency (Hz)	Displacement and Acceleration Levels
5 - 11	10 mm (0.39 in) displacement, peak-to-peak
11 - 37	2.5 g acceleration, peak
37 - 52	0.9 mm (0.04 in) displacement, peak-to-peak
52 - 500	5.0 g acceleration, peak

B1.6.2.2 Loose cargo vibration. This test is only performed on packaged fuzes.

a. **Temperature conditions.** The requirements of B1.6.2.1a. shall apply except, perform the test described in B1.6.2.2b.

b. **Vibration conditions.** The fuze package shall be placed on the steel mounting surface (table) of the vibration equipment. The fuze package shall not be restrained during vibration. Rectangular packages shall be tested for 15±1 minutes on each of the most vulnerable horizontal and vertical faces on the same package (two faces total). Cylindrical type containers shall be tested for 15±1 minutes on the bottom face (or top, if more vulnerable) and 15±1 minutes on the most vulnerable circumferential position. The cylindrical container shall be allowed to shift circumferentially during the test. The vibratory frequency shall be 5 Hz, and the vibratory surface shall have a 25 mm (1 in) vertical displacement (peak-to-peak). Total test time shall be 30 minutes for each type of package.

B1.6.3 Former Test 104 (401) procedure. Procedure I (B1.6.3.1, below) provides a vibration schedule of 10 Hz to 500 Hz for 24 hours; and Procedure II (B1.6.3.2) a vibration schedule of 10 Hz to 60 Hz for a total test duration of 12 hours. Effective procurement specifications should be consulted to determine the appropriate procedure for specific fuzes. Each of these procedures provides a sweep method and discrete step method. The bare fuze shall be securely fastened to the vibration table and excitation applied parallel to each of three major axes in turn,

- a. the longitudinal axis (line of flight),
- b. a first transverse orthogonal axis, and
- c. a second transverse orthogonal axis.

MIL-STD-331C
w/CHANGE 1
APPENDIX B

The two transverse axes and the sense of the vibration (nose up or down) along the longitudinal axis shall be chosen to expose the most critical or vulnerable positions of the fuze to the vibration.

B1.6.3.1 Procedure I – 10 Hz to 500 Hz – 24-hour schedule. This test was formerly Test 104, Procedure I, later redesignated Test 401. A minimum of three fuzes are required; one fuze each shall be preconditioned to $-54\pm 2^{\circ}\text{C}$ ($-65\pm 4^{\circ}\text{F}$), $+30\pm 10^{\circ}\text{C}$ ($+86\pm 18^{\circ}\text{F}$) and $+71\pm 2^{\circ}\text{C}$ ($+160\pm 4^{\circ}\text{F}$) and vibrated at one temperature only.

B1.6.3.1.1 Sweep method. Frequency shall be controlled by logarithmic sweep. Total test duration shall be 24 hours plus the time spent at resonant frequencies. Determine the resonant frequencies during the first cycling period for each axis position. When resonant conditions are not observed within the specified vibration schedule given in the table below, perform four additional sweeps, two over the 10 Hz to 60 Hz to 10 Hz range and two over the 60 Hz to 500 Hz to 60 Hz range, 15 minutes each, totaling 60 minutes. Duration at each sweep cycle and at the resonant frequency shall be 20 minutes. The total cycling test time in each axis shall be 8 hours and the test time at resonant points shall be 20 minutes times the number of resonant frequencies.

Type	Frequency (Hz)	Input Amplitude	Cycles
Sweep	10 to 60 to 10	2.54 ± 0.254 mm (0.10 ± 0.01 in) double amplitude or 2 ± 0.2 g peak, whichever is less	10
Sweep	60 to 500 to 60	5 ± 0.5 g peak	14
Resonance	Single frequency points determined from first sweep	As indicated above in specific frequency range	Depends on the number of resonant points

B1.6.3.1.2 Discrete step method. The vibration schedule below shall be used. Total test duration shall be 24 hours plus the time spent at resonant frequencies. The resonant frequencies may occur between the frequency steps and additional investigation will be necessary to determine whether resonant conditions exist. Intermediate frequency points may be studied to identify either resonant points or resonant bands. The fuze shall then be vibrated at each fixed point or within each resonant band for 15 minutes. When resonant conditions are not observed within the discrete frequency vibration schedule, the resonant vibration shall consist of repeating vibration at four frequency steps, 10 Hz, 46 Hz, 152 Hz, and 500 Hz for 15 minutes at each frequency.

a. Vibration Amplitude.

1. Input amplitude shall be 2.54 ± 0.254 mm (0.10 ± 0.01 in) double amplitude or 2 ± 0.2 g peak, whichever is lesser, for frequencies below 60 Hz.

MIL-STD-331C
w/CHANGE 1
APPENDIX B

2. Input amplitude shall be 5 ± 0.5 g peak for frequencies above 60 Hz.
- b. Duration.
1. Duration at steps 1 to 8 (fixed frequency) per axis shall be 60 minutes per step.
 2. Duration at step 9 per axis shall be 15 minutes per resonant frequency.

Step	Longitudinal Axis	Transverse 1 Axis	Transverse 2 Axis
1	10	12	14
2	17	20	24
3	28	33	38
4	46	54	65
5	76	91	107
6	128	152	178
7	212	250	297
8	350	417	500
9	Resonant frequency as determined		

B1.6.3.2 Procedure II – 10 to 60 Hertz – 12-hour method. This test was formerly Test 104, Procedure II later redesignated Test 401.

B1.6.3.2.1 Sweep method. The frequency range from 10 Hz to 60 Hz to 10 Hz shall be covered by cycling at a logarithmic rate. Fifteen (15) minutes shall be allowed for each 10 Hz to 60 Hz to 10 Hz sweep. A total of 16 sweeps are to be made in each of the three axes. Time of test for each axis shall be 4 hours to give a total test duration of 12 hours.

B1.6.3.2.2 Discrete step method. The frequency range from 10 Hz to 60 Hz +3% shall be covered using 24 discrete frequency steps in a logarithmic distribution. The time shall be 10 minutes at each step in each of the three axes. The steps are shown below. Time of test for each axis shall be 4 hours to give a total test duration of 12 hours. The vibration amplitude shall be maintained at 2.54 ± 0.254 mm (0.10 ± 0.01 in) double amplitude up to and including 20 Hz (Step 10) and at 2 ± 0.2 g peak for the remaining frequency coverage (steps 11 through 24).

Step	Freq (Hz)	Step	Freq (Hz)	Step	Freq (Hz)
1	10	9	18	17	35
2	11	10	20	18	38
3	12	11	22	19	41
4	13	12	24	20	44
5	14	13	26	21	47
6	15	14	28	22	51

MIL-STD-331C
w/CHANGE 1
APPENDIX B

7	16	15	30	23	55
8	17	16	32	24	60

B1.6.4 Former Test 114 (402) procedure. Production specifications for Air Force, Marine Corps or Navy fuzes developed before 18 May 1982 and Army fuzes developed before 15 October 1976 may specify performance of Test 114, later redesignated Test 402. This was a combined vibration and rough handling test. The free fall drop and recurring impact portions of this test are described in B1.6.4.2 and B1.6.4.3 respectively, and shall be performed in sequence following the vibration procedure described in B1.6.4. 1. Any vibration testing machine capable of meeting the conditions specified below may be used. Unless otherwise specified by the test directive, the test shall only be conducted at ambient temperature and the sequence of testing shall be vibration, free-fall drop and recurring impact respectively.

B1.6.4.1 Vibration 5 Hz thru 500 Hz. The package shall be securely fastened to the vibration table. Vibratory excitation shall be applied parallel to each of three orthogonal axes of the container for equal periods of time using the method of B1.6.4.1.1 or B1.6.4.1.2, depending upon the equipment type. The axes shall be selected to simulate the orientations of normal transportation. Monitor or observe for resonant frequencies. When resonance is not observed, the portion of the test from 5 Hz to 60 Hz shall be performed two additional times.

B1.6.4.1.1 Cycling method. The vibration schedule below shall be used. The specified durations refer to one axis of vibration. Frequency shall be varied by logarithmic sweep.

Type	Frequency (Hz)	Input Amplitude (peak-to-peak)	Duration (min)
Cycling	5-10-5	3.3 mm (0.13 in)	11
Cycling	11-20-11	2.3 mm (.09in)	11
Cycling	21-60-21	1.5 mm (0.06 in)	18
Cycling	61-500-61	±10 g peak (vector)	34
Resonance	As determined	As indicated above	15

B1.6.4.1.2 Discrete step method. The vibration schedule below shall be used. The specified duration refers to one axis of vibration. The major resonant frequency may occur between the frequency steps and additional investigation will be necessary in order to determine this. Intermediate frequency points may be studied to identify either resonant points or resonant bands.

Step	Frequency (Hz)	Input Amplitude (min)	Duration
1	5	3.3 mm (0.13 in) peak-to-peak	2 min 22 s

MIL-STD-331C
w/CHANGE 1
APPENDIX B

2	6	3.3 mm (0.13 in) peak-to-peak	2 min 22 s
3	8	3.3 mm (0.13 in) peak-to-peak	2 min 22 s
4	10	3.3 mm (0.13 in) peak-to-peak	2 min 22 s
5	12	2.3 mm (0.09 in) peak-to-peak	2 min 22 s
6	14	2.3 mm (0.09 in) peak-to-peak	2 min 22 s
7	17	2.3 mm (0.09 in) peak-to-peak	2 min 22 s
8	20	2.3 mm (0.09 in) peak-to-peak	2 min 22 s
9	24	1.5 mm (0.06 in) peak-to-peak	2 min 22 s
10	28	1.5 mm (0.06 in) peak-to-peak	2 min 22 s
11	33	1.5 mm (0.06 in) peak-to-peak	2 min 22 s
12	39	1.5 mm (0.06 in) peak-to-peak	2 min 22 s
13	46	1.5 mm (0.06 in) peak-to-peak	2 min 22 s
14	54	1.5 mm (0.06 in) peak-to-peak	2 min 22 s
15	65	± 10 g peak	2 min 22 s
16	76	± 10 g peak	2 min 22 s
17	91	± 10 g peak	2 min 22 s
18	107	± 10 g peak	2 min 22 s
19	128	± 10 g peak	2 min 22 s
20	152	± 10 g peak	2 min 22 s
21	178	± 10 g peak	2 min 22 s
22	212	± 10 g peak	2 min 22 s
23	250	± 10 g peak	2 min 22 s
24	297	± 10 g peak	2 min 22 s
25	350	± 10 g peak	2 min 22 s
26	417	± 10 g peak	2 min 22 s
27	500	± 10 g peak	2 min 22 s

MIL-STD-331C
w/CHANGE 1
APPENDIX B

28	Resonant frequency	As indicated above	15 min
----	--------------------	--------------------	--------

B1.6.4.2 Drop tests. Drop tests shall be performed as described in Test A5, A5.6.1.

B1.6.4.3 Recurring impact. The package shall be placed on the mounting surface of the vibration machine. If this surface is not wood, a wooden platform shall be rigidly attached to the mounting surface. A fence may be attached to the test table to prevent the item from falling off the table, otherwise the package is not restrained. Oblong packages shall be tested for five minutes on each of the six faces. Drum type containers shall be tested for 5 minutes each on the top and bottom and for 20 minutes circumferentially. If the cylinder does not shift circumferentially during the test, it shall be shifted manually. If the cylinder is so loaded that it continually returns to the same circumferential position, the test shall be run to its completion in that position. Total time required to perform test is 30 minutes. The mounting platform shall have essentially circular motion in the vertical plane of 25.4 mm (1 in) peak-to-peak. The frequency shall be varied until the package separates from the table by 4.8 mm (3/16 in) measured on any edge at or near the top of the stroke of the table.

B1.6.5 Former Test T120 (403) procedure. Production specifications for Army fuzes may specify performance of Test T120, later redesignated Test 403. This is a combined vibration and rough handling test consisting of a secured vibration test, a rough handling test identical to Test A5 and a loose cargo vibration test. Any vibration testing machine capable of meeting the conditions specified in Figure B1-17 may be used.

B1.6.5.1 Temperature Conditions. The sequential tests require two temperature conditions +71°C and -54°C (+160°F and -65°F) with one half the fuzes being subjected to each temperature. Note that there is no requirement to test fuzes at room temperature. Twelve packages are required as a minimum, six for each temperature, for packages 68 kg (150 lb) or less to fulfill the complete test procedure. Two packages as a minimum, one for each temperature, are required to fulfill the complete test procedure for packages more than 68 kg (150 lb). Each unit package shall be subjected to only one temperature. The packaged fuze shall be temperature conditioned for a minimum of 24 hours immediately prior to each test. The ambient air shall be maintained at the specified temperature level for the duration of the loose cargo and vibration tests. For all other packaged shock tests, the tests shall be conducted immediately after temperature conditioning, and as quickly as possible to maintain the specified temperature level.

B1.6.5.2 Secured vibration. Unless otherwise specified, the unit package shall be securely fastened to the vibration table. Vibratory excitation shall be applied along each of three mutually perpendicular axes of the package in turn. The vibration curves specified on Figure B1-17 shall be used. The frequency range shall be swept logarithmically from 5.5 Hz to 200 Hz to 5.5 Hz (curve AW of Figure B1-17) for 78 minutes (6 1/2 cycles at 12 minutes/cycle) and 5.5 Hz to 200 Hz (curve AX of Figure B1-17) for 6 minutes (1/2 cycles at 12 minutes/cycle). Sweep cycle may be started at 200 Hz if required by equipment limitation. Total test time for 3 axes shall be 4.2 hours.

B1.6.5.3 Rough handling for packages 68 kg (150 lb) or less. Perform Test A5, small packages (fuzes issued to ground troops), substituting the temperature requirements of B1.6.5.1

B1.6.5.4 Loose cargo vibration for unit packages 68 kg (150 lb) or less. Conduct the vibration in accordance with A5.5.2.2.

B1.6.5.5 Rough handling for packages greater than 68 kg (150 lb). Perform Test A5, large packages (bulk packages), substituting the temperature requirements of B1.6.5.1

B1.6.5.6 Loose cargo vibration for packages greater than 68 kg (150 lb). Conduct the vibration in accordance with A5.5.2.2, except that the package shall be tested 30 min in the normal shipping position (usually on skids).

B1.7 RELATED INFORMATION

B1.7.1 Vibration test parameters. The test procedures are based on measurements of vibrations experienced in the variety of commonly used transporting vehicles and platforms covering land, sea, and air transportation methods used throughout the logistical movement of the packaged fuze from manufacturer to user. Fuzes may be transported as individually packaged items or assembled to the ordnance and transported in the ammunition shipping container. The Bibliography in B1.7.10 offers additional information for unusual vehicles and for extreme operational environments. Vibration procedures devised for this test were selected from data presented in MIL-STD-810 and references B1.7.10.1, B1.7.10.2, and B1.7.10.4. Future revisions to this test may be affected as newer and more relevant data becomes available.

B1.7.2 Bare and packaged fuzes. Fuzes are almost always transported in the packaged state or assembled to the parent ammunition, which is then transported in the packaged state. However, it is sometimes necessary to determine whether a fuze design will survive transportation conditions early in the development schedule. Testing bare fuzes will provide an early look at responses to these conditions. When approved packaging is available, the fuze should be tested as a packaged item. At that time, by monitoring fuze reactions, comparisons between the bare state responses and the packaged state responses can be determined. In some instances, the package could produce a greater response in the fuze than is observed in the bare state test. Testing in the packaging is considered necessary as a qualification test to assure both the designer of the fuze and the designer of the package that the fuze is fully protected under the specific service use of combined vibration and temperature conditions. The transportation vibration test for packaged fuzes may be performed by the fuze agency or the package agency. However, since the fuze is the controlling item, the fuze agency makes the final decisions on packaging suitability and relevant test.

The vibration procedures specified for secured cargo bare fuzes and packaged fuzes are identical in frequency range and acceleration levels. Packaging normally provides a damping of higher frequencies and reduced transmissibility of acceleration-induced forces. Thus, the fuze itself should experience a lesser degree of vibration-induced damage potential when packaged. However, low frequency amplification of package vibration can occur.

B1.7.3 Packaging approved for service use. Reference B1.7.10.4 specifies the service requirements for packaging of materiel. Level A, Maximum Military Protection, is the degree of preservation or packing required for protection of materiel against the most severe conditions known or anticipated to be encountered during shipment, handling and storage. Preservation and packing designated Level A will be designed to protect materiel against direct exposure to extremes of climate, terrain, operational, and transportation environments without protection other than that provided by the pack. The conditions to be considered include, but are not limited to, (1) multiple handling during transportation and in-transit storage from point of origin to ultimate user, (2) shock, vibration and static loading during shipment, (3) loading on ship deck, transfer at sea, helicopter delivery and off-shore or over-the-beach discharge to ultimate user, (4) environmental exposure during shipment or during in-transit operations where port and warehouse facilities are limited or nonexistent, (5) extended open storage in all climatic zones, and (6) static loads imposed by stacking.

B1.7.4 Sequential transportation vibration and handling tests. This transportation vibration test for packaged fuzes, when combined with Test A5, Transportation Handling, constitutes the spectrum of vibration, handling, temperature environments encountered during transportation. When Test B1.1 and Test A5 are to be conducted sequentially on the same pack, and dummy (or inert) fuzes are used as fillers, the orientation of the available explosive-loaded fuzes (ELF) within the pack shall take into consideration both the transportation vibration and handling shock environments. Engineering judgment shall be used in selecting a compromise between uniform distribution of ELF for vibration testing and specific orientation of ELF for handling shock testing. This consideration should place a strong emphasis on testing to the shock environment, that is, placing ELF at the corners for rectangular packs or at the edges for cylindrical packs, since usually the shock transmission is the most severe at those locations.

B1.7.5 Most severe test conditions. Engineering judgment may be required to determine which locations within the pack will subject the ELF to the most severe vibration-temperature conditions. The conditions most damaging would be those combinations of amplitude and related bandwidth which affect fuze safety or operability through functional, overstress, or fatigue-related failure. However, from the standpoint of test severity, the stockpile-to-user test procedure, invoked as Unspecified Conveyance Procedure of the Secured Cargo Test, will subject the bare fuzes and packaged fuzes to the highest vibratory level that could be experienced anywhere in the logistic transportation chain (Figure B1-1).

B1.7.6 Temperature conditions. Temperature conditions are combined with the vibration conditions to simulate the service use environment. The temperature levels of -54°C (-65°F) and $+71^{\circ}\text{C}$ ($+160^{\circ}\text{F}$) are the nominal extremes encountered and are thus used to evaluate the suitability of fuzes to withstand the extremes. The ambient temperature of $+23^{\circ}\text{C}$ ($+73^{\circ}\text{F}$) is considered to be the most probable level of occurrence for the mid-range.

B1.7.7 Fuze resonance conditions. If fuze resonance is suspected within the frequency range of the vibration schedule, then suitable instrumentation to obtain amplification data may be devised and used as part of the test. This is especially important if the fuze experiences degradation of safety or reliability as a result of the test, and further diagnostic information is needed. Additionally, instrumentation should be used to provide data for use when correlation between bare and packaged fuze testing is required.

B1.7.8 Mechanical vibration effects. If the safety condition of the fuzes after test is in doubt, inspection by radiography is recommended prior to disassembly and inspection. If the safety condition is in doubt, only specially trained explosive-ordnance handling personnel should be authorized to handle and/or dispose of the fuze. In general, the results of vibration tests are manifest in varying degrees of abrasion, loosening of components, and so forth. Distinction between reasonable wear and borderline or serious damage, significant in terms of safety or operability, shall be made on the basis of engineering judgment, including studies under dynamic operating conditions where practical.

B1.7.9 Rationale for revision. This revision is made necessary by the preponderance of data indicating that the various land-air-sea vehicles and platforms used to transport fuzes from manufacturing plant to the user in the field (Figure B1-1), with few exceptions, transmit random vibrations to the fuzes. Sinusoidal vibration, which previously constituted the standard test, has been designated an alternate test for older fuzes and is now described in B1.6. Extensive data records, such as at TECOM/CSTA (ITOP 1-2-601, reports, etc.) and other DoD test standards, such as MIL-STD-810, provide ample justification for the changing trend wherein sinusoidal vibration is replaced by random vibration. Because random vibrations provide a greater degree of

MIL-STD-331C
w/CHANGE 1
APPENDIX B

test realism and are capable of producing damage mechanisms not induced by sinusoidal vibration, it is necessary to revise this test. The few instances where sinusoidal vibration was retained correspond to situations that include propeller vibrations of combat ships (thus retaining consistency with MIL-STD-167) and main-shaft harmonics produced by utility and combat helicopters.

B1.7.10 Bibliography

B1.7.10.1 ITOP 1-2-601, *Laboratory Vibration Schedules*, U.S. Army Test and Evaluation Command, Combat-Systems Test Activity, Aberdeen Proving Ground, MD 21005-5059.

B1.7.10.2 AR 70-38, *Research, Development, Test and Evaluation of Material for Extreme Climatic Conditions*.

B1.7.10.3 AR 700-15, NAVSUPINST 4030.28A, AFR 716-6, MCO 4030.33A, *Packaging of Material*.

B1.7.10.4 *Vibration Criteria for C-130 (C-130A through C-130J)*, J. A. Bair, WPAFB, Structures Division Dir of Flight Systems Engr., FAX communication, 1 August 1996.

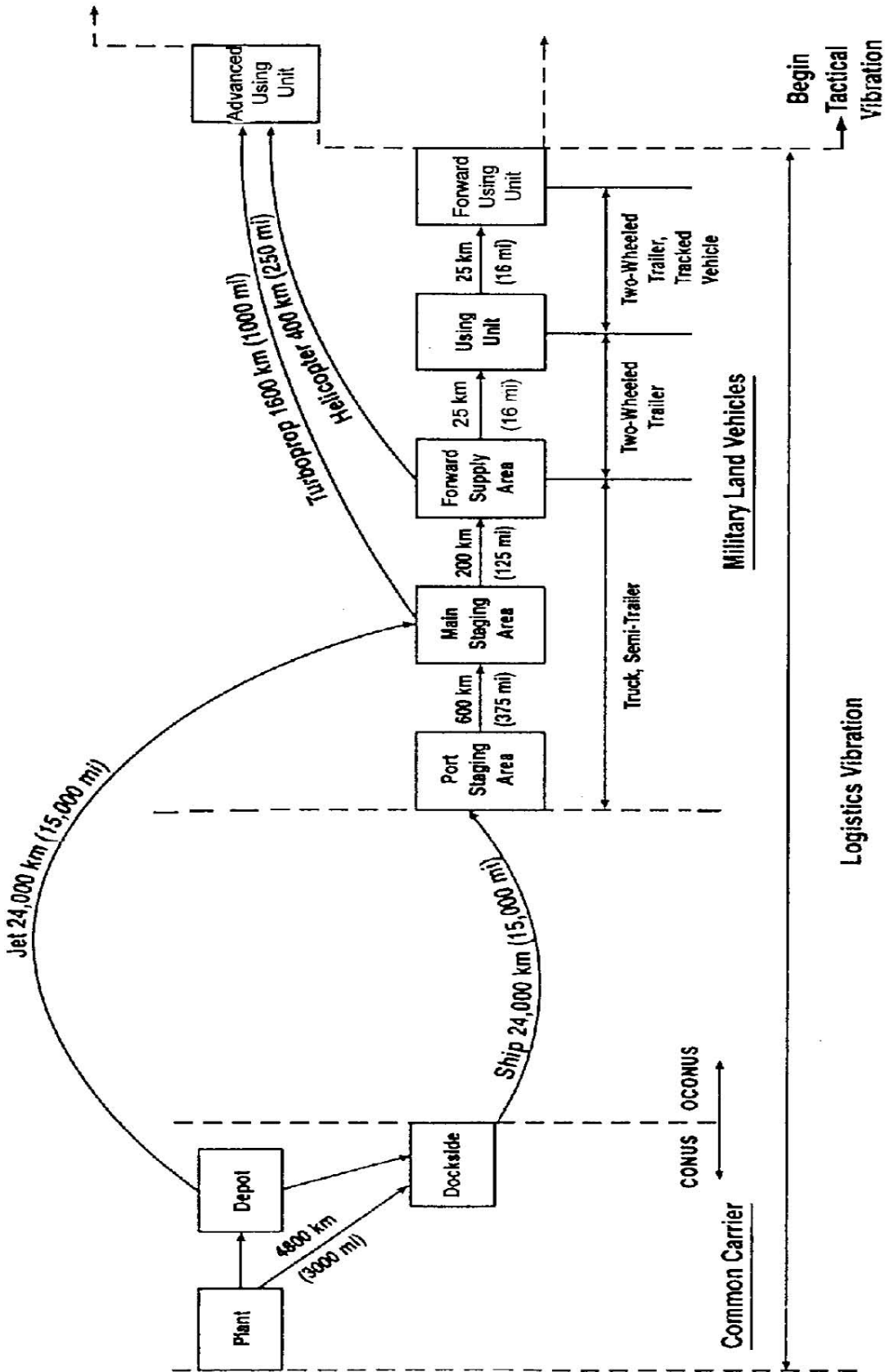

Note: Not all conveyances shown are necessarily used in any one-time shipment

FIGURE B1-1. Typical one-time, one way transportation scenario for fuzes.

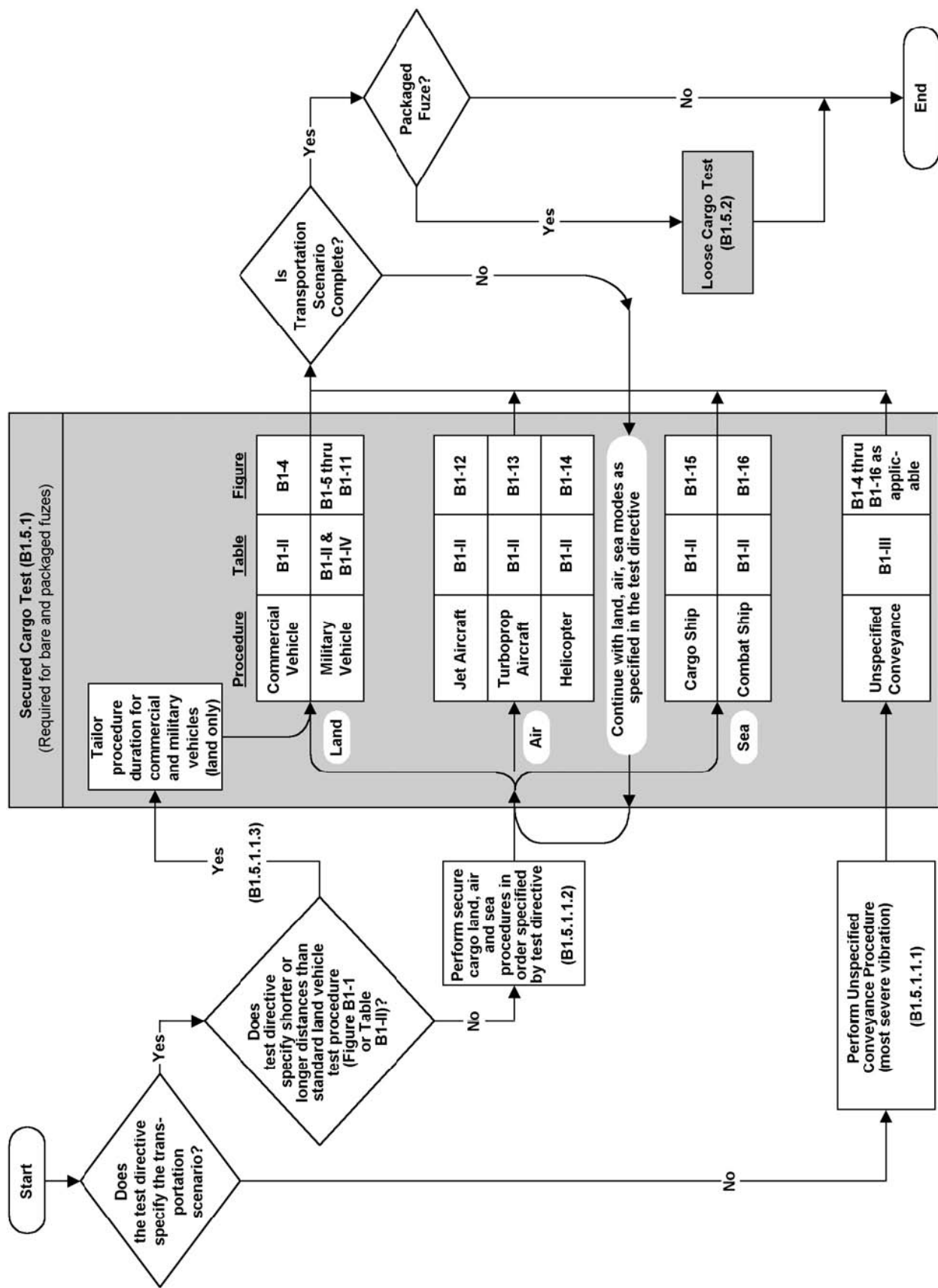

FIGURE B1-2. Test procedure selection guide

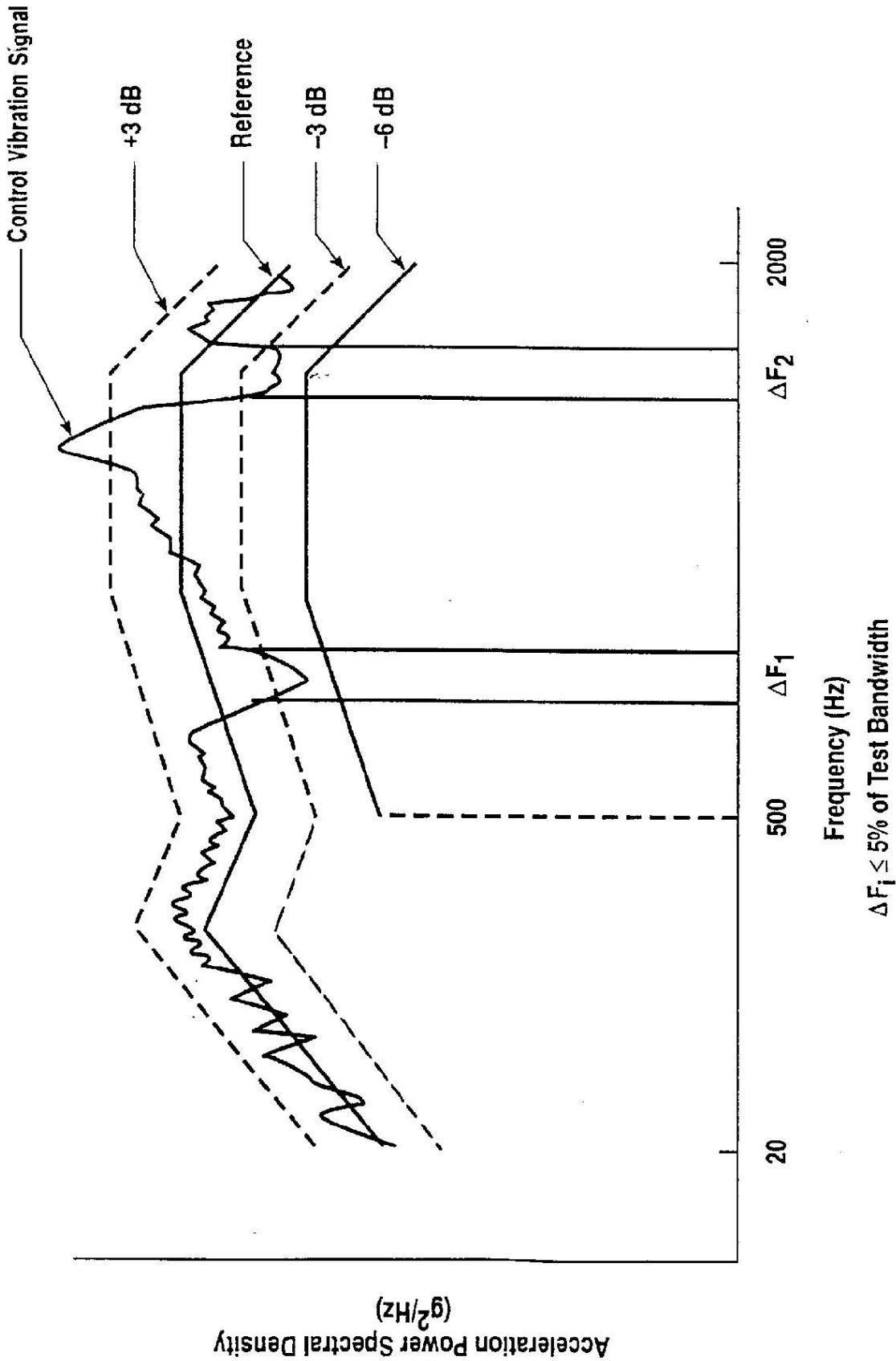

FIGURE B1-3. Example of acceptable random vibration power spectral density.

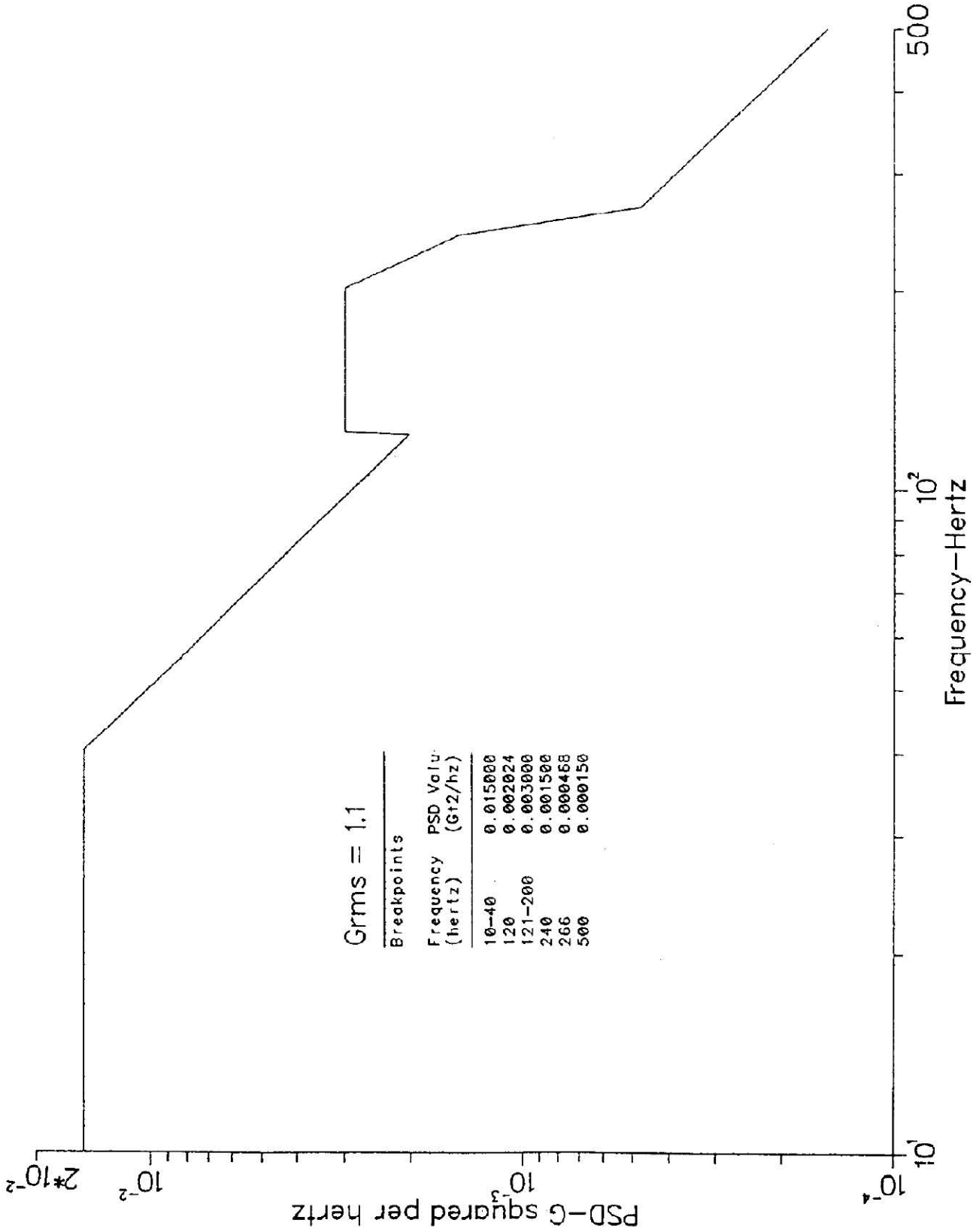

FIGURE B1-4. Vibration test spectrum for commercial vehicles (composite).

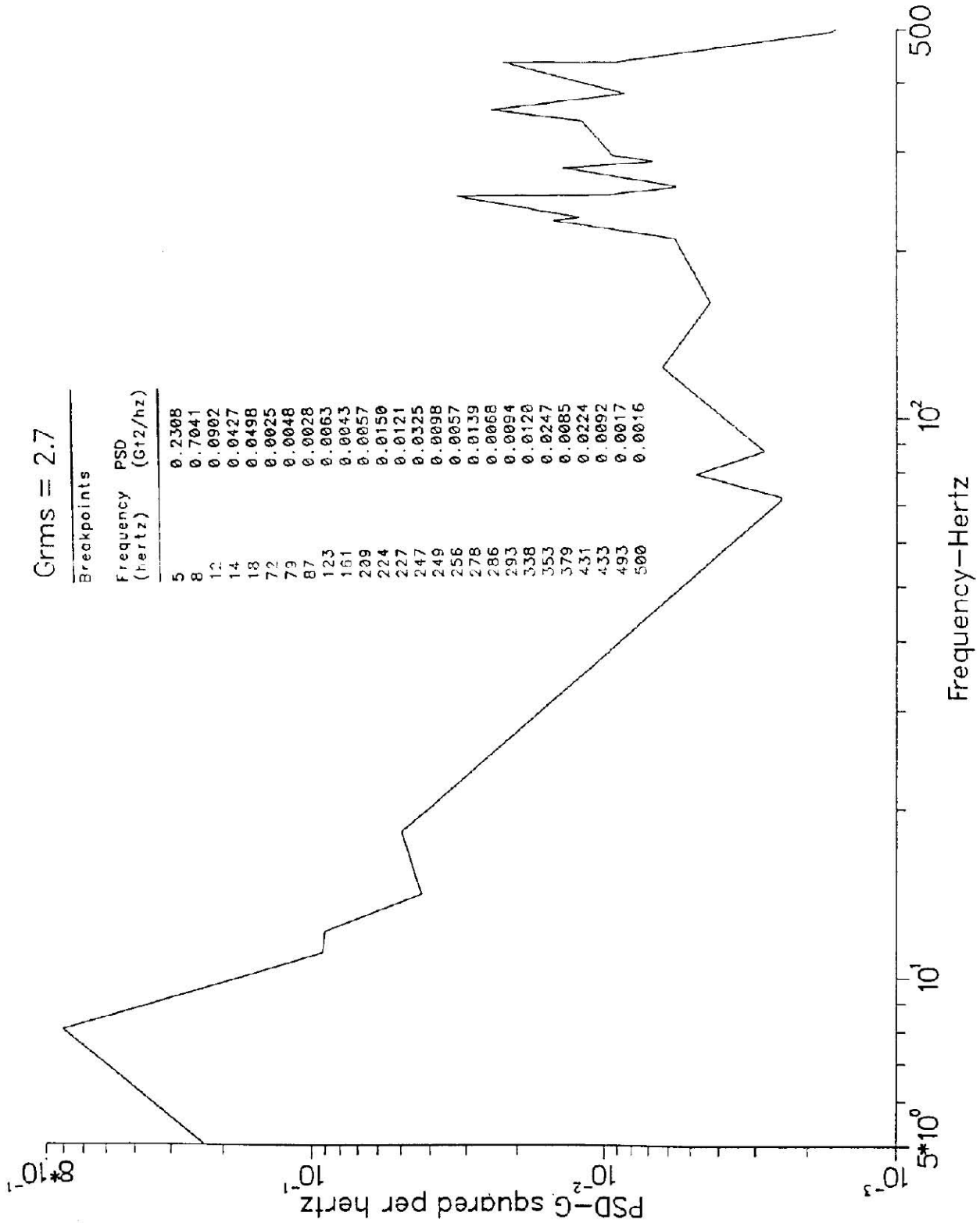

FIGURE B1-5. Vibration test spectrum for military wheeled vehicle (composite).

Grms = 3.9

Breakpoints

Frequency (hertz)	PSD (Gr ² /hz)
5	0.2252
8	0.5508
10	0.0437
13	0.0253
15	0.0735
18	0.0208
20	0.0183
23	0.0358
27	0.0123
30	0.0286
34	0.0133
36	0.0416
41	0.0103
45	0.0241
51	0.0114
95	0.0266
111	0.0166
136	0.0683
146	0.0450
151	0.0293
155	0.0332
158	0.0549
162	0.0376
165	0.0401
185	0.0603
262	0.0633
330	0.0083
360	0.0253
500	0.0017

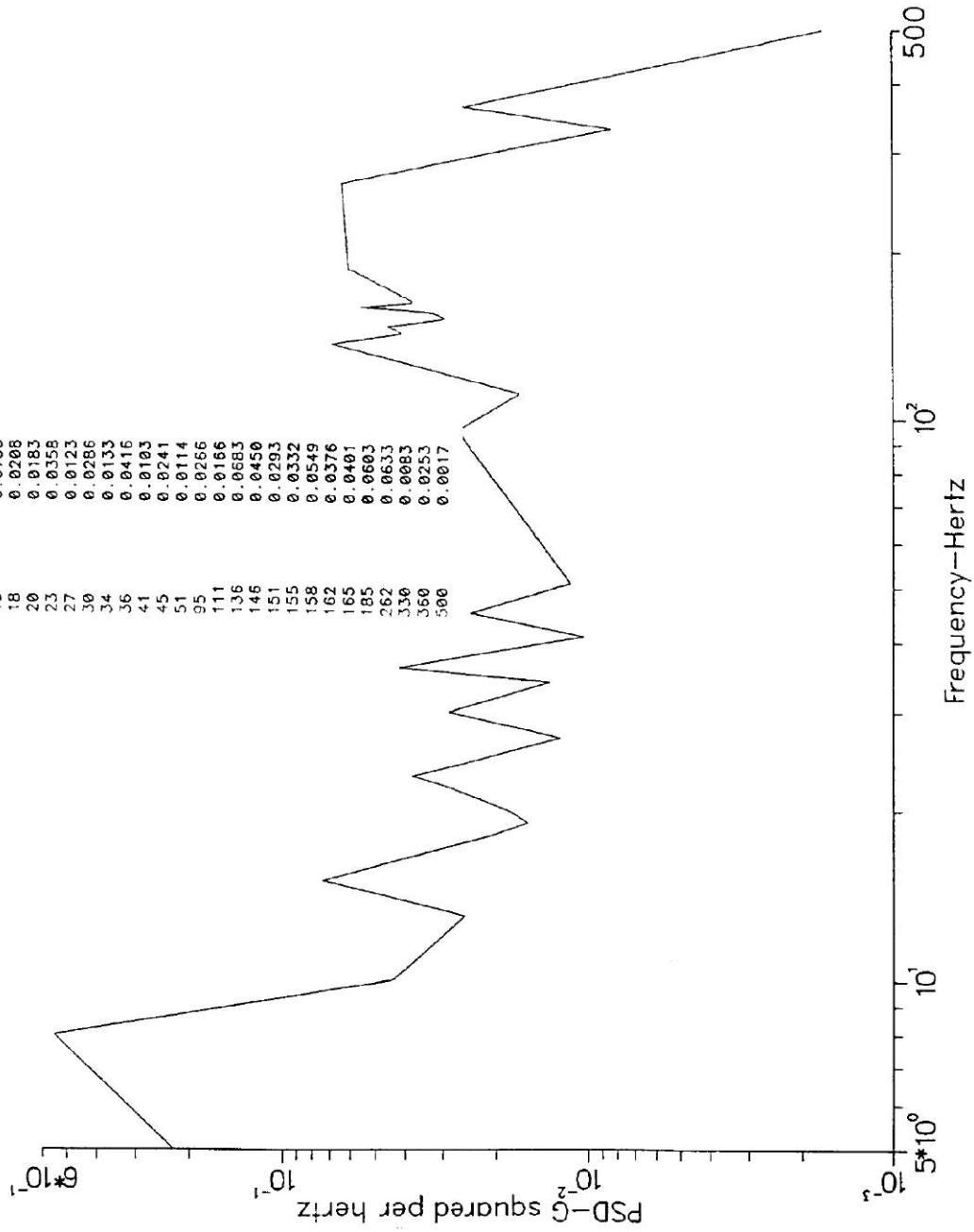

FIGURE B1-6. Vibration test spectrum for military two-wheeled trailer (composite).

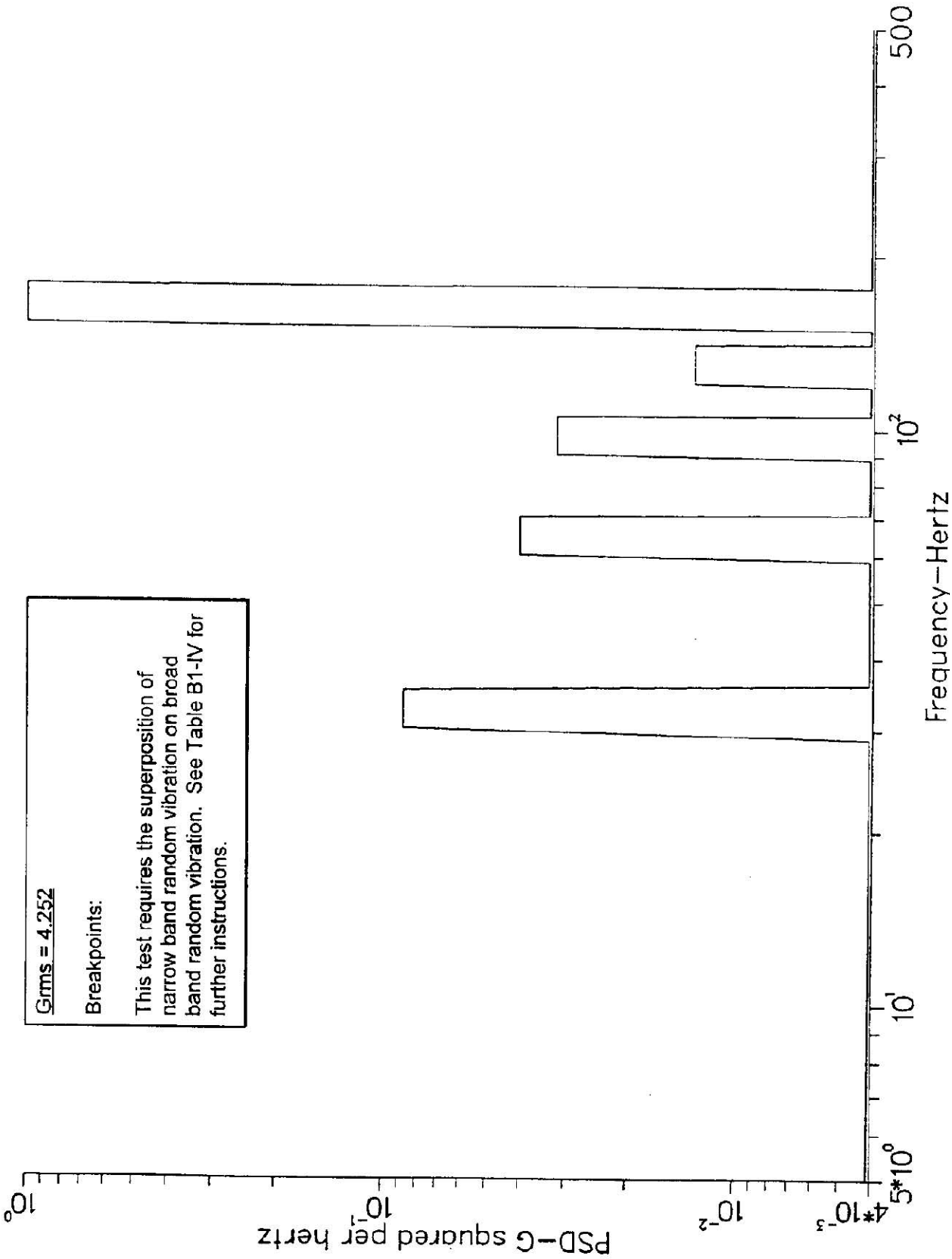

FIGURE B1-7. Vibration test spectrum for military tracked vehicle - phase 1 (composite).

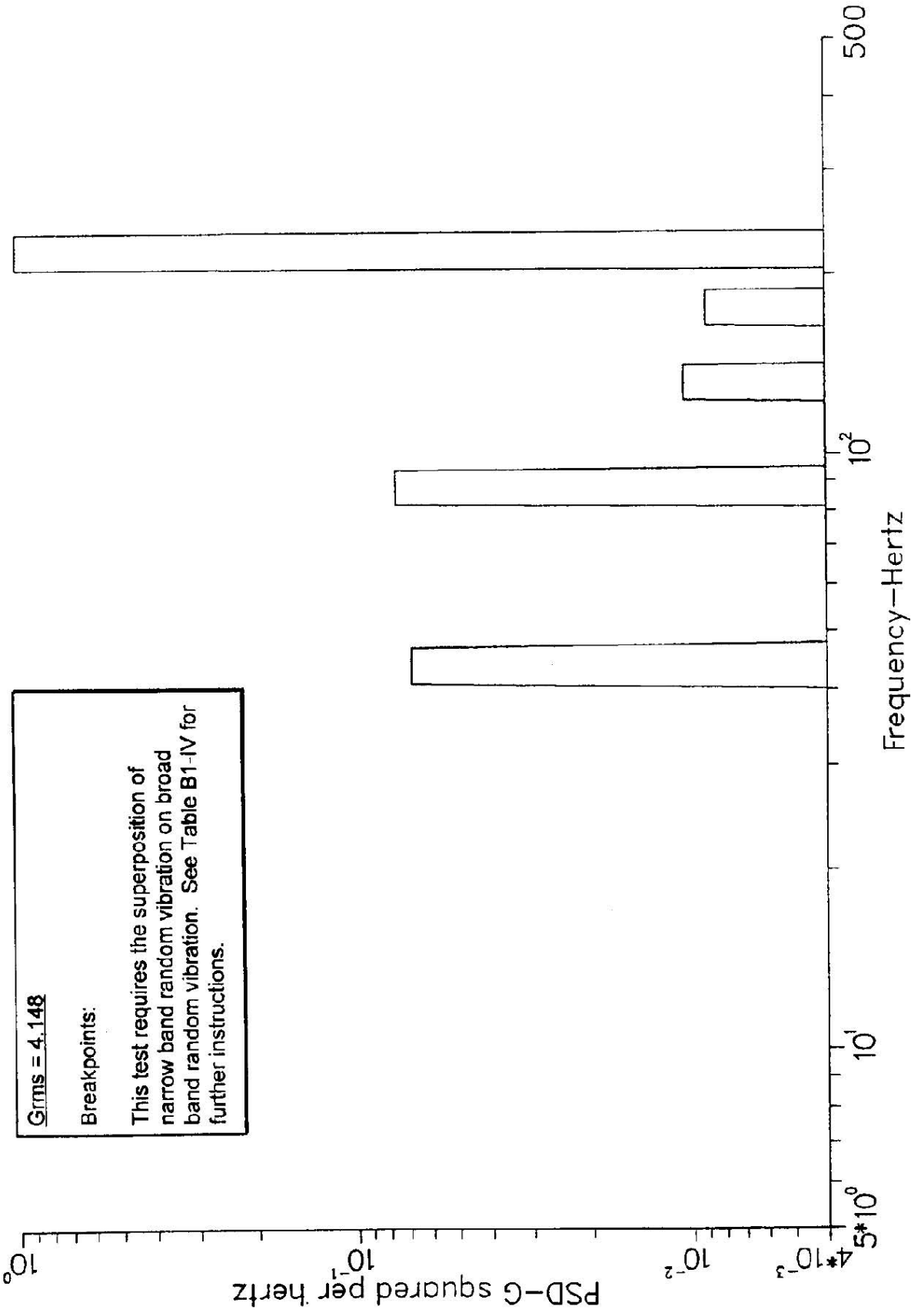

FIGURE B1-8. Vibration test spectrum for military tracked vehicle - phase 2 (composite).

Grms = 4.148
Breakpoints:
This test requires the superposition of narrow band random vibration on broad band random vibration. See Table B1-IV for further instructions.

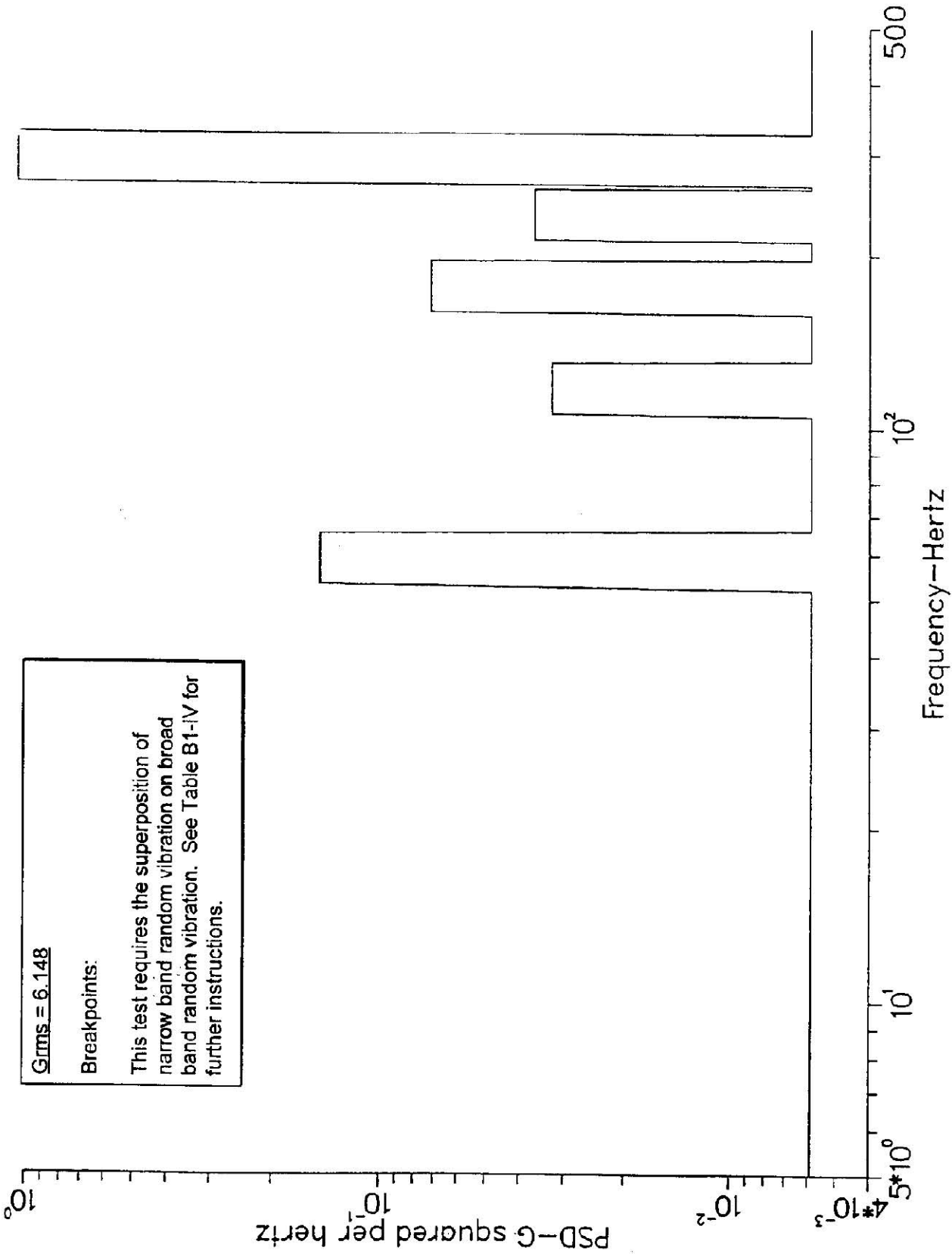

FIGURE B1-9. Vibration test spectrum for military tracked vehicle - phase 3 (composite).

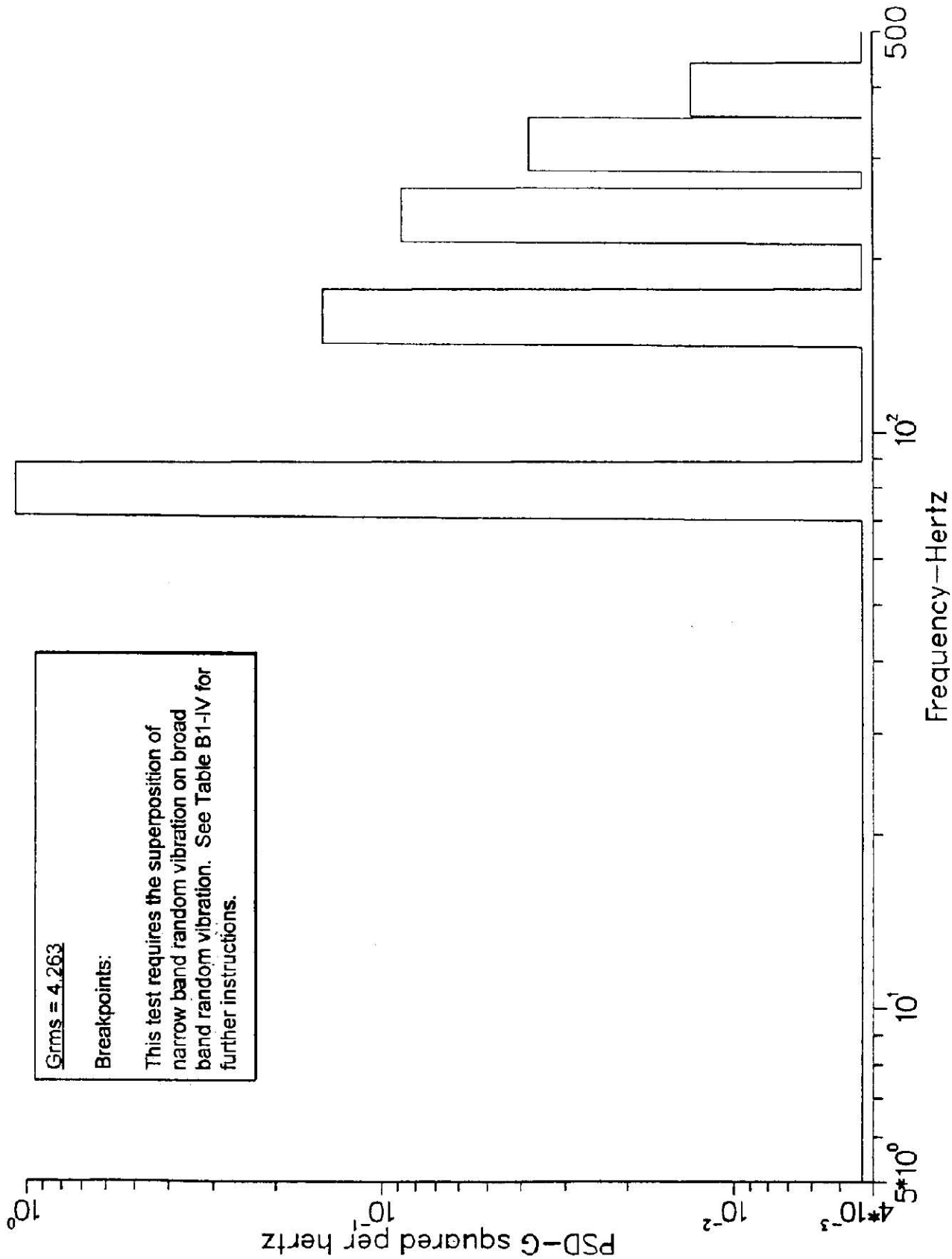

FIGURE B1-10. Vibration test spectrum for military tracked vehicle - phase 4 (composite).

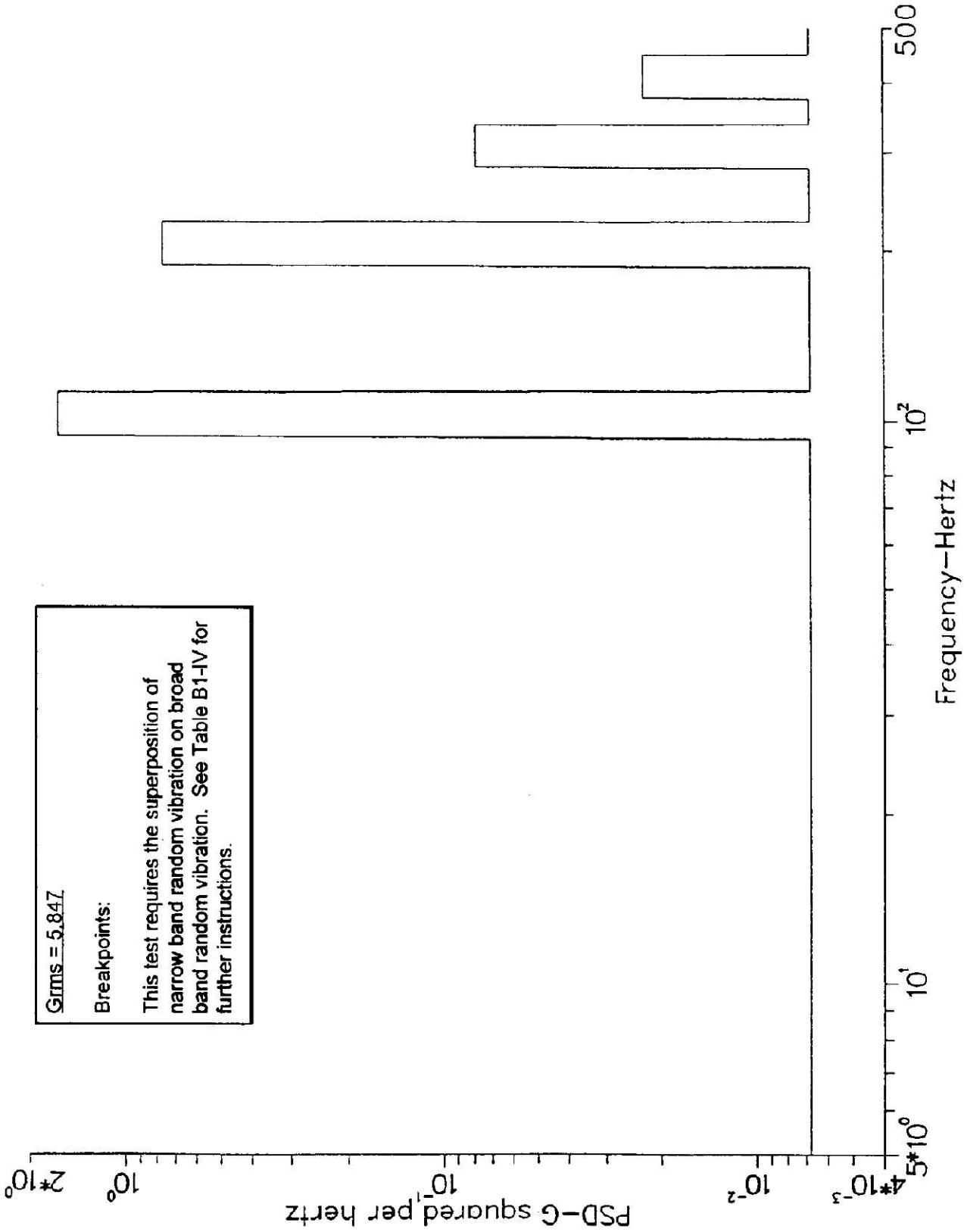

FIGURE B1-11. Vibration test spectrum for military tracked vehicle - phase 5 (composite).

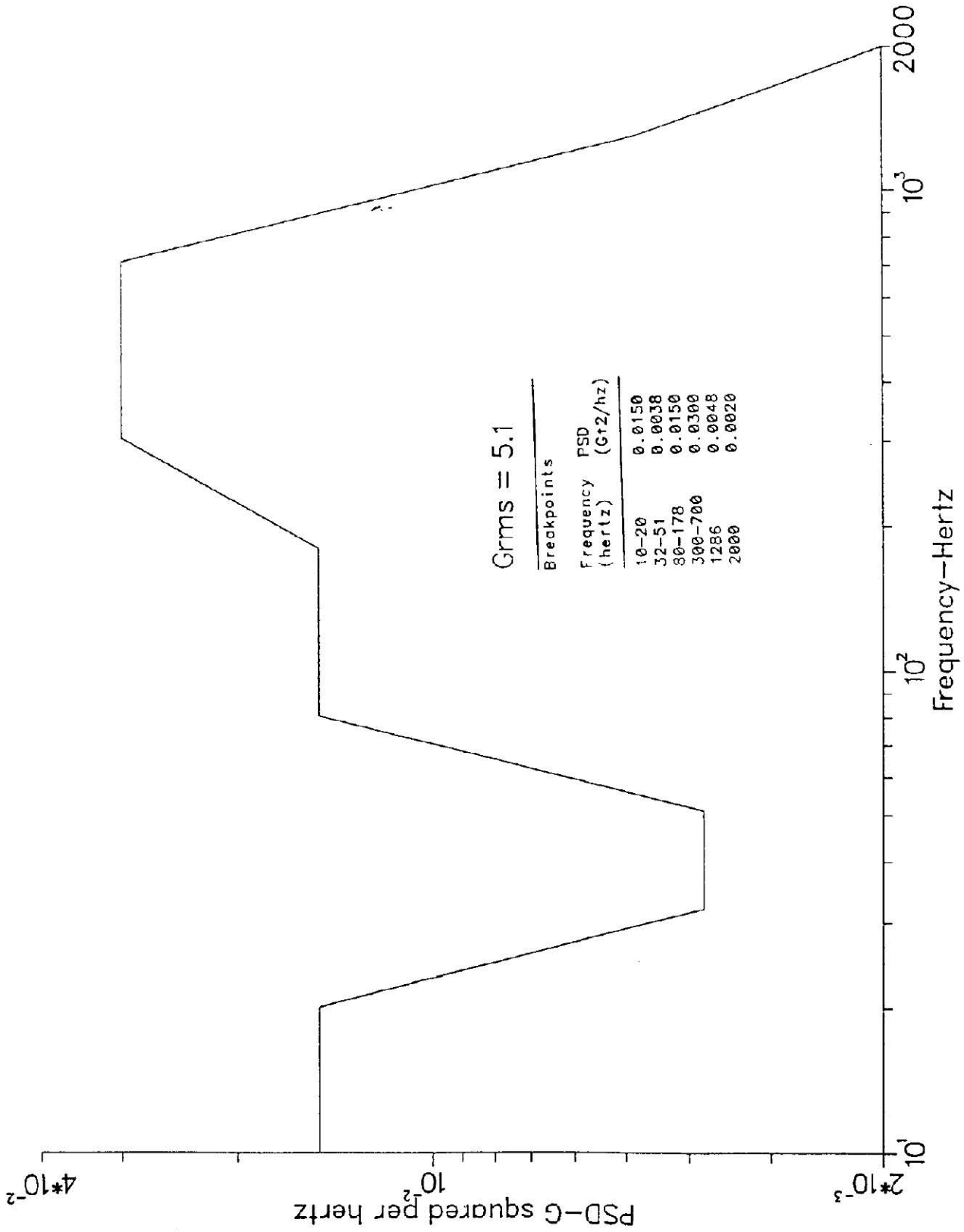

FIGURE B1-12. Vibration test spectrum for jet aircraft (composite).

MIL-STD-331C
w/CHANGE 1
APPENDIX B

Criteria Curve Break Points

Freq. (Hz)	Ampl. (g ² /Hz)	Freq. (Hz)	Ampl. (g ² /Hz)	Freq. (Hz)	Ampl. (g ² /Hz)	Freq. (Hz)	Ampl. (g ² /Hz)
15.0	0.01	104.5	0.30	173.3	0.01	290.7	0.01
52.3	0.01	104.5	0.08	193.8	0.01	290.7	0.03
52.3	0.30	115.5	0.08	193.8	0.03	321.3	0.03
57.8	0.30	115.5	0.01	214.2	0.03	321.3	0.01
57.8	0.01	129.2	0.01	214.2	0.02	387.6	0.01
64.6	0.01	129.2	0.08	231.0	0.02	387.6	0.02
64.6	0.30	142.8	0.08	231.0	0.01	428.4	0.02
71.4	0.30	142.8	0.01	258.4	0.01	428.4	0.01
71.4	0.01	156.8	0.01	258.4	0.02	2000	0.01
96.9	0.01	156.8	0.03	285.6	0.02		
96.9	0.30	173.3	0.03	285.6	0.01	5.44 g rms	

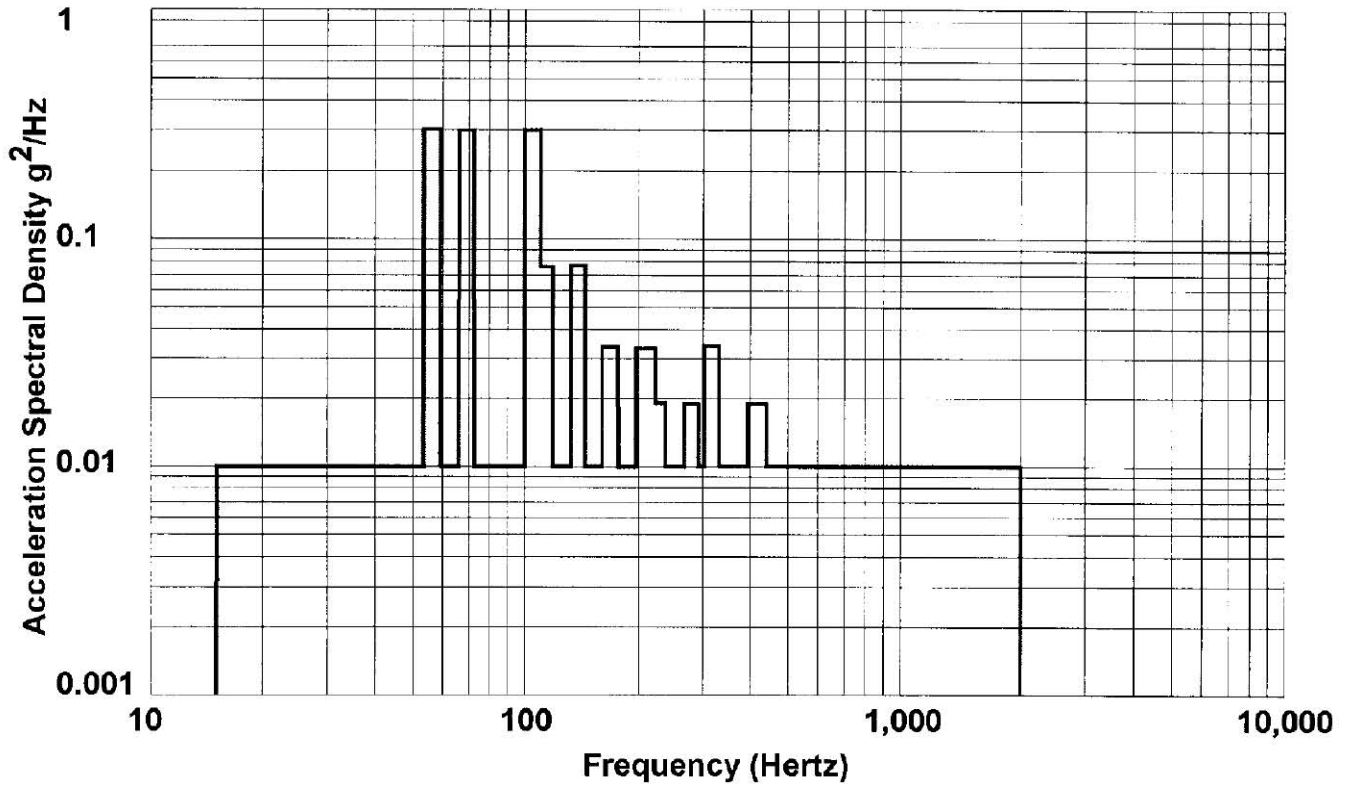

FIGURE B1-13. Vibration Test Spectrum for Turboprop Aircraft (composite)

Main Rotor First Four Harmonics (sinusoidal components)

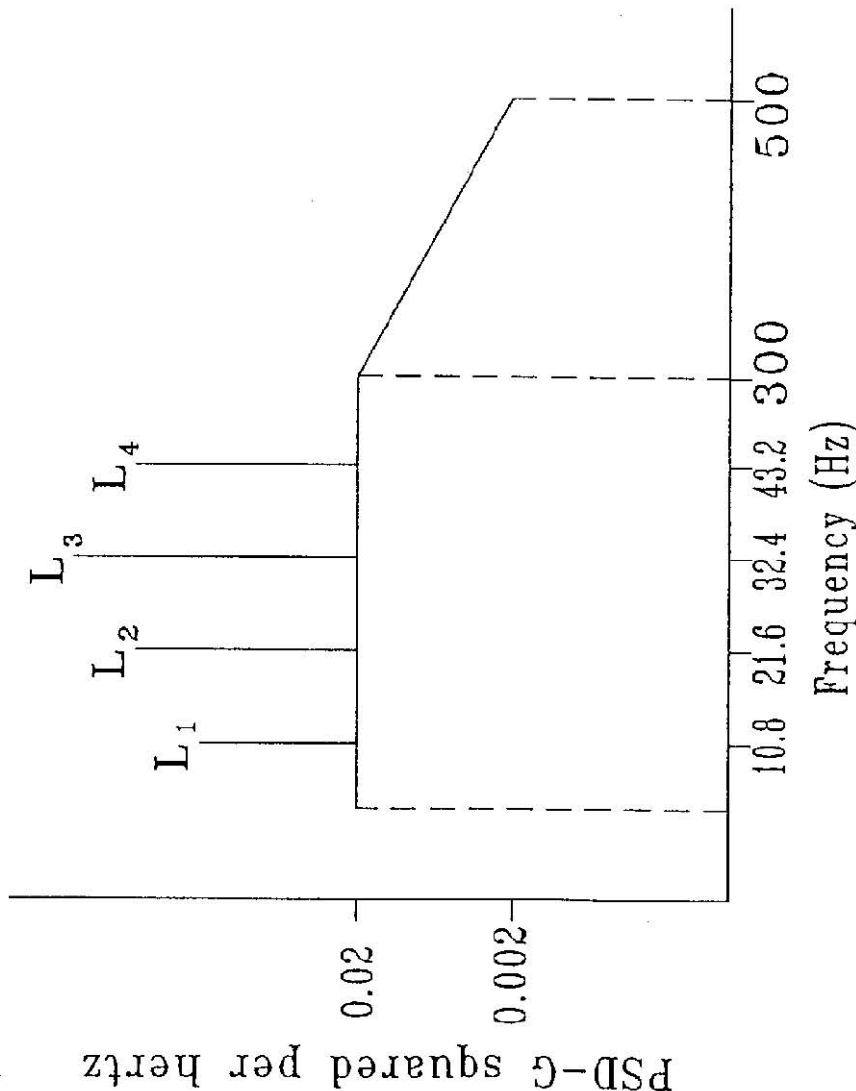

FIGURE B1-14. Vibration test spectrum for helicopters, utility and general purpose.

Acceleration Level (pk. g)				G rms	
L ₁	L ₂	L ₃	L ₄	Random Spectrum	Random Spectrum Plus Harmonics
1.4	2.2	2.5	2.2		
Frequency (Hz)					
10.8	21.6	32.4	43.2	2.8	4.5

Note: Sinusoidal components maintained at indicated frequencies for the test duration.

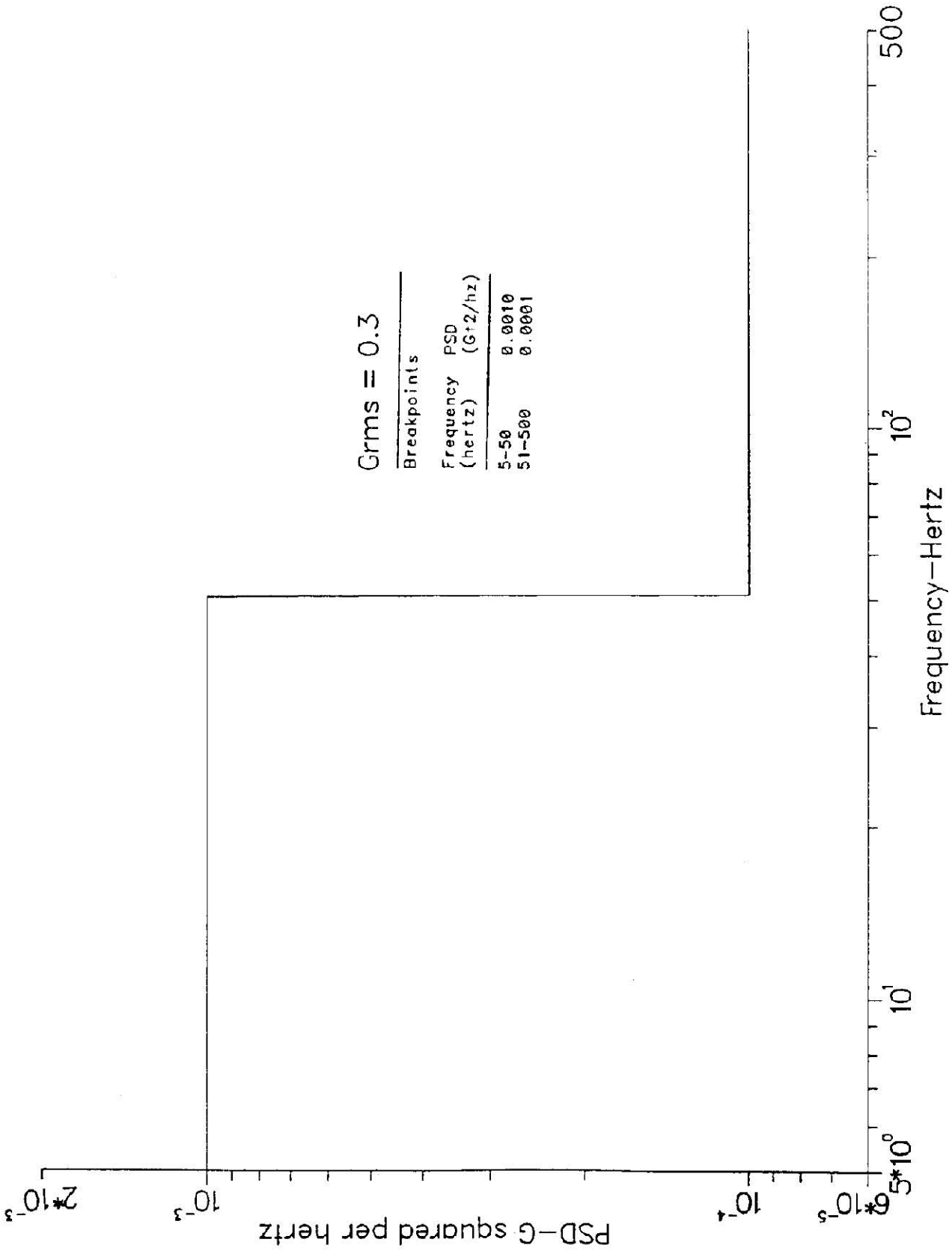

FIGURE B1-15.

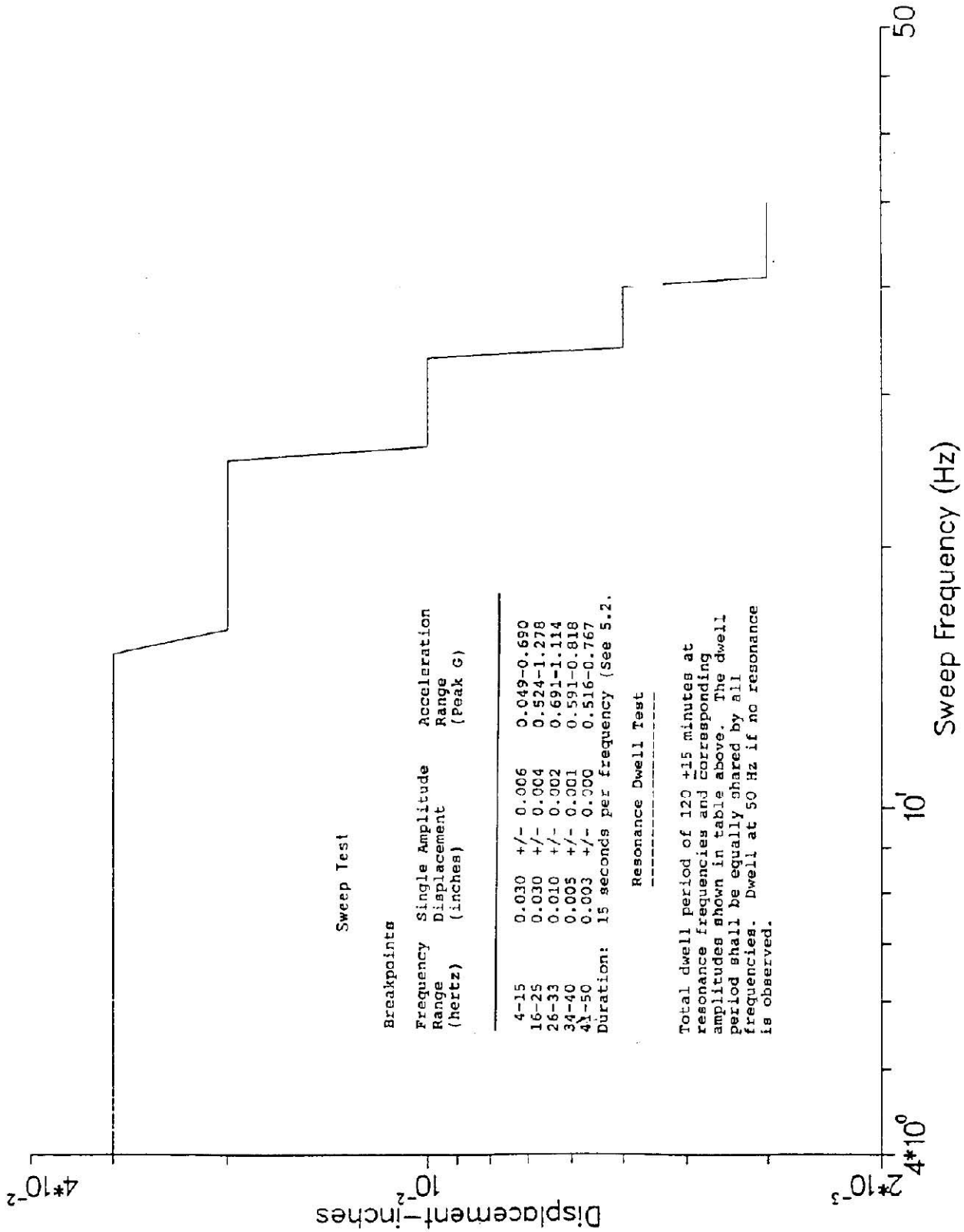

FIGURE B1-16. Vibration test spectrum for combat ships (composite).

MIL-STD-331C
w/CHANGE 1
APPENDIX B

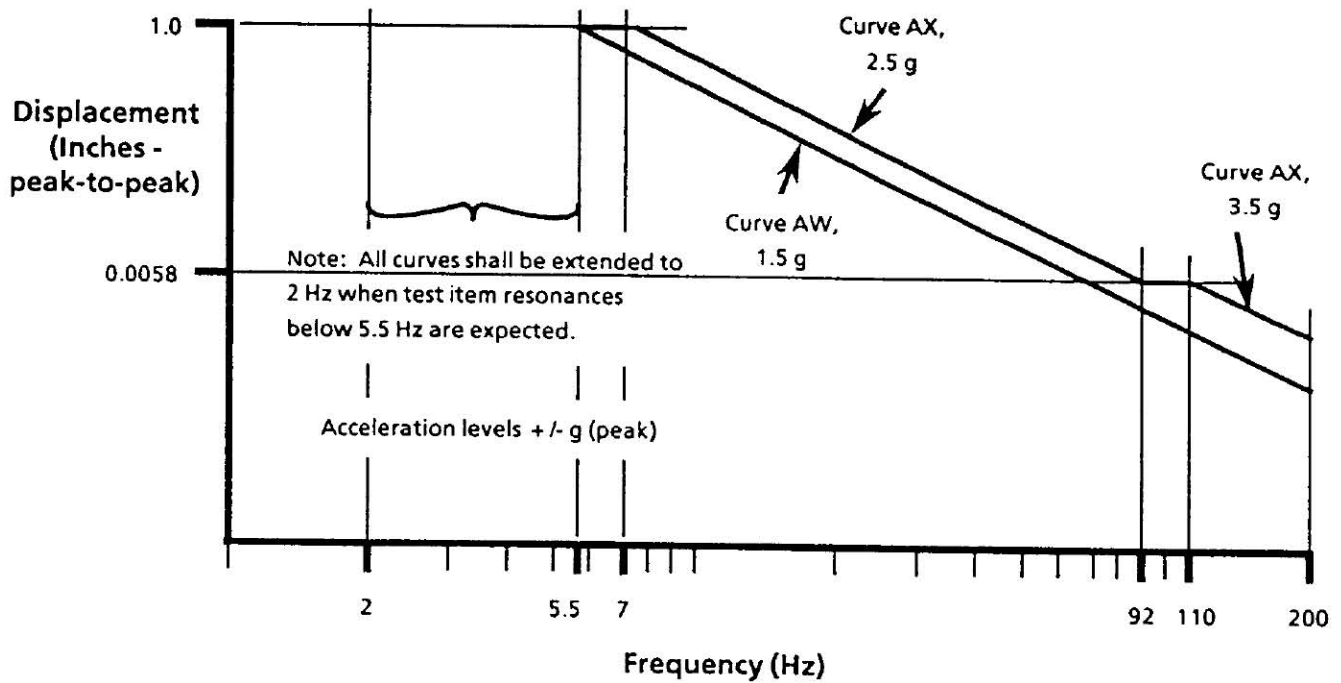

FIGURE B1-17. Vibration Test Curve for Equipment Transported as Secured Cargo (Alternate test for older Army fuzes. See Section B1.6.5)

MIL-STD-331C
w/CHANGE 1
APPENDIX B

TABLE B1-I. Test Procedures For Fuze Secured Cargo Vibration Test

This table shows the applicable test procedure to be performed for each type of ordnance and transportation mode. This is for a one-time, one-way, typical land-air-sea transportation scenario with the fuze transported as secured cargo. A “Yes” indicates it is highly likely that this transportation mode will be used to transport the fuzes from the stockpile to the user. A “No” indicates this transportation mode is not likely.

Ordnance Type	Transportation Mode							
	Land		Air			Sea		Combi ned Land- Air- Sea
	Comm ercial Vehicle Proced ure	Military Vehicle Procedur es	Jet Aircraft Procedu re	Turbopr op Aircraft Procedu re	Helicopt er Procedu re	Cargo Ship Procedu re	Combat Ship Procedu re	Unspe cified Conve yance Proced ure
Artillery	Yes	Yes	Yes	Yes	Yes	Yes	Yes	Yes
Mortar	Yes	Yes	Yes	Yes	Yes	Yes	Yes	Yes
Tank	Yes	Yes	Yes	Yes	Yes	Yes	Yes	Yes
Self- propelled Howitzer	Yes	Yes	Yes	Yes	Yes	Yes	Yes	Yes
Rocket	Yes	Yes	Yes	Yes	Yes	Yes	Yes	Yes
Missile	Yes	Yes	Yes	Yes	Yes	Yes	Yes	Yes
Land Mine	Yes	Yes	Yes	Yes	Yes	Yes	Yes	Yes
Small Arms	Yes	Yes	Yes	Yes	Yes	Yes	Yes	Yes
Hand- emplaced Ordnance (See Note)	Yes	Yes	Yes	Yes	Yes	Yes	Yes	Yes
Bomb	Yes	No		No	No	Yes	Yes	Yes
Torpedo	Yes	No	No	No	No	Yes	Yes	Yes
Depth Charge	Yes	No	No	No	No	Yes	Yes	Yes
Sea Mine	Yes	No	No	No	Yes	Yes	Yes	Yes

MIL-STD-331C
w/CHANGE 1
APPENDIX B

Test Requirement	Table B1-II	Table B1-II	Table B1-II	Table B1-II	Table B1-II	Table B1-II	Table B1-II	Table B1-III
------------------	-------------	-------------	-------------	-------------	-------------	-------------	-------------	--------------

Note: This category includes hand-thrown munitions, such as hand grenades and fuzed demolition devices.

TABLE B1-II. Test Requirements For Specified Transportation Scenario (Note 4)

This table contains test requirements where the transportation modes and one-way distances are specified by the test directive. Requirements for unspecified scenarios are listed in Table B1-III.

Test Procedure	Transport Distance (mi (km))	Test Requirements		
		Test Profile Figure	Test Duration Per Axis (minutes)	Test Level (Grms) ^{Note 2}
Commercial Vehicle Procedure	3000 (4800)	B1-4	180	1.1
Military Vehicle Procedures				
Military Wheeled Vehicle Procedure	500 (800)	B1-5	40	2.7
Military Two-wheeled Vehicle Procedure	32 (50)	B1-6	32	3.9
Military Tracked Vehicle Procedure ^{Note 1}	16 (25)	Five figures as follows:	60; subdivided as follows:	As follows for each phase:
	Phase 1	B1-7	12	4.252
	Phase 2	B1-8	12	4.148
	Phase 3	B1-9	12	6.148
	Phase 4	B1-10	12	4.263
	Phase 5	B1-11	12	5.847
Jet Aircraft Procedure	15,000 (24,000)	B1-12	1	5.1
Turboprop Aircraft Procedure	1,000 (1,600)	B1-13	120	5.44
Helicopter Procedure	250 (400)	B1-14	60	4.5/2.8 ^{Note 3}
Cargo Ship Procedure	15,000 (24,000)	B1-15	120	0.3
Combat Ship Procedure	15,000 (24,000)	B1-16	235 (sine sweep) 120 (sine) sweep	1.3g peak at 25 Hz

Notes:

1. Phases correspond to a total distance of 25 km at 5 different vehicle speeds. This test requires

MIL-STD-331C
w/CHANGE 1
APPENDIX B

the superposition of narrow band random vibration on broadband random vibration. Refer to Table B1-IV for further instructions.

2. Grms = root mean squared acceleration for broadband random vibration, unless otherwise indicated.
3. Grms = 2.8 (broadband random); Grms = 4.5 (broadband random plus harmonic components).
4. All test profiles listed in this table call for random vibration input to the fuze, except for B1-16, which calls for sinusoidal input.

TABLE B1-III. Test Requirements For Unspecified Transportation Scenario

This table shall be used when the transportation modes and one-way distances are not specified by the test directive

Ordnance Type	Refer to Table B1-II for Test Requirement of Procedures Cited Below
Artillery	Military Wheeled Vehicle, Military Two-wheeled Vehicle, Military Tracked Vehicle, Turboprop Aircraft and Helicopter
Mortar	
Tank	
Self-propelled Howitzer	
Rocket	
Missile	
Land Mine	
Small Arms	
Hand-emplaced Ordnance	Commercial Vehicle, Jet Aircraft and Combat Ship
Bomb	Commercial Vehicle and Combat ship
Torpedo	
Depth Charge	
Sea Mine	Commercial Vehicle, Helicopter, Cargo Ship and Combat Ship

MIL-STD-331C
w/CHANGE 1
APPENDIX B

TABLE B1-IV. Narrow-band Random-on-Random Vibration Breakpoints for Military Tracked Vehicle (Composite)

Use this table in conjunction with Table B1-II and Figures B1.7 through B1.11.

Test Phase	Grms ² (g /Hz)	Floor Level ² (g /Hz)	No. Sweeps	Narrowband 1			Narrowband 2			Narrowband 3			Narrowband 4			Narrowband 5		
				Band - width (Hz)	Ampl ² (g /Hz)	Sweep Band - width (Hz)	Band - width (Hz)	Ampl ² (g /Hz)	Sweep Band - width (Hz)	Band - width (Hz)	Ampl ² (g /Hz)	Sweep Band - width (Hz)	Band - width (Hz)	Ampl ² (g /Hz)	Sweep Band - width (Hz)	Band - width (Hz)	Ampl ² (g /Hz)	Sweep Band - width (Hz)
1	4.252	0.004 ₁	2	30-35	0.0876	3	60-70	0.0405	6	90-105	0.0319	9	120-140	0.0131	12	150-175	1.0173	15
2	4.148	0.002 ₄	2	41-47	0.0686	3	82-94	0.0759	6	123-141	0.0105	9	164-188	0.0090	12	205-235	1.0173	15
3	6.148	0.005 ₉	1	53-65	0.1480	6	106-130	0.0325	12	159-195	0.0717	18	212-260	0.0363	24	265-325	1.0655	30
4	4.263	0.004 ₃	1	71-88	1.0722	9	142-176	0.1480	18	213-264	0.0873	27	284-352	0.0378	36	355-440	0.0132	45
5	5.847	0.006 ₈	1	94-112	1.6288	9	188-224	0.7682	18	282-336	0.0787	27	376-448	0.228	36	-	-	-

Notes:

1. Floor Level -designates the broadband PSD amplitude for the test.

MIL-STD-331C
w/CHANGE 1
APPENDIX B

2. Bandwidth - designates the narrow bandwidth for which the (PSD) amplitude exceeds the floor level amplitude.
3. Sweep Bandwidth - designates the swept bandwidth within the corresponding narrow bandwidth. This quantity is always smaller than the corresponding bandwidth.
4. No. Sweeps indicates the number of cycles the sweep bandwidth is swept across the corresponding narrow band during the test. A cycle is completed when the frequency is swept from its lowest value to the highest value and back to the lowest value. This process is maintained for the entire test duration.
5. Narrowband Random-on-Random - The five narrowbands are superimposed on the floor level for the entire test duration. Thus the Grms represents the total contributed from the coexisting narrowband and broadband (floor level) random vibrations.
6. Certain digital control systems by nature of their design, might produce a total number of sweeps fractionally different from the specified value. This is an acceptable deviation as long as the total number of sweep cycles is within ± 10 percent of the specified value.

TEST B2

**Requirements for transportation vibration tests of packaged fuzes
have been combined with those for bare fuzes.
Refer to Test B1.1.**

TEST B3

TACTICAL VIBRATION

B3.1 PURPOSE

This is a laboratory safety and reliability test simulating tactical conditions. The fuze is preconditioned to specified temperatures and vibrated on a schedule of controlled frequencies and amplitudes.

B3.2. DESCRIPTION

B3.2.1 General description. Bare fuzes are subjected to combined vibration-temperature conditions which are defined by the service application of the fuze, that is, the type of munition, weapon or tactical launch vehicle. Four different test procedures are provided to cover most applications. Exclusions are described in more detail in B3.7. Each procedure is devised to cover the vibration-temperature environment of the tactical pre-launch period (fuze is assembled to parent weapon or vehicle as a “ready to use” store), and the launch and post-launch period (parent weapon or vehicle during launch or in free flight) up to the fuze initiation at the desired target point. The test fuze will be in a non-operating or operating state, as required, by each application and procedure.

B3.2.1.1 Air-launched munitions. This procedure (B3.5.3) is for fuzes designed for use in munitions air-launched from an external-carry position. Helicopter-launched items are excluded. See B3.7.3.

B3.2.1.2 Ground-launched munitions. This procedure (B3.5.4) is for fuzes designed for use in munitions launched from fixed or moving ground launchers. Artillery fuzes are excluded. See B3.7.4.

B3.2.1.3 Ship-launched munitions. This procedure (B3.5.5) is for fuzes designed for use in munitions launched from ships. See B3.7.5.

B3.2.1.4 Underwater-launched munitions. This procedure (B3.5.6) is for fuzes designed for use in munitions launched from underwater vehicles or carriers.

B3.2.2 Fuze configuration. The fuzes for this test shall be completely assembled, including all explosive elements which are a part of the fuze design. Inert lead and booster elements may be substituted when the use of live elements present an excessive hazard. The inert elements shall have an equivalent weight and configuration. When inert elements are used, the live elements and their interface with the fuze shall be separately qualified to the tactical vibration environment.

B3.2.3 Applicable publications. All standards, specifications, drawings, procedures and manuals which form a part of this test are listed in Section 2 of the introduction to this standard. Special attention is directed to MIL-STD-167, MIL-HDBK-310, MIL-STD-810, and MIL-T-18404.

B3.2.4 Test documentation. Test plans, performance records, equipment, conditions, results and analysis shall be documented in accordance with 4.8 of the general requirements to this standard.

B3.3. CRITERIA FOR PASSING TEST

B3.3.1 Fuze condition. At the completion of this test, the fuze shall be safe for transportation, storage, handling and use, as well as operable in accordance with 4.6.2.1 and

4.6.2.2a of the general requirements to this standard.

B3.3.2 Decision basis. Breakdown, inspection, other appropriate tests and engineering judgment shall form the bases of the decision that fuzes have passed or failed the test.

B3.4. EQUIPMENT

B3.4.1 Vibration equipment. The equipment shall be capable of covering the frequency ranges and acceleration levels specified in B3.5. Frequency sweeping shall be at a logarithmic rate over the range, or at a linear rate over the range when the range is divided into logarithmic increments.

B3.4.2 Temperature equipment. The equipment shall be capable of establishing and maintaining the temperature levels specified for the time durations required. Tolerances are as specified in each procedure, or as specified in 4.5.2.

B3.4.3 Instrumentation. The instrumentation shall be capable of measuring, within the prescribed limits, the frequency and amplitude of the vibration conditions and the temperature conditions specified. When it is necessary to monitor fuze operation, instrumentation shall be used which is capable of measuring the necessary functions within the limits prescribed. Vibration amplitudes and frequencies shall be measured by techniques that will not significantly affect test item control or response. The input control sensing devices shall be rigidly attached to the vibration table, or to the intermediate structure, if used, at or as near as possible to the attachment points of the test fuze. The transverse motion shall be minimized and should be limited to the tolerances specified in Table B3-V.

B3.4.4 Vibration fixtures. Fixtures shall be designed to the criteria chart given in Table B3-V. The fixtures shall simulate the mounting of the fuze in its weapon, munition or munitions item. Equipment rigidly mounted in service shall be rigidly mounted to the test fixture. Equipment isolated in service shall use service isolators when mounted on the test fixture. If service isolators are not available during the qualification test, isolators shall be provided with characteristics such that the isolator/equipment resonant frequencies shall be between 20 Hz and 45 Hz with resonant amplification ratio between 3 and 5. The number of fuzes to be mounted on one fixture shall be a function of test management as long as the technical requirements of the fixture design and environmental conditions are maintained. Precautions shall be taken in the establishment of mechanical interfaces to minimize the introduction of undesirable responses in the test setup. The test load should be distributed uniformly on the vibration exciter table in order to minimize effects of unbalanced loads.

B3.5. PROCEDURE

B3.5.1 Introduction. Determine the test parameters as follows.

B3.5.1.1 Test procedure. This test includes four procedures, B3.5.3 through B3.5.6, corresponding to the four launch platforms described in B3.2.1. A complete test shall consist of performance of B3.5.1 and B3.5.2, as well as the applicable B3.5.3 through B3.5.6, in its entirety.

B3.5.1.2 Time schedule. Time schedules for each procedure shall be indicated in the applicable tables and figures.

B3.5.1.3 Selection of vibration test curves. Applicable vibration curves shall be selected from each procedure for the individual parts when the procedure is divided into parts. Selection of the curves shall be made to simulate the expected vibration environment for the particular vehicle or fuze involved.

B3.5.1.4 Fuze operation. Pre-test operation shall be in accordance with 4.3 in the General

Requirements Section of this Standard, or as required by the test plan or procurement specification. Operation during and after the test shall be as required by the test plan or procurement specification.

B3.5.1.5 Temperature levels. At least three temperature levels shall be specified over the range, reflecting the two range extremes and an intermediate level. At least one fuze shall be tested at each level, requiring, therefore, a minimum of three fuzes. When temperature limits are not called out in the following procedures or in the test plan or procurement specification, then $+71\pm 2^{\circ}\text{C}$, $+23\pm 10^{\circ}\text{C}$ and $-54\pm 2^{\circ}\text{C}$ ($+160\pm 4^{\circ}\text{F}$, $\pm 73\pm 18^{\circ}\text{F}$ and $-65\pm 4^{\circ}\text{F}$) shall be used for the three levels.

B3.5.2 Test Techniques.

B3.5.2.1 Vibration levels. The test levels specified herein (sinusoidal or random) shall be imparted to the fuze at its attachment points to the test fixture.

B3.5.2.2 Test fuze orientation. The vibration environment, specified by the curve selected from applicable tables in accordance with B3.5.1, shall be applied to each of the three mutually perpendicular axes of the test fuze in turn, unless otherwise specified. These axes shall be identified by the test plan or procurement specification.

B3.5.2.3 Sinusoidal vibration. The vibration shall be applied sequentially along each of the three mutually perpendicular axes of the fuze. The vibratory schedules and test times shall be according to the applicable figures and tables per the fuze application. The vibratory acceleration levels, or double amplitudes of the specified test curves, shall be maintained as vibratory inputs to the test item at the test item mounting points. When the input vibration is measured at more than one control point, the control signal shall be the average of all the control accelerometers' signals (see also B3.5.2.4c), unless otherwise specified. For massive test items, fixtures and all large force exciters, it is recommended that the input control level be an average of at least three inputs.

B3.5.2.3.1 Resonance search. This is applicable to Tables B3-III and B3-IV. Resonant frequencies of the fuze shall be determined by varying the frequency of applied vibration slowly through the specified range at reduced test levels, but, with sufficient amplitude to excite the fuze. Sinusoidal resonance search may be performed using the test level and cycling time specified for sinusoidal cycling tests, provided the resonance search time is included in the required cycling test time of B3.5.2.3.3.

B3.5.2.3.2 Resonance dwell. This is applicable to Tables B3-III and B3-IV. The fuze shall be vibrated along each axis at the most severe resonant points determined in B3.5.2.3.1. Test levels, frequency ranges, and test time shall be in accordance with the applicable conditions from the tables and figures for each fuze category. If more than four significant resonance points are found for any one axis, the four most severe points (usually those with highest amplification of input) shall be chosen for the dwell test. If a change in the resonant point occurs during the test, its time of occurrence shall be recorded, and, immediately, the frequency shall be adjusted to maintain the peak resonance condition. The final resonant frequency shall be recorded.

B3.5.2.3.3 Cycling. The fuze shall be vibrated along each axis in accordance with the test levels, frequency ranges, and times from the applicable tables and figures. The frequency of applied vibration shall be swept over the specified range in accordance with Figure B3-5. The specified sweep time is that of an ascending plus a descending sweep, and is twice the time shown on Figure B3-5 for the specified range. Linear sweep rates may be substituted for the logarithmic sweep rate. When linear sweep rates are used, the total frequency range shall be divided into logarithmic frequency bands with equal time intervals. Each time interval is the time of an ascending, plus a descending sweep for the band. The sum of these time intervals shall equal

MIL-STD-331C
w/CHANGE 1
APPENDIX B

the sweep time specified for the applicable frequency range. The linear sweep rate for each band is then determined by dividing each bandwidth in Hz by one-half the sweep time in minutes for each band. The logarithmic frequency bands may be readily determined from Figure B3-5. The frequency bands and linear sweep rates shown in Table B3-VI shall be used for the 2 (or 5) to 500 Hz and 5 to 2,000 Hz frequency ranges. For test frequency ranges of 100 Hz or less, no correction of the linear sweep rate is required.

B3.5.2.4 Random vibration. The vibration shall be applied sequentially along each of the three mutually perpendicular axes of the fuze. The vibratory schedules and test times shall be according to the curves and schedules from the applicable figures and tables by fuze application. The instantaneous random vibration acceleration peaks may be limited to three times the rms acceleration level. The power spectral density of the test control signal shall not deviate from the specified requirements by more than +100, -30 percent (+3, -1.5 dB) below 500 Hz and +100, -50 percent (± 3 dB) between 500 Hz and 2,000 Hz, except that deviations as large as +400, -75 percent (± 6 dB) shall be allowed over a cumulative bandwidth of 100 Hz maximum, between 500 and 2,000 Hz.

Tolerance levels in terms of dB are defined as:

$$dB = 10 \log_{10} \frac{W_1}{W_0}$$

where W_1 = measured acceleration power spectral density in g^2/Hz units and W_0 defines the specified level in g^2/Hz units. Confirmation of these tolerances shall be made by use of any analysis system providing statistical accuracies corresponding to a bandwidth-time constant product, $BT = 50$, minimum. Specific analyzer characteristics shall be as specified below or equivalent, subject to the $BT = 50$, $T - 1$ minimum limitation.

- a. On-line continuous filter, equalization/analysis system having a bandwidth as follows:
 1. $B = 25$ Hz, maximum between 20 to 200 Hz;
 2. $B = 50$ Hz, maximum between 200 to 1,000 Hz;
 3. $B = 100$ Hz, maximum between 1,000 to 2,000 Hz.
- b. Swept frequency analysis systems characterized as follows:
 1. Constant bandwidth analyzer
 - a) Filter bandwidth as follows:
 - 1) $B = 25$ Hz, maximum between 20 to 200 Hz;
 - 2) $B = 50$ Hz, maximum between 200 to 1,000 Hz;
 - 3) $B = 100$ Hz, maximum between 1,000 to 2,000 Hz;
 - b) Analyzer averaging time = $T = 2 RC = 1$ second minimum, where T = True averaging time and RC = analyzer time constant;
 - c) Analyzer sweep rate (linear) = $B/4RC$ or $B^2/8$ (Hz/second) maximum, whichever is smaller;
 2. Constant percentage bandwidth analyzer
 - a) Filter bandwidth = $pf_c =$ one tenth of center frequency maximum ($0.1 f_c$), where p = percentage and f_c = analyzer center frequency;
 - b) Analyzer averaging time = $T = 50/pf_c$ minimum;
 - c) Analysis sweep rate (logarithmic) = $pf_c/4RC$ or $(pfc)^2/8$ (Hz/second), maximum, whichever is smaller.

- c. Digital power spectral density analysis system. This system shall employ quantization techniques providing accuracies commensurate with the above approach. Accelerometers employed for test level control shall be mounted in accordance with B3.4.3. Where more than one accelerometer is employed for test level control, the arithmetical average of the power spectral densities indicated by the control accelerometers shall be used for control of the test level.

B3.5.2.5 Temperature conditioning. Unless directed otherwise, the fuze shall be preconditioned a sufficient length of time to ensure that the entire fuze has reached the test temperature level. This can be determined by monitoring interior portions of the fuze, or by using predetermined testing or calculation of the thermal response. Once the temperature level has been reached, the temperature of air, or medium surrounding the fuze, shall be maintained at the specified test temperature level for the period of the test. For tests which are to simulate short periods of temperature gradient conditions of the ambient air or the fuze surface, temperature monitoring shall be established to ensure that the gradient is achieved by the temperature conditioning equipment.

B3.5.2.6 Fuze assembly to fixture. In the assembly of fuzes to the test fixture, care shall be given to utilizing proper procedures. The fuze shall remain tight in the fixture in order to receive a valid test, since the shock imparted to a loose fuze may be significantly magnified. If a fuze becomes loose during a test, it should be ruled invalid.

B3.5.3 Air-launched munitions. This includes external-carry applications, excluding helicopters.

B3.5.3.1 Part A. Pre-launch (captive flight) vibration- temperature. The fuze shall be attached to the vibration exciter according to B3.4.4, and shall be subjected to broadband random vibration excitation in the manner prescribed in B3.5.2.4. The power spectral density tolerances of applied vibration shall be as indicated therein. Two test levels are specified: an endurance test level, and a functional test level for those fuzes which are required to be operating during a captive flight condition. For each axis, the endurance test shall be conducted first, followed by the functional test where applicable. The fuze shall be operated during the functional test and shall perform according to the test plan or procurement specification. The applied vibration shall be according to the test conditions of Table B3-I and the curve of Figure B3-1. The time durations and other test conditions shall be determined from the test level equations and other parameter values from Table B3-I. If the computed functional and endurance ($T=1$) test levels (W_2) are less than $0.04 \text{ G}^2/\text{Hz}$, use $W_2 = 0.04 \text{ G}^2/\text{Hz}$, and $T = 1$ for the endurance test.

B3.5.3.2 Part B. Free-flight vibration-temperature. For weapons that are deployed by separation from the aircraft (free-flight) such as bombs and missiles, a free-flight functional test shall be conducted in addition to the captive flight test of B3.5.3.1. The fuze shall be attached to the vibration exciter according to Section B3.4.4, and shall be subjected to the broadband random vibration excitation in the manner prescribed in B3.5.2.2. The applied vibration shall be according to the functional test conditions of Table B3-I and the curve of Figure B3-1. The time durations and other test conditions shall be determined from the test level equations and other parameter values in Table B3-I, except: (a) factors A_1 , A_2 , and $(N/3T)$ shall be set equal to one, (b) the value of q shall be the maximum value attainable during free-flight, and (c) the duration of this test, per axis, shall equal the maximum free-flight time expected at maximum q , but not less than 30 seconds. The fuze shall be energized and operated according to the test plan or procurement specification while under vibration to determine conformance to the criteria of B3.3. In the event that all free-

flight functional checks are made during the captive functional test, and the captive functional test levels are larger or equal to those derived here, no free-flight functional test is required.

B3.5.4 Ground-launched munitions. Artillery fuzes are excluded.

B3.5.4.1 Part A. Pre-launch vibration-temperature. The fuze shall be attached to the vibration exciter according to B3.4.4, and shall be subjected to sinusoidal vibration excitation in the manner prescribed in B3.5.2.3. The acceleration or displacement of the applied vibration shall be according to one specified curve P through U of Figure B3-2, with the selection of subpart 1, 2, 3, or 4 in Table B3-II, depending on whether the fuze is installed with or without vibration isolators. The curve selections, time durations and other test conditions shall be determined from Table B3-II. Those fuzes which are required to be operating prior to launch shall be energized and operated according to the test plan or procurement specification while under vibration.

B3.5.4.2 Part B. Free-flight vibration-temperature. The fuze shall be attached to the vibration exciter according to B3.4.4, and shall be subjected to broadband random vibration excitation in the manner prescribed in B3.5.2.4. The applied vibration shall be according to one specified curve AE through AP from Figure B3-2, with the selection of subpart 1, 2 or 3 in Table B3-II, depending on whether the fuze is installed with or without vibration isolators. The curve selections, time duration and other test conditions shall be determined from Table B3-II. The fuze shall be energized and operated according to the test plan or procurement specification while under vibration to determine conformance to the criteria of B3.3.

B3.5.5 Ship-launched munitions.

B3.5.5.1 Part A. Pre-launch vibration-temperature. The fuze shall be attached to the vibration exciter according to B3.4.4, and shall be subjected to sinusoidal vibration excitation in the manner prescribed in B3.5.2.3. The acceleration (or displacement) and test levels and duration of the applied vibration shall be according to Table B3-III. Those fuzes which are required to be operating prior to launch shall be energized and operated according to the test plan or procurement specification while under vibration.

B3.5.5.2 Part B. Free-flight vibration-temperature. The fuze shall be attached to the vibration exciter according to B3.4.4, and shall be subjected to broadband random vibration excitation as directed in B3.5.2.4. The applied vibration shall be according to one specified curve AE through AP from Figure B3-3. The time durations and other test conditions shall be determined from the Tables of Figure B3-3. The fuze shall be energized and operated while under vibration according to the test plan or procurement specification to determine conformance to the criteria of B3.3.

B3.5.6 Underwater-launched munitions.

B3.5.6.1 Part A. Pre-launch vibration temperature. The fuze shall be attached to the vibration exciter as directed in B3.4.4, and shall be subjected to sinusoidal vibration excitation in the manner prescribed in B3.5.2.1. The frequency ranges, acceleration (or displacement) test levels and duration of the applied vibration shall be according to Table B3-IV, Part A. The temperature levels of the fuze while under vibration shall be $+35\pm 2^{\circ}\text{C}$, $+23\pm 10^{\circ}\text{C}$ and $-3\pm 1^{\circ}\text{C}$ ($+95\pm 4^{\circ}\text{F}$, $+73\pm 18^{\circ}\text{F}$ and $+27\pm 2^{\circ}\text{F}$). Those fuzes which are required to be operating prior to launch shall be energized and operated according to the test plan or procurement specification while under vibration to determine conformance to the criteria of B3.3.

B3.5.6.2 Part B. Post-launch vibration-temperature for underwater-launched missiles that complete their free-flight mission in air. This test simulates the mission period from launch tube exit to the sea surface. The fuze shall be attached to the vibration exciter as directed in B3.4.4, and shall be subjected to vibration levels and duration as determined by the parent

weapon's test plan or procurement specification. If test plan or procurement specification are not specified, subject the fuze to sinusoidal vibration excitation in the manner prescribed in B3.5.2.1. In this case the frequency ranges, acceleration (or displacement) test levels and duration of applied vibration shall be according to Figure B3-4A. The temperature levels of the fuzes while under vibration shall be $+35\pm 2^{\circ}\text{C}$, $+23\pm 10^{\circ}\text{C}$ and $-3\pm 1^{\circ}\text{C}$ ($+95\pm 4^{\circ}\text{F}$, $+73\pm 18^{\circ}\text{F}$ and $+27\pm 2^{\circ}\text{F}$). Those fuzes which are required to be operated while under these launch conditions shall be energized and operated while under vibration to determine conformance to the criteria of B3.3.

B3.5.6.3 Part C. Free-flight vibration-temperature for weapons whose free-flight is in water only. The fuze shall be attached to the vibrator exciter according to Paragraph B3.4.4. For battery propulsion type weapons, the fuze shall be subjected to sinusoidal vibration excitation in the manner prescribed in B3.5.2.1. The frequency ranges, acceleration (or displacement) test levels and duration of the applied vibration shall be according to Table B3-IV, Part B. For other type propulsion the fuze shall be subjected to broadband random vibration excitation in the manner prescribed in B3.5.2.2. The applied vibration shall be according to the specified curve from Figure B3-4B. The fuze shall be energized and operated while under vibration according to test plan or procurement specification to determine conformance to the criteria of B3.3.

B3.5.6.4 Part D. Free-flight vibration-temperature for weapons whose free-flight is in air only. The fuze shall be attached to the vibration exciter according to B3.4.4, and shall be subjected to broadband random vibration excitation as directed in B3.5.2.2. The applied vibration shall be according to one specified curve AC through AP from Figure B3-3. The time durations and other test conditions shall be determined from the tables of Figure B3-3. The fuze shall be energized and operated while under vibration according to the test plan or procurement specification to determine conformance to the criteria of B3.3.

B3.6. ALTERNATE AND OPTIONAL TESTS

None.

B3.7. RELATED INFORMATION

B3.7.1 Tactical simulation. The vibration-temperature conditions of this test represent service conditions in tactical usage as monitored in a variety of geographical locations and weapon or munition types. As a standard test, it is considered to provide simulation of tactical service use conditions for qualification of fuze designs under the vibration-temperature environment. There will be exceptions to this among fuze designs; therefore, usage of each fuze shall be carefully investigated to determine whether this standard applies.

B3.7.2 Compatibility with MIL-STD-810. This test is equivalent, in most parameters, to Test Method 514 of MIL-STD-810, Environmental Test Methods, for the tactical vibration environment of air-launched and certain ground-launched, and underwater-launched fuze applications. Additionally, by combining temperature with the vibration environment, the test provides the opportunity to assess the effects of two environments, often critical to the operation of fuzes during their tactical life.

B3.7.3 Helicopter vibration. At the present, there is insufficient data to establish a standard vibration schedule.

B3.7.4 Artillery fuzes. For artillery fuzes, the pre-launch vibration environment is generally insignificant. At present, there is insufficient data to establish a standard vibration test for the post-launch condition.

B3.7.5 Ship-launched applications. The vibration conditions for Section B3.5.5 are taken

from the conditions specified in MIL-STD-167-1 for Type I vibrations. These conditions apply to “all equipment intended for shipboard use or be capable of withstanding the environmental vibration conditions which may be encountered aboard naval ships (B3.1.3).” Thus, ship-mounted and ship-carried munitions items will encounter the same driving conditions of vibration forces, but may react differently as a function of the transmissibility of the “mounting” or attachment structure. For fuzes, assembled to a parent vehicle or munitions, this will be a function of mounting racks, loading machinery and launching equipment installations.

B3.7.6 Tank vibration. Tank and similar weapon system vibration schedules are included in transportation type testing. It has generally been noted that the vibration levels and frequencies are more severe on cartridge interfaces than fuze components.

B3.7.7 Internally-carried aircraft munitions. This test does not cover fuzes for this type of munitions.

B3.7.8 Bibliography.

AFFDL-TR-71-158, *Vibration and Acoustic Test Criteria for Captive Flight of Externally Carried Aircraft Stores*, December 1971.

TABLE B3-1. Vibration Criteria for Externally-Carried, Air-Launched Ordnance (Excluding Helicopter Ordnance)

Parametric Equations for Figure B3-1

$$\text{Eq (1)} : W_1 = (5)(10^{\frac{-3}{1,2}})(N/3T)^{\frac{1}{4}}(A_1)(B_1)(C_1)(D_1)(E_1)^2 \text{ Hz}$$

$$\text{Eq (2)} : W_2 = (5)(10^{\frac{-5}{1,2}})(q/\rho)^2 (N/3T)^{\frac{1}{4}}(A_2)(B_2)(C_2)(D_2)(E_2)^2 \text{ Hz}$$

$$\text{Eq (3)} : f_1 = 10^{\frac{3,4}{5}} (t/R)^{\frac{2}{2}} \text{ Hz}$$

$$\text{Eq (4)} : f_2 = f_1 + 1000 \text{ Hz}$$

MIL-STD-331C
w/CHANGE 1
APPENDIX B

Location, Configuration, Special Adjustments		
	A_1	A_2
Tri-ejection rack (TER) cluster mount	1	2
Multiple ejection rack (MER) cluster mount	2	4
Single station	1	1
	B_1	B_2
Aft half of air-fired missiles	1	4
Aft half of all other stores	1	2
forward half of all stores	1	1
	C_1	C_2
Blunt-nosed stores, single station and TER	2	4
Blunt-nosed stores, MER	1	2
All other stores	1	1
	D_1	D_2
Free-fall munitions with nonintegral finned sheet metal tail cones	8	16
Air-fired missiles	1	1
All other stores	4	4
	E_1	E_2
Firebombs (jelly filled)	1/2	1/4
All other conditions	1	1

Definitions

q = Maximum flight dynamic pressure in lbs/ft² (Note 1)

ρ = Average store weight density in lbs/ft³ (total weight + total volume)

t = Local store average skin thickness where R is measured (inches)

R = One-half the average of the major and minor diameters (inches) for a store with an elliptical cross-section (for cylindrical sections, use local geometry; for conical sections, use smallest f_1 calculated using geometry within one foot of equipment mounting point; for cast irregular shaped cross section, R shall be one-half the longest inscribed cord for monocoque irregular cross-section $f_1 = 300$ Hz).

N = Maximum number of anticipated service missions (functional test, $N = 3$; endurance test $N \geq 3$).

T = Test time per axis in hours (functional test, $T = 1$; endurance test, $T \geq 1$).

TABLE B3-1. Vibration Criteria for Externally-Carried, Air-Launched Ordnance (Excluding Helicopter Ordnance) (Continued).

Representative Parameter Values To Be Used For Captive Notes

MIL-STD-331C
w/CHANGE 1
APPENDIX B

Flight When Specific Parameters Are Not Available

Store Type	Max q	ρ	N endur- ance	T endur- -ance	f_1 (Hz)	f_2 (Hz)
Missile, air to ground	1600	100	3	none	500	1500
Missile, air to air	1600	100	100	1	500	1500
Instrument pod	1800	50	500	1	500	1500
Dispenser (reusable)	1200	50	50	1	200	1200
Demolition bomb	1200	120	3	none	125	2000
Fire bomb	1200	40	3	none	100	1100

1. For endurance test, $q = 1200$ PSF or maximum q , whichever is less. For functional test, $q = 1800$ lbs/ft² or maximum q , whichever is less.
2. If functional test level is equal to or larger than the endurance test level when $T = 1$, no endurance test is required, except as noted in B3.5.3.1.
3. Free-fall stores with tail fins, used $f_1 = 125$ Hz; $F_2 = 10^5 (t/R_2) + 1000$ Hz.
4. For general use fuzes which can be used in several stores; use $W_1 = 0.04g_2/Hz$; $W_2 = 0.15 g_2/Hz$; $f_1 = 100$ Hz; $f_2 = 1000$ Hz; $T = 20$ min/axis.
5. Acceptance range for parameter values: $40 < \rho > 150$ $0.001 t/R_2 < .02$ If calculated values fall outside these limits, use these limit values.

MIL-STD-331C
w/CHANGE 1
APPENDIX B

TABLE B3-II. Vibration Test Schedules For Ground-Launched Munition Fuzes (excluding artillery).

A. Test Parts, Sub-Parts And Schedules

Vibration isolators Used in Mounting Configuration	Para B3.5.4.1 Part	Para B3.5.4.1 Sub-part	Test Time Per Axis			Curve (Note 1)
			Sinusoidal Cycling Time (Para. B3.5.4.1)	Sweep Time 5 to 2000 to 5 cps	Random Time (Note 3) (Para B3.5.4.2)	
No	A	1	30 min	20 min		One of P thru U
No	B	1			30 min	One of AE thru AP
Yes (Note 2)	A	2	30 min	20 min		One of P thru U
Yes (Note 2)	A	3	30 min	20 min		N
Yes (Note 2)	B	2			30 min	One of AE thru AP
Normally yes, but tested without	A	4	30 min	20 min		N
Normally yes, but tested without	B	3			30 min	AE

Notes:

1. For sinusoidal vibration, resonance tests and cycling tests of items mounted in missiles and weighing more than 80 lbs, the vibrator accelerations shall be reduced by $\pm 1g$ for each 20-pound increment of weight over 80 lb. However, the vibratory acceleration shall in no case be less than 50 percent of the specified curve level.
2. Test items of equipment normally provided with vibration isolators first shall be tested with the isolators in place (Part A). The isolators then shall be removed and the test item rigidly mounted and subjected to the test level indicated (Part A3). Isolators shall be replaced with the test item subjected to the test level indicated for Part B2.
3. When flight distances of missiles are less than 100 miles, the test time is reduced to 5 min. For rockets, projectiles and free-fall weapons, the test time is reduced to 3 min.

B. Curve Selection Chart

Equipment by Vehicle Section	Approximate Thrust to Weight Ratio or Thrust in Pounds	Vibration Test Curves	
		Sinusoidal	Random
All except booster	All	P or Q	AE, AF or AG
By individual booster state	250,000 lbs or less	Q or R	AH, AJ or AK
	250,000 lbs to 500,000 lbs	R or S	AK, AL or AM
	Over 500,000 lbs	T or U	AM, AN or AP

TABLE B3-III. Sinusoidal Vibration Frequencies, Vibration Levels And Test Times For Fuzes Installed In Ship -Launched Munitions Underwater-

Frequency Range (Hz)	Displacement (Inches peak to peak)
5 to 15	0.060±0.012
16 to 25	0.040±0.008
26 to 33	0.020±0.004
34 to 40	0.010±0.002
41 to 50	0.005±0.001

NOTES: (Apply to Tables B3-III and B3-IV)

1. Vibrate 5 minutes per axis at each discrete frequency in the range.
2. Vibrate 2 hours per axis at the resonant frequency with the highest transmissibility or at 50 Hz if no resonant frequency is observed at the amplitudes shown.

TABLE B3-IV. Sinusoidal Frequencies, Levels And Test Time For Fuzes Installed In

Launched Munitions

A. Pre-Launch Vibration Conditions

Frequency Range (Hz)	Displacement (Inches peak to peak)
5 to 15	0.060±0.012
16 to 25	0.040±0.004
26 to 33	0.020±0.004
34 to 40	0.010±0.002
41 to 50	0.005±0.001

B. Free-Flight Vibration Conditions

Frequency Range (Hz)	Amplitude (g)	Duration (min)
10 to 60	1±0.1	15
61 to 150	1±0.1	15

MIL-STD-331C
w/CHANGE 1
APPENDIX B

TABLE B3-V. Design Criteria Chart For Various Sizes Of Fixtures For Vibration Testing

	Allowable Transmissibility Peaks	Allowable Orthogonal Motion	Allowable Variation in Vibratory Input between Test Item Attachment Points
Fuzes in sizes up to 5-in cube and weights up to 5 lb.	None below 1,000 Hz. Above 1,000 Hz, a maximum of 3 resonances, limited to 5:1 over 3 dB bandwidth of 1,000 Hz.	Y and Z motions less than X motion throughout the test range up to 2,000 Hz.	±20% allowable up to 1,000 Hz. From 1,000 to 2,000 Hz, 50%.
Fuzes in sizes up to a 10-in cube and weights up to 15 lbs.	None below 1,000 Hz. Maximum of 4 peaks above 1,000 Hz 5:1. None to exceed a 3 dB bandwidth of 100 Hz.	Y and Z motions less than X motion throughout the test range up to 2,000 Hz.	±30% up to 1,000 Hz. 1,000 to 2,000 Hz, not to exceed 2:1 between any pair of points.
Odd shaped fuzes with volumes up to 3 cu ft, weights 10 to 50 lb.	None below 800 Hz. Maximum 4 peaks 6:1 over 3 dB bandwidth 100 Hz, 800 to 1,500 Hz. Maximum 3 peaks 8:1 over 3 dB bandwidth of 125 Hz, 1,500 to 2,000 Hz.	Y and Z motions less than X motion up to 1,000 Hz. Above 1,000 Hz, 2x, except that over a 3 dB bandwidth of 200 Hz, may be 3x.	±50% up to 1,000 Hz. From 1,000 to 2,000 Hz, 2:1, except that over a 3 dB bandwidth of 200 Hz, input variation may be 2.5:1 between any pair of points.
Larger fuzes with volumes over 3 cu ft and weights over 50 lb.	None below 500 Hz. Maximum 2 peaks 6:1 over 3 dB bandwidth 125 Hz. 500 to 1,000 Hz. Maximum 3 peaks 8:1 over 3 dB bandwidth 150 Hz, 1,000 to 2,000 Hz.	Y and Z less than x to 500 Hz. 500 to 1,000 Hz, less than 2x, and 1,000 to 2,000 Hz, less than 2.5x, except over a 3 dB bandwidth of 200 Hz, may be 3x.	±50% up to 500 Hz. From 500 to 1,000 Hz, 2:1 and 1,000 to 2,000 Hz, 2.5:1, except over 3dB bandwidth of 200 Hz, variation may be 3:1.

MIL-STD-331C
w/CHANGE 1
APPENDIX B

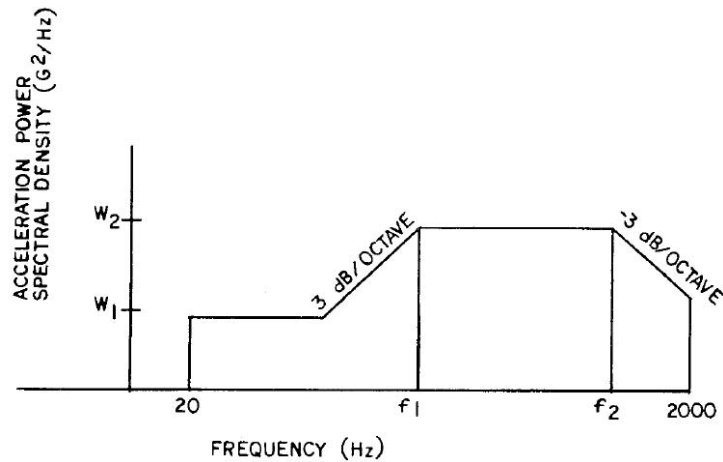
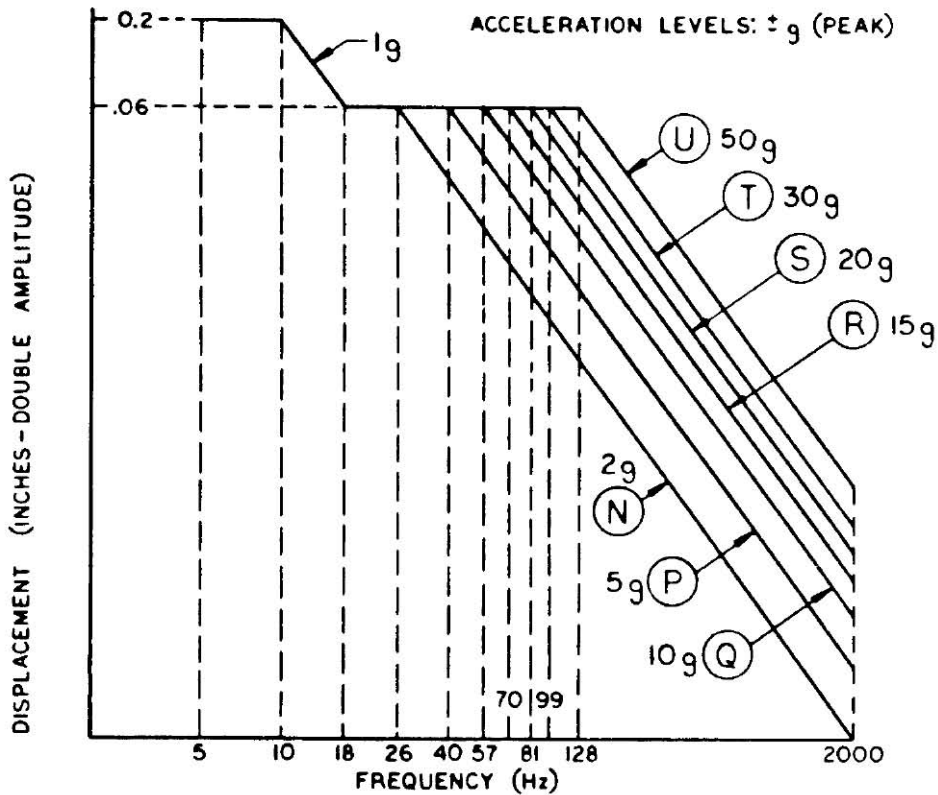

FIGURE B3-1. Vibration Test Levels For Externally-Carried, Air-Launched Munition (excluding helicopters)

TABLE B3-VI. Linear Cycling Rates

Total Frequency Range (Hz)	Frequency Band (Hz)	Sweep Time in Minutes	Linear Cycling Rate (Hz/min)
2 to 500 or 5 to 500 as applicable	2 to 5	3	2
	5 to 22.5	6	5.8
	22.5 to 110	5	35
	110 to 500	4	195
5 to 2,000	5 to 22.5	6	5.8
	22.5 to 110	5	35
	110 to 500	4	195
	500 to 900	3	267
	900 to 2,000	2	1,000

SINUSOIDAL VIBRATION CURVES



RANDOM VIBRATION CURVES

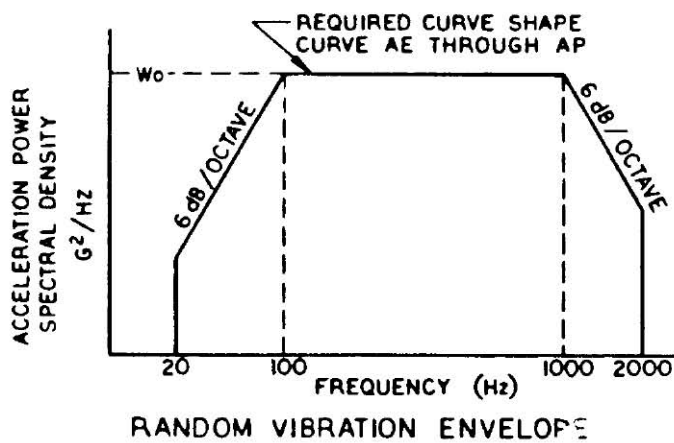

TEST CURVE	ACCELERATION POWER SPECTRAL DENSITY W ₀ (G ² /HZ)	COMPOSITE G-RMS MINIMUM
AE	0.02	5.4
AF	0.04	7.6
AG	0.06	9.3
AH	0.10	12.0
AJ	0.20	16.9
AK	0.30	20.7
AL	0.40	23.9
AM	0.60	29.3
AN	1.00	37.9
AP	1.50	46.4

NOTE: COMPOSITE G-rms = $\left[\int_{f_1}^{f_2} W(f) df \right]^{1/2}$

WHERE f_1 AND f_2 ARE THE LOWER AND UPPER TEST FREQUENCY LIMITS RESPECTIVELY, $W(f)$ IS THE ACCELERATION POWER SPECTRAL DENSITY IN G^2/HZ UNITS.

FIGURE B3-2. Vibration Test Curves For Fuzes Installed In Ground-Launched Munition (excluding artillery)

MIL-STD-331C
w/CHANGE 1
APPENDIX B

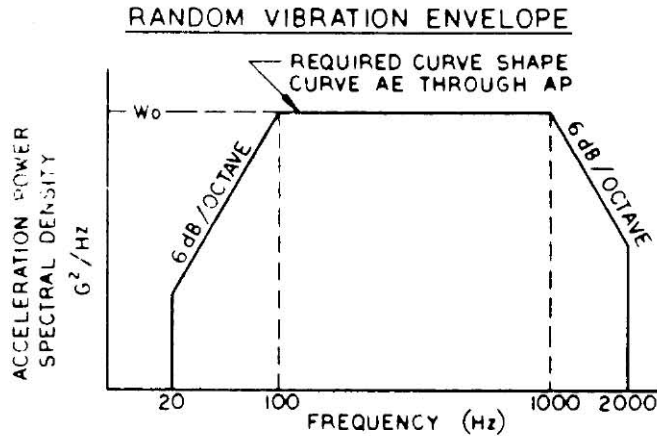

TEST CURVE	ACCELERATION POWER SPECTRAL DENSITY W ₀ (G ² /Hz)	COMPOSITE G-RMS MINIMUM
AE	0.02	5.4
AF	0.04	7.6
AG	0.06	9.3
AH	0.10	12.0
AJ	0.20	16.9
AK	0.30	20.7
AL	0.40	23.9
AM	0.60	29.3
AN	1.00	37.9
AP	1.50	46.4

NOTE: COMPOSITE G-rms = $\left[\int_{f_1}^{f_2} w(f) df \right]^{1/2}$

WHERE f_1 AND f_2 ARE THE LOWER AND UPPER TEST FREQUENCY LIMITS RESPECTIVELY. $w(f)$ IS THE ACCELERATION POWER SPECTRAL DENSITY IN G²/Hz UNITS.

EQUIPMENT LOCATION BY VEHICLE SECTION	APPROXIMATE THRUST TO WEIGHT RATIO OR THRUST IN POUNDS	RANDOM VIBRATION CURVES
ALL EXCEPT BOOSTER	ALL 250,000 LBS OR LESS	AE, AF OR AG AH, AJ OR AK
BY INDIVIDUAL BOOSTER STAGE	250,000 LBS TO 500,000 LBS OVER 500,000 LBS	AK, AL OR AM AM, AN OR AR

TEST TIME SCHEDULE (PER AXIS)

EQUIPMENT MOUNTING CONFIGURATION	RANDOM TIME (NOTE)	CURVE
WITHOUT VIBRATION ISOLATORS	30 MIN	ONE OF AE THRU AP
WITH VIBRATION ISOLATORS	30 MIN	ONE OF AE THRU AP
NORMALLY WITH VIBRATION ISOLATORS BUT TESTED WITHOUT ISOLATORS	30 MIN	AE

NOTE: WHEN FLIGHT DISTANCES OF MISSILES ARE LESS THAN 100 MILES, THE TEST TIME IS REDUCED TO 5 MINUTES. FOR ROCKETS, PROJECTILES AND OTHER SHORT FLIGHT WEAPONS THE TEST TIME IS REDUCED TO 1 (ONE) MINUTE.

FIGURE B3-3. Random Vibration Frequencies, Levels And Test Times For Fuzes Installed In Shipboard-Launched Munitions

MIL-STD-331C
w/CHANGE 1
APPENDIX B

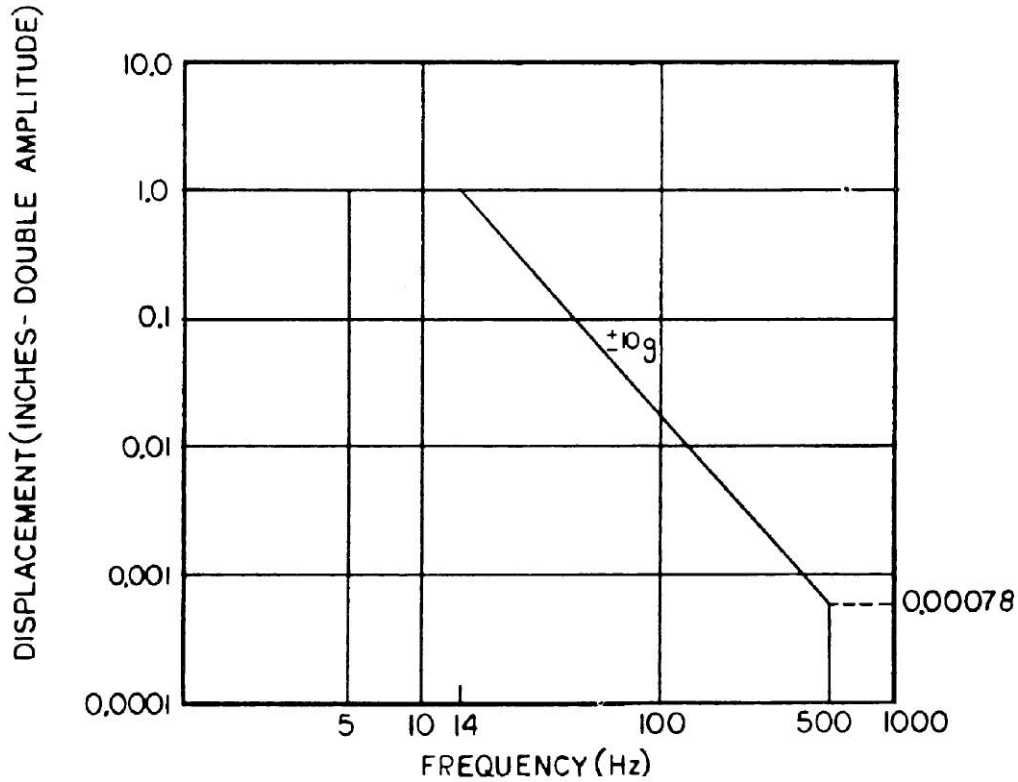

NOTE:
THIS ENVIRONMENT IS CAUSED BY THE CAPSULE EXITING
THE TORPEDO TUBE AND RISING TO THE SURFACE.

FIGURE B3-4A. Submarine-To-Surface Induced Sinusoidal Vibration

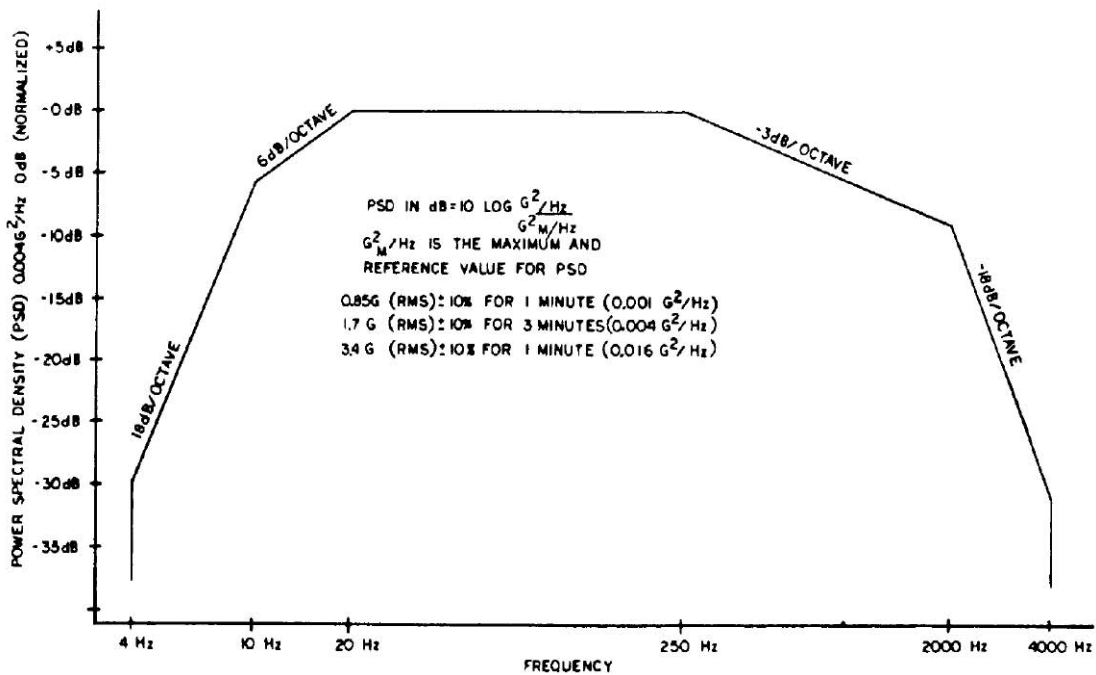

FIGURE B3-4B. Random Vibration Frequencies, Levels And Test Times For Fuzes

Installed In Underwater-Launched Munitions

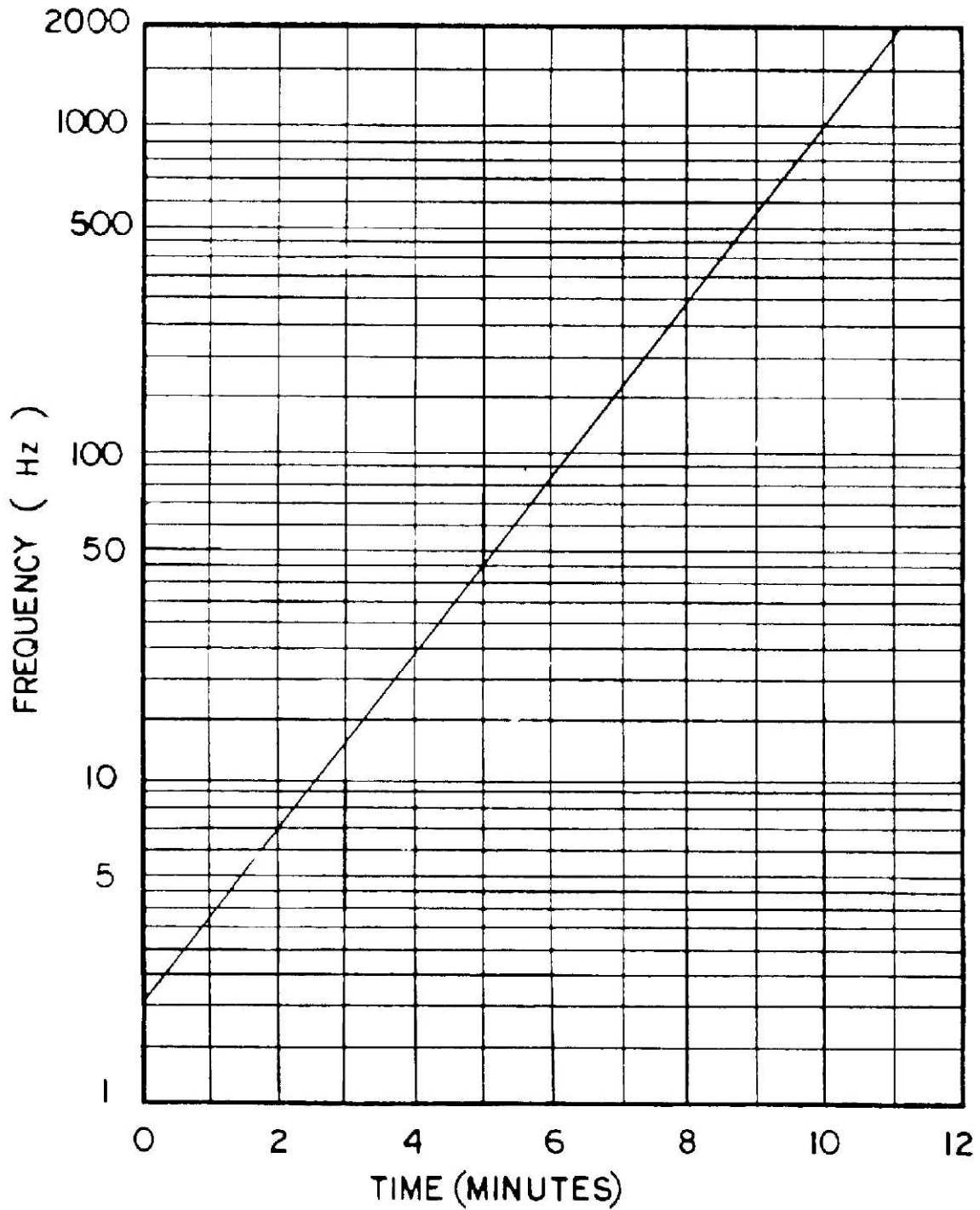

FIGURE B3-5. Logarithmic Frequency Sweep

**APPENDIX C
CLIMATIC TESTS**

TEST C1

TEMPERATURE AND HUMIDITY

C1.1 PURPOSE

This is a laboratory safety and reliability test simulating storage conditions. The fuze must withstand exposure to repeated cycles of extreme temperatures and humidity.

C1.2 DESCRIPTION

C1.2.1 General. Bare fuzes are exposed to a 28-day schedule (two 14-day cycles) of temperature and humidity variations. Fuzes are alternately exposed to extremes of +71°C and -54°C (+160°F and -65°F) with additional storage periods at +71°C and -62°C (+160°C and -80°F). The test chamber is maintained at 95 percent relative humidity during the +71°C (+160°F) periods. There are two methods for performing this test using either one or two test chambers. In the two-chamber method, fuzes are moved from a cold to a hot chamber and back. In the single-chamber method, the temperature within the chamber is changed nine times, exposing the fuzes to a similar schedule of temperatures.

C1.2.2 Test fuzes. All explosive elements shall be present in the fuze during the test.

C1.2.3 Applicable publications. All standards, specifications, drawings, procedures and manuals which form a part of this test are listed in Section C1.2 of the introduction to this standard. Special attention is directed to Army Regulation 70-38 regarding material testing for extreme climatic conditions.

C1.2.4 Test documentation. Test plans, performance records, equipment, conditions, results and analysis shall be documented in accordance with 4.8 of the general requirements to this standard.

C1.3. CRITERIA FOR PASSING TEST

C1.3.1 Fuze condition. At the completion of this test, the fuze shall be safe for transportation, storage, handling and use, as well as operable in accordance with 4.6.2.1a and 4.6.2.2 of the general requirements to this standard.

C1.3.2 Decision basis. Breakdown, inspection, other appropriate tests and engineering judgment shall form the basis for the decision that fuzes have passed or failed the test. Fuzes may be subjected to operational tests under simulated field conditions.

C1.4 EQUIPMENT

C1.4.1 Test chambers. Commercial temperature-humidity chambers or cabinets are used for this test. The humidity chamber and accessories shall be constructed to avoid condensate dripping on the test items and to prevent the build-up of total pressure. The flow of air throughout the internal test chamber area shall not exceed 45.7 meters per minute (150 feet per minute). No rust or corrosive contaminants shall be imposed on the test items by the test facility.

C1.4.2 Fixtures. If fixtures are used to hold the fuzes in particular orientations, they must not impede the entrance of moisture and interference with the attainment of equilibrium shall be minimized.

C1.4.3 Temperature. The term "temperature" used throughout this test is defined as the temperature of the air immediately surrounding the control sensing elements. Continuous records of temperature and humidity or wet bulb are required. When the single-chamber method is used, the continuous recording requirement for humidity or wet bulb shall apply only to those portions of the test schedule that are above room temperature. A sampling type of recording system, such as a multi-point recorder, shall be considered as providing a continuous record if each variable is recorded not less than once every two minutes.

C1.5. PROCEDURE

C1.5.1 Schedule. Perform this test in accordance with the schedule in Table C1-I for the two-chamber method or Table C1-II for the single-chamber method, whichever is appropriate, observing the indicated temperature sequence and duration of each event. Changes must be made within 15 minutes of the times indicated. The tables show the day count and time of day when it should be most convenient to run each event. Figure C1-1 is a graphic representation of the test schedule.

C1.5.2 Return to ambient temperature. At the end of 28 days (two complete 14-day cycles) allow the fuzes to return to room ambient conditions. Room temperature is $+23^{\circ}\text{F}\pm 10^{\circ}\text{C}$ ($+73^{\circ}\text{F}\pm 18^{\circ}\text{F}$).

C1.5.3 Compliance. Analyze the test results and determine whether or not the test article meets the pass/fail criteria in Section C1.3. Continue testing the specified number of items.

C1.6. ALTERNATE AND OPTIONAL TESTS

None.

C1.7. RELATED INFORMATION

C1.7.1 Background of 14-day cycle. Various temperature and humidity cycles have been in use for many years with the result that no real correlation between test conditions and actual storage conditions can be drawn. The basic 14-day unit of this test, referred to as the "temperature and humidity cycle", may be useful for many other applications as well as for fuze testing. The 14-day cycle was originally chosen because this period is a little shorter than that required to cause failure of mercury fulminate detonators, which are no longer authorized for use. Current fuze designs should withstand two temperature and humidity cycles (28 days).

C1.7.2 Accelerated conditions. A relative humidity of 95% at the high temperature is used because damage to certain elements is accelerated in the presence of moisture. It has been found through experiment that, in the case of ordinary thread seals and other similar closures, moisture is transported into the interior of fuzes primarily through diffusion rather than through a "breathing process", although both occur. However, there have been instances where moisture entry could have occurred only during the cooling period. For instance, in one assembly, utilizing an "O" ring, a partial relief of the pressure difference (developed during cycling) occurred, a pressure differential being maintained after attainment of thermal equilibrium. In this situation, diffusion would be excluded as the process for moisture transport, and moisture entry

MIL-STD-331C
w/CHANGE 1
APPENDIX C

would occur only during the cooling period. Thus, the results obtained by imposing a slow cooling period with maintenance of high relative humidity would differ from those obtained when fuzes are allowed to cool at ambient humidity. Therefore, if a fuze has such seals, the designer should consider this point in running this test.

C1.7.3 Obtaining humidity. It is recommended that the specified humidity be obtained through the use of steam or by vaporizing distilled, demineralized or deionized water. The pH of a condensed sample of vapor from the test chamber is expected to be between 6.0 and 7.3 at +23°C (+73°F).

C1.7.4 Bibliography.

C1.7.4.1 Picatinny Arsenal Technical Report No. 1800, *Temperature and Humidity Test*.

C1.7.4.2 AR 70-38, *Research, Development, Test and Evaluation of Materiel for Extreme Climatic Conditions*.

MIL-STD-331C
w/CHANGE 1
APPENDIX C

TABLE C1- I. Two-chamber Method Test Schedule

Day		Time		Temperature (degrees C)	Relative Humidity	Day		Time		Temperature (degrees C)	Relative Humidity
Cycle 1	Cycle 2	Start	Stop			Cycle 1	Cycle 2	Start	Stop		
1	15	0800	0900	Room		8	22	0900	1500	-54	
1	15	0900	1500	-54		8	22	1500	1600	Room	
1	15	1500	1600	Room		8-9	22-23	1600	0800	+71	95%
1-2	15-16	1600	0800	+71	95%	9	23	0800	0900	Room	
2	16	0800	0900	Room		9	23	0900	1500	-54	
2	16	0900	1500	-54		9	23	1500	1600	Room	
2	16	1500	1600	Room		9-10	23-24	1600	0800	+71	95%
2-3	16-17	1600	0800	+71	95%	10	24	0800	0900	Room	
3	17	0800	0900	Room		10	24	0900	1500	-54	
3	17	0900	1500	-54		10	24	1500	1600	Room	
3	17	1500	1600	Room		10-11	24-25	1600	0800	+71	95%
3-4	17-18	1600	0800	+71	95%	11	25	0800	0900	Room	
4	18	0800	0900	Room		11	25	0900	1500	-54	
4	18	0900	1500	-54		11	25	1500	1600	Room	
4	18	1500	1600	Room		11-12	25-26	1600	0800	+71	95%
4-5	18-19	1600	0800	+71	95%	12	26	0800	0900	Room	
5	19	0800	0900	Room		12	26	0900	1500	-54	
5-8	19-22	0900	0900	-62		12	26	1500	1600	Room	
						12-15	26-29	1600	0800	+71	95%

MIL-STD-331C
w/CHANGE 1
APPENDIX C

TABLE C1- II. Single-chamber Method Test Schedule

Day		Time		Temperature (degrees C)	Relative Humidity
Cycle 1	Cycle 2	Start	Stop		
1	15	0800	0900	Room	
1	15	0900	1100	Transition	
1	15	1100	1600	-54	
1	15	1600	1900	Transition	
1-2	15-16	1900	0800	+71	95%
2	16	0800	1100	Transition	
2	16	1100	1600	-54	
2	16	1600	1900	Transition	
2-3	16-17	1900	0800	+71	95%
3	17	0800	1100	Transition	
3	17	1100	1600	-54	
3	17	1600	1900	Transition	
3-4	17-18	1900	0800	+71	95%
4	18	0800	1100	Transition	
4	18	1100	1600	-54	
4	18	1600	1900	Transition	
4-5	18-19	1900	0800	+71	95%
5	19	0800	1100	Transition	
5-8	19-22	1100	0800	-62	
8	22	0800	1600	-54	
8	22	1600	1900	Transition	
8-9	22-23	1900	0800	+71	95%
9	23	0800	1100	Transition	
9	23	1100	1600	-54	
9	23	1600	1900	Transition	
9-10	23-24	1900	0800	+71	95%
10	24	0800	1100	Transition	
10	24	1100	1600	-54	
10	24	1600	1900	Transition	
10-11	24-25	1900	0800	+71	95%
11	25	0800	1100	Transition	
11	25	1100	1600	-54	
11	25	1600	1900	Transition	
11-12	25-26	1900	0800	+71	
12	26	0800	1100	Transition	
12	26	1100	1600	-54	
12	26	1600	1900	Transition	
12-15	26-29	1900	0800	+71	95%

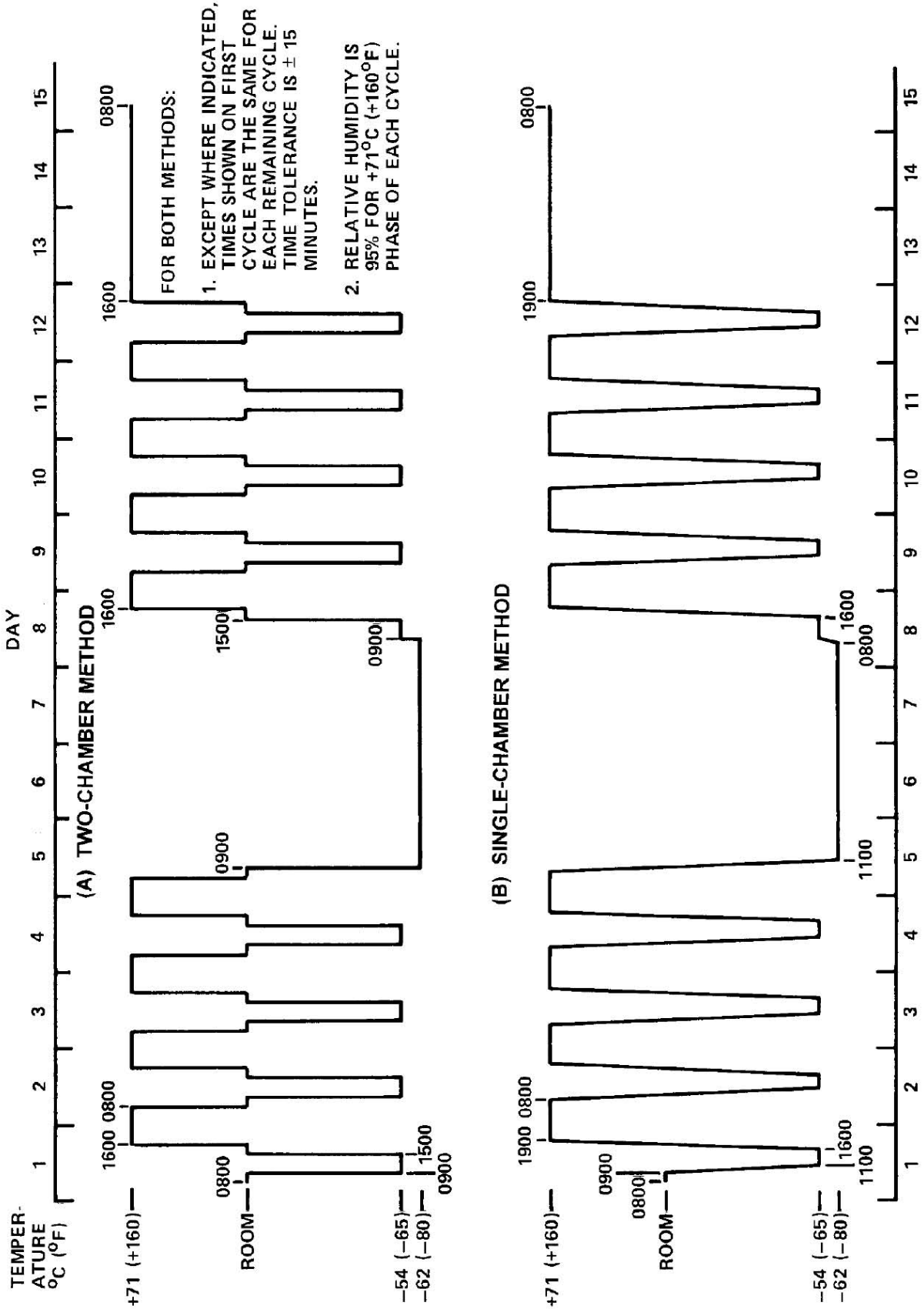

Figure C1-1 Temperature and Humidity Cycle

TEST C2

VACUUM-STEAM-PRESSURE

C2.1 PURPOSE

This is a laboratory safety and reliability test simulating storage or ready use conditions. The fuze must withstand exposure to a series of fifteen-minute vacuum-steam-pressure cycles.

C2.2 DESCRIPTION

C2.2.1 General. Experience has shown that fuzes which survive this test are likely to survive at least six months of tropical exposure. It evaluates the effects of these conditions on fuzes with non-breathing seals. Bare fuzes are subjected to 1000 consecutive fifteen-minute cycles in a vacuum-steam-pressure environment. The 1000 cycles take about 10 days of continuous running time. The basic cycle consists of temperature-humidity cycling superimposed on pressure cycling in a test chamber with a salt-laden atmosphere. Representative curves of temperature and pressure versus time are shown in Figure C2-1. This test is designed to accelerate the aging and failure-mode processes of bare fuzes by (1) using increased levels of pressure and vacuum beyond those encountered in normal service use, and (2) decreasing the time elements by using an environmental cycle of fifteen minutes, continuous to a total of 1000 cycles. This accelerated test achieves the same end-failure-modes (for certain types of sealed fuzes) which are experienced in the normal 6 months of tropical storage or ready use conditions.

C2.2.2 Fuze application and configuration. The types of fuzes for which this test is applicable are bonded, non-breathing-seal designs (soldered, welded, brazed, adhesive-sealed) whose case and seal materials have yield strengths beyond the stress levels exerted by the vacuum-pressure test range. All fuze explosive elements shall be present in the fuze during testing.

C2.2.3 Applicable publications. All standards, specifications, drawings, procedures and manuals which form a part of this test are listed in Section 2 of the introduction to this standard. Special attention is directed to NAVSEA OD 7547.

C2.2.4 Test documentation. Test plans, performance records, equipment, conditions, results, and analysis shall be documented in accordance with 4.8 of the general requirements to this standard.

C2.3 CRITERIA FOR PASSING TEST

C2.3.1 Fuze condition. At the completion of this test, the fuze shall be safe for transportation, storage, handling and use, as well as operable in accordance with 4.6.2.1a and 4.6.2.2 of the general requirements to this standard.

C2.3.2 Decision basis. Breakdown, inspection, other appropriate tests and engineering judgment shall form the basis for the decision that fuzes have passed or failed the test.

C2.4 EQUIPMENT

The equipment consists of an insulated chamber with a hinged door for accessibility. The chamber has a circulation fan and is fitted with the necessary piping and valves to control the flow of air, steam, and salt solution. Also included are shelves or baskets to hold the test items and the necessary electronics and monitoring equipment to automatically control the system. Refer to NAVSEA OD 7547.

C2.5. PROCEDURE

C2.5.1 Equipment check. Determine that the equipment is in proper operating condition.

C2.5.2 Testing. Place the items in the chamber and subject them to 1000 ± 10 continuous cycles of 15 ± 1 minutes per cycle as described in 5.2.1 thru 5.2.4, below.

C2.5.2.1 Chamber evacuation. Evacuate the chamber from atmospheric pressure to 700 ± 50 mm Hg (28 ± 2 in Hg) below atmospheric pressure. Evacuation of the chamber shall be accomplished within six minutes.

C2.5.2.2 Steam application. Admit steam into the chamber until the chamber reaches a predetermined temperature. Then pressurize the chamber with air to 0.172 ± 0.013 MPa (25 ± 2 psig), thus obtaining a final temperature of $+66 \pm 1.7^\circ\text{C}$ ($+151 \pm 3^\circ\text{F}$). During the admission of air, 40 ± 2 grams (1.41 ± 0.07 oz) of sodium chloride dissolved in one to 57 liters (one quart to 15 gallons) of distilled water shall be dispersed in the chamber at a uniform rate over 1000 ± 10 cycles. NOTE: The predetermined temperature at which steam flow is shut off will be a function of the particular chamber design. The major variables which affect the steam shut-off temperature are the effective thermal mass of the chamber, thermal mass of the test item, chamber volume, and rate of heat input. The set point for steam shut-off must be adjusted to give the specified temperature after pressurization.

C2.5.2.3 Pressure maintenance. The chamber pressure is maintained at 0.172 ± 0.013 MPa (25 ± 2 psig) for 4 ± 0.25 minutes.

C2.5.2.4 Venting. Vent the chamber, allow the moisture to drain off, and allow the chamber to return to atmospheric pressure.

C2.5.3 Maintaining the test schedule. The test should be continuous but may be interrupted for a maximum of five days. The test items must be stored at ambient conditions during the interruptions. During startup and after periodic inspection, the system may require a few cycles to stabilize conditions. These cycles should not be included or counted as part of the 1000 cycle test.

C2.5.4 Compliance. Analyze the test results and determine whether or not the test article meets the pass/fail criteria in Section 3. Continue testing the specified number of items.

C2.6. ALTERNATE AND OPTIONAL PROCEDURES

None.

C2.7 RELATED INFORMATION

C2.7.1 Background. This ten day test of 1000 cycles has been found to be the equivalent of at least six months Pacific Fleet life for World War II VT Fuzes. These fuzes were waterproofed externally by using lacquer sealants on exposed components. They also contained metal-cased, solder-sealed components. The test was designed to give, on an accelerated basis, the same end failure-modes as had been experienced by the fuze components at the end of 6 to 8 months of fuze storage (in unsealed packages) or ready use (assembled to weapons, with weapons on ready use status). The test has continued in use since then (approximately 1948) as applicable to externally-sealed fuzes with metal-to-metal, metal-to-glass, or other material-to-material bonds giving either fusion or adhesion conditions. It is very important that this test not be used on fuzes which have other types of sealing (O-ring, metal interlocking, breathing-type, and so forth) or those which have case materials which cannot survive, on a yield strength or fatigue basis, the force-loading conditions which pertain under vacuum-pressure range of the test. To do so is to misuse the test and invite automatic failure of the fuze under the test conditions. The primary function of this accelerated test is to estimate the term capability of fuze and/or component moisture seals of

MIL-STD-331C
w/CHANGE 1
APPENDIX C

the specified type after at least 6 months of tropical storage.

C2.7.2 Revisions. Test 106.1, redesignated Test C2, was written to correct thermodynamic discrepancies in the requirements of Test 106, to clarify the procedure, and to establish tolerances for a more reliable and repeatable test.

Figure C2-1. Typical Test Curves of Pressure and Temperature Versus Time.

MIL-STD-331C
w/CHANGE 1
APPENDIX C

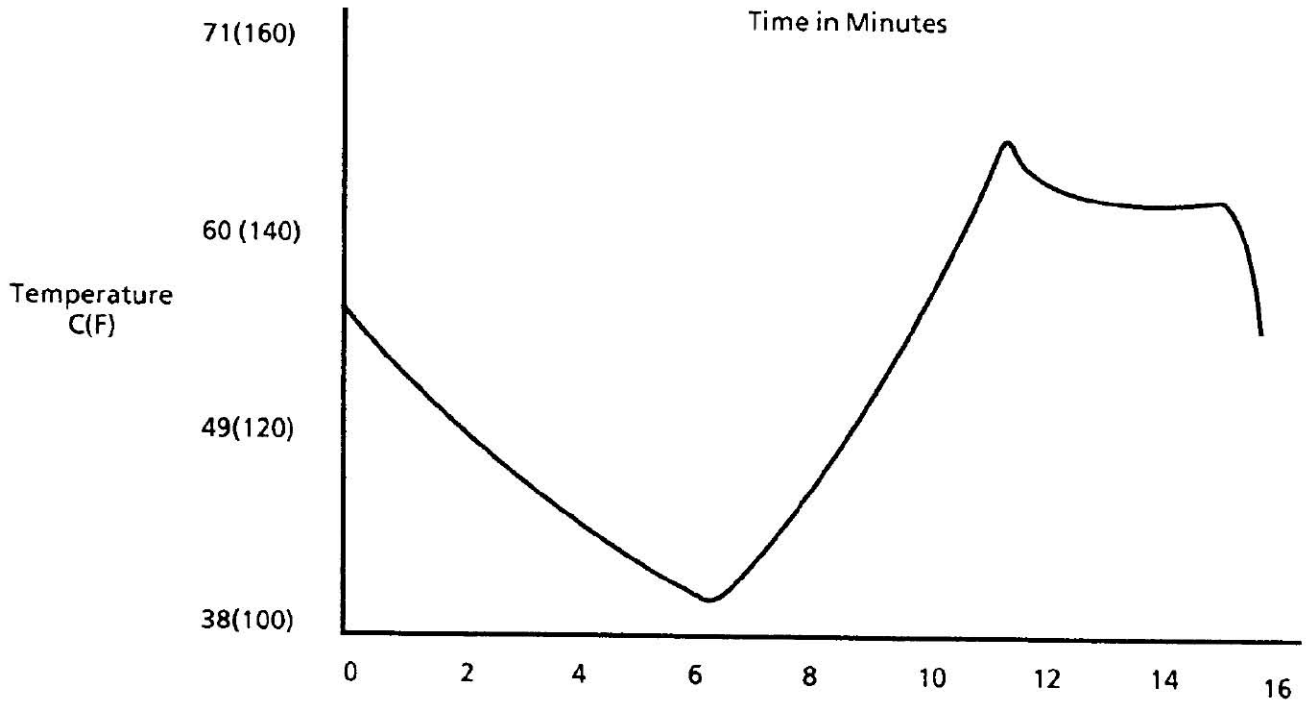
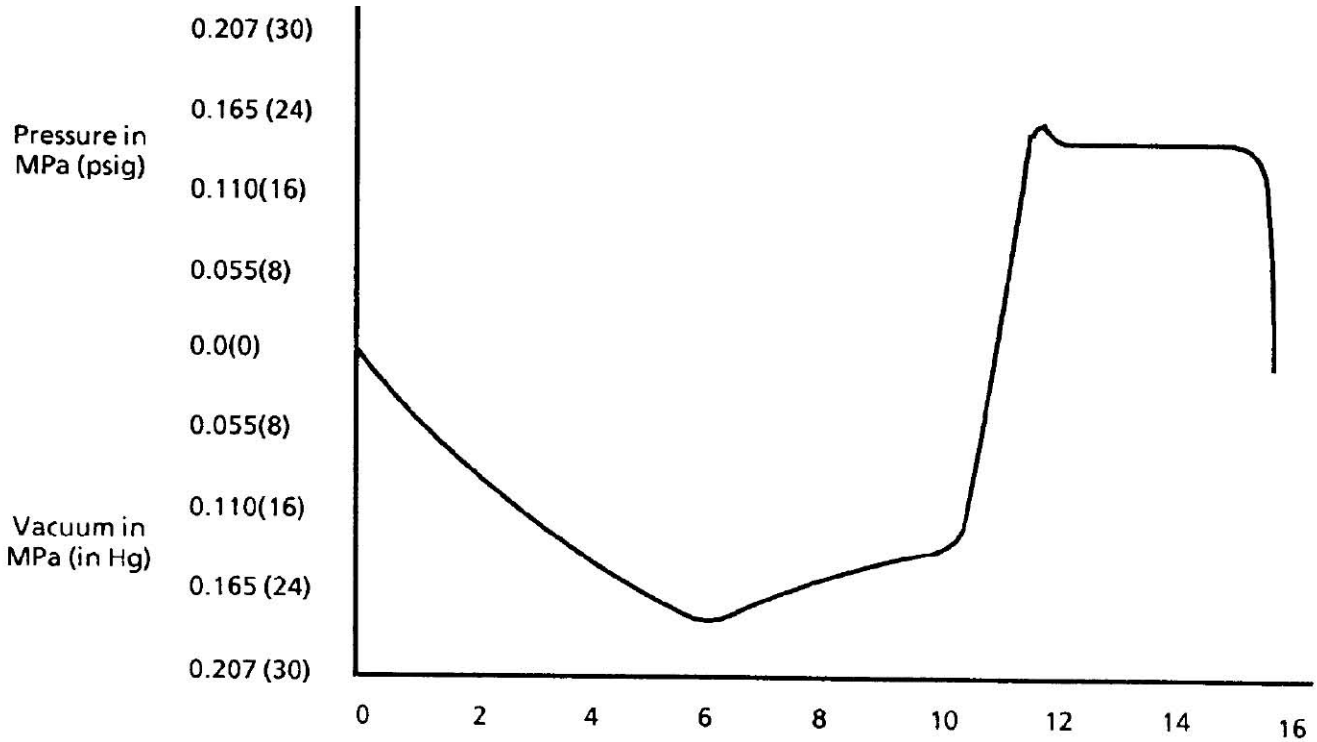

Typical pressure and temperature cycles.
Exact duplication is not required.

Time in Minutes

FIGURE C2-1. Typical Test Curves of Pressure and Temperature Versus Time.

TEST C3

SALT FOG

C3.1 PURPOSE. This is a laboratory safety and reliability test simulating bare fuze exposure to a moist, salty atmosphere.

C3.2 DESCRIPTION

C3.2.1 General. Bare fuzes are exposed to a salt fog atmosphere. The test directive shall specify one of two test durations. Fuzes subjected to the test for 48 hours are checked for safety and operability; fuzes tested for 96 hours are checked for safety only. At least eight fuzes are required for each test. Two fuzes are tested in each of four orientations. One fuze from each orientation is then evaluated immediately after the test while still wet. The remaining four fuzes are first dried and then evaluated.

C3.2.2 Fuze configuration. All fuze explosive elements shall be present in the fuze during the test.

C3.2.3 Applicable publications. All standards, specifications, drawings, procedures and manuals which form a part of this test are listed in Section 2 of the introduction to this standard.

C3.2.4 Test documentation. Test plans, performance records, equipment, conditions, results, and analysis shall be documented in accordance with 4.8 of the general requirements to this standard.

C3.3 CRITERIA FOR PASSING TEST

C3.3.1 Fuze condition. At the completion of a 48-hour test, the fuze shall be safe for transportation, storage, handling and use, as well as operable in accordance with 4.6.2.1a and 4.6.2.2 of the general requirements to this standard. At the completion of a 96-hour test, the fuze shall be safe for transportation, storage, handling and use in accordance with 4.6.2.2a of the general requirements to this standard. In 96-hour tests, the fuze does not have to be operable.

C3.3.2 Decision basis. Breakdown, inspection, other appropriate tests and engineering judgment shall form the basis for the decision that fuzes have passed or failed the test.

C3.4 EQUIPMENT

C3.4.1 General. The equipment shall include an exposure chamber with a salt solution reservoir, sufficient atomizing or spray nozzles, test specimen supports, a chamber heating and temperature control system, a source of compressed air, a pressure regulator, and a compressed air humidifying system.

C3.4.2 Test chamber. The chamber and accessories shall be constructed of materials which do not react with, and are not affected by, the corrosiveness of the salt fog, and do not react with or affect the test specimens. Suitable materials for construction of the chamber are rubber "Alberene Stone", chemical stoneware, plate glass, slate or stainless steel. Suitable materials for the construction or coating of racks and supports are glass, rubber, plastic or suitably coated wood; bare metal (even stainless steel) should not be used. The chamber shall be of adequate size, with respect to the test specimens, to provide circulation about all specimens to the same

MIL-STD-331C
w/CHANGE 1
APPENDIX C

degree. The top of the chamber shall be inclined to prevent dripping of condensed liquid upon the specimens. Provision shall be made to seal the door opening of the chamber against the loss of fog when the chamber is in operation. A drain shall be provided at the low point in the chamber to remove condensed salt fog from the chamber, and also prevent its return to the salt solution reservoir. A vent shall be located in the wall of the chamber as far from the atomizer as practicable. A salt solution reservoir (internal or external) shall be adequately covered to prevent contamination of condensed fog returning to the reservoir. The reservoir should hold at least a 24 hour supply of salt solution.

C3.4.3 Climate control equipment.

C3.4.3.1 Temperature. The air temperature in the chamber shall be controlled between 32°C and 36°C (90°F and 97°F) by heating the wall and floor surfaces. This can be obtained by water jacketing, or the chamber may be placed in a room with the room temperature controlled to maintain a chamber temperature within the previously specified limits. A suitable method of recording temperature is by a continuous recording device, or by a thermometer which can be read from outside the closed cabinet. The recorded temperature must be obtained with the salt fog chamber closed to avoid a false low reading due to wet-bulb effect when the chamber is open.

C3.4.3.2 Air flow. The salt fog shall be produced by blowing humidified air through a nozzle to atomize the salt solution to produce a fine mist. The nozzles shall be located or baffled to prevent direct impingement on test specimens.

C3.4.3.3 Air purity. Compressed air used for the fog nozzles shall be reasonably free from dust, oil, or excessive liquid water particles, and any foreign gases.

C3.4.3.4 Water vapor. The air shall contain sufficient water vapor to be in equilibrium with the atmosphere in the chamber which has at least 84% relative humidity at a temperature of 36°C (95°F). It may be pre-conditioned by passing through a saturator. The size of the air bubbles and the water temperature are the most important controlling factors to condition the air properly. This or any other system may be used provided the compressed air has a relative humidity of 84% to 90% at a temperature of 36°C (95°F) when released inside the chamber. The compressed air should be saturated with water vapor as follows:

Air Pressure [MPa (psig)]	Water Temperature [°C (°F)]
0.082 (12)	43 (110)
0.096 (14)	44 (112)
0.110 (16)	46 (115)
0.124 (18)	47 (117)

C3.5. PROCEDURE

C3.5.1 Test setup. The fuzes shall be placed in the exposure chamber as far away from the fog nozzles as practicable, and in the four positions which are illustrated by Figure C3-1.

C3.5.1.1 Fuze support. Preferably, fuzes shall be supported from the bottom or side. Suspension from glass hooks or waxed string may be used as long as the specified position of the fuzes is obtained. If necessary, a secondary support at the bottom of the fuzes may be used. In all cases, holding devices (supports and suspensions) shall be of inert, non-metallic materials which will not create electrolytic action.

C3.5.1.2 Fuze orientation. Radial orientation of the test fuzes shall be such as to expose

MIL-STD-331C
w/CHANGE 1
APPENDIX C

the most critical or vulnerable parts of the fuzes to the salt fog as determined by engineering judgment or past experience.

C3.5.1.3 Fuze isolation. The fuzes shall not contact each other or any material capable of acting as a wick. Each fuze shall be so placed as to permit free settling of fog on all fuzes being tested. Salt solution shall not be permitted to drip on the test specimens and flow of salt solution from holding devices to the fuzes shall be reduced to a practicable minimum.

C3.5.2 Preparation of salt solution. The salt solution shall be prepared by dissolving 5±1 parts by weight of salt in 95 parts by weight of distilled water or water containing not more than 200 parts per million of total solids. In addition, before the solution is atomized, it shall be free of suspended solids before it is placed in the chamber reservoir. This may be done by filtering, decanting or covering the end of the tube leading from the solution reservoir to the atomizer. Use a double layer of white cloth having a mesh which will permit an adequate flow of solution and which will prevent clogging of the nozzles. The salt used shall be sodium chloride containing, on a dry bases, not more than 0.1 percent of sodium iodide and not more than 0.2 percent of total impurities.

C3.5.2.1 pH. The pH of the solution shall be maintained at 6.5 to 7.2, when measured at a temperature of 32° to 36°C (90° to 97°F). The pH measurement shall be made electrometrically (using a glass electrode with a saturated potassium chloride bridge) or colorimetrically (provided the results obtained compare with the electrometric method). The pH of the salt solution can be adjusted by additions of small quantities of diluted c.p. sodium hydroxide solutions. Bromthymol blue has proved a satisfactory indicator for the colorimetric pH measurement of the salt solution.

C3.5.2.2 Salt concentration. A salt solution having a specific gravity of from 1.025 to 1.037, when measured at a temperature of 33°C to 36°C (92°F to 97°F), will meet the concentration requirement of 5±1 percent by weight. To determine the sodium concentration by measuring the specific gravity, at least two clean fog collectors shall be placed within the exposure zone so that no drops or flow of solution from the test fuzes, or any other source, are collected. The collectors shall be placed in the proximity of the test fuzes, one nearest to any nozzle, and the other farthest from all nozzles. Suitable collecting devices for checking fog concentration are glass funnels with the stems inserted through stoppers into graduated cylinders or crystallizing dishes. The fog shall be such that for each 80 sq cm (12.4 sq in) of horizontal collecting area, there will be collected in each collector from 0.5 to 3.0 cc (0.017 to 0.101 oz) of solution per hour based on the average of a run of at least 16 hours.

C3.5.3 Temperature control. The exposure zone of the salt fog chamber shall be maintained at 35 +1 to -2°C (95 +2 to -3°F) except during those periods when the test is interrupted for exposing, rearranging, or removing test fuzes, or checking or replenishing the solution in the reservoir. The temperature within the exposure zone of the closed cabinet shall be recorded at least twice a day, approximately 7 hours apart.

C3.5.4 Maintenance of the test schedule. The test shall be continuous for the duration of the entire test period. Continuous operation implies that the chamber be closed and the fog operating continuously except for the short daily interruptions necessary to inspect, rearrange, or remove test fuzes, and to check and replenish the solution in the reservoir. Operations shall be so scheduled that these interruptions are held to a maximum of 1 hour (total) in any 48 hour period.

C3.5.5 Evaluation. The fuzes shall be carefully removed from the chamber at the completion of the test with no attempt being made to remove salt deposits. One fuze from each of the four test orientations shall be evaluated after drying, and the other half shall be evaluated while still wet.

C3.5.5.1 Wet fuzes. The wet fuzes shall be evaluated immediately; that is, before the

surface moisture has evaporated.

C3.5.5.2 Drying procedure. The fuzes which are to be dried shall be subjected to circulating air at a temperature of 43°C to 49°C (110°F to 120°F) for a period of 23 to 25 hours, and evaluated as soon as possible thereafter.

C3.5.6 Compliance. Analyze the test results and determine whether or not the test articles meet the pass/fail criteria in Section 3.

C3.6 ALTERNATE AND OPTIONAL TESTS

C3.6.1 Test duration. The test directive shall specify whether the test shall be conducted for 48 or 96 hours. Test results shall be evaluated in accordance with applicable criteria of Section 3.

C3.6.2 Operational tests. The fuzes should be further evaluated at conditions which are considered the most severe for the particular type fuze being tested. For example, mechanical fuzes having rotors, sliders, detents, arming vanes, and so forth, should be subjected to arming tests. In the case of electrical fuzes, circuit breakdown due to leakage of capacitors, and so forth, should be checked while the fuze is wet.

C3.6.3 Low temperature test. This salt fog test is used to determine the resistance of fuzes to a moist, salt-laden atmosphere. It is an accelerated test that cannot necessarily be correlated to marine or service conditions. For some applications, the fuze should be subjected to low temperature tests immediately following the salt fog test. In this case, the fuze should be exposed to the low temperatures while it is still wet.

C3.7 RELATED INFORMATION

C3.7.1 Test effects. The following damage or malfunctions may result from this test:

- a. Rust or corrosion of metals,
- b. Binding or non-operation of moving parts due to salt deposits,
- c. Obscuring of windows or markings due to salt deposits,
- d. Surface electrical leakage,
- e. Electrical arcing,
- f. Short circuiting of electrical components,
- g. Development of potential breakage lines in metals and plastics, and
- h. Electrochemical decomposition in areas having dissimilar materials in close proximity.

C3.7.2 Limitations of test. In using this salt fog test, it should be recognized:

- a. Withstanding this test does not guarantee that the fuzes will survive other corrosive, marine or service environments.
- b. Failing this test does not necessarily mean that the fuzes would fail other corrosive, marine or service environments.
- c. Although this test may prove useful for comparing the corrosion resistance of materials and coating under accelerated conditions, it is generally unreliable for predicting their comparative service life.
- d. The salt fog test is generally acceptable for evaluating the uniformity (that is, thickness and degree of porosity) of protective coatings, metallic and non-metallic, of different lots or the same product once some standard level of performance has been established. (When used to check the porosity of metallic coatings, the test is more dependable when applied to coatings which are cathodic rather than anodic in reference to the base metal.)
- e. The test can also be used to detect the presence of free iron contaminating the surface of another metal by inspection of the corrosion products.

C3.7.3 Bibliography.

C3.7.3.1 Memorandum Report M60-22-1, *Standardization of Salt Spray Testing Chambers and Techniques*, Frankford Arsenal, February 1960.

C3.7.3.2 Final Report No. NADC-EL-59101, *Investigation and Development of a Salt Spray Test Procedure*, U.S. Naval Air Development Center, 6 January 1960.

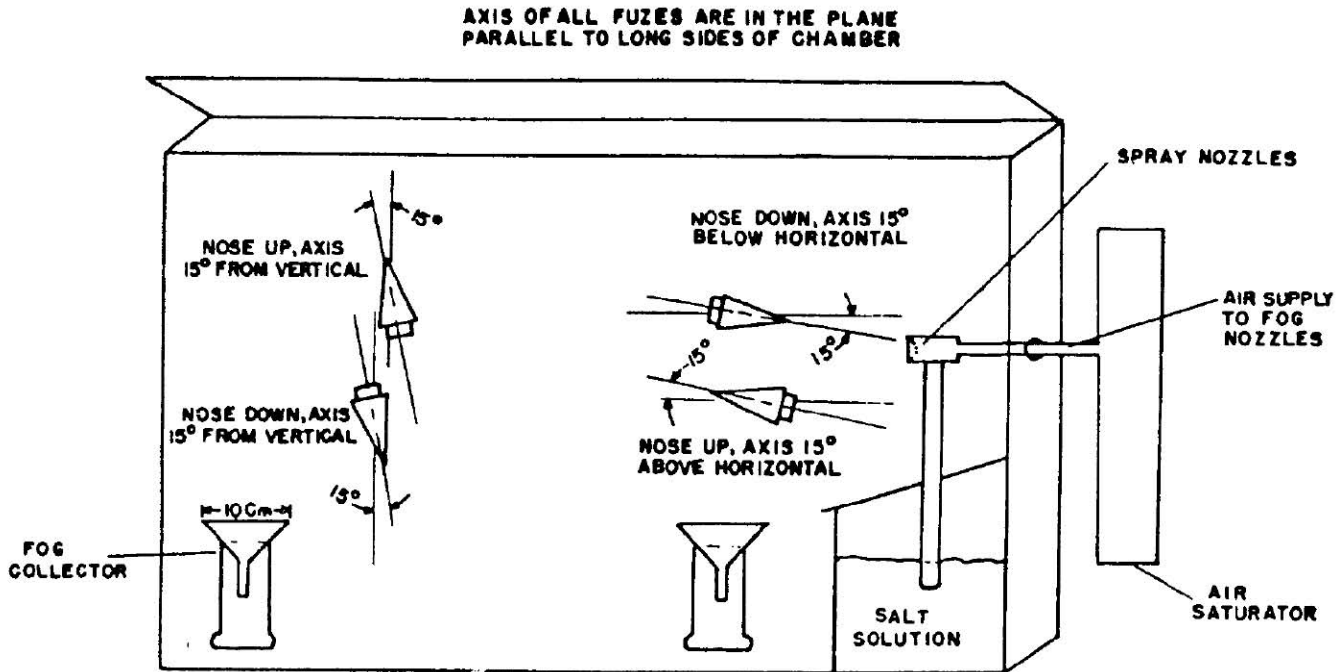

FIGURE C3-1. Salt Fog Test Setup

TEST C4

WATERPROOFNESS

C4.1. PURPOSE

This is a laboratory safety and reliability test which subjects the fuze to submersion in water. The fuze must remain free of leaks when submerged to a depth of 10.7 m (35 ft) of water.

C4.2. DESCRIPTION

C4.2.1 General. This test consists of subjecting bare fuzes to immersion for one hour in a water solution of sodium fluoresceinate (uranin) under a pressure of approximately one atmosphere (0.100 MPa (15 psig) at 21°C (70°F)), and subsequently examining the disassembled fuzes for evidence of water entry.

C4.2.2 Fuze configuration. When specified by the design agency, all fuze explosive elements shall be present in the fuze during the test.

C4.2.3 Applicable publications. All standards, specifications, drawings, procedures and manuals which form a part of this test are listed in Section 2 of the introduction to this standard.

C4.2.4 Test documentation. Test plans, performance records, equipment, conditions, results, and analysis shall be documented in accordance with 4.8 of the general requirements to this standard.

C4.3. CRITERIA FOR PASSING TEST

C4.3.1 Fuze condition. There shall be no evidence that any water has entered the fuze. At the completion of this test, the fuze shall be safe for transportation, storage, handling and use, as well as operable in accordance with 4.6.2.1a and 4.6.2.2 of the general requirements to this standard.

C4.3.2 Decision basis. Breakdown, inspection, other appropriate tests and engineering judgment shall form the basis for the decision that fuzes have passed or failed the test.

C4.4. EQUIPMENT

C4.4.1 Pressure vessel. The equipment required to conduct this test includes a pressure vessel capable of withstanding the applied pressure safely, and of sufficient size to accommodate enough water to completely cover all types of fuzes to be tested.

C4.4.2 Fixtures. If fixtures are used in the vessel to hold the fuzes in particular orientations, the design of the fixtures shall be such that entrance of the water solution into the fuzes will not be impeded, and that the fuzes will be completely submerged.

C4.4.3 Pressurized air or water. A source of pressurized air, water, or similar medium connected to the pressure vessel and controlled to raise the pressure at the fuzes to 0.100±0.007 MPa (15±1 psig) is required.

C4.4.4 Instrumentation. Suitable instrumentation, such as a pressure gauge or manometer, shall be connected to the vessel to indicate the pressure acting on the fuzes. A temperature indicator shall be provided.

C4.4.5 Water solution. A water solution of 0.2±0.1 percent sodium fluoresceinate (uranin) by weight is required.

C4.4.6 Ultraviolet light. An ultraviolet light is required to examine the disassembled fuze.

C4.5. PROCEDURE

C4.5.1 Temperature. The temperature of the fuzes and water solution shall be stabilized at $21\pm 6^{\circ}\text{C}$ ($70\pm 10^{\circ}\text{F}$) prior to the start of this test and maintained within this temperature range throughout the test. Place the bare fuzes and water solution in the vessel so that the fuzes are completely surrounded by, and in intimate contact with, the water solution. To aid in the elimination of entrapped air, fixtures may be used.

C4.5.2 Pressure. Increase the pressure inside the vessel until the pressure at the fuzes is 0.100 ± 0.007 MPa (15 ± 1 psig). Maintain this pressure for 60 ± 5 minutes.

C4.5.3 Pressure release. At the end of the immersion period, release the pressure within the vessel and remove the fuzes. Wash the exterior of the fuzes thoroughly in clear running water for about two minutes. Then dry the fuzes with a clean dry cloth.

C4.5.4 Compliance. Disassemble each fuze and inspect the components. Analyze the test results and determine whether or not the test article meets the pass/fail criteria in C4.3. Continue testing the specified number of items.

C4.6. ALTERNATE OR OPTIONAL TESTS

None.

C4.7. RELATED INFORMATION

C4.7.1 Application. This waterproofness test is effective in determining whether the design of the fuze is adequate to withstand conditions of submersion which might be encountered, for instance, in a flooded magazine or a beach operation.

C4.7.2 Use of ultraviolet light. The characteristic color of a wet fluorescein stain under ultraviolet light is a bright yellow. Care must be exercised not to confuse this stain with many oils which also appear yellow under ultraviolet light. Most metals have a bluish cast under ultraviolet light. Plastic materials under ultraviolet light vary in color but have little or no tendency to appear yellow. Examination of the disassembled fuze under ultraviolet light is improved when other light is excluded. The salt stain is persistent but must be moist when examined. If the components have dried, a water atomizer may be used to moisten salt deposits which may be present.

TEST C5

FUNGUS

C5.1. PURPOSE

This is a laboratory safety and reliability test simulating adverse storage conditions. The fuze must withstand the effects of fungus growth.

C5.2. DESCRIPTION

C5.2.1 General. Bare fuzes are inoculated with fungi and exposed for a 28-day incubation period to conditions of temperature and humidity conducive to the growth of fungi.

C5.2.2 Test fuzes. All explosive elements shall be present in the fuze during the test.

C5.2.3 Applicable publications. All standards, specifications, drawings, procedures and manuals which form a part of this test are listed in Section 2 of the introduction to this standard. Special attention is directed to ASTM-G21 and ASTM-G22 which have specific applications.

C5.2.4 Test documentation. Test plans, performance records, equipment, conditions, results and analysis shall be documented in accordance with Section 4.8 of the general requirements to this standard.

C5.3. CRITERIA FOR PASSING TEST

C5.3.1 Fuze condition. At the completion of this test, the fuze shall be safe for transportation, storage, handling and use, as well as operable in accordance with 4.6.2.1a and 4.6.2.2 of the general requirements to this standard.

C5.3.2 Appearance. The appearance of fungi on the fuze may not be cause for rejection, unless the growth or utilization of substrate (fungal deterioration of fuze materials) interferes with the safety and operability of the fuze. In this respect, this test differs from fungus tests designed to evaluate the fungus resistance properties of materials. The magnitude of the fungus growth may be less important than the effect of the growth on fuze function. This statement does not contradict the requirement of C5.5.6.2, which calls for an abundant growth on the control item, since the objective there is to insure that the fungus is viable and that the chamber conditions are conducive to fungal growth.

C5.3.3 Decision basis. Breakdown, inspection, other appropriate tests and engineering judgment shall form the basis for the decision that fuzes have passed or failed the test.

C5.4. EQUIPMENT

C5.4.1 Test chamber. The equipment required to conduct this test consists of chambers or cabinets in addition to auxiliary instrumentation capable of establishing and maintaining the specified conditions of temperature and humidity. Provisions must be made in the design of the test chamber to prevent condensation from dripping on the fuzes.

C5.4.2 Chamber environment. The interior of the chamber and fixtures which hold the fuzes shall be made of materials inert to high humidity and fungal attack (for example, stainless steel). The design of the fixture shall be such to allow free circulation of air around the fuzes, and the surface area of the fixtures in contact with the fuzes shall be kept to a minimum. When forced air is employed, the flow should not exceed one meter per second (3.3 ft/s) over the surface of the test fuzes.

C5.5. PROCEDURE

C5.5.1 Preparation of mineral-salts solution. The solution shall contain the following:

Potassium dihydrogen orthophosphate (KH ₂ PO ₄)	0.7 g
Potassium monohydrogen orthophosphate (K ₂ HPO ₄)	0.7 g
Magnesium sulfate heptahydrate[MgSO ₄ (H ₂ O) ₇]	0.7 g
Ammonium nitrate (NH ₄ NO ₃)	1.0 g
Sodium chloride (NaCl)	0.005 g
Ferrous sulfate heptahydrate[FeSO ₄ (H ₂ O) ₇]	0.002 g
Zinc sulfate heptahydrate [ZnSO ₄ (H ₂ O) ₇]	0.002 g
Manganous sulfate monohydrate [MnSO ₄ (H ₂ O)]	0.001 g
Distilled water	1000 ml

Sterilize the mineral salts solution by autoclaving at 121°C (250°F) for 20 minutes. Adjust the pH of the solution by the addition of 0.01 normal solution of NaOH so that after sterilization, the pH is between 6.0 and 6.5. Prepare sufficient salts solution for the required tests.

C5.5.1.1 Purity of reagents. Reagent grade chemicals shall be used in all tests. Unless otherwise specified, it is intended that all reagents shall conform to the specification of the Committee on Analytical Reagents of the American Chemical Society, where such specifications are available.

C5.5.1.2 Purity of water. Unless otherwise specified, reference to water shall be understood to mean distilled water or water of equal purity.

C5.5.2 Preparation of mixed spore suspension. The following test fungi shall be used:

Fungi	ATCC No. *	QM No. **
<i>Aspergillus niger</i>	9642	386
<i>Aspergillus flavus</i>	9643	380
<i>Aspergillus versicolor</i>	11730	432
<i>Penicillium funiculosum</i>	11797	474
<i>Chaetomium globosum</i>	6205	459

* American Type Culture Collection, 12301 Parklawn Drive, Rockville, Maryland 20852.

** U.S. Dept. of Agriculture (SEA/FR), Northern Region Research Center, ARS Culture Collection, 1815 North University St. Peoria, IL 60604.

MIL-STD-331C
w/CHANGE 1
APPENDIX C

Maintain cultures of these fungi separately on an appropriate medium such as a potato dextrose agar. However, the culture of chaetomium globosum shall be cultured on strips of filter paper on the surface of mineral salts agar. (Mineral salts agar is identical to mineral salts solution described in 5.1, but contains, in addition, 15.0g of agar per liter.) The stock cultures may be kept for not more than 4 months at $6\pm 4^{\circ}\text{C}$ ($43\pm 7^{\circ}\text{F}$) at which time subcultures shall be made and new stocks shall be selected from the subcultures. If genetic or physiological changes occur, obtain new cultures as specified above. Subcultures used for preparing new stock cultures, or the spore suspension, shall be incubated at 30°C (86°F) for 7 to 10 days. Prepare a spore suspension of each of the five fungi by pouring into one subculture of each fungus, a 10-ml portion of a sterile solution containing 0.05g per liter of a non-toxic wetting agent, such as sodium dioctyl sulfosuccinate or sodium lauryl sulfate. Use a sterile platinum or nichrome inoculating needle to gently scrape the surface growth from the culture of the test organism. Pour the spore charge into a sterile 125 ml glass-stoppered Erlenmeyer flask containing 45 ml of sterile water and 50 to 75 solid glass beads, 5mm in diameter. Shake the flask vigorously to liberate the spores from the fruiting bodies, and to break the spore clumps. Filter the dispersed fungal spore suspension, through a 6mm layer of glass wool contained in a glass funnel, into a sterile flask. This process should remove mycelial fragments. Centrifuge the filtered spore suspension aseptically, and discard the supernatant liquid. Resuspend the residue in 50 ml of sterile water and centrifuge. Wash the spores obtained from each of the fungi in this manner 3 times. Dilute the final washed residue with sterile mineral-salts solution in such a manner that the resultant spore suspension shall contain $1,000,000\pm 200,000$ spores per ml as determined with a counting chamber. Repeat this operation for each organism used in the test, and blend equal volumes of the resultant spore suspension to obtain the final mixed spore suspension. The spore suspension may be prepared fresh each day or may be held at $6\pm 4^{\circ}\text{C}$ ($43\pm 7^{\circ}\text{F}$) for no more than 4 days.

C5.5.3 Viability of inoculum control. With each daily group of tests, place each of 3 pieces of sterilized filter paper, 1 inch square, on hardened mineral salts agar in separate Petri dishes. Inoculate these with the spore suspension by spraying the suspension from a sterilized atomizer (De Vilbiss No. 154 atomizer has been found satisfactory) until initiation of droplet coalescence. Incubate these at 30°C (86°F) at a relative humidity not less than 85 percent, and examine them after 7 days of incubation. There shall be copious growth on all 3 of the filter paper control specimens. Absence of such growth shall require repetition of the test.

C5.5.4 Control items. In addition to the viability of inoculum control, known susceptible substrates shall be inoculated along with the test item to insure that proper conditions are present in the incubation chamber to promote fungi growth. The control items shall consist of 234 g (8.25 ounce) cotton duck strips that are 32 mm (1.25 in) wide, that have been dipped into a solution containing 10 percent glycerol, 0.1 percent potassium dihydrogen orthophosphate (KH_2PO_4), 0.1 percent ammonium nitrate (NH_4NO_3), 0.025 percent magnesium sulfate [$\text{MgSO}_4(\text{H}_2\text{O})_7$], and 0.05 percent yeast extract (pH 5.3), and from which the excess liquid has been removed. The strips should be hung to air dry before being inoculated and placed into the chamber.

C5.5.5 Inoculation of test and control items.

C5.5.5.1 Mounting. Mount the test and control items on suitable fixtures or suspended from hangers.

C5.5.5.2 Chamber preconditioning. Precondition the chamber and its contents at: 30°C (86°F) and $97\pm 2/-0\%$ relative humidity for at least 4 hours.

C5.5.5.3 Inoculation. Inoculate the test and control items with the mixed fungus spore suspension (5.2) by spraying it on the test and control items in the form of a fine mist from a

MIL-STD-331C
w/CHANGE 1
APPENDIX C

previously sterilized atomizer or nebulizer. In spraying the test and control items, care should be taken to cover all surfaces. If the surfaces are non-wetting, spray until initiation of droplet coalescence. Incubation is to be started immediately following the inoculation.

C5.5.6 Incubation.

C5.5.6.1 Chamber environment. Maintain the test chamber at 30°C (86°F) and 97 + 2 percent relative humidity for the duration of the test. Keep the test chamber closed during the incubation period, except during inspection, or for addition of other test items.

C5.5.6.2 7th day inspection. After 7 days, inspect the growth on the control items to be assured that the environmental conditions are suitable for growth. If inspection reveals that the environmental conditions are not suitable for growth, the entire test must be repeated. If the control items show satisfactory fungal growth, continue the test for a period of 28 days from the time of inoculation.

C5.5.7 Final inspection. After completion of the 28 day incubation period, half of the test fuzes shall be removed from the test chamber and checked as soon as practicable for compliance with 3.1. The remaining half of the fuzes shall be stored for 24 hours at 24±6°C (75.2±10.8°F), and a maximum relative humidity of 40%, after which the fuzes shall be checked as soon as practicable for compliance with C5.3.1. In the case of hermetically sealed fuzes, they shall be opened and the interior examined for evidence of fungus growth or damage.

NOTE: Conductive solutions used as a spore media and growth accelerator may affect operational tests.

C5.5.8 Compliance. Analyze the test results and determine whether or not the test article meets the pass/fail criteria in Section C5.3. Continue testing the specified number of items.

C5.6. ALTERNATE AND OPTIONAL TESTS

Other fungi. The successful completion of this test does not necessarily insure that the item will not be affected by other strains of fungi. The number of strains is too great for inclusion of all fungi, either individually or by groups, in a test such as this one. Therefore, engineering judgment must be relied upon in the application of this test and the decision of whether more extensive testing is required.

C5.7. RELATED INFORMATION

C5.7.1 Effects of fungus. Fungus frequently causes malfunctions of electrical items due to open or short circuits, depending upon the humidity of the surrounding air. These conditions are a result of the chemical action of fungal secretions on metal parts forming salts which may hold relay points open if dry, and shorting the points if humid. Shorts are often caused by "living bridges" of fungi directly between contacts, wires or to ground which can result in a "hot" chassis. On mechanical fuzes, this accumulation of salts and fungal growth could prevent the detonator rotor from moving to the "in line" position. Also, the fungi produce compounds, such as acids, during metabolism which can cause corrosion, glass etching, changes in grease, and other physical and chemical reactions.

C5.7.2 Test Background. The fungus test was revised primarily to require the use of more typical and stable fungi as determined by the U.S. Army Natick Laboratories. This revision includes refined technique definitions, an additional purpose that the test is not performed under field conditions, but under conditions conducive to fungus growth, and incorporates accept/reject criteria.

C5.7.3 Bibliography.

Cyclopedia of Chemistry, Clark and Hawley, "Fungi", pp. 428-429.

TEST C6

EXTREME TEMPERATURE

C6.1. PURPOSE

This is a laboratory safety and reliability test simulating storage conditions. The fuze must withstand continuous exposure to extreme low and high temperatures.

C6.2. DESCRIPTION

C6.2.1 General. Enclosed chambers are used to subject fuzes to extreme low and high temperatures for specified periods. The extreme temperature exposure procedure provides three options, one of which (C6.2.1.1, C6.2.1.2 or C6.2.1.3) must be specified in the test directive.

C6.2.1.1 Extreme low and high temperature exposure. The bare, unpackaged fuzes are conditioned at -54°C (-65°F) for 28 days followed by exposure at +71°C (+160°F) for an additional 28 days.

C6.2.1.2 Extreme low temperature exposure. The bare, unpackaged fuzes are conditioned at -54°C (-65°F) for 28 days.

C6.2.1.3 Extreme high temperature exposure. The bare, unpackaged fuzes are conditioned at +71°C (+160°F) for 28 days.

C6.2.2 Fuze configuration. The fuzes shall be completely assembled, including all explosive elements which are a part of the fuze design.

C6.2.3 Applicable publications. All standards, specifications, drawings, procedures and manuals which form a part of this test are listed in Section 2 of the introduction to this standard. Special attention is directed to MIL-HDBK-310, NAVSEA OS 6341 and AR 705-15, which have specific applications.

C6.2.4 Test documentation. Test plans, performance records, equipment, conditions, results, and analysis shall be documented in accordance with 4.8 of the general requirements to this standard.

C6.3. CRITERIA FOR PASSING TEST

C6.3.1 Fuze condition. At the completion of this test, the fuze shall be safe for transportation, storage, handling and use, as well as operable in accordance with 4.6.2.1a and 4.6.2.2 of the general requirements to this standard.

C6.3.2 Decision basis. Breakdown, inspection, other appropriate tests and engineering judgment shall form the basis for the decision that fuzes have passed or failed the test.

C6.4. EQUIPMENT

C6.4.1 Chamber. The equipment required to conduct this test consists of chambers designed to control the temperature. Single-purpose chambers which will maintain only one temperature, one type for +71°C (+160°F), and another type for -54°C (-65°F), may be used. More versatile equipment which will provide both temperatures is also satisfactory. The +71°C (+160°F) chamber must maintain a relative humidity of less than 20 percent.

C6.4.2 Fan. Fans must be used to circulate the air in the test chambers. They must be capable of moving air at a rate such that the chamber temperature as measured anywhere, using a

MIL-STD-331C
w/CHANGE 1
APPENDIX C

bare 30-gauge thermocouple or equal, within two inches of the fuzes and the chamber walls, floor, and ceilings, is within 2.2°C (4°F) of the chamber set point within four hours after the fuzes have been placed in the chamber.

C6.4.3 Humidity. There is no requirement for humidity control of the +71°C (+160°F) chamber if the room ambient air, which is heated, is less than +38°C (+100°F) with a relative humidity below 95 percent, and no water is added within the chamber during the test cycle. If these conditions cannot be met, the test chamber must be controlled to insure that the relative humidity is maintained below 20 percent.

C6.4.4 Instrumentation. Continuous records of temperature are required. A sampling type of recording system, such as a multi-point recorder, shall be considered as providing a continuous record if the temperature of the test chamber is measured and recorded not less than once every two minutes. Wet-bulb temperature of the test chamber operating at +71°C (+160°F) does not have to be recorded if the heated room air is below plus +38°C (100°F) with a relative humidity below 95 percent.

C6.4.5 Fuze support. The chamber shall utilize a shelf, rack, grating, or suspension system, composed of material which will not act as a heat conductor to retard or accelerate the temperature change of the test item. The material used to support the fuzes shall have a thermal conductivity equal to or less than 21.3 cal/s/m²/°C/m thickness at a mean temperature of 21.1°C (0.4 BTU)/hour/ft²/°F/inch of thickness at a mean temperature of 70°F). The material in contact with the fuze shall be at least 12.7 mm (1/2 in) thick and shall have a maximum cross sectional area of 645 mm² (1 in²) for each 0.91 kg (2 lb) of weight of the fuze.

C6.5. PROCEDURE

C6.5.1 Precondition. Precondition the fuzes at +21±6°C (+70±10°F) for 12 hours minimum prior to the start of the test.

C6.5.2 Fuze orientation. The fuzes may be placed in any position, but they must be adequately spaced from each other, and from the chamber walls, so that the specified air temperature will be maintained. The test item shall be supported in the chamber on a shelf, rack, grating, or suspension system made of materials which will not act as a heat conductor to retard or accelerate the temperature change of the test item.

C6.5.3 Testing. Perform C6.5.3.1, C6.5.3.2 or C6.5.3.3 as specified by the test directive.

C6.5.3.1 Low and high temperatures.

- a. Place the fuzes in a chamber in operation at -54°C (-65°F).
- b. After 28 days exposure, the fuzes shall be removed from the chamber and placed in a room or conditioning space at +21±6°C (+70±10°F) for one hour, and then transferred to a chamber at +71°C (+160°F) with a relative humidity of less than 20 percent for 28 days.
- c. As an alternate method, the original chamber may be used without moving the fuzes. In this case, the temperature of the chamber shall be raised at the rate of +21±11°C (+70±20°F) per hour until the temperature is +71°C (+160°F). The relative humidity shall be maintained at less than 20 percent when the temperature is +71°C (+160°F). The test at this condition shall continue for 28 days.

C6.5.3.2 Low temperature. Place the fuzes in a chamber in operation at -54°C (-65°F) for 28 days.

C6.5.3.3 High temperature. Place the fuzes in a chamber in operation at +71°C (+160°F), with a relative humidity below 20 percent for 28 days.

C6.5.4 Examination. At the end of the test, the fuzes shall be removed from the temperature chamber and placed in a room or conditioning space at +21±6°C (+70±10°F) for at

least 16 hours and then examined. Analyze the test results and determine whether or not the test article meets the pass/fail criteria in C6.3.

C6.6. ALTERNATE AND OPTIONAL TESTS

None.

C6.7. RELATED INFORMATION

C6.7.1 Low temperature storage. The low temperature employed in this test might be encountered in regions of extreme cold. There is reason to believe that there are changes in molecular orientation in some materials which occur over a long period of time at low temperature. Therefore, such a test is desirable when nonmetallic materials are under investigation.

C6.7.2 High temperature storage. The high temperature employed in this test may be encountered in tropical and some temperate zone areas. The time has been selected on the basis that deterioration, if it occurs, will be more easily detected as a result of the long exposure.

C6.7.3 Reliability. Frequently, a fuze may be "operable" in a strict sense after conditioning. However, changes may have occurred in materials (such as changed molecular structure in some plastics) which might cause failure in subsequent conditionings, or which might be judged to affect the inherent reliability of the fuze. Such changes indicate weaknesses in the design which, although not immediately disabling to the tested fuze, should be carefully examined. Physical tests of the materials involved are useful in estimating the extent of the damage.

C6.7.4 Fuze placement. The spacing between fuzes is important only with respect to maintaining the temperature. Experience indicates that the fuzes should be about 102 mm (4 in) from the walls, floor, and ceiling of the chamber, and the spacing between fuzes should be about one radius or one inch, whichever is smaller. Some chambers will maintain the temperature with a more dense loading, in which case there is no objection.

C6.7.5 Atmosphere pollution. No provision has been made for determining the effects of foreign gases in the atmosphere, such as carbon dioxide in large concentrations, which may result from using dry ice as the refrigerant. Gases released from the fuze may also be a source of contamination of the air. If the fuzes under test are not sealed, special care should be exercised to avoid effects of contaminated air on the fuzes. Special care should be exercised in the selection of test equipment, the cleanliness of the chamber test space, and the ventilation of the chamber atmosphere to avoid pollution.

C6.7.6 Supporting structure. The requirement for supporting the fuzes (4.5) can be met by using a nonmetallic material such as glass, cork, rubber, or plastic in a sheet or panel form at least 12.7 mm (1/2 in) thick. If necessary to reduce the area in contact with the fuzes, grooves or serrations may be cut in the surface of the material. Another method is to use cord to suspend the fuzes. Still another is to construct a grid-type shelf using nonmetallic material. The grids may be any practical shape or size to provide physical support except that the area of contact with the fuzes must be below the specified limit.

C6.7.7 Bibliography.

C6.7.7.1 "Conditioning and Weathering of Adhesives and Plastics," Reinhard, F.W., American Society for Testing Materials, *Special Technical Publications*, No. 132, 1952.

C6.7.7.2 AR 705-15, *Research and Development of Materiel*.

TEST C7

THERMAL SHOCK

C7.1. PURPOSE

This is a laboratory safety and reliability test simulating storage or tactical conditions. The fuze must withstand sudden transitions in extreme low and high temperatures.

C7.2. DESCRIPTION

C7.2.1 General. Enclosed chambers are used to subject fuzes to extreme low and high temperatures for specified periods. Fuzes are subjected to thermal shocks between the temperatures of -54 and +71°C (-65 and +160°F).

C7.2.2 Fuze configuration. The fuzes shall be completely assembled, including all explosive elements which are a part of the fuze design.

C7.2.3 Applicable publications. All standards, specifications, drawings, procedures and manuals which form a part of this test are listed in Section 2 of the introduction to this standard. Special attention is directed to MIL-HDBK-310, NAVSEA OS 6341, and AR 705-15 which have specific applications.

C7.2.4 Test documentation. Test plans, performance records, equipment, conditions, results, and analysis shall be documented in accordance with Section 4.8 of the general requirements to this standard.

C7.3. CRITERIA FOR PASSING TEST

C7.3.1 Fuze condition. At the completion of this test, the fuze shall be safe for transportation, storage, handling and use, as well as operable in accordance with 4.6.2.1a and 4.6.2.2 of the general requirements to this standard.

C7.3.2 Decision basis. Breakdown, inspection, other appropriate tests and engineering judgment shall form the basis for the decision that fuzes have passed or failed the test.

C7.4. EQUIPMENT

C7.4.1 Chamber. The equipment required to conduct this test consists of chambers designed to control the temperature. Single-purpose chambers which will maintain only one temperature, one type for +71°C (+160°F), and another type for -54°C (-65°F), may be used. More versatile equipment which will provide both temperatures is also satisfactory. The +71°C (+160°F) chamber must maintain a relative humidity of less than 20 percent.

C7.4.2 Fan. Fans must be used to circulate the air in the test chambers. They must be capable of moving air at a rate such that the chamber temperature as measured anywhere, using a bare 30-gauge thermocouple or equal, within two inches of the fuzes and the chamber walls, floor, and ceilings, is within 2.2°C (4°F) of the chamber set point within four hours after the fuzes have been placed in the chamber.

C7.4.3 Humidity. There is no requirement for humidity control of the +71°C (+160°F) chamber if the room ambient air, which is heated, is less than +38°C (+100°F) with a relative humidity below 95 percent, and no water is added within the chamber during the test cycle. If these conditions cannot be met, the test chamber must be controlled to insure that the relative

humidity is maintained below 20 percent.

C7.4.4 Instrumentation. Continuous records of temperature are required. A sampling type of recording system, such as a multi-point recorder, shall be considered as providing a continuous record if the temperature of the test chamber is measured and recorded not less than once every two minutes. Wet-bulb temperature of the test chamber operating at +71°C (+160°F) does not have to be recorded if the heated room air is below plus +38°C (100°F) with a relative humidity below 95 percent.

C7.4.5 Fuze support. The chamber shall utilize a shelf, rack, grating, or suspension system, composed of material which will not act as a heat conductor to retard or accelerate the temperature change of the test item. The material used to support the fuzes shall have a thermal conductivity equal to or less than 21.3 cal/s/m²/°C/m thickness at a mean temperature of 21.1°C (0.4 BTU) /hour/ft²/°F/inch of thickness at a mean temperature of 70°F). The material in contact with the fuze shall be at least 12.7 mm (1/2 in) thick and shall have a maximum cross sectional area of 645 mm² (1 in²) for each 0.91 kg (2 lb) of weight of the fuze.

C7.5. PROCEDURE

C7.5.1 Thermal shock test. The fuze will be placed in the chamber preconditioned at -54°C (-65°F). After a minimum of four hours, the fuze is removed and, within one minute, placed in a chamber preconditioned at +71°C (+160°F) and less than 20 percent relative humidity. After a minimum of four hours, the fuze is removed and, within one minute, placed in the chamber preconditioned at -54°C (-65°F). This process is repeated until the fuze has been exposed to the low temperature and the high temperature three times as illustrated in Figure C7-1. In order for this test to be continued during off duty hours, the 4 hour soaking periods may be extended to a maximum of 65 hours at any point in the cycle.

C7.5.2 Examination. At the end of the test, the fuzes shall be removed from the temperature chamber and placed in a room or conditioning space at +21±6°C (+70±10°F) for at least 16 hours and then examined. Analyze the test results and determine whether or not the test article meets the pass/fail criteria in C7.3.

C7.6. ALTERNATE AND OPTIONAL TESTS

None.

C7.7. RELATED INFORMATION

C7.7.1 Thermal shock. The temperatures used in this test are related to those that might be encountered in the natural environment and some induced environments. The rapid rate of change is useful for investigating certain fuze mechanical constructions that are sensitive to temperature gradients; for example, press-fit assemblies having different materials. The duration employed is considered a safe margin for thorough saturation of most fuzes. If the test item is large and contains considerable amounts of plastic potting or other insulating materials, temperature saturation characteristics should be determined prior to the test to determine whether the four-hour test time should be increased to insure that the test fuzes reach temperature equilibrium during the soak periods. Experience indicates that in some component parts, particularly those molded of plastics, that stresses are incurred from the molding operation, and when these parts are subjected to sudden changes in temperature, ruptures may result. There are other instances where these stress conditions are increased because of metal inserts in plastic material which have different coefficients of expansion and contraction.

C7.7.2 Reliability. Frequently, a fuze may be “operable” in a strict sense after conditioning. However, changes may have occurred in materials (such as changed molecular structure in some plastics) which might cause failure in subsequent conditionings, or which might be judged to affect the inherent reliability of the fuze. Such changes indicate weaknesses in the design which, although not immediately disabling to the tested fuze, should be carefully examined. Physical tests of the materials involved are useful in estimating the extent of the damage.

C7.7.3 Fuze placement. The spacing between fuzes is important only with respect to maintaining the temperature. Experience indicates that the fuzes should be about 102 mm (4 in) from the walls, floor, and ceiling of the chamber, and the spacing between fuzes should be about one radius or one inch, whichever is smaller. Some chambers will maintain the temperature with a more dense loading, in which case there is no objection.

C7.7.4 Atmosphere pollution. No provision has been made for determining the effects of foreign gases in the atmosphere, such as carbon dioxide in large concentrations, which may result from using dry ice as the refrigerant. Gases released from the fuze may also be a source of contamination of the air. If the fuzes under test are not sealed, special care should be exercised to avoid effects of contaminated air on the fuzes. Special care should be exercised in the selection of test equipment, the cleanliness of the chamber test space, and the ventilation of the chamber atmosphere to avoid pollution.

C7.7.5 Supporting structure. The requirement for supporting the fuzes (C7.4.5) can be met by using a nonmetallic material such as glass, cork, rubber, or plastic in a sheet or panel form at least 12.7 mm (1/2 in) thick. If necessary to reduce the area in contact with the fuzes, grooves or serrations may be cut in the surface of the material. Another method is to use cord to suspend the fuzes. Still another is to construct a grid-type shelf using nonmetallic material. The grids may be any practical shape or size to provide physical support except that the area of contact with the fuzes must be below the specified limit.

C7.7.6 Bibliography.

Thermal Shock and Fatigue, Office of Ordnance Research, Project No. 1230, Contract DA-01-009-ORD-454, Technical Report No. 1, September 1956.

MIL-STD-331C
w/CHANGE 1
APPENDIX C

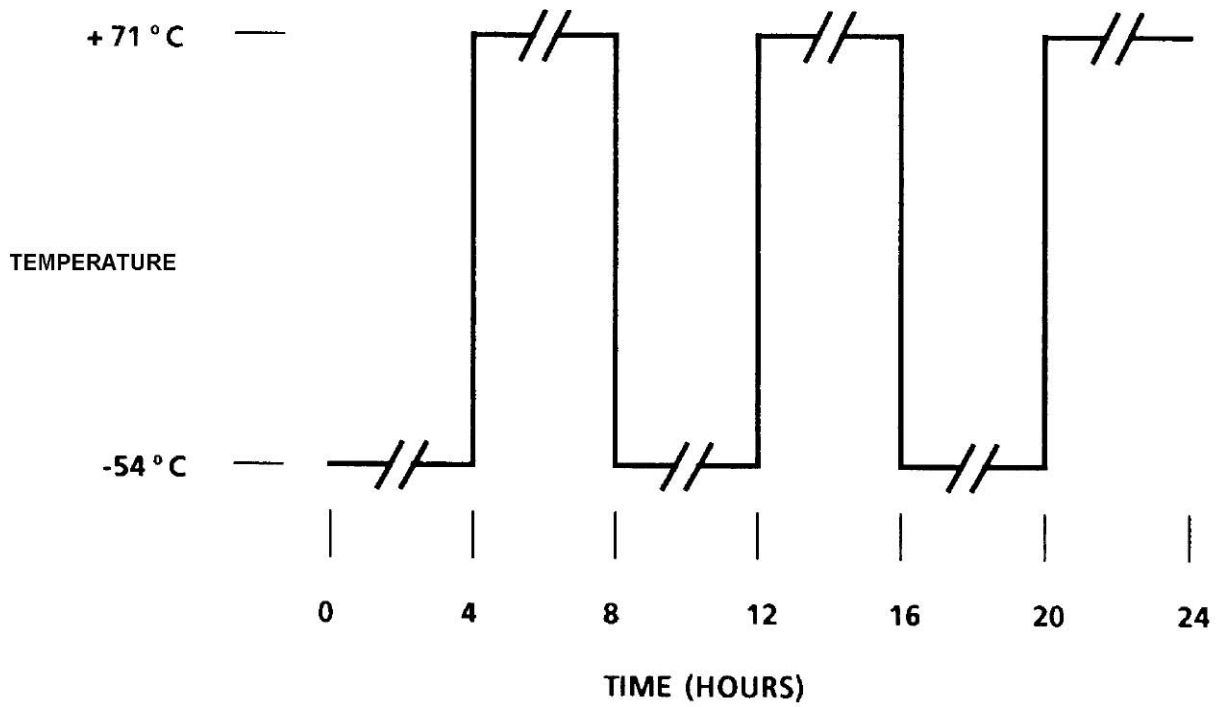

// EXTENSION OF ANY OR ALL 4-HOUR PERIODS UP TO 65 HOURS IS PERMITTED.

FIGURE C7-1. Thermal Shock Cycle

TEST C8

LEAK DETECTION

C8.1. PURPOSE

This is a laboratory performance test to measure the fuze leak rate. Fuzes must exhibit a rate of leakage of a tracer gas or air below the specified limit.

C8.2. DESCRIPTION

C8.2.1 Methods. This test consists of halogen and helium gas methods, each with sub-procedures for determining fine rates of leakage, and the bubble and volume-sharing methods for determining gross rates of leakage of the fuze. The halogen and helium gas methods are used to detect leaks with rates greater than 1×10^{-6} atmosphere cubic centimeters per second (atm cc/s) (fine rates of leakage). The bubble method is used to detect leaks with rates greater than 1×10^{-4} atm cc/s (gross rates of leakage). An optional method for detecting gross leaks, the volume-sharing test, is referred to in Section C8.5.2.2. If no leak rate is specified, the halogen or helium gas method shall be selected.

C8.2.2 Standard leak rate unit. The standard unit of leak rate for this test is the volume per second in cc's of air, at a temperature of 25°C (77°F) and a pressure of one atmosphere. Tracer gas leak rates may have to be converted to standard units of leak rate. While indicated leak rates for halogen gases R-12, R-14, and R-114 are essentially the same as for air, indicated leak rates for helium are 2.7 times as great as for air. More detailed conversion information is given in the references.

C8.2.3 Selection of test method. The selection of a particular leak test method, described in C8.5, is based upon fuze requirements and whether the fuze, at the time of the test, has: 1) a test port usable for tracer gas filling; 2) no test port and is filled with a tracer gas; 3) no test port and is not filled with a tracer gas. When leak rates of 1×10^{-4} atm cc/s or greater are specified in the individual fuze requirements, only a gross leak test need be performed. The gross leak test may be either the bubble method or the optional volume-sharing method.

C8.2.4 Tracer gas-filled fuzes. When testing tracer gas-filled fuzes using fine leak rate methods, a very large leak (gross leak) may yield the same test instrument scale reading as a very small leak, if the leak is sufficiently large to have allowed the tracer gas to escape. Consequently, fuzes that are apparently acceptable as a result of a fine leak test method must be subjected to a gross leak test to establish that the fuze does not exceed the allowable rate. The sequence of gross leak before fine leak test, or fine leak before gross leak test, is based on judgment. In general, the bubble method (gross leak) should follow the halogen or helium methods (fine leak). Surface liquid on the test item during either of the latter tests may affect the test sensitivity. The volume-sharing method of C8.6.1, if used for gross leak, must be closely tailored to the particular fuze configuration and is not detailed herein. The sensitivity of the volume-sharing method must be sufficient to detect leaks equal to or greater than 1×10^{-3} atm cc/s when used as a supplementary gross leak test, or must match the sensitivity required in the individual fuze specification. The volume-sharing method can precede or follow the halogen or helium methods.

C8.2.5 Fuze configuration. During the leak test, the fuzes shall be completely assembled, including all explosive elements that are a part of the fuze design.

C8.2.6 Applicable publications. All standards, specifications, drawings, procedures and

manuals which form a part of this test are listed in C8.2 of the introduction to this standard.

C8.2.7 Test documentation. Test plans, performance records, equipment, conditions, results, and analysis shall be documented in accordance with 4.8 of the general requirements to this standard. The following details should be specified for this test:

- a. Special safety considerations,
- b. Fuze configuration,
- c. Whether gross leak procedure only or fine leak - gross leak procedure is required, and exact method and procedures required,
- d. Fuze orientation for bubble test if critical,
- e. Approximate fuze internal free gas volume and resulting trace gas pressure duration required for C8.5.1.3.1, and
- f. Actual leak test fluid required for bubble method (C8.5.2.1), if critical.

C8.3. CRITERIA FOR PASSING TEST

The fuzes must meet the leak rate requirement established in the individual fuze specification. If no rate has been stated, the leak rate shall not exceed 1×10^{-6} atm cc/s.

C8.4. EQUIPMENT

C8.4.1 Halogen gas method. A halogen leak detector, a halogen leak standard, a halogen gas, necessary valves and fittings, a low-pressure (0.2 MPa) (30 psig) vessel, and a vacuum pump are required. The halogen leak standard is required for calibration of the leak detector before use in the halogen gas test procedures.

C8.4.2 Helium gas method. A mass spectrometer, sensitivity calibrator, helium gas, necessary valves and fittings, a low-pressure (0.2 MPa) (30 psig) vessel, and a vacuum pump are required. The sensitivity calibrator (calibrated leak) is required for calibration of the mass spectrometer before use in the helium gas test procedures.

C8.4.3 Bubble method. A transparent-wall vacuum vessel large enough to hold the test fuze; a system for partially filling the vessel with an appropriate test liquid (for example, water containing a wetting agent) to cover the fuze; vacuum equipment for evacuating the space above the liquid to a pressure of 250 mm of mercury (mm Hg); a gage to indicate the vacuum during the test; and equipment for lowering and raising the fuze into and out of the test liquid. See C8.6.5 for recommendations.

C8.4.4 Safety equipment. Safety features and precautions must be established which consider the possibility of failure of the pressure vessel or a sudden structural failure of the fuze with release of pressure and violent expulsion of fuze parts or inadvertent initiation of explosives which may be in the fuze.

C8.5. PROCEDURE

C8.5.1 Fine Leak Test.

C8.5.1.1 Fuze with test port-filled or not filled. Either the halogen or helium gas method may be used depending on equipment availability or the individual fuze specification. The equipment used must be calibrated with the appropriate leak standard before performing the test.

C8.5.1.1.1 Halogen gas method. If the fuze is or is not filled with a tracer gas, and has a test port or tube leading to the internal cavity, connect the test port or tube to a source of halogen gas. Pressurize the fuze cavity to 0.1 MPa (15 psig) with a halogen gas. Use the probe of the halogen leak detector, with the instrument set on its highest sensitivity scale to inspect all surfaces, joints and seals of the fuze. If leakage is observed, the sensitivity range must be varied until the rate of leakage is determined.

MIL-STD-331C
w/CHANGE 1
APPENDIX C

C8.5.1.1.2 Helium gas method. If the fuze is or is not filled with a tracer gas and has a test port or tube leading to the internal cavity, place the fuze in the vacuum test chamber of the mass spectrometer leak detector. Connect the test port or tube to a vacuum pump and a source of helium. Evacuate the fuze to a pressure of 50 ± 10 mm Hg absolute, and then close the valve to the pump. Pressurize the fuze cavity to 0.1 MPa (15 psig) with helium. Operate the leak detector and observe for leakage.

C8.5.1.2 Fuze with no test port - tracer or gas-filled. Either the halogen or helium gas method may be used depending on equipment availability or the individual fuze specification. The equipment used must be calibrated with the appropriate leak standard before performing the test.

C8.5.1.2.1 Halogen gas method. If the fuze is filled with a halogen tracer gas, the fuze shall be inspected over its surfaces, joints, and seals using the probe of a halogen leak detector. The instrument shall be set on a sensitivity scale to indicate a leak rate of 1×10^{-7} atm cc/s. Unless the concentration of the halogen gas is known, any indication of leakage is unacceptable. A supplementary gross leak test shall be performed if an acceptable leak rate is indicated during this gas test.

C8.5.1.2.2 Helium gas method. If the fuze is filled with helium as a tracer gas, place the fuze in the mass spectrometer leak detector test chamber. Operate the equipment to evacuate the test chamber and observe for leakage. A supplementary gross leak test shall be performed if an acceptable leak rate is indicated during this gas test.

C8.5.1.3 Fuze with no test port - not filled. The mass spectrometer used must be calibrated with the appropriate leak standard before performing the test.

C8.5.1.3.1 Helium gas method. If the fuze is sealed without a trace gas, and neither a test port nor an entrance tube is provided, place the fuze in a pressure vessel. Close the vessel and decrease the pressure to less than 50 mm Hg absolute to remove air from the vessel. No holding time is required. Increase the pressure to 0.100 ± 0.003 MPa (15 ± 0.5 psig) using helium. Maintain the pressure for 4 ± 0.1 hr. Reduce the pressure to atmospheric conditions, open the vessel and remove the fuze. Flush the exterior of the fuze with compressed air. Within 15 minutes after reduction of the pressure from 0.1 MPa (15 psig), place the fuze in the mass spectrometer test chamber and observe for leakage. The internal free gas volume or cavity of the fuze has a direct effect on the attainable sensitivity of this procedure because of the variability of the resulting helium concentration inside the fuze. The duration of pressurization given is for a fuze with an internal free air volume of about one cc (0.06 cu in). The mass spectrometer leak test shall be operated on a scale setting sensitive enough to detect leak rates of 1×10^{-8} atm cc/s. The procedure then will detect a leak rate of approximately 1×10^{-6} atm cc/s. The pressurization duration shall be increased to 12 hours for fuze internal free gas volumes between 1 and 5 cc, and to 24 hours for gas volumes between 5 and 10 cc. Larger internal gas volumes will require longer pressurization durations which may not be practical. See C8.6.3 and C8.7.3 for further information. Any indication of leakage is unacceptable. A supplementary gross leak test shall be performed if an acceptable leak rate is indicated during this test.

C8.5.2 Gross leak test.

C8.5.2.1 Bubble method. Place the fuze in a transparent wall pressure vessel containing a suitable leak test liquid. There should be sufficient test liquid in the vacuum vessel so that when immersed, the fuze will be at least 25.4 mm (1 in) below the liquid level. Place the fuze on the elevating platform in the raised position. Buoyant fuzes shall be secured to the platform. Close the vessel and reduce the pressure in the air space above the liquid surface to a value dependent on the subsequent depth of the test fuze. The air pressure value is chosen so that when the fuze is immersed, the total external pressure on the fuze resulting from the air space pressure, and the

MIL-STD-331C
w/CHANGE 1
APPENDIX C

pressure from the test liquid head is less than prevailing ambient pressure. If the depth of water on the fuze is less than 127 mm (5 in) at its deepest, then a reduction in air pressure of 10 mm Hg (0.39 in Hg) is sufficient. Ten mm of mercury is equal to 137 mm (5.4 in) of water. Then quickly and completely immerse the fuze in the test liquid by lowering the platform. Reduce the pressure of the air space above the liquid to 600 ± 10 mm Hg (23.6 ± 0.39 in Hg) absolute, and hold constant during the observation period of two minutes. A steady stream or recurring succession of small bubbles from the fuze indicates leakage. If large bubbles are observed at any time, the test must be immediately concluded. After the observation period, lift the fuze clear of the test liquid, and then allow the air pressure above the liquid to return to atmospheric. Retrieve the fuze from the vessel, and remove its surface liquid by blowing, blotting, or air drying.

C8.5.2.2 Volume-sharing method. The volume-sharing leak test method may be appropriate for testing fuzes when some question of test liquid compatibility with the fuze makes the bubble method inadvisable. The volume-sharing method consists of surrounding the test fuze with a fixture of a fixed volume and known characteristics. The pertinent characteristics to be established are maximum leak rate of the fixture-volume, and minimum clearance volume around the fuze plus the inside gas volume of the fuze. The pressure in a reservoir of the system is raised or lowered to a fixed value. The closed clearance volume of the fixture around the fuze is then opened to the reservoir of the system. When the pressure in the total system is equalized, it is noted and compared with the value obtained with a non-leaking or dummy fuze. Leakage is indicated when the test pressure is appreciably different. The detail construction of the test equipment too closely depends on the geometry of the fuze to be tested to require the method in this standard. It can, however, be used as an optional method. When so used, the sensitivity of the pressure measuring devices, the sizes of the system volume and clearance volume, and other method details must be chosen so that the method can detect leaks greater than 1×10^{-3} atm cc/s. Reference given in Section C8.7 may help in establishing the test equipment and procedures for a particular fuze.

C8.5.3 Compliance. Analyze the test results and determine whether or not the test article meets the pass/fail criteria in Section C8.3. Continue testing the specified number of items.

C8.6. ALTERNATE AND OPTIONAL TESTS

Several leak tests are contained in other military standards under the title of "seal", "immersion" and so forth. Basic agreement exists between these standards and the test methods of this standard. The differences lie in the test techniques. The test may be conducted at pressures lower than those given above if it is determined that the greater pressures will cause damage to pressure sensitive components or cause seals to become tighter than they ordinarily would be at low temperature differentials. In those cases, it should be determined that the test equipment is capable of giving correct leak rates. If not, proper corrections shall be applied.

C8.7. RELATED INFORMATION

C8.7.1 Purpose. The design purpose in sealing a fuze is to protect the internal parts, mechanisms, circuitry, and so forth, from external contaminants which might affect the fuze's safety and operability during its service life. The logistical portion of the service life may include long periods of storage under a variety of environments, with possible periodic handling for checkout or surveillance, and shipment to and from various depots or service units until assigned to tactical use. During these periods, the protection of the fuze by the fuze packaging may or may not be afforded. The tactical portion of the service life also includes a variety of environments and handling up to and including that of terminal usage. In all of this, the seal which has been devised

as a barrier to protect the internal portions of the fuze against contaminants, must maintain that barrier condition without loss of quality below a chosen level. The actual design method of achieving a seal of the fuze envelope will take many forms, too numerous to discuss in this standard, but all result in a "sealed cavity." Additionally, the resultant sealed cavity may be pressurized to a selected level, usually dependent on the length of service life and external pressure levels expected. The internal pressurization acts as an additional barrier in that it provides an "outflow" of the pressurizing gas through leaks in the seal at laminar or transition flow level (down to 10^{-6} atm cc/s). Any leakage will ultimately result in loss of this internal pressurization and of the "outflow" protection it affords. Steps must be taken to maintain the internal pressurization. Molecular flow is generally considered to occur below the 10^{-6} atm cc/s level; therefore, internal pressurization does not provide an effective additional barrier to leaks in this lower range. Here, the quality of seal becomes the only effective method of protection against in-migration of contaminants. Internal pressurization is usually accomplished using dried air, nitrogen, helium, or a variety of other gasses, all dependent on being chemically inert to the internal materials of the fuze. As in any design effort, a method for testing the design adequacy of the seal under use conditions must then be devised. The test procedures contained herein present some of the more standardized methods of those which are in use. Reference is provided (see C8.7) to some of the more specialized and sophisticated techniques for testing seals. Equipment limitations, test costs and non-standardization limit usage of many of the referenced methods. Those methods required herein utilize the most common approach. "Tracer gases", for which detection equipment has been designed, are included in the pressurizing gas, and are used to "indicate" the presence of leaks in the fuze seal. Also, these methods are supplemented by the well-known bubble method for use when 1) larger leak rates must be investigated, 2) the seal quality level is only required to be measured to that indicative level, or 3) tracer gas methods cannot be used. If the fuze seal cannot be tested using any of the methods required herein, then it is recommended that a usable method from those described in the articles of the bibliography be chosen, or an appropriate method be devised from the principles discussed therein.

C8.7.2 Safety when testing fuzes containing explosive components. In the development of many fuze designs, it may not be necessary to include explosive elements in order to determine the adequacy of the seals. To do so requires additional precautions to meet the hazards involved. Exceptions to C8.2.5 may be made except for tests for final release of the fuze design and production quality assurance provisions.

C8.7.3 Test ports. The mass spectrometer leak detector, using helium as the trace gas, is used in most fuze laboratories. Testing procedures are usually simplified if the fuze has a test port or connecting tube. Thus, designers should be encouraged to include a test port in the fuze design of hermetically-sealed fuzes if a leak test is required. This allows convenient filling of the fuze cavity with a trace gas. Upon completion of the leak test, the test port can be hermetically sealed. For a sealed fuze without a test port, a small leak is difficult to find because saturating the interior with a trace gas is a slow process. For example, if a fuze has a 1 cc cavity and a leak of 1×10^{-6} atm cc/s, it may be tested by the method in C8.5.1.2.2. However, the rate shown on the mass spectrometer will be approximately 1×10^{-8} atm cc/s. See the reference given in Section 7 for a discussion of this effect. When a fuze internal free gas volume is greater than 10 cc, the required pressurization duration becomes impractical, for example, 50 hours for 20 cc (1.2 cu in). For such fuzes, the incorporation of a test port in the fuze design is strongly recommended.

C8.7.4 Bubble test safety. Bubble leak test equipment with all the desirable features is not a standard commercial item. A primary requirement is the safety protection for the operator in case of failure of the vacuum chamber or inadvertent initiation of explosives. Additional safety

shields may have to be added to the commercial equipment used.

C8.7.5 Bubble test equipment. The bubble test method requires equipment for raising and lowering the fuze into and out of the test liquid. A platform must be installed in the chamber above the liquid on which the fuzes may be placed. After the pressure is reduced, the platform and fuzes can be lowered into the liquid. Care must be exercised so that the chamber pressure, plus the head of liquid, will not exceed the gas pressure in the fuze. However, immersion should be accomplished as soon as possible to observe large leaks before all air has been exhausted from the fuze. Upon completion of the observation, the platform is raised above the liquid before the chamber pressure is returned to atmospheric pressure. This procedure will avoid flooding a leaky fuze. The bubble leak test may be a destructive test for some fuzes that have parts external to the sealed envelope that are susceptible to liquid. Also, leaky fuzes may be destroyed by the entry of the liquid if the raising and lowering procedures are not followed or if a very large leak is present. The choice of leak test liquids must be based on engineering judgment and must be specified in the individual fuze specification. Selection of the proper liquid may eliminate the destructive aspects of the test. Suggested leak test liquids are water with a wetting agent added, mineral or silicone oil as used in Method 112, MIL-STD-202, or commercial liquid fluorocarbon ethers.

C8.7.6 Use of waterproofness test. Test C4 (Waterproofness) is a specialized application of leak testing to determine that a fuze will withstand submersion in 10.7 m (35 ft) of water without leaking. Although the procedures of the Leak Detection Test (Test C4) provide a differential pressure on the fuze seals, there may be special applications for which Test C4 is preferred. The engineer responsible for designating the tests should specify the most appropriate test method.

C8.7.7 Halogen gases. Any halogen gas may be used in the halogen method; however, sensitivity of the detector varies with different halogen compounds. For quantitative measurements, proper corrections must be made. Refrigerant R-12 is commonly used because its cost is nominal and its pressure-temperature property is in a convenient range, and it is readily available in many container sizes from one pound up. To avoid false readings, the operator must ventilate the test area to eliminate refrigerant that may have escaped during the filling process or leaked from equipment in the area. Measurements must be made in a clean atmosphere since even cigarette smoke may affect the detector.

C8.7.8 Bibliography.

C8.7.8.1 "Sealed Cavity (Fuze) Leakage Detection and Measurement," Serial No. 37.0, prepared by V. Quail, *The Journal of the JANAF Fuze Committee*. Defense Technical Information Center, Cameron Station, Alexandria, VA 22314.

C8.7.8.2 *Leakage Testing Handbook*, NASA CR-952, by J. William Marr, prepared by General Electric, Schenectady, New York.

C8.7.8.3 "The Back-Pressurizing Technique of Leak-Testing," Howl, D. A. and Mann, C. A., *Vacuum*, Vol. 15, No. 7. Pergamon Press Ltd., UK.

C8.7.8.4 "Practical Application of Leak Detection Methods," by H. McKinny, presented at the 14th Annual Institute of Environmental Sciences Technical Meeting, St. Louis, MO, 29 April - 1 May 1968.

TEST C9

DUST

C9.1. PURPOSE

This is a laboratory safety and reliability test simulating adverse storage, handling, transportation and tactical conditions. The fuze must function properly following exposure to a dusty environment.

C9.2. DESCRIPTION

C9.2.1 General. This test consists of exposing bare fuzes to a turbulent dust atmosphere at specified temperatures and humidity for a period of 12 hours minimum. At least four fuzes are required for the test.

C9.2.2 Fuze configuration. All fuze explosive elements shall be present in the fuze during the test.

C9.2.3 Applicable publications. All standards, specifications, drawings, procedures and manuals which form a part of this test are listed in Section 2 of the introduction to this standard. Special attention is directed to MIL-STD-810 which has/have specific applications.

C9.2.4 Test documentation. Test plans, performance records, equipment, conditions, results, and analysis shall be documented in accordance with 4.8 of the general requirements to this standard.

C9.3. CRITERIA FOR PASSING TEST

C9.3.1 Fuze condition. At the completion of this test, the fuze shall be safe for transportation, storage, handling and use, as well as operable in accordance with 4.6.2.1a and 4.6.2.2 of the general requirements to this standard. Inspection ports must be clear and information labels must be readable after any surface dust is wiped away.

C9.3.2 Decision basis. Breakdown, inspection, other appropriate tests and engineering judgment shall form the basis for the decision that fuzes have passed or failed the test.

C9.4. EQUIPMENT

C9.4.1 Chamber. The equipment required to conduct this test consists of a chamber and accessories to control dust concentration, air velocity, temperature and humidity.

C9.4.2 Free air space. The free air space in the chamber must be sufficient to provide adequate circulation of the dust. Not over 15% of the cross sectional area and 20% of the volume of the chamber should be occupied by the test samples.

C9.4.3 Dust. The dust used in this test shall be of angular structure, shall be at least 97% SiO₂, and shall have the following size distribution as determined by weight, using U.S. Standard Sieve Series:

- a. 100% of the dust shall pass through a 100-mesh screen,
- b. 98±2% of the dust shall pass through a 140-mesh screen,
- c. 90±2% of the dust shall pass through a 200-mesh screen,
- d. 75±2% of the dust shall pass through a 325-mesh screen.

C9.5. PROCEDURE

C9.5.1 Room Temperature Phase.

C9.5.1.1 Mounting. Mount the fuzes as near to the center of the chamber as practicable without having the fuzes contact each other or being shielded from the airborne dust. There should be a minimum of 101.6 mm (4 in) between fuzes, and between fuzes and chamber walls.

C9.5.1.2 Orientation. Orient the fuzes to expose the most critical or vulnerable parts of the fuze to the dust stream.

C9.5.1.3 Exposure. Expose the fuzes to an airborne stream of dust for six hours continuously under the following test conditions:

- a. velocity of air: 533 ± 76 m/min (1750 ± 250 ft/min),
- b. air temperature: $23 \pm 10^\circ\text{C}$ ($73 \pm 18^\circ\text{F}$),
- c. relative humidity not greater than 22%, and
- d. density of dust: $10.6 + 7.1$ mg/l ($0.3 + 0.2$ g/cu ft).

C9.5.2 Transition phase. Stop the dust feed; reduce the air velocity to 91 ± 61 m/min (300 ± 200 ft/min). Raise the internal chamber air temperature to $63 \pm 1.4^\circ\text{C}$ ($145 \pm 2.5^\circ\text{F}$), and adjust humidity control to maintain a relative humidity of less than 10%. Hold these conditions a few hours following temperature stabilization to allow possible penetration. When work schedules permit, the High-Temperature Phase may be conducted upon reaching a stabilized temperature of $63 \pm 1.4^\circ\text{C}$ ($145 \pm 2.5^\circ\text{F}$).

C9.5.3 High-temperature phase. While holding chamber temperature at $63 \pm 1.4^\circ\text{C}$ ($145 \pm 2.5^\circ\text{F}$), expose the fuzes to an airborne stream of dust for six hours continuously under the following test conditions:

- a. velocity of air: 533 ± 76 m/min (1750 ± 250 ft/min),
- b. air temperature: $63 \pm 1.4^\circ\text{C}$ ($145 \pm 2.5^\circ\text{F}$),
- c. relative humidity not greater than 10%, and
- d. density of dust: 10.6 ± 7.1 mg/l (0.3 ± 0.2 g/cu ft).

C9.5.4 Cooling. At the completion of the High Temperature Phase, remove the fuzes from the test chamber and allow them to cool to room temperature.

C9.5.5 Compliance. Analyze the test results and determine whether or not the test article meets the pass/fail criteria in Section C9.3. Continue testing the specified number of items.

C9.6. ALTERNATE AND OPTIONAL TESTS

None

C9.7. RELATED INFORMATION

C9.7.1 Dust as an environment.

Fuzes must be able to withstand the dust environment characteristic of the arid areas of the world without adverse effects on their operating characteristics.

In the field, a fuze may be exposed to the sand and dust environment under conditions ranging from unpacked storage on the ground to being airborne as a component assembled to a missile suspended from the wings of an aircraft.

Dust can be responsible, directly or indirectly, for electrical, mechanical or chemical defects that may result in degraded performance or complete failure.

Some of the types of defects that can result in fuzes from exposure to such an environment are as follows:

- a. Surface electrical leakage,
- b. Inoperative relays,
- c. Electrical arcing in high voltage circuits,

- d. Short circuiting of components,
- e. Changes in oscillator frequency,
- f. Increased mechanical friction or lockup of moving parts, for example, ball bearings, gears and slides,
- g. Development of potential breakage lines in plastic along scratches produced by scouring action of sand,
- h. Obscuring safety or operational information normally visible through transparent windows,
- l. Removal of protective coating by scouring action,
- j. Corrosion by chemical action after removal of the protective coating,
- k. Corrosion of internal components due to water entrapped by dust which penetrates interior of the fuze,
- l. Condensation of moisture on surface and in the interior by small particles acting as nuclei for condensation, and
- m. Scouring away fuze identification or other information imprinted on fuze.

C9.7.2 Background information.

This test is the outgrowth of field and laboratory studies directed at providing a basis for a practical stimulation of a dust environment.

Fine sand samples were procured from many sections of the world. These samples were analyzed for grain size and chemical composition. From these tests, it was determined that foundry sand, of the chemical content and grain size described in C9.4.3, could be used to simulate the effects of blowing dust encountered anywhere in the arid regions of the earth. This foundry sand, high in silica content, is completely non-combustible, and stands relatively high on Moh's scale of hardness. It is 140-mesh silica flour, produced by the Fenton Foundry Supply Co., Dayton, Ohio and Ottawa Silica Co., Ottawa, Illinois.

The overnight low velocity, when used, simulates lightly falling dust. The high velocity represents blowing dust due to high winds, aircraft propellers, and high speed vehicular traffic.

The upper limit of 22% relative humidity corresponds to the highest rh that normally is encountered in an area when dust would be a problem.

Test temperatures of 23°C and 63°C (73°F and 145°F) were chosen to correspond to a nominal ambient and an upper limit that would be experienced in the desert. The 63°C (145°F) is based on an air temperature of 52°C (125°F) plus solar radiation effects, considering the cooling effects of the air velocity.

C9.7.3 Bibliography.

C9.7.3.1 *Physics of Blown Sand in Desert Dunes*, R. A. Bagnold, Dover Publishing Company, 1941.

C9.7.3.2 *Micromeritics - The Technology of Fine Particles*, J. M. Dalla-Valle, Pitman Publishing Company, 1948.

C9.7.3.3 "Air Force Investigates Sand and Dust Testing," *Environmental Quarterly*, 4th Quarter, 1956.

C9.7.3.4 "Sand and Dust Testing," *Environmental Quarterly*, 2nd Quarter, 1957.

TEST C10

SOLAR RADIATION

C10.1 PURPOSE

This is a laboratory safety and reliability test to determine the effects of solar radiation on packaged or unpackaged fuzes or fuzed munitions that may be exposed to sunshine during operation or unsheltered storage.

C10.2 DESCRIPTION

C10.2.1 General. A solar radiation chamber is used to subject fuzes or fuzed munitions to high temperatures and solar radiation for specified periods. The solar radiation exposure procedure provides two options, one of which (C10.2.1.1 or C10.2.1.2) must be specified in the test directive. MIL-STD-810, Method 505 provides expanded discussion/rationale.

C10.2.1.1 Cycling for heat effects. This option is used if the fuze or fuzed munition is expected to withstand the heat from exposure in the open in hot climates and still be able to perform without degradation both during and after exposure. (See C10.7.5.)

C10.2.1.2 Steady state for actinic/photo degradation effects. This option is used if the fuze or fuzed munition is expected to withstand the actinic effects of long periods of exposure to sunshine and still be able to perform without degradation both during and after exposure. (See C10.7.3 and C10.7.6.)

C10.2.2 Fuze/munition configuration. The test item configuration depends on how the fuze or fuzed munition is delivered and used. "Fuze" as used throughout this test shall refer to the fuze or a fuzed munition as applicable.

C10.2.2.1 Unpackaged, fuzed munition. The fuze is assembled to the munition and the assembly is shipped unpackaged, or is unpackaged and subjected to unsheltered storage prior to its use.

C10.2.2.2 Packaged, fuzed munition. The fuze is assembled to the munition and the assembly is shipped in a service package.

C10. 2.2.3 Packaged fuze. The fuze is shipped separately from the munition in the service package.

C10.2.2.4 Bare fuze. The fuze is shipped separately from the munition in the service package, and is removed and subjected to unsheltered storage prior to its usage.

C10.2.3 Explosive components. Warheads are to be inertly loaded. The fuze may contain an inert lead and booster during production acceptance testing, when permitted by the item specification, or when use of a live booster constitutes an excessive hazard.

C10.2.4 Applicable publications. All standards, specifications, drawings, procedures and manuals which form a part of this test are listed in Section 2 of the introduction to this standard. Special attention is directed to MIL-HDBK-310 and Army Regulation 70-38 (see C10.7.6), which give climatic data.

C10.2.5 Test documentation. Test plans, performance records, equipment, conditions, results, and analysis shall be documented in accordance with 4.8 of the general requirements to this standard.

C10.3 CRITERIA FOR PASSING TEST

C10.3.1 Fuze condition. At the completion of this test, the fuze shall be safe for transportation, storage, handling and use, as well as operable in accordance with 4.6.2.1a and 4.6.2.2 of the general requirements to this standard.

C10.3.2 Steady state test. Failure of the steady state test requires further investigation to determine the failure mechanism. If the failure is due to photo degradation effects, the fuze has failed the test; if the failure is due to exaggerated heating effects, the fuze has not failed.

C10.3.3 Decision basis. Breakdown, inspection, other appropriate tests and engineering judgment shall form the basis for the decision that fuzes have passed or failed the test.

C10.4 EQUIPMENT

C10.4.1 Chamber. The equipment required to conduct this test consists of a chamber together with auxiliary instrumentation capable of maintaining and continuously monitoring the required conditions of temperature and solar radiation throughout an envelope of air surrounding the test item. The test chamber and solar radiation sources shall conform to the criteria of MIL-STD-810, Method 505. The floor of the chamber will be covered with light-colored desert sand, or other material that is realistic to produce the severest condition. (See C10.7.7.)

C10.4.2 Temperature control. The term "temperature" used throughout this test is defined unless otherwise specifically stated, as the temperature of the air surrounding the test item. Continuous records of chamber temperature are required. The sensors should be shielded to prevent the direct impingement of radiation and conditioned air. It is essential to control and measure the rate of chamber airflow to preclude the cooling effects of airflow over the test items(s). The air velocity shall be maintained between 0.25 and 1.5 m/s (50 to 300 ft/min). Specific information regarding temperature maintenance and measurement is provided in MILSTD-810, Method 505.

C10.4.3 Instrumentation. Instrumentation shall be installed to measure the following as applicable:

- a. Total irradiance at the test item upper surface or at the level of the most critical location, before and after test.
 - b. Temperature of critical parts or components.
 - c. Air temperature in the vicinity of the test item (sensor protected as in C10.4.2).
- Refer to MIL-STD-810 for more detailed information.

C10.5 PROCEDURE

C10.5.1 Selecting the test options and related conditions. C10.7.4 provides factors to consider with respect to the choice of test option and conditions. Choose the test option, test duration, fuze configuration, and any additional relevant conditions at which to conduct the test.

C10.5.2 Positioning the test items. Place the test item(s) in the chamber at room temperature and in a manner that will simulate service usage, unless the storage configuration is specified in the test directive. As appropriate, the test items shall be positioned in accordance with the following:

- a. As near the center of the test chamber as practical and so that the surface of the test item is no closer than 0.3 m (1 ft) to any wall or 0.76 m (2.5 ft) to the radiation source.
- b. Oriented to expose, within the confines of realistic orientations, its most vulnerable parts to the solar radiation unless a prescribed orientation sequence is to be followed.
- c. Separated from other items that are being tested simultaneously to ensure that there is no shading of each other or blocking of air flow.

MIL-STD-331C
w/CHANGE 1
APPENDIX C

C10.5.3 Cycling. (See C10.7.5.) If the "cycling for heat effects" is selected in C10.2.1.1:

- a. Expose the test item(s) to continuous 24-hour cycles of controlled temperature and simulated solar radiation following the diurnal cycle in Table C10-I unless otherwise specified. Since relative humidity at high temperatures is difficult to control, the levels listed in Table C10-I should be regarded as desirable.
- b. The solar radiation intensity variation may be approximated by a minimum of four steps up and four steps down as shown in Figure C10-1.

TABLE C10-I. Temperature-Solar Radiation Diurnal Cycle.

Time	Temperature			Solar Radiation	
	°C	°F	RH(%)	W/m ²	BTU/ft ² /hr
0000	37	98	6	0	0
0300	34	93	7	0	0
0600	32	90	8	55	18
0900	38	101	6	730	231
1200	44	112	4	1120	355
1500	48	119	3	915	291
1600	49	120	3	730	231
1800	48	118	3	270	85
2100	41	105	5	0	0
2400/ 0000	37	98	6	0	0
Max	49	120	8	1120	355
Min	32	90	3	0	0

- c. A minimum of three continuous cycles shall be performed. It is suggested that, for most applications, the maximum test duration be seven cycles.

C10.5.4 Steady state. (See C10.7.6) If the "actinic/photo degradation effects" is selected in C10.2.1.2:

- a. Raise the test chamber temperature to 49°C (120°F), and maintain this temperature during testing.
- b. Expose the test item(s) to solar radiation at the rate of 1120 W/m² (355 BTU/ft²/hr) in accordance with Figure C10-2.
- c. A duration of ten 24-hour cycles is suggested to simulate the outdoor exposure of fuzes on a short term basis. A test duration of 56 cycles or longer is suggested for long term outdoor exposure.

C10.5.5 Return to ambient temperature. At the end of the test, allow the test chamber to return to room ambient conditions and remove the test item(s). Room temperature is +23±10°C (+73±18°F).

C10.5.6 Compliance. Analyze the test results and determine whether or not the test article meets the pass/fail criteria in C10.3.

C10.6 ALTERNATE AND OPTIONAL TESTS

None.

C10.7 RELATED INFORMATION

C10.7.1 Basis of test. This adaptation to fuzes of the MIL-STD-810 solar radiation test originated from the concerns with the impact of high temperature and solar radiation on the functioning and safety of weapons and ammunition which occurred during Operation Desert Storm (ODS). Weather data available for various locations within the ODS region indicated that air temperature often exceeded 46°C (115°F). This is air temperature only and is not indicative of the temperature of the internal components of ammunition items due to solar radiation. Solar loading may cause the internal temperature of exposed materiel to be significantly higher than the ambient air temperature. Available desert test data from an Australian study conducted in 1983 show that, due to solar radiation, temperatures can be as much as 33°C (60°F) higher than the ambient air temperature when materiel is exposed to the sun, 35°C (63°F) higher when materiel is covered with tarpaulins in contact with the ammunition, and 10°C (18°F) higher when materiel is shaded.

C10.7.2 Heating effects. The heating effects of solar radiation differ from those of high air temperature alone in that the amount of heat absorbed or reflected depends on the roughness, color, and reflectivity of the surface on which the radiation is incident. Also, directional heating induces temperature gradients across materiel. In addition to the differential expansion between dissimilar materials, changes in the intensity of solar radiation may cause components to expand or contract at different rates, which can lead to severe stresses and loss of structural integrity. Possible heating effects of solar radiation include:

- a. Mechanical - Expansion may cause jamming or loosening of moving parts. Soldered seams may weaken. Lubricants may evaporate or migrate.
- b. Electronic/electrical - Resistance, inductance and capacitance parameters may change. Contacts may open or close by warping under expansion.
- c. Lenses - Lenses or glass covers may become opaque.
- d. Explosives - Explosive material may exude.

C10.7.3 Actinic effects. While heating effects are caused by the infrared portion of the solar spectrum, physical degradation from solar energy can also occur from the ultraviolet or even the visible portions of the spectrum. Possible actinic effects of solar radiation include deterioration of natural and synthetic elastomers and polymers through photochemical reactions. Photo degradation can cause fading of paints which, in turn, can cause increased heating.

C10.7.4 Selection of test options and conditions.

C10.7.4.1 Options. The choice of test procedures is based on the following:

- a. The anticipated exposure circumstances.
- b. The expected problem areas within the test item.
- c. The duration of exposure to solar radiation.

C10.7.4.2 Conditions. The related test conditions that are used during the test are determined by:

- a. The anticipated areas of deployment.
- b. The test item configuration.

C10.7.5 Diurnal cycle. The diurnal cycle is used to determine realistic response temperatures and limited actinic effects. It has a peak temperature of 49°C (120°F) and a solar radiation intensity of 1120 W/m² (355 BTU/ft²/hr), and represents the hottest conditions exceeded not more than one percent of the hours in the most extreme month at the most severe locations in those portions of the earth identified in Army Regulation (AR) 70-38, STANAG 2895, and MIL-HDBK-310. They are primarily low latitude deserts, which in addition to very high temperatures,

concurrently experience very low relative humidities and intense solar radiation. These conditions are found seasonally in the deserts of northern Africa, the Middle East, Pakistan and India, southwestern United States, and northern Mexico.

C10.7.6 Steady state option. This procedure is used to determine possible actinic (photochemical) effects of long term exposure to sunshine due primarily to the ultraviolet and sometimes, the visible portions of the solar spectrum. When simulating such effects, it is inefficient to use the cycling option since this could take months to conduct. The approach, therefore, is to use an accelerated test which is designed to reduce the time to reproduce the integrated effects of long periods of exposure. This method will give an acceleration factor of 2.5 as far as the total energy received by the test item is concerned. One 24-hour cycle as shown in Figure C10-2 provides approximately 2.5 times the solar energy experienced in one 24 hour diurnal cycle plus a 4-hour light off period to allow alternating thermal stressing and for the so-called "dark" processes to occur. To simulate 25 days of natural exposure, for instance, perform ten cycles as shown in Figure C10-2. The cycles mentioned in paragraph C10.5.4c (ten and 56) would simulate 25 and 140 days, respectively. Increasing irradiance above the specified level is not recommended because of the danger of overheating, and there is presently no indication that attempting to accelerate the test in this way gives results that correlate with equipment response under natural solar radiation conditions. Sufficient cooling air should be maintained to prevent the test item from exceeding temperatures that would be attained under natural conditions (such as the cycling option simulates), so that this will not be an exaggerated test which unfairly penalizes the test item. Care must be taken to assure that the air flow is not high enough to cause unnatural cooling. Temperature sensors immediately adjacent to the test item (but far enough away not to be affected by thermal radiation from the test item) and properly shaded to negate direct solar loading effects, can be used to ensure the ambient air temperature is as required. Since the effects of ultraviolet radiation are highly dependent upon the solar radiation spectrum (as well as intensity and duration), the spectrum must be as close as possible to that of natural sunlight. The 4-hour "lights-off" period of each 24 hour cycle allows for test item conditions (physical and chemical) to return toward "normal" and provide some degree of thermal stress exercising.

C10.7.7 Depth of sand. A depth of sand of two inches is recommended. This is not a firm requirement, but is based on the judgment that portions of the test item should not be able to penetrate the sand layer to contact the chamber floor and thus permit heat transfer. Tests conducted at US Army ARDEC in 1995 showed that, with the required air flow, the air temperature one inch above the sand remained within 3°C of the bulk air temperature, the temperature of the sand one inch below the surface had no discernible effect on air temperature, and that the sand surface and air temperatures responded very quickly to changes in incident radiation. The principle effect of the sand appears to be reflection of radiation and the creation of a vertical temperature gradient in the air near the sand. The gradient is influenced strongly by air velocity. These observations apply to both steady state and diurnal variation tests.

C10.7.8 Bibliography.

C10.7.8.1 AR70-38, *Research, Development, Test and Evaluation of Materiel for Extreme Climatic Conditions*. 1 August 1979.

C10.7.8.2 MIL-STD-210, *Climatic Information to Determine Design and Test Requirements for Military Systems and Equipment*. 9 January 1987.

C10.7.8.3 MIL-STD-810, *Environmental Test Methods and Engineering Guidelines*. 14 July 1989.

C10.7.8.4 NATO STANAG 2895, *Extreme Climatic Conditions and Derived Conditions for Use in Defining Design/Test Criteria for NATO Forces Materiel*.

C10.7.8.5 Department of Defence, Australian Ordnance Council, Proceeding 14/83, *Effects of Solar Radiation on Ammunition*. 12 July 1983.

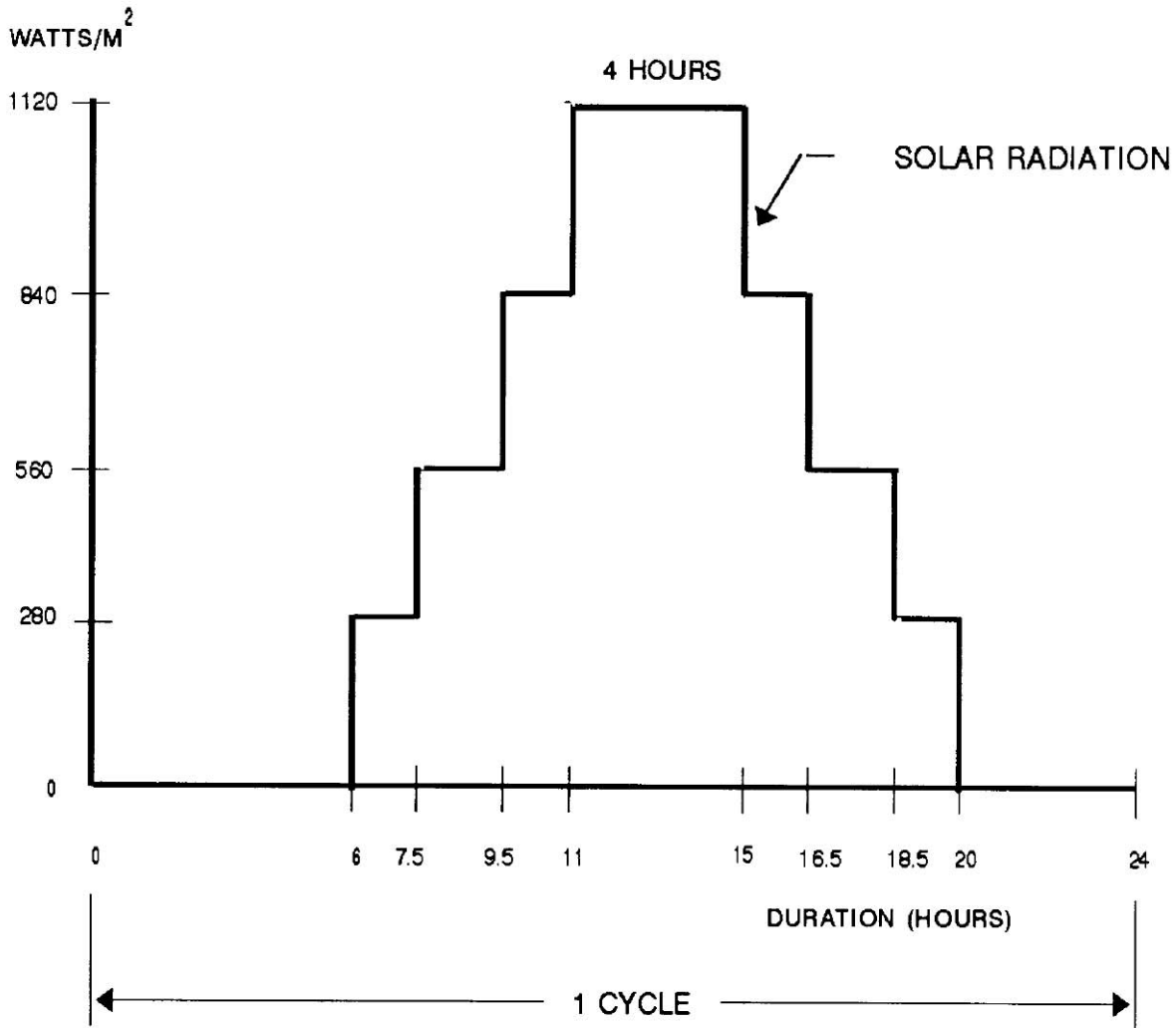

FIGURE C10-1. Simulated Solar Radiation Cycle

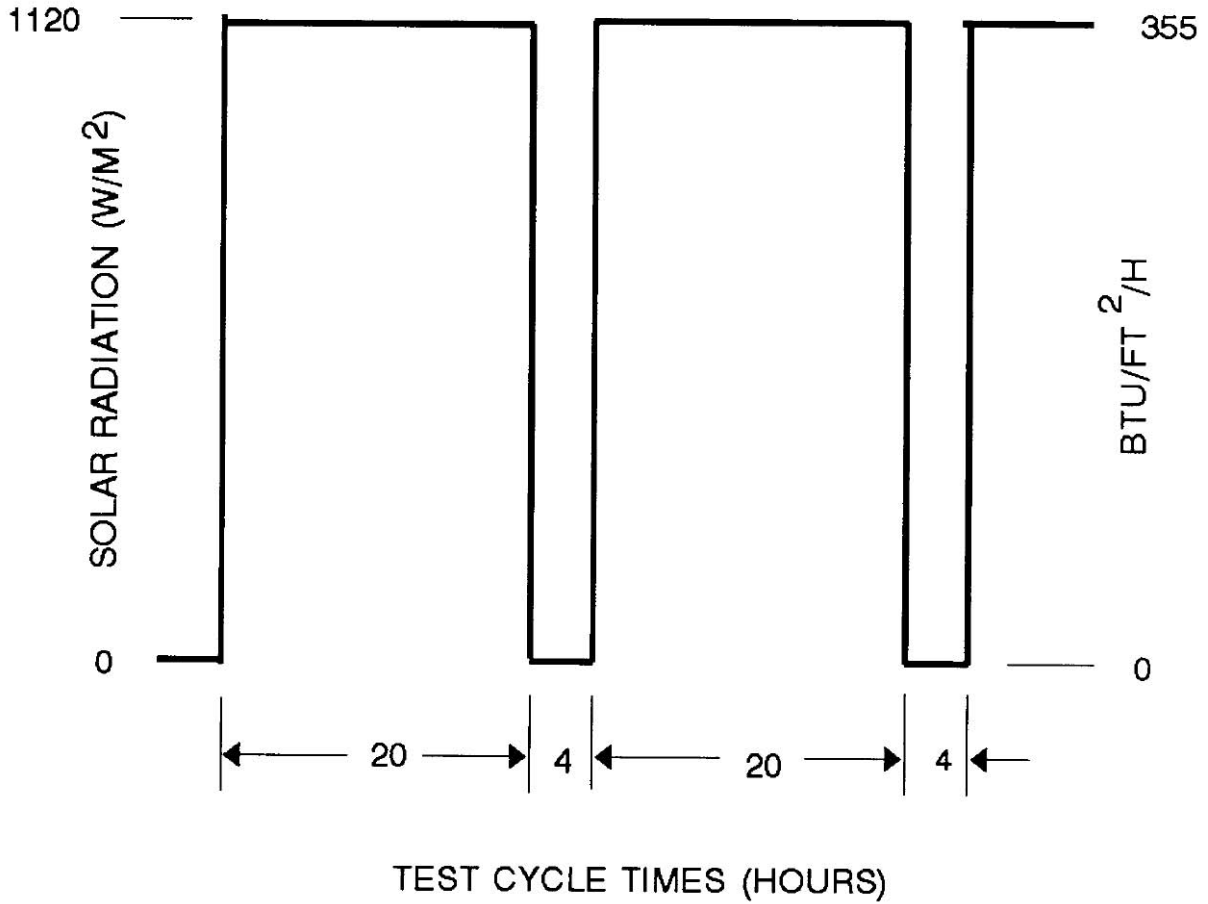

FIGURE C10-2. Two Steady State Cycles

APPENDIX D
SAFETY, ARMING AND FUNCTIONING TESTS

TEST D1

PRIMARY EXPLOSIVE COMPONENT SAFETY

D1.1. PURPOSE

This is a laboratory safety test simulating inadvertent initiation of fuze primary explosives. Explosive components beyond the explosive train interrupter must not be initiated to a high degree of reliability nor should the fuze produce a hazardous release.

D1.2. DESCRIPTION

D1.2.1 General. This test consists of two parts: the out-of-line safety test and the numerical determination of interrupter effectiveness.

D1.2.1.1 Out-of-line test. A modified fuze is mounted to a test fixture and the assembly placed in a fragmentation box. See Figure D1-1. Each sensitive explosive component in the sample fuze is fired. The effectiveness of the explosive train interrupter or any permanent barrier is then evaluated by determining whether or not there was initiation or incipient initiation of lead or booster explosives or ejection of parts, deformation, or shattering which might result in unsafe conditions. All primary explosive components, regardless of location within the fuze, shall be considered. Generally, such components are located in the explosive train before the interrupter. However, some primary explosive components may be located outside of the explosive train to serve a purpose other than initiation of the lead or booster charge.

D1.2.1.2 Interrupter effectiveness test. The numerical effectiveness of the interrupter is determined using one of the alternate and optional tests of D1.6 or using the Progressive Arm Test of D8. The choice of test must be made with regard to the fuze design and function.

D1.2.2 Fuze configuration. All fuze explosive elements shall be present in the fuze during the test.

D1.2.3 Applicable publications. All standards, specifications, drawings, procedures and manuals, which form a part of this test, are listed in Section 2 of the introduction to this standard.

D1.2.4 Test documentation. Test plans, performance records, equipment, conditions, results, and analysis shall be documented in accordance with 4.8 of the general requirements to this standard.

D1.3. CRITERIA FOR PASSING OUT-OF-LINE SAFETY TEST

D1.3.1 Fuze condition. There shall be no detonation, fragment penetration, perforation, burning, charring, scorching, or melting of any explosive component after the explosive train interruption. There shall be no ejecta which could cause serious personnel injury or initiation of adjacent fuzes. Smudging of the surfaces by soot is acceptable. Indentation of the explosive components after the interrupter is not in itself, a sufficient cause for stating that the fuze has failed. For such an occurrence, an increased sensitivity test such as those described in D1.6 must be performed.

D1.3.2 Evaluation of fragmentation box. During the test there shall be no hazardous ejection of parts or hazardous fragmentation of the confining structure as evident from the perforation of the paper liner or fiberboard. The following criteria provide a

MIL-STD-331C
w/CHANGE 1
APPENDIX D

quantitative method for determining the likelihood of injury to personnel resulting from fuze breakup or ejected fragments.

D1.3.2.1 Paper liner. Any perforation of the bond paper liner indicates possible eye damage.

D1.3.2.2 Fiberboard penetration. Any penetration of the fiberboard should be measured for hole diameter and depth. If penetration depth of any fragment, including steel, aluminum, plastic and so forth, is greater than the values shown in Table D1-I, then the probability of incapacitation, exclusive of eye damage, is greater than zero. P_K , the probability of incapacitation, is defined as the probability that personnel performing supply duties will be incapable of fully performing those duties. Values given in the table are for $P_K = 0$. The dimension (diameter and penetration) of the hole should be used to enter into the table. A graphic representation of this data is shown in Figure D1-2.

TABLE D1-I. Penetration In Fiberboard vs. Hole Size Diameter - $P_K = 0$.

Hole diameter in mm (in) - Note a	Maximum Penetration In mm (in) - Note b
0.94 (0.037)	23.6 (0.929)
2.00 (0.079)	13.2 (0.518)
4.37 (0.172)	7.26 (0.286)
9.40 (0.370)	4.04 (0.159)
20.2 (0.796)	2.24 (0.088)

Notes:

- Assumes a cubical steel fragment.
- Maximum penetration of fiberboard for $P_K = 0$ for 1/2 day supply, lightly clothed casualty criterion given in BRL Report 1269 (S). The report explains this criterion as follows: "1/2-day" indicates that the personnel will seek medical attention for the wound within 12 hours. "Supply" describes "person standing in an ammunition line receiving light loads from his right and passing them on to the man on his left;" that is, a man, standing, using his arms, but not engaged in any sort of locomotion. "Lightly clothed" indicates that the person's clothing offers him no protection against fragments of any size.

D1.3.3 Decision basis. Breakdown, inspection, other appropriate tests and engineering judgment shall form the basis for the decision that fuzes have passed or failed the test.

D1.4. EQUIPMENT

D1.4.1 Test fixture. A fixture designed to hold the test fuze and to permit firing of the primary explosive components inside the fuze will be required. The fixture shall hold the test fuze in a manner to retain, as nearly as practical, the same confinement for the expanding gases and fragments as exists in the unmodified fuze.

D1.4.2 Fragmentation box. A suitable box shall be made from cellulosic fiberboard conforming to the specifications for single-ply, 12.7 mm (1/2 in) thick building board given in ASTM-C-208, or equivalent. The box shall be lined with standard 20 lb, white, spot-free, bond

paper. Paper sheet size shall be 0.43 m (17 in) x 0.56 m (22 in). The box shall have a means to secure the test fixture at its center, holding the fuze as shown in Figure D1-1. At no point inside the box shall the liner paper be more than 0.6 m (23.6 in) or less than 0.15 m (5.9 in) away from any point of the fuze.

D1.4.3 Firing mechanism. Initiation of the test fuze shall be performed by an appropriate means to retain, as nearly as possible, the explosive confinement normally present in the fuze (see Section D1.5.1).

D1.4.4 Inert rounds. Simulations of the munitions (projectiles, bombs, rockets, and so forth) for which the fuze is designed shall be provided if additional assembled round tests using such simulations are called for at the end of the fuze test (see Section 5.6). The simulators shall be loaded with an inert filler approximating the mechanical strength of the explosive. If a more searching test is required, the simulators may be partially loaded with an explosive filler, holding the amount to a minimum. In either case, the fuze cavities shall be duplicated to accommodate the test fuze.

D1.5. PROCEDURE

D1.5.1 Modification of test fuzes. Modification of the test fuzes is generally required in order to fire their initiators in the fully assembled out-of-line position. The type of modification required varies with the fuze. In the case of stab or electric initiation, drilling a well-placed test hole as shown in Figures D1-3 and D1-4 may be all that is necessary. In another design, an entirely different approach may be needed; but in no case shall the modification significantly weaken the fuze body's ability to withstand shock waves or to contain the expanding gases or fragments.

D1.5.2 Preparation for worst-case simulation. If the fuze contains more than one component containing primary explosive, it shall be tested by functioning either simultaneously or sequentially all such components in the train, as well as the other sensitive explosives. When the fuze design permits simultaneous functioning of primary explosive components, the test shall consist of simultaneous initiation of these components if this is the worst case.

D1.5.3 Sample size and temperature conditioning

D1.5.3.1 Out-of-line test. A minimum of 15 modified and prepared fuzes shall be temperature conditioned for the test, at least five fuzes at each of the following temperatures: $+71\pm 3^{\circ}\text{C}$ ($+160\pm 5.4^{\circ}\text{F}$), $+23\pm 10^{\circ}\text{C}$ ($+73\pm 18^{\circ}\text{F}$), and $-54\pm 4^{\circ}\text{C}$ ($-65\pm 4^{\circ}\text{F}$).

D1.5.3.2 Interrupter effectiveness test. The number of fuzes will be determined by the test procedure. There is no specific requirement for the pre-test conditioning of the fuze samples and the testing conditions. However, the temperature and other pertinent environmental conditioning of the samples before and during the testing shall be recorded.

D1.5.4 Initiation in fragmentation box. Secure the test fuze and mounting fixture in the center of the fragmentation box. Fire the primary explosive component along with any other such components in the fuze by an applicable mechanism and in the manner described. Depending on the explosive content of the fuze, the use of barricades and remote control may be required for operating safety.

D1.5.5 Compliance. Remove the test fuze and witness paper from the test setup. Examine the fuze, paper and fiberboard and determine whether or not the test article meets the pass/fail criteria in Section D1.3. Continue testing the specified number of items.

D1.5.6 Fuze assembled to round. If there is any question arising from the results that there might be additional hazard with the fuze assembled to the round, the complete test

sequence shall be repeated with the fuze assembled to a test fixture, which simulates the round.

D1.6. ALTERNATE AND OPTIONAL TESTS

D1.6.1 Introduction. After the fuze design has met the specified requirements, it is recommended that additional fuzes be tested under more searching conditions to examine the effects of the explosion of the elements before the interrupter, both in the explosive train and at other locations in the fuze. The design of the explosive train interrupter should include an investigation of possible failure paths. Tests may be run with the interrupter in intermediate positions between unarmed and armed; for example, at a first-stage armed or stop position; with fuzes having extreme tolerances in critical components of the explosive train safety device; with explosive components varying in sensitivity and output from standard; or with fuzes subjected to slow or fast cook-off. All these changes should be made in such a way as to increase the probability of defeating the fuze safety barrier. Methods for doing this are described below.

D1.6.2 Possible failure paths. Figure D1-5 shows the major components of a typical explosive train. The first element is a detonator, or primer, which is responsive to either an electrical or a mechanical input. The second element is the interrupter (rotor or slider), which houses the detonator and keeps it in the out-of-line position until the proper stimulus is received, and then moves the detonator to the in-line position. The third element is the barrier between the detonator and the booster when the rotor is in the out-of-line position. The fourth element is the output lead. The output lead, booster, and warhead must contain only secondary explosives. To design tests, which will be used to evaluate an explosive train, the first step is to search out the possible failure paths by which the sensitive elements in the train might directly initiate the output lead, booster, or warhead. Figure D1-5 indicates three (3) possible failure paths, each of which may be investigated by one or more of the following techniques.

D1.6.3 Barrier thickness test. The purpose of the barrier thickness test is to establish a barrier thickness that will contain the output of the sensitive elements. If the barrier was evaluated at standard barrier thicknesses, the number of tests required would be prohibitive. To reduce the number of tests required, the test may be performed by progressively degrading, or thinning, the barriers. If the barriers are reduced by proper increments, the statistical evaluation described in Appendix G can be used to obtain a numerical effectiveness of the barrier. In Figure D1-5, the possible failure path B would be explored by progressively reducing the thickness of the barrier between the detonator and the booster. Other paths such as C, which go directly from the detonator to the warhead, would also be investigated by progressively thinning the thickness of the mechanism case, the warhead liner, or other materials between the detonator and the warhead.

D1.6.4 Increased output test. The objectives of the increased output test are (1) to provide greater confidence in the results of the barrier thickness tests, and (2) to explore the effects of the detonator variability on the safety of an explosive train. It is possible that the detonator used in the barrier thickness tests did not provide the maximum output that could be encountered. For example, the Mk 71 Detonator may have been used in these tests. This detonator, when confined in brass, has an output which results in an average dent of 0.38 mm (0.015 in) in a steel dent block. The specification for this detonator (as for most detonators) provides no maximum output requirement (that is, no specific upper limit on the explosive

MIL-STD-331C
w/CHANGE 1
APPENDIX D

capability of the detonator). Test data from production lots of the Mk 71 Detonator show dent values ranging through 0.48 mm (0.019 in). To assure that the explosive train is safe when a detonator with a maximum output is encountered, tests should be conducted with a substitute detonator whose minimum output is higher than the output of the detonators which are to be used. In case the Mk 71 Detonator is specified, a Mk 70 Detonator, which has a specific average dent capability of 0.48 mm (0.019 in), could not be used for test purposes. A detonator with a minimum output greater than 0.48 mm (0.019 in) should be used.

D1.6.5 Increased sensitivity test. The objectives of the increased sensitivity test, like the increased output test, are (1) to provide greater confidence in barrier thickness test, (2) to explore the effects of variability in the sensitivity of the acceptor explosive and (3) determine a numerical effectiveness of the barrier or interrupter. To check any of the possible failure paths indicated in Figure D1-5, it would be necessary to use explosives of increased sensitivity in the acceptors (lead, booster, or warhead). In some cases it would be impractical to duplicate the complete acceptor with more sensitive explosives. At such times, thin layers of sensitive explosive might be used to simulate the acceptor charge. A useful explosive for this test is PETN. The ratio of the sensitivity of PETN to that of other common secondary explosives, including CH-6, RDX, and some typical warhead explosives, is known. Further information on the ratios of sensitivity of various explosives, and on using the VARICOMP method to determine numerical value for explosive propagation, is contained in D1.7.2.2, D1.7.2.3 and D1.7.2.4.

D1.6.6 Cookoff test for projectile fuzes. DELETED.

D1.6.7 Fast cookoff test for fuzes. DELETED.

D1.6.8 Missing barrier test. When the presence of the interrupter acts as a barrier to the transfer of detonation, whether the interrupter contains a transfer detonator or not, and it is physically possible to assemble the device without the barrier, the probability of transfer with the barrier missing should be explored to provide confidence that malassembly will not present a significant safety hazard.

D1.7. RELATED INFORMATION

D1.7.1 Use of dimple motors. Dimple motors provide a simple means of initiating out-of-line stab primers and detonators. Electrically initiated M4 or M5 dimple-motors can be modified by attaching a striker-pin in the concave part of the metal container. When the dimple-motor is inverted by firing, the striker will impact on the stab detonator and set it off. An advantage of this approach is the small size of the motor, which can be accommodated without seriously changing the internal configuration of the fuze. Wires for firing the motor can be installed with no more difficulty than in the case of electrically initiated detonators. Actually, such a dimple-motor striker can be made even smaller than the M4 or M5, thereby reducing still further any modifications to the internal fuze geometry. The force of the striker is not critical for this test, as long as it is sufficient to reliably initiate the stab-detonator.

D1.7.2 Bibliography.

D1.7.2.1 Ballistics Research Laboratory Report 1269 (S).

D1.7.2.2 NAVWEPS Report 7411, VARICOMP, *A Method for Determining Detonation-Transfer Probabilities* (U), Naval Ordnance Laboratory, White Oak, Maryland, 30 June 1961.

D1.7.2.3 NWC TP 5789, *An Expanded VARICOMP Method for Determining Detonation Transfer Probabilities*, James E. Means, Naval Weapons Center, China Lake, CA, December 1975.

MIL-STD-331C
w/CHANGE 1
APPENDIX D

D1.7.2.4 RSLR 78-4, Safety and Reliability Testing of Fuze Explosive Trains, D. H. Chamberlain, R. Stresau Laboratories, Inc., Spooner WI, March 1978.

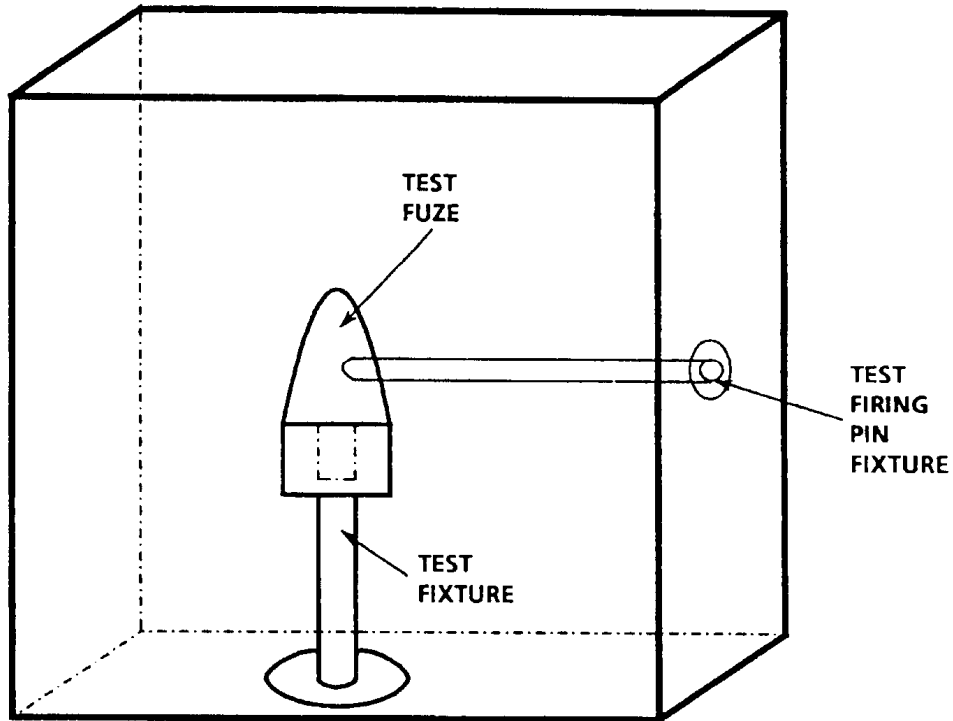

FIGURE D1-1. Fuze Installation in Test Fixture and Fiberboard Box

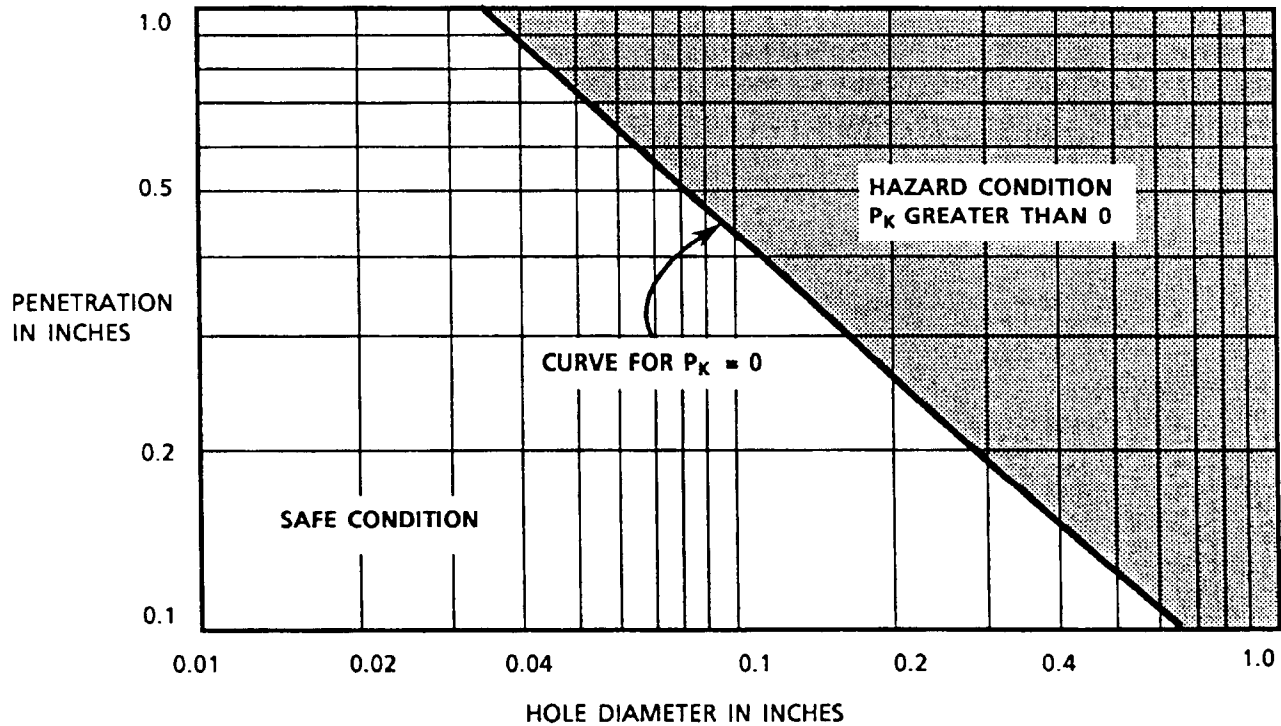
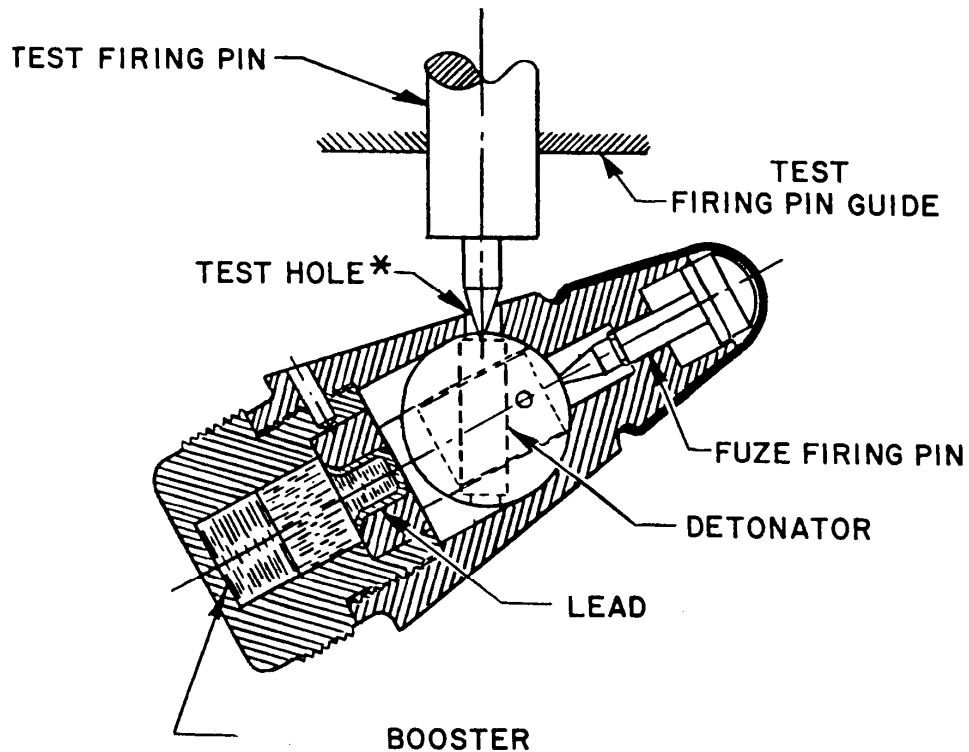

FIGURE D1-2. Penetration in Fiberboard Vs. Fragment Hole Size



* THIS HOLE IS DRILLED IN FUZE BODY IN ORDER TO INITIATE THE DETONATOR IN THE UNARMED POSITION.

FIGURE D1-3. Typical Test Arrangement for Stab Detonator Initiation

MIL-STD-331C
w/CHANGE 1
APPENDIX D

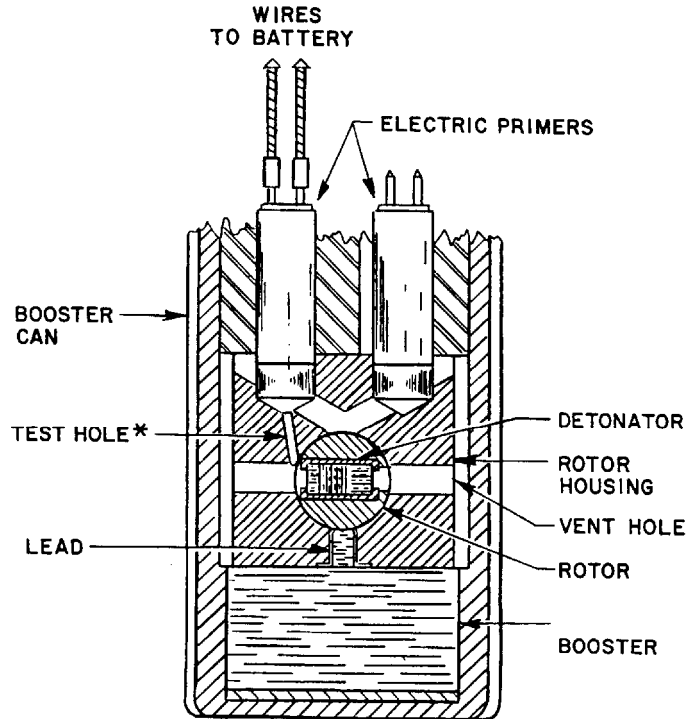

* THIS PARTICULAR FIRING TRAIN HAS TWO INITIATING PRIMERS. BY DRILLING A TEST HOLE AS NOTED ABOVE, ONE OF THE REGULAR FUZE PRIMERS CAN BE USED TO INITIATE THE DETONATOR IN THE ROTOR IN THE UNARMED POSITION. IN SOME FIRING TRAIN DESIGNS, HOWEVER, THIS IS NOT ACCOMPLISHED SO EASILY. IT IS SOMETIMES NECESSARY TO RELOCATE THE PRIMER OR TO USE ANOTHER PRIMER.

FIGURE D1-4. Typical Test Arrangement for Electric Primer Initiation

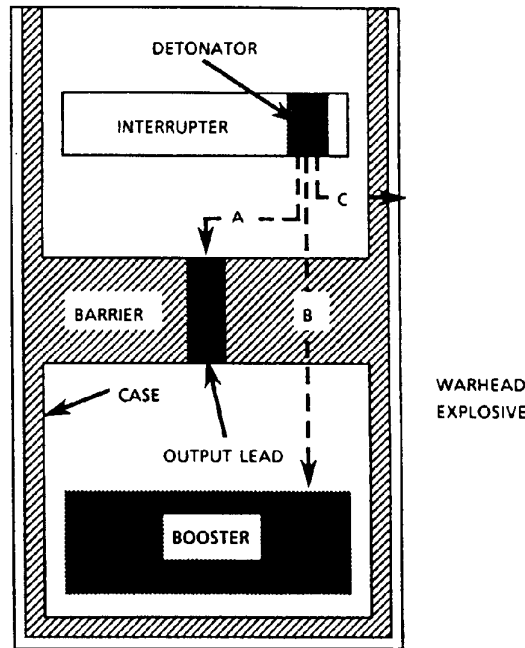

GAPS BETWEEN COMPONENTS ARE EXAGGERATED FOR CLARITY

FIGURE D1-5. Typical Components of a Fuze Explosive Train

TEST D2

PROJECTILE FUZE ARMING DISTANCE

D2.1. PURPOSE

This is a field performance test used to determine the no-arm, mean-arm and all-arm distances for impact detonating projectile fuzes. An optional field safety test is included which determines whether or not the fuze is armed at the muzzle of the gun.

D2.2. DESCRIPTION

D2.2.1 General. The fuze is assembled to the specified projectile and the round fired from a weapon against a target designed to cause an armed fuze to function. The determination of the no arm distance will help establish in-bore and close-to-muzzle impact safety. The test will also provide a reliable estimate of the maximum distance from the weapon at which the fuze will not function as a result of impact.

D2.2.2 Test configuration. The projectiles may be fully loaded or inert and, if necessary, may contain an auxiliary spotting charge to determine functioning. All of the fuze explosive elements are present in the fuze during the test.

D2.2.2.1 Arming procedure (mandatory). Target position depends on the test method selected. Fuze response is determined at each position.

D2.2.2.2 Muzzle safety procedure (optional). The target is located as closely as possible to the front of the weapon and the round fired to determine whether or not the fuze is armed when it leaves the muzzle.

D2.2.3 Applicable publications. All standards, specifications, drawings, procedures and manuals which form a part of this test are listed in Section 2 of the introduction to this standard.

D2.2.4 Test documentation. Test plans, performance records, equipment, conditions, results, and analysis shall be documented in accordance with 4.8 of the general requirements to this standard.

D2.3. CRITERIA FOR PASSING TEST

D2.3.1 Arming procedure. The resulting arming distances (no arm to all arm) shall be in accordance with the design requirements specified in the test plan.

D2.3.2 Muzzle safety procedure. No explosive elements beyond the last safety device of the fuze shall function before or as a result of impact with the target.

D2.4. EQUIPMENT

D2.4.1 Test weapons and rounds. A weapon equivalent standard test barrel and round, for which the fuze is designed, shall be used. In the case of a fuze which is standard for several rounds or weapons, a round and weapon combination shall be selected which produces the shortest no-arm distance or the longest all-arm distance, depending on the objective of the test. Other rounds and weapons may be specified in the test plan.

D2.4.2 Critical conditions and parameters of test equipment. When evaluating the no arm or all arm distance, the operation of the test fuze should be reviewed to determine critical conditions and parameters, such as temperature and barrel wear. That set of conditions and parameters, or as near as practical, shall be used which produces the shortest no arm distance or the longest all arm distance depending on the objective of the test.

D2.4.3 Target design. A target shall be used which is just thick enough to reliably initiate the armed fuze, or target requirements may be specified in the test plan. Excessive target robustness may produce fuze initiation without the fuze having fully armed.

D2.4.4 Test recorder. Photographic or other equipment capable of determining fuze functioning shall be provided.

D2.5. PROCEDURE

D2.5.1 Arming procedure. Conduct and analyze the arming test according to Appendix G. The stimulus may be the distance from a weapon muzzle to a target and the concomitant response or nonresponse may be the functioning or nonfunctioning of a fuze. The stimulus also may be the striking velocity of a projectile and the response or nonresponse, a penetration or nonpenetration, and so on.

D2.5.1.1 Probit Method. DELETED (covered in Appendix G).

D2.5.1.2 Langlie Method. DELETED (covered in Appendix G).

D2.5.1.3 OSTR Method. DELETED (covered in Appendix G).

D2.5.1.4 Bruceton Method. DELETED (covered in Appendix G).

D2.5.2 Muzzle safety procedure.

D2.5.2.1 Location of target. Set up the target as close as feasible in the front of the weapon.

D2.5.2.2 Fire and observe. Fire the round and observe whether or not the fuze functions when it strikes the target.

D2.5.2.3 Recover and examine. Recover and examine fuzes, if feasible, for adherence to D2.3.2.

D2.6. ALTERNATE AND OPTIONAL TESTS

None.

D2.7. RELATED INFORMATION

D2.7.1 Projectile Safe Separation. The need for this test arises from the fact that bursts of the projectile within and close to the weapon are dangerous to equipment and personnel.

D2.7.2 Target material. Typical targets used in this test might include wood or metal panels of various thickness and transversely or axially placed metal rods.

D2.7.3 Deflagration. This test is performed with targets which are thick enough to cause the fuze to function reliably, but not so thick as to cause an unarmed or partially-armed fuze to fire or deflagration of the filler-charge in the projectile or detonation/deflagration of the fuze booster. It should be noted that the values of no arm/all arm distance obtained in this test are applicable to the fuze alone. This overall round, even when unfuzed, may deflagrate at much smaller distance if the target is sufficiently thick. A fuze function plate should be used at or beyond the expected arming distance to confirm the proper operation of the fuze.

D2.7.4 Target position. It is necessary that the target remain in place until impact. The position of the target should be positively confirmed by using suitable instrumentation such

as high-speed photography or flash radiography, since previous experience has shown that muzzle targets can be broken or displaced by a rush of air preceding the projectile.

D2.7.5 Weapon accessories. When feasible, automatic loading mechanisms, trays or other equipment used in servicing the gun should be utilized to subject fuzes to conditions normally encountered before firing.

D2.7.6 Arming distance versus impact safe distance. Historically, the arming procedure has often been performed under the title of "impact safe distance test." This is because, for simple point detonating fuzes, the "impact-safe distance" is equivalent to the so-called "arming distance" of the fuze, that is, the distance beyond the muzzle at which the fuze becomes capable of functioning on the type of firing signal for which it was designed. For more complicated fuzes, especially those designed to operate on some triggering signal other than linear acceleration, the "impact-safe distance" may be appreciably smaller than the "arming distance," measured from the muzzle to the point in the trajectory where the fuze is "armed" both mechanically and electrically. Internal breakage, deformation of components under the strain of impact, or initiation of explosive components by the collapsing fuze may be in part responsible for this behavior. It is usually found that an explosive train can propagate an explosion wave through a fuze even though the interrupter of the train (out-of-line safety device) has not yet reached its "fully armed" position. Hence, numerical values for "impact safe distance" obtained by striking targets at various points along the trajectory (where the fuze is in a state of partial arming) will, in general, tend to be somewhat smaller than the corresponding measurements of distance to the point along the trajectory where the out-of-line safety device moves into its "fully armed" position. It is to preserve this distinction that this test was called an "impact-safe distance test" in the previous version of this test.

D2.7.7 Environmental parameters. DELETED (covered in Appendix G).

D2.7.8 References. DELETED (covered in Appendix G).

D2.7.9 Suggestions for efficient use of samples. DELETED (covered in Appendix G).

D2.7.10 Bibliography. DELETED (covered in Appendix G).

D2.7.11 Glossary. DELETED (covered in Appendix G).

TABLE D2-I. Lower tail percentiles estimated by OSTR strategies. DELETED (covered in Appendix G).

TABLE D2-II. Upper tail percentiles estimated by OSTR strategies. DELETED (covered in Appendix G).

FIGURE D2-1. Estimated Probability of Arming Versus Distance from Muzzle (Probit). DELETED (covered in Appendix G).

FIGURE D2-2. Estimated probability of arming versus distance from muzzle (Langlie). DELETED (covered in Appendix G).

FIGURE D2-3. Estimated Probability of Arming Versus Distance from Muzzle (OSTR). DELETED (covered in Appendix G).

FIGURE D2-4. Estimated probability of arming versus distance from muzzle (Bruceton). DELETED (covered in Appendix G).

TEST D3

TIME TO AIR BURST

D3.1. PURPOSE

This is a field performance test used to determine functional accuracy of mechanical and electronic projectile time fuzes.

D3.2. DESCRIPTION

D3.2.1 General. The fuze is mounted to a projectile, set to function at a predetermined time and fired on the test range. Time is measured as the interval between detection of firing and detection of functioning. Data can be used to specify single fuze limitations or group data distributions.

D3.2.2 Fuze configuration. All explosive elements shall be in the fuze during the test.

D3.2.3 Applicable publications. All standards, specifications, drawings, procedures and manuals which form a part of this test are listed in section 2 of the introduction to this standard.

D3.2.4 Test documentation. Test plans, performance records, equipment, conditions, results, and analysis shall be documented in accordance with 4.8 of the general requirements to this standard. Test plans shall include requirements for gun tube wear, elevation angle, temperature conditioning for the cartridge and fuze, and so forth, as required.

D3.3. CRITERIA FOR PASSING TEST

The criteria for passing the test shall be compliance with requirements specified in accordance with the test directive.

D3.4. EQUIPMENT

D3.4.1 Gun. A gun or mortar appropriate for the fuzed projectile and in accordance with the stage of wear specified in the test directive. See D3.7.4.

D3.4.2 Projectile. Proper explosive-loaded projectile or inert-loaded projectile with spotting charge to emit a signature at the time of fuze function and with the test fuze attached. If an inert-loaded projectile with spotting charge is used, determine by field test time measurements of the burst, that sufficient accuracy exists compared to the explosive-loaded projectile burst time.

D3.4.3 Fuze setter. An appropriate fuze setter. See D3.7.6.

D3.4.4 Instrumentation. Appropriate instrumentation to measure the time to burst. The instrumentation must be capable of measuring a time interval one-tenth (1/10) that of the smallest increment it is desired to detect. Events prior to the first movement of the projectile, including detonation of the expelling charge, and events subsequent to the projectile exiting the gun tube muzzle shall not be used to start counters or record zero time. See D3.7.1. Ensure that the time interval between first movement of the projectile and emergence of the projectile from the gun does not materially detract from the accuracy of the time to burst.

D3.4.5 Temperature conditioning equipment. Temperature conditioning equipment required by the test directive. See D3.7.2.

D3.5. PROCEDURE

D3.5.1 Instrumentation setup. Set up a minimum of three comparable instrumentation systems.

D3.5.1.1 Sensor setup. Obtain detonation or burst signature data prior to the fuze test. The rise time of visible and infrared emissions may vary considerably between explosive configurations before reaching the instrumentation sensitivity level. Aim the sensors at the function zone and adjust the sensitivity in accordance with the signature data and environmental conditions. Excessively high sensitivity results in readings from spurious emissions rather than the fuze function. Excessively low sensitivity can result in lost readings or delayed recording.

D3.5.1.2 Adjust recording apparatus.

D3.5.2 Weapon assembly. Assemble complete fuze to the appropriate projectile.

D3.5.3 Temperature conditioning. Perform the test with the fuze and other projectile and propellant charge components at ambient temperature unless otherwise specified in the test directive.

D3.5.4 Adjust elevation angle. Adjust the gun's quadrant elevation angle to that value specified in the test directive. The elevation, along with the combined gun and projectile ballistic characteristic, should yield an approximation of the function zone. Record the elevation.

D3.5.5 Remove safety equipment. Remove shipping safety wires, pins, and so forth.

D3.5.6 Set fuze. Set the fuze to the time setting specified in the test directive using a hand wrench or appropriate fuze setter.

D3.5.7 Fire adjustment round. Fire a minimum of one round to check the adjustments on all instrumentation and the location of the function zone. The gun's angle of elevation shall not be adjusted to position the air burst within view of the sensor. When adjustments are required, the sensor shall be adjusted to accommodate the specified gun elevation. If adjustments to the instrumentation are necessary, additional rounds will be fired as required. If readings cannot be obtained after testing all combinations of explosives, instrumentation adjustments and no more than a 10% elevation variation, then approval for deviations from the test directive must be obtained. Record all adjustments.

D3.5.8 Fire test rounds. Measure and record the fuze function times in seconds as indicated by the instrumentation to four decimal places or as many as applicable. Record the fuze serial number (if any) and the tube round number.

D3.5.9 Data reduction. The following procedure shall be used for data reduction.

D3.5.9.1 Averaging. The readings from the instrumentation system shall be averaged. Readings which are inaccurate due to a positive cause shall be deemed lost. Any reading, attributable to one fuze, that disagrees with all other readings for that fuze by more than two milliseconds without a justifiable positive cause shall be deemed lost. Where no two readings for one fuze agree within the two-millisecond limit, and no positive cause is found to eliminate all but one, then all readings for that fuze shall be deemed lost. The averaged reading in seconds will become the fuze function time.

D3.5.9.2 Mean and standard deviation. Where group data distributions are required, the fuze function times shall be used to arrive at a mean (\bar{x}) and standard deviation (S) in seconds. See D3.7.7.

D3.5.10 Compliance. Analyze the test results and determine whether or not the test article meets the pass/fail criteria in D3.3.

D3.6. ALTERNATE AND OPTIONAL TESTS

None.

D3.7. RELATED INFORMATION

D3.7.1 Typical time measuring systems. Stop watches, electric clocks and fuze chronographs are generally used at ordnance proving grounds for measuring the time of flight of projectiles from the gun to the point of burst. Fuze chronographs provide the most precise measurement of the three. Electric clocks offer a lower degree of precision than that of the fuze chronograph but higher than that of stop watches. Stop watches are used when convenience, rather than precision, governs the choice of a chronometer.

D3.7.1.1 Stop watches. The watches are started simultaneously when the gun is fired. Experience has shown that visual observation of a burst may involve a delay (especially at long ranges in daylight) for the burst to develop to visible size. This delay is estimated to be on the order of 0.1 second. Where this has been determined by experiment, it should be applied. Generally, two or more observers with stop watches are employed for a given time to burst measurement. An individual observer operates each stop watch. One stop watch observation should be used only when an approximate value is required during preliminary tests. When two or more observers are timing, the average time is calculated. Before averaging the time values obtained for each round, discard all values known to be in error. The allowable deviation between any two observed time values is 0.1 second. When the deviation is constantly greater than this value, the cause should be determined and corrected.

D3.7.1.2 Electric clocks. Three or four clocks are usually employed for a given time of flight measurement. The clock motors are simultaneously started by making an electrical contact when the gun is fired. For this purpose, a mercury switch or a mechanical type inertia switch attached to one of the recoiling parts may be used. For a non-recoiling type of gun, such as a mortar, a circuit employing a coil at the muzzle of the gun is satisfactory. In using the latter method, the projectile is usually magnetized. The operation of each clock is stopped by an individual observer who trips a microswitch when he sees the burst of the projectile. The time increment shown on the dial of each clock is recorded by the clock operator, and the pointers are reset at zero for the next round. A constant frequency power source is necessary to ensure uniform timing by the clock. In averaging the time observations, readings differing 0.06 second or more from the shortest time will be discarded. This is based on the assumption that the observer having the quickest reflex action normally records the shortest time. Since the clocks are set automatically and stopped manually, a correction must be applied to the time obtained by this method. Experience has shown the average correction to be minus 0.2 second. This correction includes human reaction time and the time required for the burst to become visible.

D3.7.1.3 Fuze chronograph systems. A fuze chronograph system consists of four elements. There are: (1) a starting switch used to identify projectile launch time (considered fuze start time); (2) a sensor or detector capable of identifying fuze functioning; (3) pre-amplifiers and amplifiers used to increase the output signal from the sensor; and (4) some type of timing device. The fuze chronograph is an electrical system designed to automatically measure the time between fuze launch and fuze function. The system may be subject to gross error due to spurious emissions and some method of verifying the function or nonfunction is recommended. This may be accomplished by close agreement of times from two or more independent chronograph systems confirmed by observers with manual timers. Another method would use magnetic tape records of the gun firing events; the incoming burst signature, and the amplifier output pulse. Analysis of these records could serve to confirm functioning.

D3.7.1.3.1 U.S. Army Test and Evaluation Command fuze chronograph. The chronograph is capable of measuring the time to burst of existing MT fuzes within 0.01 second. The chronograph, however, does not have uniform precision when testing all types of fuzes. Under ideal conditions, the degree of precision depends upon many variables such as the explosive train of the fuze. For example, a precision of 0.6 millisecond (one standard deviation) is obtainable when measuring time to burst for a Fuze, MTSQ, and M564. The U.S. Army Test and Evaluation Command Fuze Chronograph System consists of the following:

- a. **Starting switch.** The most common method of identifying the instant of projectile launch is the use of an inertia switch mounted on the gun tube. Upon gun recoil, the switch through appropriate circuitry identifies time "zero" by starting the electronic counter or otherwise manifesting zero time on a timing device. The present microswitch used is a heavy duty, general purpose, and precision snap switch. It is leaf-activated, requires a maximum force of 71 g (2.5 oz) to operate and a minimum force of 14.2 g (0.5 oz) to release, has 12 mm (15/32 in) maximum pre-travel and 4.2 mm (1/6 in) minimum over travel and a maximum movement differential of 2.2 mm (0.085 in). The pre-travel has been reduced to about 4.2 mm (1/6 in) by a mechanical stop on the mounting bracket which prevents the actuation leaf from returning to its normal rest position. The actuating leaf and roller provide a mass for the inertial actuation of the switch. Other devices such as coils, blast switches or photocells could be used to perform the starting function.
- b. **Sensor.** - An infrared INFRATRON lead sulfide detector with a sensitive area of 8 mm (0.315 in) square and a long pass optical filter ($\lambda_c = 1.8$ micrometers) is mounted in a specially fabricated telescope housing. This uses a reflector mounted in a rearward end of the telescope housing instead of a lens. The reflector is a 114.3 mm (4.5 in) diameter parabolic type with a focal length of 50.8 mm (2 in). Optical characteristics of the system limit the field of view to approximately 7 degrees. A sketch of the infrared telescope assembly is shown in Figure D3-1.
- c. **Amplifier.** A transistorized condenser coupled amplifier; input impedance of one mega ohm; overall voltage gain of 2000 maximum; frequency response of 2 Hz to 5000 Hz at half power points; output of 15 V positive pulse, 200 s duration increases the output signal from the sensor and provides a "stop" signal. The input circuitry consists of a field effect transistor to match the detector impedance.
- d. **Timing device.** Any standard electronic timer and printer with an input impedance of 200,000 ohms or greater and a printing rate of three (3) lines per second with a six (6) to eight (8) digit readout or similar characteristics can be used with the unit.
- e. **APG spotting charge.** The APG spotting charge was developed for use with this system. It consists of a 70/30 mix (by weight) of 77.8 g (1200 grains) of propellant, M9 composition, 0.76 mm (0.0030 in) web, flaked for 60 mm mortar and 32.4 g (500 grains) of aluminum powder, atomized Type C, Class D, loaded into a modified 88.9 mm (3.5 in) long aluminum liner for deep cavity loaded projectiles. The aluminum liner is capped with an 1 mm (0.040 in) hole in the center. A special onionskin paper covers the hole to prevent the powder from escaping. A 24.8 g (382 grain) black powder pellet, Grade FFFG, 38.1 mm (1.5 in) diameter, 12.7 mm (0.5 in) thick (black powder mixed with 2% powdered graphite for binder) is placed on top of the charge after inserting it into the shell cavity. See Figure D3-2.

D3.7.1.3.2 Naval Surface Warfare Center burst time indicator.

a. Instrumentation.

(1) Sensors

(a) Ten degree field of view Cassegrain Systems with lead sulfide detectors (Barnes Radiometers Model R8T-1A).

(b) Sixty degree field of view refractors with lead sulfide detectors and germanium lenses (Barnes special order - no model number).

(2) Time Interval Counters (Darcy Company Model 361-R).

(3) Printer (Franklin Electronics, Incorporated Model 220D-19-2B22F).

(4) Magnetic Tape Recorders (Sangamo Models 4700/3600).

(5) Instrumentation Amplifiers (INCOR Model 110A).

(6) Oscillograph (Honeywell Model 1508).

(7) Calibrated Standard Time Mark Generator (Tektronics Model 184).

b. Procedure. The procedure used to measure time-to-air burst is to record close of firing key, muzzle flash (using a refractor) timing pulses and radiometer and/or refractor signal on magnetic tape. Simultaneously, the time interval counters are triggered and the time-to-air burst is displayed and printed. This same information is then recorded on the oscillograph for a visual record which may be used for comparison and verification. The timing accuracy of the system is +/- one (1) millisecond.

D3.7.2 Temperature. The time to air burst may be affected by the temperature of the fuzes at the time of the test. The rate powder trains burn, the viscosity of lubricants and the performance of electrical components are typical factors which may be affected. Therefore, complete rounds may require temperature conditioning prior to test firing. Temperature conditioning time varies considerably with the size of ammunition and characteristics of conditioning equipment. The time chosen should ensure that all components are at temperature equilibrium. The round should be fired as quickly as possible (5 minutes maximum) after removal from conditioning and the time interval recorded. Reconditioning after five minutes have been exceeded is specifically prohibited unless waived by the procuring agency.

D3.7.3 Varying round parameters. Air burst tests should, at a minimum, include firings at maximum and minimum acceleration conditions and at maximum, intermediate and minimum fuze time settings. Additionally, firings at intermediate accelerations and extreme temperatures have, in the past, pointed to problems in fuzes and thus may also be desirable.

D3.7.4 Tube wear. A worn tube (last one-third of life) is frequently used with maximum and minimum service charges to subject the fuzes to maximum and minimum acceleration conditions under the worst conditions of balloting of the shell.

D3.7.5 Gun elevation angles. The gun elevation angles prescribed in the test directive must be strictly adhered to in testing powder train fuzes, since the burning rate of the powder train is affected by the variation in air density. The effect of air density on the functioning of mechanical time fuzes is not so pronounced; therefore, the gun elevation angles may be varied several degrees to suit weather conditions. Deviation from the prescribed elevation angle should be held to a minimum, since the timing of the mechanical time fuze may be affected by decay in spin, which varies with the air density. The gun elevations should be chosen to be consistent with field usage.

D3.7.6 Automatic loading and setting equipment. If automatic loading and setting

equipment is used to service the gun, it should be used in firing a portion of the fuzes submitted for the test. If the results obtained with hand set and automatically set fuzes are not in agreement, the error of the automatic setter should be investigated before it is concluded that the fuze is affected by the operation of the automatic equipment.

D3.7.7 Data reduction. In reducing data to a form comparable to the requirements in the test directive, care must be used to avoid statistical errors. In many cases, the data accumulated by utilizing the method presented in Section D3.5 will conform to the normal distribution. This can be assumed but the data must be checked to determine the validity of such an assumption. If the distribution is assumed to be normal, the following formula may be used to determine the mean (\bar{X}) and standard deviation (S).

$$\text{Mean: } \bar{X} = \frac{\sum X}{n}$$

$$\text{Standard deviation: } S = \sqrt{\frac{n\sum X^2 - (\sum X)^2}{n(n-1)}}$$

where:

- \bar{X} = arithmetic average of all values in milliseconds,
- X = a measured burst time in milliseconds,
- s = standard deviation, and
- n = number of functioning times used.

D3.7.7.1 Sample size. The number of functioning times used to obtain the \bar{X} and S can affect the confidence in the calculations. Care must be exercised in determining the initial sample size to assure that the calculated values are not biased because the sample size is too small. The recommended sample size for a normal distribution is 20 samples. Where the number of statistically normal time values obtained for a particular test phase is less than required because of the elimination of values due to duds, lost times, outliers or other discrepancies, additional samples should be tested.

D3.7.7.2 Outlier data. Where a particular functioning time in a test appears not to belong to the rest of the test population, and no apparent positive cause exists, a test for outliers may be applied to the value. Since outliers are nebulous in nature, and since there are various methods and justifications for those methods, the outlier procedure and criteria should be specified in the test directive. Where no method and/or criteria are specified in the test directive, the method described in AMCP 706-113, 17-3.1.1 shall be used for Alpha = 0.10.

D3.7.8 Definitions.

D3.7.8.1 Signature data. The level of emissions from the detonation of the fuze and projectile train, that is higher than the environmental emissions, and significantly sufficient to cause triggering of the counter with a minimal time delay.

D3.7.8.2 Accuracy. The fuze timing requirements specified in the test directive, and the measured and calculated values for the fuze sample arrived at by use of this test.

D3.7.8.3 Precision. The ability of the equipment to measure the fuze functioning times to the required degree of accuracy.

D3.7.9 Photographs. It may be desirable to document the time setting prior to firing using photographs. In cases of extraordinary function times, the photographs could be developed and determine if the fuzes were set improperly.

D3.7.10 Bibliography. AMCP 706-113.

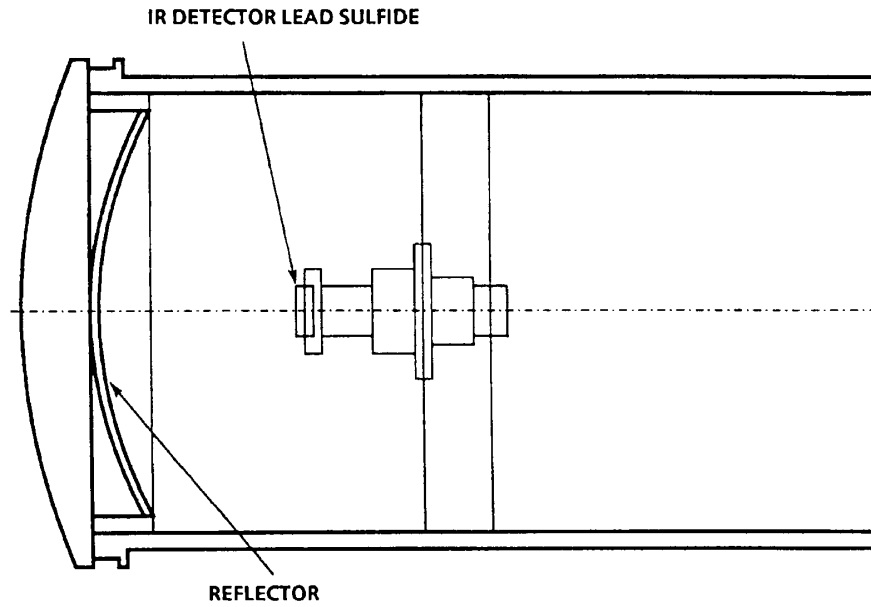

FIGURE D3-1. Infrared Detector Assembly

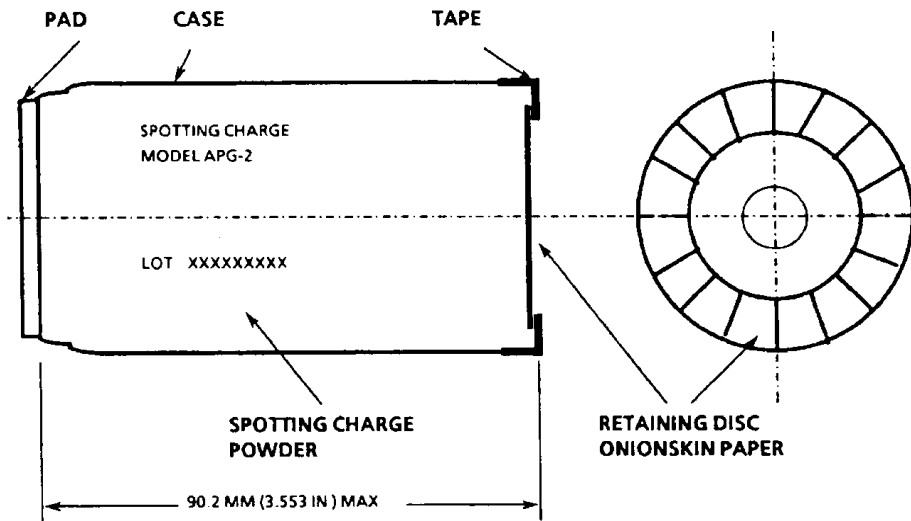

FIGURE D3-2. Spotting Charge, Model APG-2

TEST D4

EXPLOSIVE COMPONENT OUTPUT

D4.1. PURPOSE

This is a laboratory performance test used to determine explosive component performance and uniformity.

D4.2. DESCRIPTION

D4.2.1 Methods. A fuze explosive component is initiated in contact with metal stock of known uniformity and consistency. The resulting dent or perforation in the adjoining metal is measured. Statistical procedures, such as calculation of the mean and standard deviation, are performed following the completion of the specified number of tests. As an option, the test plan shall specify whether or not the explosive component must be confined to the space allocated in the intended fuze. When required, confinement is generally provided by an appropriate sleeve, but the actual fuze body may also be specified. This test provides two methods to record and measure the output.

D4.2.1.1 Dent block method. The explosion produces a measurable dent in a steel or aluminum block. Selection of either steel or aluminum depends on the output level of the explosive component. In order to ensure the most accurate measurement, steel blocks shall be used for testing components which generally produce dents less than 25.4 mm (1.0 in) but greater than 0.13 mm (0.005 in) in steel. Aluminum blocks shall be used for smaller components generally producing dents less than 0.13 mm (0.005 in) in steel and greater than 0.13 mm (0.005 in) in aluminum. The disk perforation method shall be used if the component cannot produce a 0.13 mm (0.005 in) dent in aluminum. This test is not suitable for components that produce irregular or asymmetrical dents. Best results are obtained from components that produce essentially smooth, flat-to-slightly curved dents.

D4.2.1.2 Disc perforation method. The explosion produces a hole or perforation in a thin metal disc. The diameter of the hole is then measured. Lead and aluminum are presently used as material for the discs. For explosive components with low output, the discs may be coined.

D4.2.2 Multiple-element tests. In addition to measuring the output of separate explosive components, the dent block method is useful in evaluating the performance of two or more components which must function together in a fuze. In these cases, unique test fixtures or the use of the actual fuze body must be specified in the test plan.

D4.2.3 Applicable publications. All standards, specifications, drawings, procedures and manuals which form a part of this test are listed in Section 2 of the introduction to this standard. Special attention is directed to D4.4 of this test which recommends materials to be used for dent blocks, perforation discs and confinements.

D4.2.4 Test documentation. Test plans, performance records, equipment, conditions, results and analysis shall be documented in accordance with 4.8 of the general requirements to this standard. A notation shall be made on the test report as to the confinement used, that is, air, brass, polystyrene, steel, aluminum, and so forth.

D4.3. CRITERIA FOR PASSING TEST

The criteria for an acceptable explosive component in a particular application will be specified in the test plan. For the dent block method, this is usually stated as minimum depth, average depth, or depth with tolerances. For the disc perforation method, output is typically stated as a minimum or average diameter hole in the disc.

D4.4. EQUIPMENT

Equipment required for this test consists of an initiation device for the explosive component, a test fixture to hold the dent block or disk and component in place, the dent block or disc and a suitable instrument to measure the depth of the dent or diameter of the perforation. Table D4-I lists numerous initiating devices, test fixtures, dent blocks, perforation discs and measurement equipment which have been developed and used over the years and are suitable for testing a wide variety of small explosive components. The use of appropriate parts listed in this table or other suitable material shall be specified in the test plan. Some typical test arrangements are shown in Figures D4-1 and D4-2.

D4.4.1 Initiation device. Selection of an initiation device depends on the type of explosive component being tested. In any case, the initiator must produce sufficient output to ensure reliable detonation of the component being tested.

D4.4.1.1 Ball drop tester. A ball drop tester is used for stab- and flash-initiated explosive components. Typically, a steel ball is dropped from a specified height, impacts a firing pin which in turn is driven into the explosive component with sufficient force to initiate the explosive. In the case of a flash-initiated device, the required flash is produced by first initiating a suitable stab primer which in turn produces a flash to initiate the component under test.

D4.4.1.2 Electric circuits. Suitable current sources are used to initiate electric explosive components. The circuits shall contain a shunt switch to maintain a shorted condition across the test component leads while the test is being set up.

D4.4.2 Dent block. When using the dent block method, a new dent block must be used for each test firing. The block shall be clean and free from rust and burrs. Size of the dent block depends on the test configuration. It shall conform to one of the following specifications.

D4.4.2.1 Steel. The steel block is cut from cold-finished (cold-drawn or cold-rolled) bars in accordance with ASTM-A-108 No. C1018 or C1020 having a hardness of Rockwell B70 to B95. Hardness shall be measured on the rolled or drawn surface. A light film of machine oil may be used as a preservative.

D4.4.2.2 Aluminum. The aluminum block shall be cut from aluminum alloy bar conforming to either Federal Specification SAE-AMS-QQ-A-225 and ASTM-B211 for 2024 T351 material having a hardness of 120 to 130 Bh 10/500/30, or Federal Specification SAE-AMS-QQ-A-225 and ASTM-B211 for 6061 annealed material having a hardness of 30 to 35 Bh 10/500/30. Hardness shall be measured on the surface as rolled or drawn.

D4.4.3 Perforation disc. When using the disc perforation method, a new disc is required for each test. The disc may be chosen from Table D4-I.

D4.4.4 Test fixture. The test fixture is an assembly of parts used to hold the explosive component and the dent block or perforation disc in proper position. Selection of parts depends on the size and shape of the explosive component being tested, as well as the purpose of the test. Refer to Table D4-I.

D4.4.4.1 Confinement device. The fixture may include a separate confinement device such as a sleeve or the actual fuze body. The minimum length of each sleeve shall equal the

length of the component. The inside diameter of the sleeve shall not be more than 0.05 mm (0.002 in) greater for metal or 0.13 mm (0.005 in) greater for plastic than the maximum allowable diameter of the component. Engineering judgment shall be used to determine confinement for odd-shaped components. Sleeves may include provisions for the simulation of the explosive train, for example, metal barriers, air gap, and so forth, or an in-line system.

D4.4.4.2 Adhesive. For the dent block method, silicone compound, SAE-AS8660 or double-stick tape shall be applied between the explosive component and the dent block.

D4.4.5 Measurement devices. Depending on the test method, one of the following shall be used to measure the dent or perforation:

D4.4.5.1 Height gage. A dial indicator or equivalent height gage, graduated in at least 0.03 mm (0.001 in) units and accurate to at least 0.013 mm (0.0005 in), shall be used for measuring the depth of the dent. The gage probe shall have the point shown in Figure D4-3.

D4.4.5.2 Conical plug gage. A conical plug gage may be used as an option to Test Set Mk 170 Mod 0 for measurement of disc perforations. It shall have a taper which does not exceed 1.02 mm (0.030 in) change in diameter per 25.4 mm (1 in) of length. See Figure D4-1 (E).

D4.4.5.3 Test Set Mk 170 Mod 1. This test set may be used as an option to the conical plug gage to optically measure the hole diameter. See Figure D4-2 (D).

D4.5. PROCEDURE

D4.5.1 Safety precautions. Since this test is conducted with explosive material, adequate safety precautions must be taken during handling and testing.

D4.5.1.1 Barricades. Suitable barricades must be used to protect personnel from fragmentation.

D4.5.1.2 Ventilation. The area shall be well ventilated or a fume hood must be used, to prevent the test operator from inhaling toxic fumes.

D4.5.1.3 Delay time. In case of a test malfunction of long delay explosive components, adequate time shall be allowed before approaching the test setup.

D4.5.1.4 Removal, breakdown and inspection. Removal of the explosive component or fuze from the test setup at the end of the test and any subsequent breakdown or inspection shall be done in such a manner as to protect personnel from injury if accidental detonation occurs. Safety shall be established prior to direct handling, breakdown and inspection. If the condition of the test material is in doubt, safety shall be established by radiographic inspection or other non-destructive and non-hazardous methods.

D4.5.2 Test setup. Assemble the initiation device, test fixture, explosive component, and dent block or perforation disk. The detonator should be located approximately in the center of the dent block or perforation disk.

D4.5.2.1 Adhesive. In the dent block method, apply a thin coat of silicone compound, SAE-AS8660 or a piece of double-stick tape between the explosive component and the dent block. This does not influence the depth of dent. It will ensure good contact between the two pieces and prevent the bottom of the explosive component from embedding in the dent block.

D4.5.2.2 Ball drop tester alignment. When a ball drop tester is used for stab-initiated devices, it must be aligned with the firing pin. This is most easily done by placing a small piece of carbon paper on top of the firing pin which is supported in the assembled position by an inert primer or detonator. If dropping the ball on the firing pin produces a mark which is not centrally located on the top of the firing pin, the position of the drop magnet must be adjusted through

means provided in the testing fixture.

D4.5.3 Firing. After proper steps have been taken to assure personnel safety, fire the initiating component.

D4.5.4 Measurement. Disassemble the test fixture and remove the dent block or perforated disk.

D4.5.4.1 Dent block. Before measurement, remove any foreign deposits from the dent and burrs from the block. Refer to Figure D4-3. Zero the indicator with the point of the probe in the deepest part of the dent. Remove the point of the probe from the dent and take readings at two or four points on opposite sides of the dent block. These points shall be outside of the dent and a minimum of 3.2 mm (1/8 in) away from the cut face edges of the dented surface, approximately equally spaced from the center of the dent. The average of the readings is the depth of the dent.

D4.5.4.2 Perforation disc. If a conical feeler gage is used, place the concave side of the disc on the gage using fingertip pressure. The gage is read from the convex side. If an optical measurement device is used, follow the instructions supplied with the machine.

D4.5.5 Analysis. After the specified number of components has been tested, perform the required statistical analysis such as calculation of the mean and standard deviation.

D4.5.6 Compliance. Analyze the test results and determine whether or not the test article meets the pass/fail criteria in D4.3.

D4.6 ALTERNATE AND OPTIONAL TESTS

None.

D4.7 RELATED INFORMATION

D4.7.1 Limitations. Explosive propagation depends on the characteristics of the component under test, as well as its intended application. Terms such as output, impulse, energy, brisance, strength, and power are used in a general sense when applied to this test. This test involves deformation or perforation of material which can be uniformly controlled in manufacture. In practice, this test is only useful to determine explosive component uniformity within samples. If a satisfactory correlation between the results of this test and functioning in the intended application has been established, the results of this test may be extended to predict operational functioning or failure.

D4.7.2 Accuracy range for dent block test. Experience has shown that dent block tests are usable for dents between 0.03 mm and 2.54 mm (0.001 and 0.100 in) deep, but very accurate depth measuring instruments are needed to obtain useful results in the lower depth range. That is why this test applies only to components producing dents greater than 0.13 mm (0.005 in) and less than 2.54 mm (0.100 in) in depth.

D4.7.3 Application of disc test. The lead disc test has been used for many years. Much information has been accumulated regarding the behavior of a wide variety of explosive components. In its present application, the test is not intended as a substitute for explosive train tests, but may permit the designer to determine a suitable output range before the explosive train design has progressed to a point where major changes introduce substantial costs.

D4.7.4 Use of Grade B lead. Federal Specification QQ-L-201, Grade B lead may contain 0.50% maximum foreign material in any proportion. Grade C lead permits only 0.10% maximum foreign material, and these are limited in concentration. Comparison tests were conducted to determine the effects of each type lead on the perforations produced by a

MIL-STD-331C
w/CHANGE 1
APPENDIX D

standard explosive component. Results of these tests have shown that the perforation is unaffected by the use of either grade of lead as long as the prescribed disc thickness is used. The use of discs which do not fall within the required thickness 3.416 ± 0.0254 mm (0.1345 ± 0.0010 in) may result in errors in the determination of the output of the explosive component. Cost considerations were used as the basis for the selection of Grade B lead for use with this standard. However, it should be noted that this selection does not preclude the use of Grade C lead.

D4.7.5 Variation of confinement sleeves. Plastic or metal may be used for confinement sleeves. See Table D4-I. Experience has shown that with two confinements, one weak and one strong, it is possible to detect changes in variables that may not be revealed using only one confinement. Such variables include loading pressure and column length of the explosives.

D4.7.6 Testing percussion-initiated explosive components. Percussion-initiated explosive components may be tested using fixtures similar to those shown for stab-initiated components. The firing pins used in the fixtures should be modified to have hemispherical ends instead of a point. A typical pin end would have a radius of 2.36 mm (0.093 in).

D4.7.7 Bibliography.

D4.7.7.1 Navy Ordnance Report 2422, *Small Scale Plate Dent Test for Confined Charges*, Naval Sea Systems Command, Washington, DC, 1952.

D4.7.7.2 Navy Ordnance Report 3879, *Application of the Small Scale Plate Dent Test to the Quality Control of the Mk 63 Detonator*, Naval Sea Systems Command, Washington, DC, 1955.

D4.7.7.3 Condition *Behind the Reaction Zone of Confined Columns of Explosive. Notions Derived from Plate Dent Experiments.* Slie - Second ONR Detonation Symposium, 8, 9, 10 February 1955 (CONFIDENTIAL).

D4.7.7.4 Naval Ordnance Report 2932, *Investigation of Mark 18 Torpedo Failures*, Naval Sea Systems Command, Washington, DC, 25 August 1953.

D4.7.7.5 Naval Ordnance Report 2815, *Direct Initiation of Booster by Electric Initiators*, Naval Sea Systems Command, Washington, DC, 13 March 1953.

TABLE D4-I. Optional Test Equipment

User	Dwg/Spec	Part	Description
Initiating Devices			
Army	81-3-150	Ball Drop Tester	Stab- and flash-initiated tests.
Navy	LD 166 538	Mk 136-0 Test Set (ball drop)	Stab- and flash-initiated tests.
	LD 166 539	Magnet Adjusting Unit	
	553 491	Test Ball	57, 113 & 454 g (2, 4 & 16 oz) sizes.
Army	9 218 452	M55 Stab Primer	Provides flash initiation of component under test.
Navy	959 218	Mk 102-1 Stab Primer	Provides flash initiation of component under test.
Army	8 797 250-1	Firing Circuit	Consists of two parts listed below.
	8 797 250-9	Block	Insulated wire subassembly for initiation of electric components
	8 797 250-13	Contact Strip	

MIL-STD-331C
w/CHANGE 1
APPENDIX D

Test Fixtures

Army	81-3-56-G4	Test Holder	
Army	8 797 250-1	Firing Pin Holder	Stab and flash disk tests.
Army	8 797 250-2	Primer Holder	For flash-initiated components.
Army	8 797 250-3	Sleeve	For electric wire-initiated components.
Army	8 797-250-5	Firing Pin	Stab and flash disk tests.
Army	8 797 250-6	Anvil	
Navy	553 333		
Army	8 797 250-7	Bushing	Stab and flash disk tests.
Army	8 797 250-10	Sleeve	
Army	8 797 250-14	Retainer Disc	Electric-initiated disc tests.
Navy	399 475	Firing Pin & Detonator Holder	Nine sizes available for different sized explosive components
	553 331	Firing Pin	
Navy	2 499 436	Output Test Fixture Assy.	Consists of parts listed below. Includes dent block.
	2 496 616	Sleeve	
	2 499 437	Cap	
	2 499 439	Base	
Navy	2 512 817	Functioning & Output Test Fixture Assembly	Consists of parts listed below.
	2 512 825	Firing Pin	
	2 512 826	Firing Pin Holder	
	2 512 827	Primer Holder	
	2 512 828	Detonator Holder	
	2 512 829	Spacer	
	2 512 830	Dent Block	
	2 512 831	Anvil	

TABLE D4-I. Optional Test Equipment (continued)

User	Dwg/Spec	Part	Description
Test Fixtures (continued)			
Navy	2 512 818	Functioning & Output Test Fixture Assembly	Consists of parts listed below.
	2 512 823	Perforation Disc	
	2 512 824	Primer Sleeve	
	2 512 825	Firing Pin	
	2 512 840	Clamp Plate	
	2 512 841	Firing Pin Holder	

MIL-STD-331C
w/CHANGE 1
APPENDIX D

2 512 842	Primer Holder
2 512 843	Anvil
2 512 844	Base
2 512 845	Rod

Confinement Materials

ASTM-D-4549	Polystyrene	Type 1.
ASTM-B121 ASTM-B36 ASTM-B16/16M ASTM-B124	Brass	Half-hard, Composition 22.
SAE-AMS-QQ-A-225 ASTM-B211	Aluminum	T-4 Condition.
ASTM-A-108	Steel	C1018 or C1020.

Adhesive

SAE-AS-8660	Silicone Compound	
None	Tape	Double-stick 0.254 mm (0.001 in) thick

Dent Blocks

Navy	2 499 439	Dent Block	Steel, SAE 1020, cold rolled, Rockwell hardness B70 to B95. 32 mm sq x 16 mm (1 1/4 in sq x 5/8 in) thick. Part of 2 499 436 assembly.
Navy	2 512 830	Dent Block	Aluminum alloy, QQ-A-225/6, Temper T4 or T351, Rockwell hardness B70 to B76. 22 mm sq x 16 mm (7/8 in sq x 5/8 in) thick.

Perforation Disks

Army	8 797 250-4	Lead Disc	QQ-L-201, Grade B.
Army	8 797 250-15	Coined Lead Disc	QQ-L-201, Grade B. Use when explosive component will not perforate disc with a thickness of 3.416±0.254 mm (0.1345±0.0010 in).
Navy	553 332	Lead Disc	Same as 8 797 250-4, except Grade A.
Navy	1 388 809	Lead Disc	Same as 553 332, except 3.0 mm (.120 in) thick instead of 3.4 mm (.1345 in).
Navy	2 512 823	Aluminum Disc	Aluminum alloy, 1100-0. 31 mm (1.216 in) diameter x 3 mm (.125 in) thick. Used with 2 512 818 assembly.

Measurement Devices

Army	8 797 250-8	Plug Gage	Feeler gage for measuring diameter of disc.
	8 797 250-11	Stand	
	8 797 250-12	Screw	

MIL-STD-331C
w/CHANGE 1
APPENDIX D

Navy	1 208 185	Mk 170-1 Test Set	Optically (light) measures size of perforation in disc.
------	-----------	-------------------	---------------------------------------------------------

MIL-STD-331C
w/CHANGE 1
APPENDIX D

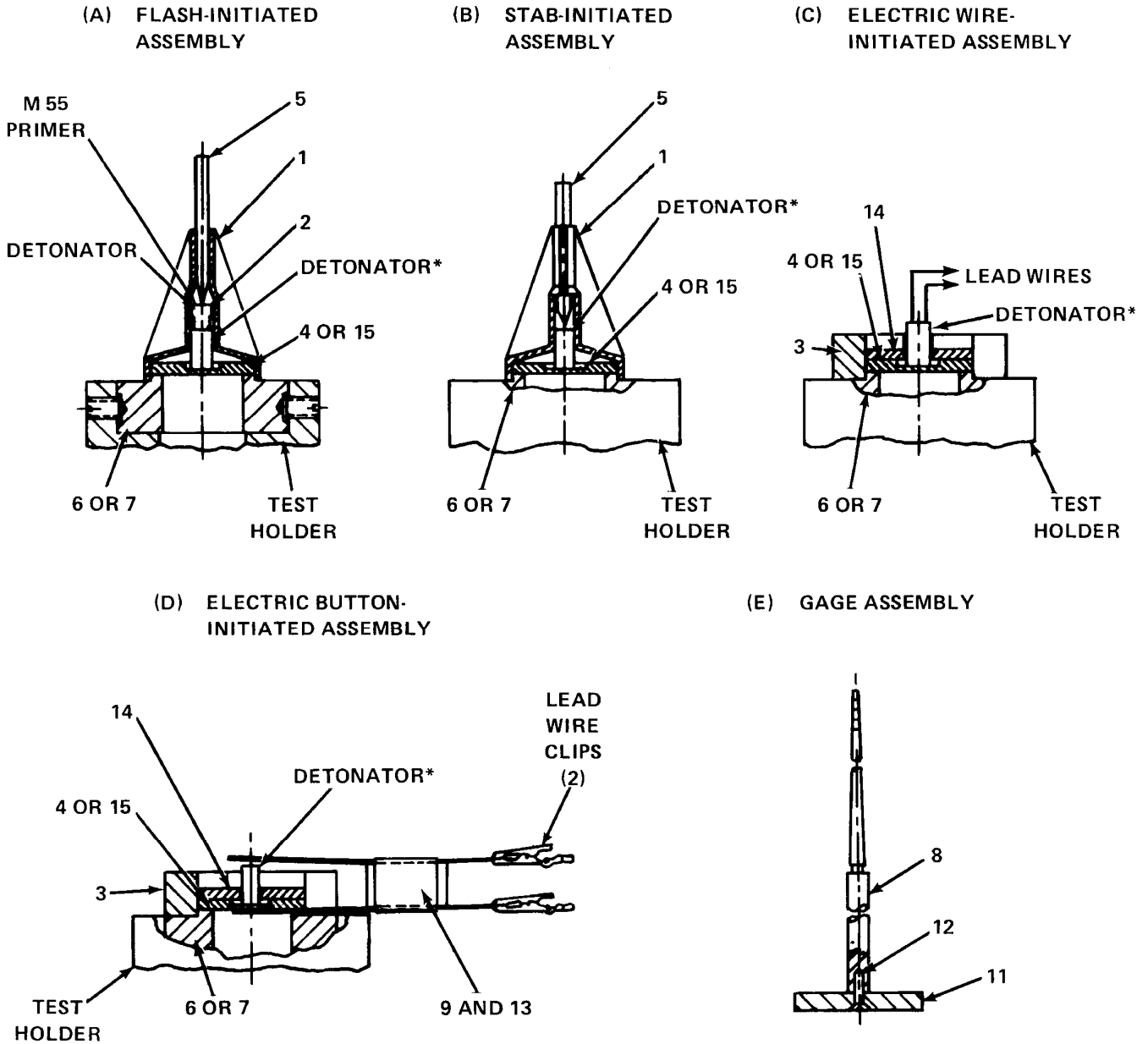

Note: Numbers above indicate part of drawing 8 797 250 and are identified in Table D4-I.

* Use sleeve, drawing 8 797 250-10, as necessary to center detonator.

FIGURE D4-1. Typical Test Fixtures (Army)

MIL-STD-331C
w/CHANGE 1
APPENDIX D

(A) FLASH-INITIATED ARRANGEMENT

NAVY DWG. 2 512 817

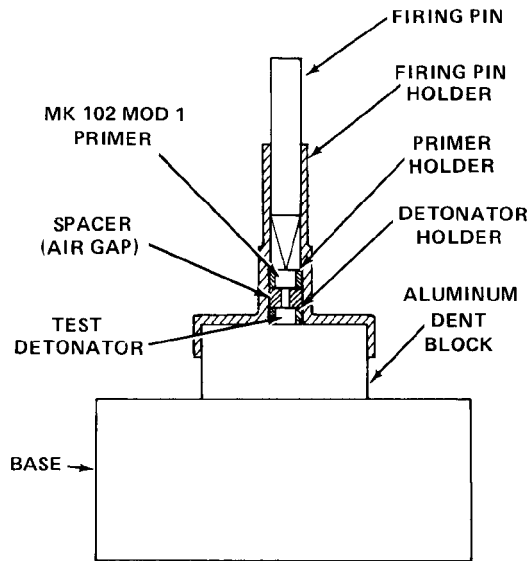

(B) MULTIPLE ELEMENT ARRANGEMENT

NAVY DWG. 2 499 436

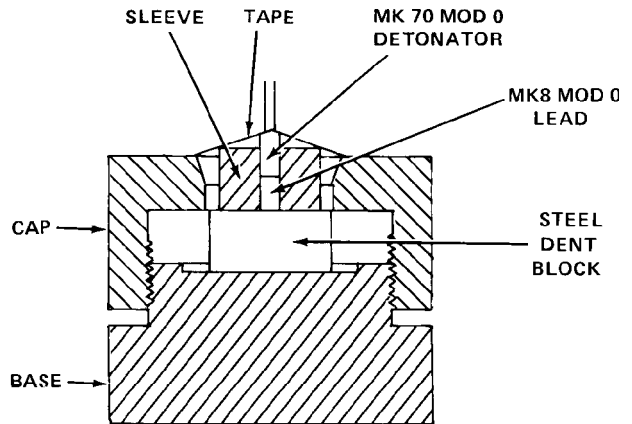

(C) STAB-INITIATED ARRANGEMENT

NAVY DWG. 2 512 818

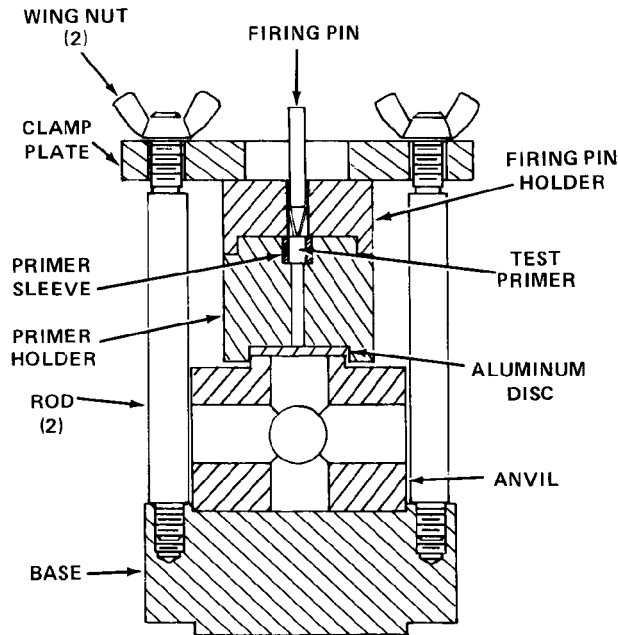

(D) TEST SET MK 170 MOD 1

FOR OPTICAL MEASUREMENT
OF DISC PERFORATION

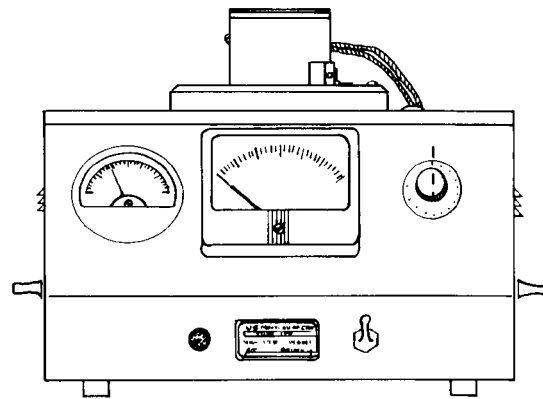

FIGURE D4-2. Typical Test Fixtures (Navy)

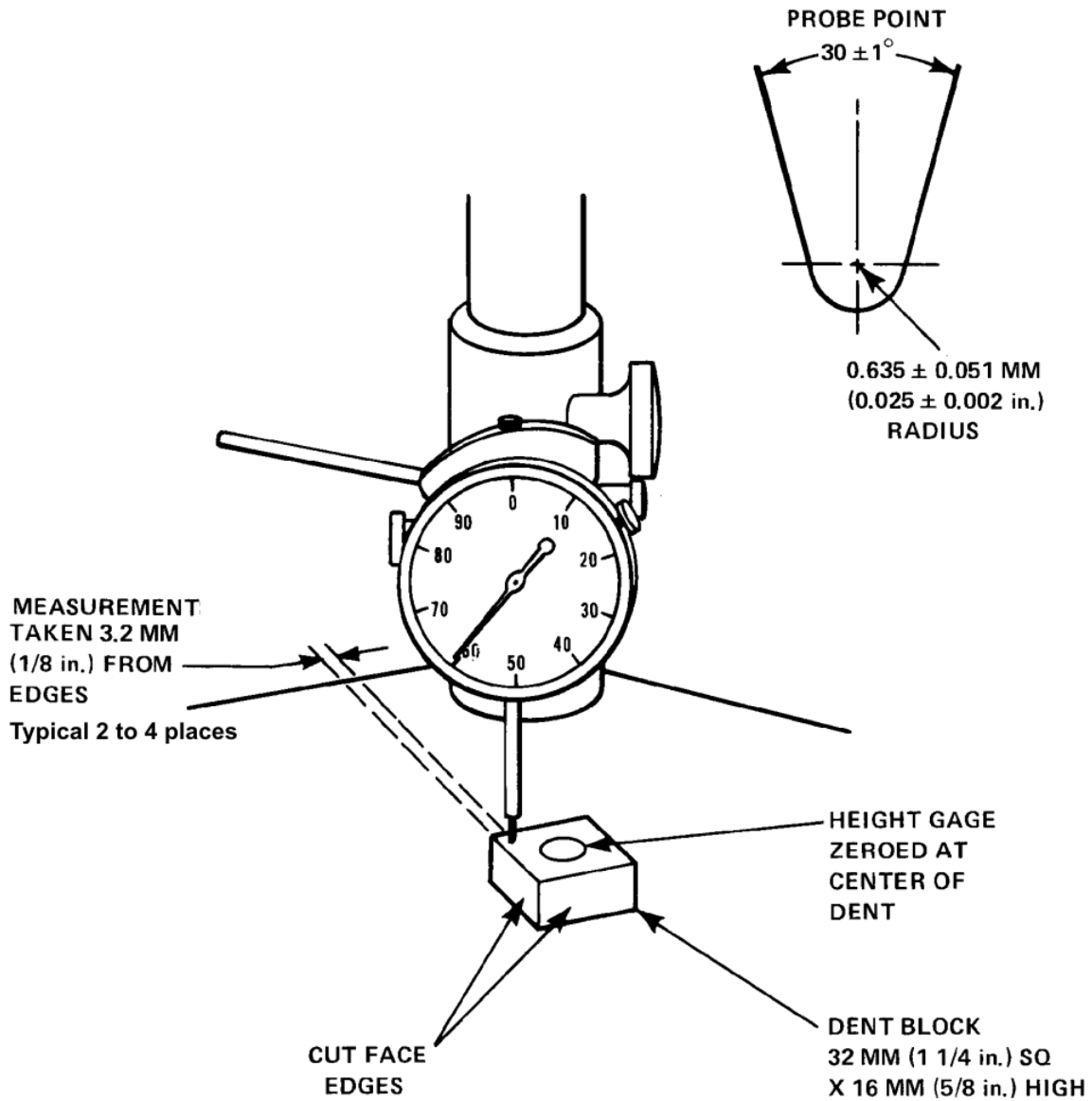

FIGURE D4-3. Depth of Dent Measured with Height Gage

TEST D5

RAIN IMPACT

D5.1. PURPOSE

This is a safety and performance test used during fuze development to demonstrate that the impact sensing element will not function as a result of traversing a specified rain environment and will then function reliably on impact with the test target.

D5.2 DESCRIPTION OF TEST

D5.2.1 General. The test applies to all fuzes with an impact sensing element located in the nose of the fuze.

D5.2.2 Number of fuzes to be tested. The number of fuzes shall be at least the minimum required to demonstrate the specified system safety or reliability at the minimum desired confidence level for this test and shall be stated in the test plan.

D5.2.3 System configuration. The fuze is assembled to a specified munition which is fired from a selected launcher through a simulated rain environment to impact on a target of appropriate material and size.

D5.2.4 Explosive components. The test shall be conducted with the minimum number of explosive components in the fuze and to reduce the risk of damage to the test facility. The fuze booster shall be replaced by an auxiliary spotting charge. The auxiliary charge must be of sufficient size to reliably identify the fuze functioning either in the rain curtain or on the target. Inert munitions shall be used as test vehicles. Whenever possible, the munitions should be vented to allow the spotting charge gasses to exit the munition and minimize munition fragmentation.

D5.2.5 Temperature. The test shall be performed with the fuzed munition at ambient temperature, unless some other temperature is considered more severe with respect to safety or reliability and is specified in the test plan.

D5.2.6 Launcher orientation. The launcher shall be oriented to produce the optimum trajectory through the rain field to minimize changes in the rain drop size distribution.

D5.2.7 Rain field location. For fuzes with arming delays, the distance between the muzzle and the rain environment shall be greater than the arming distance of the fuze. For fuzes without arming delays, the rain field should begin as close to the muzzle as practical and safe.

D5.2.8 Rain field specification. The fuze shall be fired through 305 m (1,000 ft) of simulated rain that has an accumulated rain rate of 711 mm (28 in)/hr as measure by a standard rain gauge and a liquid water content (LWC) of 24.4 grams per cubic meter. The rain rate and LWC tolerance shall be plus or minus 35 percent. The resulting drop size distribution shall conform to Table D5-I.

TABLE D5-I. Drop Size Distribution.

Drop Size Group	Minimum percent of LWC contributed	Maximum percent of LWC contributed
0.0 to 1.0 mm	0	5

MIL-STD-331C
w/CHANGE 1
APPENDIX D

1.1 to 2.0 mm	17	27
2.1 to 3.0 mm	24	44
3.1 to 4.0 mm	18	32
4.1 to 5.0 mm	9	14
5.1 mm and up	2	7

D5.2.9 Target. The target size, material and location shall be specified in the test plan.

D5.2.10 Determination of response. Functional responses will be determined by visual observation, photography, telemetry, a combination of these or any other method determined suitable.

D5.2.11 Test documentation. Test documentation shall conform with 4.8 of the general requirements to this standard. The following specific data shall be recorded for each test:

- a. Launch velocity
- b. recording of the selected measurable rain facility parameters (nozzle exit pressure, water flow rate, and so forth)
- c. pre- or post-test measurement of rain rate or droplet size distribution as a function of the measurable rain facility parameter selected in b., above
- d. wind speed and direction
- e. measured range to an early fuze function
- f. fuze functioning on target
- g. ambient air pressure and temperature.

D5.3. CRITERIA FOR PASSING TEST

A fuze passes the test if it does not function while traversing the simulated rain and then functions as expected on the target located beyond the rain curtain. A fuze fails the test if it either functions while within the simulated rain or it fails to function on the target due to rain-caused damage to the fuze.

D5.4. EQUIPMENT

D5.4.1 Test weapon and munitions. A weapon and inert munitions for which the fuze is standard shall be used. If the fuze is standard for several munitions, weapons, or both, the weapon-munition combination shall be the one that produces the maximum launch velocity and minimum angular velocity (spin) about the munition's longitudinal axis as the munition traverses the rain environment.

D5.4.2 Rain environment. The firing range shall provide a simulated rain environment in the flight path of the munition which meets the requirement of D5.2.8.

D5.4.3 Target. The target size, material and location shall be specified in the test plan.

D5.5. PROCEDURE

D5.5.1 Compliance with operational procedures. The tests shall be performed in accordance with established operational, safety and countdown procedures of the test facility.

D5.5.2 Wind data. Wind measurement instruments will be observed and data recorded.

D5.5.3 Launch velocity. The fuze munition, when fired at the selected temperature, shall use the maximum service charge or an augmented service charge to produce the maximum launch velocity associated with the weapon at maximum operating temperature. Launch velocity shall be measured on five test items to confirm service charge velocity prior to test.

D5.5.4 Projectile trajectory. The test munition shall be fired through the 305 m (1,000 ft) rain curtain specified in D5.2.8 at a quadrant elevation and height to ensure the projectile remains within the rain curtain for the full 305 m (1,000 ft). After passing through the curtain, the munition shall impact the intended target. Location of all fuze functioning shall be recorded, no matter where it occurs, whether on the intended target, behind the target, or as a result of traversing the rain field.

D5.6. ALTERNATE AND OPTIONAL TESTS

D5.6.1 Over test. Tests of intensified severity performed by increasing the munition velocity above the maximum tactical velocity may provide information on the reliability of the fuze impact element in rain. If the functioning velocity can be bracketed, the sensitivity test of Appendix G may provide useful information regarding the confidence level and reliability for any given velocity.

D5.7. RELATED INFORMATION

D5.7.1 Background. The need for this test arises from the fact that functioning of the projectile due to rain impact within and close to the weapon is hazardous to equipment and personnel. In addition, a launched munition loses its combat effectiveness when it detonates prematurely or duds on target impact.

D5.7.2 Rain rate. The rain rate of 711 mm (28 in)/hr was determined experimentally as that rain rate which produced the malfunction rate of the M557 PD Fuze when fired in heavy rain in Vietnam. Additional information on this subject can be found in Technical Report 3966. See D5.7.11.1.

D5.7.3 Rain drop size distribution. The drop size distribution specified in D5.2.8 is based on the Tattelman/Willis Formula described in AFGL-TR-85-0200. See D5.7.11.2.

D5.7.4 Limitation. A test such as this can be a useful development tool, but it can be related only in a general manner to performance in natural rains. It is very impractical, if not impossible, to set up a general field type test that will supply precise information about the conditional functioning probability of the fuze. The information obtained, therefore, is an estimate or an indication of the safety and operability of the fuze when fired through natural rains. Initiation of the fuze may occur only on impact with very large drops. The prediction of the number of drops impacted in any trajectory is statistical.

D5.7.5 Failure modes. As noted in D5.7.4, the failure mode addressed by this test is initiation of the fuze due to a collision with large raindrops. Erosion cannot be evaluated by this technique and the effect of multiple drop collision or cumulative water ingestion effects would be very difficult to compare to a single, long-range firing through rain.

D5.7.6 Sample size. A minimum sample size of 30 fuzes is recommended. Except for the effects of multiple drop collisions and the cumulative effects of water ingestion on a given sample, this is similar to firing one munition along a 9,150 m (30,000 ft) (30 munitions x 305 m (1,000 ft) range) trajectory at essentially maximum velocity through an intense tropical rain or

thundershower. A sample size of 50 or more is preferred to attain a higher confidence in fuze safety and operability.

D5.7.7 Munition trajectory. In an artificial rain field, the height of the rain curtain above the ground is limited and the rain density changes with elevation above the ground. Therefore, the test customer should provide the test facility with a detailed definition of the munition trajectory to ensure the elevation of the munition above ground is known along its 305 m (1,000 ft) path through the simulated rain curtain and to define required test target size.

D5.7.8 Other applications. While the test principally applies to munition fuzes having an impact sensing element situated in the nose of the fuze, it can optionally be used to conduct tests on those items where the impact element is not contained at that location.

D5.7.9 Proximity and time fuzes. The rain sensitivity characteristics of impact sensing elements in proximity and time fuzes can also be tested.

D5.7.10 Rain test facility at Holloman AFB, New Mexico. The test track at Holloman AFB, New Mexico, (commercial telephone (505) 679-2133, DSN 349-2133) operates two rain simulation facilities that generate artificial rain environments in support of erosion and fuze sensitivity testing. One facility is set up along the track to support rain testing by means of rocket sleds. The other facility is a ballistic rain test facility for firing artillery munitions from field weapons through simulated rain. The ballistic rain test facility not only produces rain meeting the conditions described in Section 2, but others as well. The wind restriction for the 711 mm (28 in)/hr rain rate at this facility is 1.5 knots cross range and 5.0 knots down range.

D5.7.11 Bibliography.

D5.7.11.1 *Rain Sensitivity Tests on M557 and M557E1 (XM712E2) Point Detonating Fuzes*, by Eugene M. Ivankoe, Technical Report 3966, U. S. Army Armament Research, Development and Engineering Center, Picatinny Arsenal, New Jersey, 1969.

D5.7.11.2 *Model Vertical Profiles of Extreme Rainfall Rate, Liquid Water Content, and Drop-Size Distribution*, P. Tattleman and P. T. Willis, Technical Report 85-0200, U. S. Air Force Geophysics Laboratory, 1985.

TEST D6

BRUSH IMPACT NO-FIRE TEST

D6.1 PURPOSE

The primary purpose of this test is to verify the performance of an armed anti-armor munition demonstrating it will penetrate light foliage such as brush near a target without functioning and then will function properly upon impact against the fire target. The test procedure and no-fire target simulant can be tailored to test proximity fuzes or guidance sensors for brush insensitivity and by changing the no-fire target's simulant, the test can also be used to assess a munitions performance against specific counter-measures such as camouflage netting.

D6.2 DESCRIPTION

D6.2.1 General. The test applies to all fuzes with an impact sensing element that could be damaged by the passage of the munition through brush or foliage.

D6.2.2 Test quantity. The number of fuzes tested shall be at least the minimum number required to demonstrate the system developer's requirements.

D6.2.3 Temperature. If no environmental conditions are specified in the test plan, the test shall be performed at ambient temperature.

D6.2.4 Intercept conditions. The munition velocity shall be at its maximum expected tactical brush impact velocity. The munition shall intercept the no-fire simulant normal to the plane of the no-fire target then impact the fire target at a typical tactical impact angle (usually not perpendicular to the flight path). No part of the munition should strike or come within 3 ½ inches of the frame supporting the dowels in the no-fire target panels.

D6.2.5 Target. The target consists of two sections, a no-fire dowel target simulating brush, followed by a fire target simulating a hard target.

D6.2.5.1 No-fire dowel target. The no-fire brush simulation target shall be three or more dowel panels, each containing a plane of dowels as shown in the example in figures D6-1 to D6-3. Each panel is made using 8 mm (5/16 inch) diameter hardwood dowels spaced 47 mm (1 7/8 inches) apart forming a flat plane. The panels shall be large enough to assure a high probability that no part of the munition passes within 3.5 inches of the no-fire target frame before the munition is past the point of intended function. Each dowel is mounted in flexible polyurethane form. The panels are attached as shown, out of alignment by 15.7 mm (5/8 inch).

D6.2.5.2 Fire target description. The fire target should represent a likely tactical target surface and impact angle. The fire target must be large enough to assure a high probability that the entire munition fuze sensor impacts on the target surface. The fire target should be mounted behind the no-fire target so that intended fuze function occurs at least five munition diameters behind the no-fire dowel target; a minimum distance of 1.5 meters is recommended (see section D6.6.2) as in the example fire target shown in figure D6-3.

D6.2.5.3 Workmanship. Details of workmanship shall be subject to the inspection and approval of the procuring activity.

D6.2.6 Munition configuration description. The recommended test configuration is a complete munition, however tailoring is acceptable.

- a. Any variations must include the entire fuze system as defined by MIL-STD-1316, including the safety and arming device, the target detection sensor, and signal processing electronics or logic required to either arm the fuzing system or develop a fire signal – whether or not the hardware is located in the portion of the munition titled fuze or safety and arming device.
- b. Additionally all structural elements of the munition shall be included or accurately simulated that can directly or indirectly influence the fuze target detection response.
- c. Only those explosive components that are required to detect fuze function must be used (see D6.3).
- d. For a reverse ballistics test the munition shall be mounted in a manner that prevents any mounting hardware – brackets, etc. – from impacting the no-fire target before the munition impacts the fire target.
- e. The fuze must either fly far enough to arm in the normal manner prior to intercept of the no-fire target or must be armed prior to test.

D6.2.7 Determination of response. The test shall detect both proper fuze and explosive transfer function at the proper standoff distance. Suitable instrumentation shall be used such as high speed photography, video, and telemetry.

D6.2.8 Test documentation. Test plans, performance records, equipment, conditions, results, and analysis shall be documented in accordance with 4.8 of the general requirements to this standard.

D6.2.8.1 Test plan. The test plan shall include: the intended intercept conditions (see D6.2.4), proper fuze function characteristics including standoff distance, a description of the test munition configuration, the means of detecting fuze function, and test objectives. Variations from the test requirements must be reported in the test documentation to assure the intent of the test is being met.

D6.2.8.2 Reported data. Reported data should include as a minimum:

- a. Impact velocity at the no-fire dowel and fire target.
- b. Munition position relative to the fire target when the fuze functioned.
- c. Details for any test failures/anomalies supported by photographic and other direct data records.
- d. The configuration of the no-fire and fire targets including the number of dowel arrays, distance between the arrays and the fire target, angle of the fire target, materials and dimensions.
- e. Temperature at which the test was conducted.
- f. Deviations from the test requirements.

D6.3 CRITERIA FOR PASSING THE TEST

A fuze passes the test if it does not function either before or while penetrating the no-fire target or while in the distance between the no-fire and fire targets, and then functions at the proper standoff distance upon impact with the fire target.

D6.4 EQUIPMENT

D6.4.1 Instrumentation. Instrumentation must record data to satisfy all of the pass-fail criteria and required test report date. The sensing and recording equipment must be capable of discriminating between a munition function on fire target impact that occurs at normal fuze function position or time, and an explosive function that occurs when the explosives impact the fire target.

D6.4.2 Targets. See Figures D6-1 to D6-3 and D6.2.5.

D6.5 TEST PROCEDURE

D6.5.1 Forward ballistics test. The munition is either launched at close range or, guided with sufficient accuracy to ensure impact on the center of the no-fire target matrix. Camera coverage is used to detect the munition velocity and position at impact both horizontally and vertically.

D6.5.2 Reverse ballistics test. With a reverse ballistic test the no-fire target is propelled (usually by a sled) guided to the stationary munition. Both camera and instrumentation of the munition fuze are commonly used to detect fuze function.

D.6.6 RELATED INFORMATION (non mandatory)

D6.6.1 Background.

D6.6.1.1 Historical. Historically the no-fire test required a munition to penetrate 1/8-inch plywood without functioning, often at varied impact angles. This was replaced in some European programs by a dowel test reportedly based on Swiss test data. ARDEC also conducted some dowels tests but to simulate mid-flight cannon projectile brush penetration. Beginning in the 1990's, programs began to use varying alternates to the 1/8-inch plywood test. The purpose of this test is to standardize the procedure and assure comparable munition no-fire performance data for brush insensitivity.

D6.6.1.2 Reasons for a no-fire test. There have been several reasons for no-fire tests that have created confusion in preparing some test plans. The most common misconception is the test is primarily for safety. The reason for this test is described in subparagraph d below, although the test procedure could be tailored to be used for any of the purposes listed below.

- a. Safety – test for fuzing insensitivity from accidental impact on brush within safe separation distance of the gunner. This is an old rationale; modern munitions employ insensitive explosives and design the S&A to prevent inadvertent arming or functioning prior to safe separation; a test on brush is not normally required. For select munitions approved to arm prior to safe separation, failure of a tailored version of this test could have safety implications. If this test procedure is used for such safety purposes, the no-fire target should be reviewed for changes, such as adding a window pane to the brush matrix.
- b. Munition performance – verify the functional performance of the munition after it penetrates brush or other defilade either near the gunner or in mid flight. The purpose is to assure the survival of the seeker or a fuzing sensor. The dowels are a brush simulant that could be used for this purpose.
- c. Lethality after countermeasures – verify fuzing lethality after penetrating known intentional target cover such as camouflage netting, tank skirts, or other planned cover.
- d. Insensitivity to impacting brush near the target. It's common for armored targets to park behind a bush, under a tree, or even place brush on the vehicle. The munition and fuze must penetrate the brush, and then function on the target.

D6.6.2 Characteristics considered in the development of this test/configuration.

The following characteristics were considered in the development of this test:

- a. Brush has the characteristics of twigs – concentrated impact along lines rather than across an area, as plywood would provide. The Europeans reportedly simulated brush by hardwood dowels 8 mm in diameter. While at first this may appear to be large, the

MIL-STD-331C
w/CHANGE 1
APPENDIX D

density of cured wood is lower than living materials which include water. Dowels smaller than 8 mm in diameter are not recommended.

- b. Brush is flexible and can bend when impacted. However the influence of the flexibility will vary; at high speeds flexible objects behave more as a rigid body. The recommended dowel length, and foam mounts are intended to simulate the flexibility of brush for low speed munitions.
- c. Brush has depth; it is not in a single plane. Therefore it is recommended that at least three dowel panels are used for the brush simulant.
- d. Living brush is relatively soft to the touch, compared to dowels. For example, the bark of a twig is softer than the surface of a dowel. The test plan did not consider this significant.
- e. Maintain the insensitivity of munitions to brush similar to older munitions developed using plywood no-fire targets. 1/8-inch hardwood plywood was selected to represent the total mass to penetrate because munitions have been tested against this target for years. It is considered a practical performance requirement based on historical precedence. The test specifies sufficient dowels in three panels to equal the mass of 1/8-inch plywood.
- f. A tactical target could be several meters behind brush, or under forest cover. Munition structural damage caused by the brush impact may not influence fuze performance until the munition has flown some distance. To simulate this it is recommended that the intended fuzing point be located behind the no-fire target by 1.5 meters and not less than five munition diameters to allow structural munition or fuze component vibrations to occur that could influence fuzing or safety and arming.
- g. Typical targets identified in contracts for all-fire testing are 6mm mild steel, and 1" plywood, and these are suggested as practical fire targets. Note the term used in this test is "fire target", not "all-fire target"; the fire target need not be the same as an all-fire target.

D6.6.3 Tailoring. Potential variations from this test include the following areas:

- a. Warhead: Testing with a tactical warhead is desirable, however, it is only important to know if the fuze functions normally. The explosives can be limited to the booster; a spotting charge or even no explosives can be substituted as long as fuze explosive function is accurately sensed.
- b. Fuze function detection: To prevent controversy whether the munition impacted the brush simulant framing or experienced other test errors, high speed motion photographic camera coverage is recommended recording the X and Y plane of the target. If an explosive event is used to indicate fuze function, one high speed camera using mirrors to provide both X and Y plane viewing can be sufficient to record munition velocity and explosive event timing.
- c. Combined no-fire & all-fire test: It's tempting to combine the fuzing no-fire and all-fire test. The all-fire test usually requires a greater quantity of tests than a no-fire test to examine varying impact angles and at the lowest expected intercept velocities. The no-fire test on the other hand should be performed at the highest expected impact velocities and can be performed with only one impact angle.

MIL-STD-331C
w/CHANGE 1
APPENDIX D

- d. Camouflage netting test: By substituting system specific camouflage netting for the defined dowel arrays, the test procedure can be used to acceptably test munitions capability to penetrate camouflage and still function acceptably on the target.
- e. Flexible brush can behave as a rigid body with high speed munitions. This simplifies the simulant allowing rigid short dowels without foam mounts to be substituted for the specified long dowels. Munition impact on the dowels still should be at least 1.5 inches from the no-fire target frame, however.

D6.6.4 Reverse ballistics test.

- a. An example reverse ballistics no-fire target for a seven inch diameter munition that flies at a velocity exceeding Mach one, is a long hollow plastic tube about 12 inches inside diameter with dowels mounted inside the tube positioned as they would be in the normal no-fire target. A rolled homogeneous armor, RHA, target is also inside the tube at a shallow angle to the axis of the tube 1.5 meters distance behind the dowel matrix. The munition simulant is cantilever mounted to allow the munition to impact the fuzing sensor before the no-fire target tube impacted the munition mounting structure.
- b. Less than a complete munition with simulations for some of the munition is acceptable in a reverse ballistics test as long as munition fuze critical features are present including consideration of any munition electrical or structural features that could either dud or create an unintended fuze function – such as secondary structural damage from damage to fins or wings.

MIL-STD-331C
w/CHANGE 1
APPENDIX D

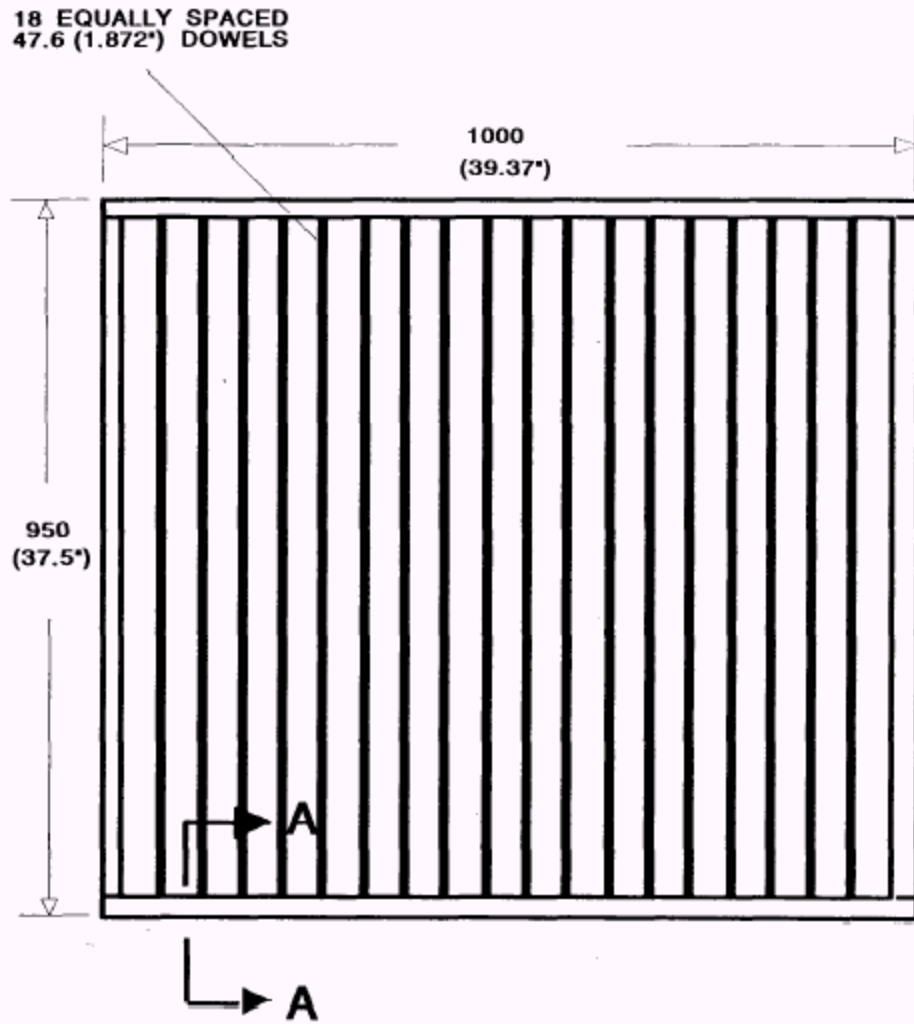

NOTE: ALL DIMENSIONS ARE IN MILLIMETERS (INCH)

FIGURE D6-1 Dowel Panel

MIL-STD-331C
w/CHANGE 1
APPENDIX D

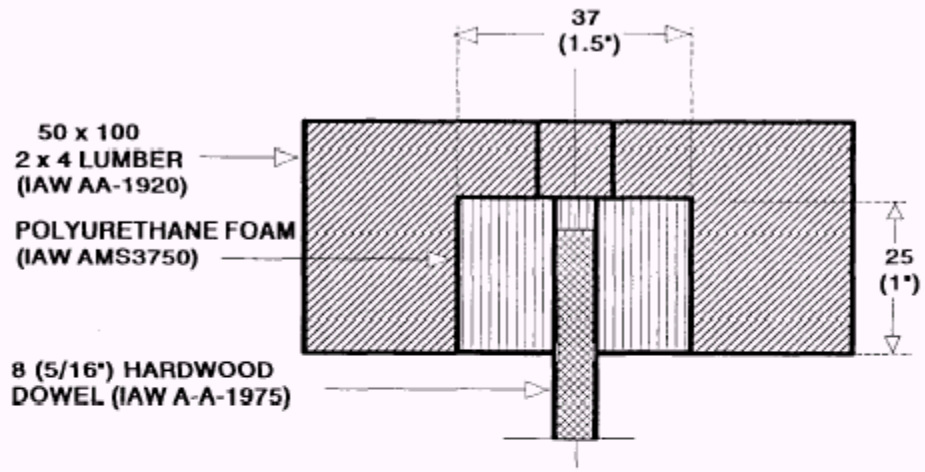

NOTE: ALL DIMENSIONS ARE IN MILLIMETERS (INCH)

Figure D6-2 Section A-A

MIL-STD-331C
w/CHANGE 1
APPENDIX D

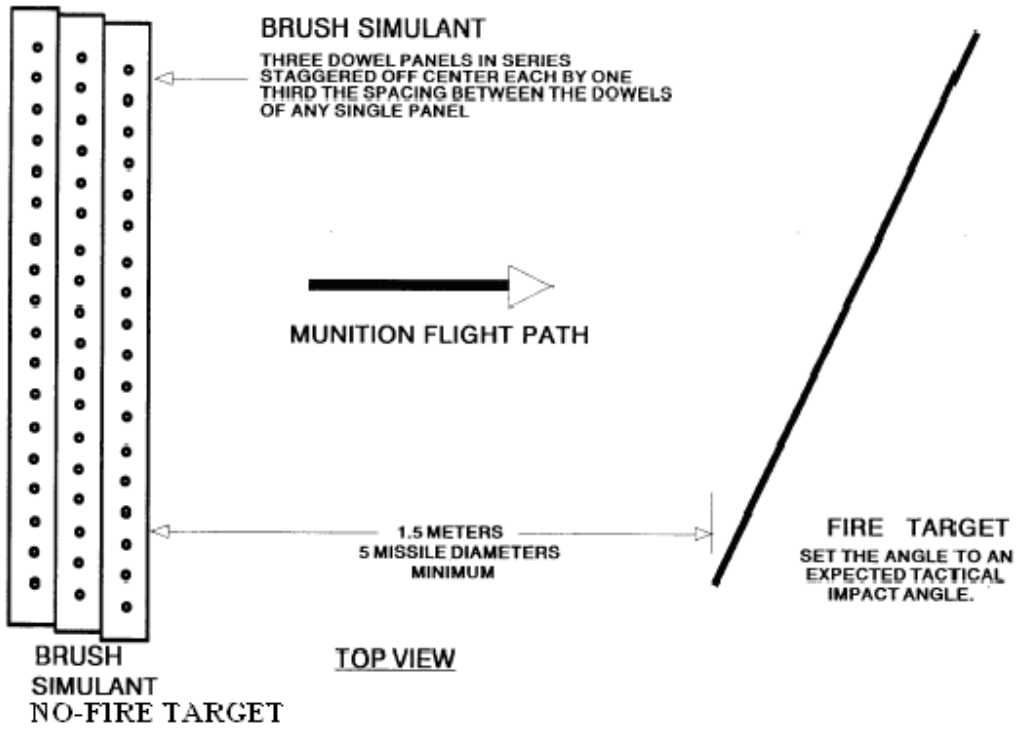

FIGURE D6-3. NO-FIRE AND FIRE TARGETS

MIL-STD-331C
w/CHANGE 1
APPENDIX D
TEST D7

MORTAR AMMUNITION FUZE DOUBLE LOADING TEST

D7.1 PURPOSE

This is a field safety test used to determine, in the event of double loading, whether the contour of the ogive of the projectile fuze can initiate the round dropped on it. A second objective is to determine if the bottom fuze can be initiated by the impact of the second round. In addition, a third test is used to determine if the fuze under test is susceptible to initiation by hot propellant gases. This test is distinct from the mortar double loading test which is used to determine barrel strength or the potential of the high explosive filling of the rounds contributing to effects of an incident. This test is a fuze-oriented test, and is distinct from mortar double loading tests found in other test documents (e.g. STANAG 4225).

D7.2 DESCRIPTION

D7.2.1 General. The fuzes shall be mounted to inert projectiles, with live fuzes set to function in the point detonating, superquick, or equivalent setting. Proximity or time settings should not be used for this test. Cartridges with tactical primers and propellant will be used during the test as outlined below. This test consists of double loading a mortar tube under varying conditions to establish that the fuze does not contribute to pre-ignition of the propellant or to a high order detonation. In addition, the test determines whether the contour of the fuze nose can initiate a double loaded cartridge.

D7.2.2 Fuze configuration. Fuzes should be in the tactical configuration, and all explosive elements shall be in the fuze during the test. Inert fuzes shall conform to the external configuration of the live fuzes undergoing testing, and shall be ready to fire.

D7.2.3 Applicable publications. All standards, specifications, drawings, procedures, and manuals that form a part of this test are listed in Section 2 of the introduction to this standard.

D7.2.4 Test documentation. Test plans, performance records, equipment, conditions, results, and analysis shall be documented in accordance with Section 4.8 of the general requirements to this standard. Test plans shall include requirements for tube wear, elevation angle, temperature conditioning for the cartridge and fuze, and so forth, as required.

In addition, specification of round components (tube, propelling charge, primer, projectile, and fuze) in the configuration specified by the test procedure shall be documented.

D7.3 CRITERIA FOR PASSING TEST

D7.3.1 the criteria for passing the test shall be that, as outlined in section D7.5 of this test:

- a. The primer of the second cartridge shall not be initiated by the nose of the fuze it impacts against.
- b. The fuze of the bottom cartridge is not initiated by impacting the second cartridge.
- c. The fuze is not susceptible to initiation of its explosive components by the action of hot propellant gases, while the fuze is still in the barrel.
- d. There is no structural failure of the fuze in such a manner as to expose the high explosive filling of the cartridge to hot propellant gases.

D7.3.2 The fuze under test must be safe to handle and to dispose of following this test and no initiation of the fuze explosive train beyond the interrupter and booster shall have occurred. In order to determine if this criteria is met, there shall be no detonation, deformation, burning, charring, scorching, or melting of the fuze explosive elements beyond the interrupter for the fuze under test.

D.7.4 Equipment

D7.4.1 Barrel. A mortar barrel appropriate for the fuzed projectiles and in accordance with the stage of wear specified in the test directive. It should be noted that ostensibly, barrel wear should not have any influence in the outcome of this test. The barrel should be capable of being loaded remotely in order to drop an inert projectile with a live fuze into it. The test weapon shall be properly barricaded to confine any possible fragmentation for subsequent analysis, and to protect test operators and observers. Barrels used for this test will be within the maximum permissible inner diameter allowed for that system. The barrel should be monitored to obtain time traces of temperature, pressure, etc., from both the base end of the tube and forward of the first projectile, to determine if conditions behind and between the cartridges can contribute to or be the cause of a failure.

D7.4.2 Projectile. Inert filled mortar projectiles should be used which are assembled in accordance with the technical specification. Projectiles are to be fitted with live, tactical fuzes. The inert charges inside the projectiles must simulate the weight, density, and mechanical properties of the explosives they replace. It is essential that the locking torque of the screwed assemblies and the seals be to specification. No round or fuze should be subjected to more than one test. The projectiles should be capable of being remotely loaded into the test barrel. No charges should be used for conducting this test.

D7.4.3 Instrumentation. No special instrumentation is required for this test, unless specified in the test directive. Photographic or other equipment capable of determining fuze function and propellant ignition may be used.

D7.4.4 Temperature conditioning equipment. As required by the test directive.

D7.4.5 No round or fuze shall be subjected to more than one test.

D7.5 PROCEDURE

D7.5.1 Procedure Number 1: The contour of fuze on Round No. 1 will not ignite primer or propellant charge of Round No. 2.

D7.5.1.1 Round No. 1 is inserted into the bottom of the tube, which is set at an elevation specified by the test directive. Round No. 1 shall consist of all inert components (primer, propellant charge, projectile and fuze). Round No. 2 will be inert except for the primer and propellant charge. The propellant shall be at maximum charge.

D7.5.1.2 Round No. 2 is suspended at the muzzle utilizing a mechanism allowing for the remote release of the round. Round No. 2 is released and allowed to slide down the barrel and impinge on the inert fuze of Round No. 1.

D7.5.1.3 If Round No.2 is ejected from the barrel, then the fuze of Round No. 1 has ignited the round, and has failed the criteria of the test. If there is no ejection, allow fifteen minutes before removing rounds and inspect to determine if the criteria of paragraph 3 have been met.

D7.5.2 Procedure Number 2: The fuze on Round No. 1 will not ignite primer or propellant charge of Round No. 2, by ramming at mortar barrel muzzle. This test simulates a double loading condition where the first round has been dropped down the barrel, but is not immediately fired. Due to cook-off or other phenomena, it is fired at the time a second round is dropped down the barrel.

D7.5.2.1 Round No. 1 is inserted into the bottom of the tube, which is set at an elevation specified by the test directive. For this test, use a triggered-fired barrel or equivalent. Round No. 1 shall consist of a live primer and fuze, with an inert projectile. The propellant shall be at maximum

MIL-STD-331C
w/CHANGE 1
APPENDIX D

charge. The fuze shall be set in the point detonating, super quick, or equivalent setting. Proximity or time settings should not be used for this test. Round No. 2 will be all inert except for the primer and propellant charge. The propellant shall be at maximum charge.

D7.5.2.2 Round No. 2 is suspended at or near the muzzle of the barrel. Round No. 1 is then remotely initiated so that the fuze of Round No. 1 impacts on the primer of Round No. 2 at or near the muzzle.

D7.5.2.3 Both rounds are recovered. Round No. 2 is inspected for any evidence of ignition of the primer and/or propellant. Round No. 1 is inspected for evidence that the fuze explosive elements have been initiated or the fuze structurally damaged.

D7.5.3 Procedure Number 3: The explosive components of the fuze on Round No. 1 will not be initiated by the action of hot gases as a result of ignition of the propellant and primer of either or both rounds. This test simulates a double loading condition where the first round has been dropped down the barrel, but is not immediately fired. The second round also sticks in the barrel. Due to cook-off or other phenomena, one or both rounds then ignite, and it is desired that the bottom fuze explosive train will not be initiated to cause a high order functioning of the projectile in the barrel.

D7.5.3.1 Round No. 1 is inserted into the bottom of the tube, which is set at an elevation specified by the test directive. For this test, use a triggered-fired barrel or equivalent. Round No. 1 shall consist of an inert projectile, inert primer and propellant, and a live, unarmed fuze. The fuze shall be set in the point detonating, superquick, or equivalent setting. Proximity or time settings should not be used for this test. Round No. 2 shall consist of an inert fuze, inert projectile, and live primer with a device to initiate the primer remotely. The propellant shall be at maximum charge.

D7.5.3.2 The fuze on Round No. 1 must be in the ready to fire mode (i.e. remove any pull wires or pins). Round No. 2 is placed in the barrel, and in contact with Round No. 1. Round No. 2 is then remotely initiated.

D7.5.3.3 Both round are recovered. The fuze of Round No. 1 is inspected to assure that all explosive elements beyond the interrupter meet the criteria of paragraph 3.2, and that there is no indication of hot propellant gases reaching the high explosive cavity of the projectile through the fuze or fuze well.

D7.5.3.4 In a second iteration of this test, repeat the procedures of D7.5.3.1 through D7.5.3.3, with both rounds having live primers and propellants.

D7.5.4 Temperature conditioning. Perform the test with the fuzes and projectiles and other components at ambient temperature, unless otherwise specified in the test directive.

D7.5.5 Elevation angle. Adjust the barrel's quadrant elevation angle to that value specified in the test directive. If none is specified, perform the test at the maximum angle allowed by the weapon system.

D7.6 ALTERNATE AND OPTIONAL TESTS

None.

D7.7 RELATED INFORMATION

D7.7.1 Information for NATO users. NATO users should review Annex E of STANAG 4225 "The Safety Evaluation of Mortar Bombs", which gives details of a non-mandatory double loading test. Consideration should be given to supplying details of the results of this double loading test, for information, to any potential user of STANAG 4225.

TEST D8
PROGRESSIVE ARMING TEST

D8.1 PURPOSE

This is a laboratory test to determine the correlation between the position of the explosive train interrupter and the probability of explosive transfer. It is a means to determine the interrupter position at which the fuze is armed for the purpose of safety assessment, and it can be used, in some cases, to predict the numerical effectiveness of the interrupter at other positions.

D8.2 DESCRIPTION

D8.2.1 General. The test consists of repeated firings of the initiator with the explosive train interrupter, or out-of-line element, incrementally located either closer to, or further from, the armed position. The goal is to determine the point at which the sensitive elements will transfer the detonation to the next explosive element(s) in the train. The chosen test strategy and results shall be presented and justified to the appropriate service safety authority.

D8.2.2 Test item configuration. The explosive train of the fuzes shall be completely assembled. If the booster charge is not the next explosive element after the interrupter, it may be omitted if considered to be unsafe to test in a laboratory environment. Fuzes may require modification to locate and hold the interrupter in progressively incremental positions of arming, but care should be taken to preserve, as nearly as practical, the same confinement and structural integrity for the expanding gases. Each test item, including explosive components, shall be subjected to the test conditions and tested only once. Recycling of any of the explosive components for the testing is not permitted.

D8.2.3 Interrupter positions. Test positions shall be defined by an appropriate parameter that is varied from test-to-test. Usually this parameter will be the shortest distance between the sensitive element and the next explosive element, measured from edge-to-edge or center-to-center. This parameter is reported as the out-of-line distance. The parameter shall be varied following one of the statistical methods of Appendix G.

D8.2.4 Interpretation of results. There will only be two test outcomes: "transfer" and "non-transfer".

D8.2.4.1 Detonation train. For a detonation train, transfer is defined as having occurred when there is detonation transfer to an explosive component after the explosive train interrupter as evidenced by a dent in the witness plate. Non-transfer is defined as having occurred when there is no dent in the witness plate. Any charring, scorching, melting, perforation, or deformation of any explosive component after the explosive train interrupter will be reported for information purposes only, but will not be considered as a "transfer".

D8.2.4.2 Pyrotechnic train. For a pyrotechnic train, transfer is defined as having occurred when there is any reactive consumption in any pyrotechnic element after the interrupter. Non-transfer is defined as having occurred when there is no consumption. Any charring, scorching, melting, perforation, or deformation of any component after the interrupter will not be considered as a "transfer".

D8.2.5 Interpretation of results. DELETED.

D8.2.6 Applicable publications. All standards, specifications, drawings, procedures and manuals that form a part of this test are listed in Section 2 of the introduction to this standard.

D8.2.7 Test documentation. Test plans, performance records, equipment, test conditions, test results, and analysis shall be documented in accordance with Section 4.8 of the general requirements to this standard.

D8.3 INFORMATION TO BE DETERMINED

D8.3.1 Armed Position. The Armed position, identified per MIL-STD-1316 to be the point at which the probability of propagation (i.e. transfer) of detonation to an explosive component(s) on the barrier side opposite that of the sensitive explosive component(s) equals .005, at a confidence level of 95%, will be determined from this test. The upper single-sided confidence level shall be used.

D8.3.2 Effectiveness of the interrupter. The probability of propagation in the full out-of-line position may be calculated from the data. Caution should be taken to be sure that the extrapolation of the data is valid. A change in geometry of the explosive interface should be cause for examination of the validity of the extrapolation.

D8.4 EQUIPMENT

D8.4.1 Test fixture. Any fixture that may be required to hold/restrain the test item shall not influence the test results.

D8.4.2 Firing mechanism. Initiation of the test fuze shall be performed by means to replicate as closely as possible, the ignition stimulus seen by the sensitive component in actual use. Further, confinement effects on all explosive components must be kept as close as possible to those which normally exist in the fuze.

D8.4.3 Interrupter position. An appropriate means to fix the interrupter, at positions required by the selected test methodology with the necessary accuracy, is required. Care must be taken to preserve the fuze configuration.

D8.5 PROCEDURE

D8.5.1 Test methodology. A method (test and subsequent analysis) that will furnish statistically significant results for the design configuration shall be used. Refer to Appendix G, Analytical Methods to Determine the Reliability of One-Shot Devices.

D8.5.2 Test conditions. There is no specific requirement for the pre-test conditioning of the fuze samples and the testing conditions. However, the temperature and other pertinent environmental conditioning of the samples before and during the testing shall be recorded.

D8.6 RELATED INFORMATION

D8.6.1 Assumptions. Generally it is assumed that the probability of initiating the out-of-line component can be expressed as a function of the distance between the two explosive components, and the function is continuous and smoothly decreasing throughout the range of separation from the "in-line" position to the "out-of-line" position. Then ordinary methods of analysis apply. There may occur situations where the probability function is not smoothly decreasing because of peculiarities in design. When this situation occurs, case specific special analysis may be needed to guarantee that the data to be determined (section 3) meet the required confidence level.

MIL-STD-331C
w/CHANGE 1
APPENDIX E

APPENDIX E
AIRCRAFT MUNITION TESTS

TEST E1

JETTISON

E1.1. PURPOSE

This is a field safety test for fuzes with flight-selectable safe jettison capability. When jettisoned safe, the fuze must not contribute to high-order detonation of the warhead on earth or water impact.

E1.2. DESCRIPTION

E1.2.1 General. This test applies to air launched bombs, rockets or missiles having a flight-selectable safe jettison option. It excludes munitions such as rail-launched missiles or rockets fired from tubes, but includes systems which can be safely jettisoned by free-fall release of weapon pods. This test provides an air drop method and an optional simulation using a ground launcher. The desired method shall be stated in the test plan. The fuze is assembled to the explosive-loaded munition and dropped or launched against the target. The release altitude or acceleration provided by the ground launcher system shall be great enough to ensure that the munition reaches terminal velocity before impact. Terminal velocity is the constant velocity of a falling body attained when the resistance of air is equal to the force of gravity acting on the body. The impact is observed and recorded.

E1.2.1.1 Air drop method. The fuzed munition is loaded on the aircraft, all other components in the fuzing system are installed or connected in the normal manner and the aircraft arming system is set for safe (unarmed) release. The munition is dropped against a target of normal soil or water, as specified by the test plan.

E1.2.1.2 Ground launcher method. The fuzed munition is loaded on a ground launcher system capable of accelerating it to a speed simulating terminal velocity. The munition is propelled along the launcher and allowed to impact a sand-filled bin.

E1.2.2 Applicable publications. All standards, specifications, drawings, procedures and manuals which form a part of this test are listed in Section 2 of the introduction to this standard.

E1.2.3 Test documentation. Test plans, performance records, equipment, conditions, results, and analysis shall be documented in accordance with 4.8 of the general requirements to this standard.

E1.3. CRITERIA FOR PASSING TEST

E1.3.1 Warhead function. There shall be no warhead function attributable to the fuze.

E1.3.2 Fuze condition. At the completion of this test, the fuze shall be safe for disposal in accordance with Paragraph 4.6.2.1b of the general requirements to this standard.

E1.3.3 Decision basis. Absence of a warhead function signifies that the fuze has passed this test. Where test data are inconclusive, breakdown, inspection, other appropriate tests and engineering judgment shall form the basis for the decision that fuzes have passed or failed the test.

E1.4. EQUIPMENT

E1.4.1 Launch platform. A suitable aircraft or ground launcher simulating the jettison shall be used.

E1.4.1.1 Aircraft. The aircraft shall be one of the type which would normally be used to launch the munition in service use. It must be equipped with a fire control system sufficiently

MIL-STD-331C
w/CHANGE 1
APPENDIX E

accurate to provide impacts within the areas covered by surface instrumentation.

E1.4.1.2 Ground launcher. The ground launcher and associated accelerator rocket motor must be capable of accelerating the munition to the specified impact velocity. The acceleration force must be minimized so that the fuze is not adversely influenced in the simulation. The accelerator must separate from the munition before impact, and must not contact the munition again. This may require deflector plates or retro rockets.

E1.4.2 Scavenger fuze. In performing jettison tests with munitions that can accommodate two fuzes, and which are not to be recovered, a second scavenger fuze may be used to dispose of the ordnance. Although the use of a scavenger fuze could jeopardize test results, it is permissible provided the following conditions are satisfied: a. the scavenger fuze will not be destroyed on impact; b. its minimum functioning time is sufficiently long so that detonation of the scavenger fuze may be distinguished from possible detonation of the fuze being tested; and c. it will not produce a premature explosion.

E1.4.3 Target area. Soil or water targets shall be specified in the test plan for jettison from aircraft. A sand-filled bin is used for ground launcher simulations.

E1.4.3.1 Soil. Any land surface that is not marshy, does not contain a large proportion of rock, has not been artificially packed or hardened, or is suitable for cultivation including desert areas which could be cultivated if properly irrigated.

E1.4.3.2 Water. Not less than 6 m (20 ft) deep.

E1.4.3.3 Sand. A sand-filled bin with a vertical entrance face made of nominal 2 in lumber. The entrance face is a plane normal to the line of fire. The cross section of the bin normal to the line of fire must be large enough to contain the missile. The minimum length shall be 125% of the maximum expected penetration distance. The bin shall be located so it can be adequately photographed.

E1.4.4 Instrumentation and recording devices. Appropriate recording equipment and range instrumentation shall be specified in the test plan.

E1.4.4.1 Video recording. There shall be video recording of the impact area. Exposure rate shall not be less than 64 frames/second.

E1.4.4.2 Geophone. Geophone or other microphonic equipment coupled with suitable recorders may be specified in the test directive to obtain additional evidence of detonation, particularly when delay fuzing is involved in the test.

E1.4.4.3 Range instrumentation. Suitable range instrumentation specified by the test directive may include velocity and acceleration measuring equipment, position trackers, on-board sensors and telemetry, and the digital or analog recording devices associated with each instrument.

E1.4.5 Recovery facilities. Facilities for recovery and examination of the munition may be required when other evidence is inconclusive.

E1.5. PROCEDURE

E1.5.1 General. The test shall be conducted at ambient temperature using an explosive-loaded warhead intended for the test fuze. The fuze service configuration shall be duplicated including all explosive components and accessories normally associated with it.

E1.5.2 Scavenger fuze installation. Install a scavenger fuze system if required by the test directive.

E1.5.3 Rocket or missile motors. For the ground launcher method, test munition rocket or missile motors shall be inert to avoid confusion which may arise due to motor blow-up on impact.

MIL-STD-331C
w/CHANGE 1
APPENDIX E

E1.5.4 Instrumentation. Operate the test instrumentation in accordance with the test plan. Photographic, sound, or other recordings shall be made of the impact beginning shortly before impact and continuing past the longest fuze delay time.

E1.5.5 Aircraft jettison. Drop the ordnance in the condition in which it normally would be safely jettisoned in flight so as to strike in the impact area. Jettison altitude shall be sufficient to approximate terminal velocity at impact.

E1.5.6 Ground launch. Launch the munition to ensure it will impact at approximately terminal velocity. Measure the velocity immediately before impact.

E1.5.7 Compliance. Analyze the test results and determine whether or not the test article meets the pass/fail criteria in E1.3. In case of instrument failure or conflicting evidence, recover and examine the munition, or repeat the test. Observe and record deformation of the fuze, any functioning of the fuze, and degree of arming, if any.

E1.6. ALTERNATE AND OPTIONAL TESTS

None.

E1.7. RELATED INFORMATION

E1.7.1 Need. The need for a jettison test arises from the possible necessity for releasing munitions over friendly territory in case of an accident to the aircraft or munition, cancellation of the mission or the need to jettison weight. In each case, an explosion could result in death or injury to friendly ground forces or the flight crew and serious damage to the aircraft or ground installations and equipment.

E1.7.2 Launch platform. The procedures in this test are performed with either an aircraft or ground launcher. The use of a ground launcher to simulate the air-jettison or separation has advantages of better impact containment, better instrumentation, all-weather firing, and reproducibility of test conditions. Restrictions include prohibition of testing fuzes which could arm or be otherwise adversely influenced by launcher acceleration forces.

TEST E2

LOW-ALTITUDE ACCIDENTAL RELEASE

E2.1. PURPOSE

This is a field safety test simulating accidental release of airborne munitions on takeoff or landing. The fuze must not contribute to high-order detonation when the munition impacts a hard surface.

E2.2. DESCRIPTION

E2.2.1 General. A malfunction of an aircraft or its release equipment occurring during take-off or landing could accidentally release munitions. This test is designed to determine the effect of such occurrences on the fuze. An inert munition equipped with a live fuze and inert booster is dropped from a low-flying aircraft onto a hard surface. The fuze is released safe or prevented from arming by the service safety feature.

E2.2.2 Applicable publications. All standards, specifications, drawings, procedures and manuals which form a part of this test are listed in Section 2 of the introduction to this standard.

E2.2.3 Test documentation. Test plans, performance records, equipment, conditions, results, and analysis shall be documented in accordance with 4.8 of the general requirements to this standard.

E2.3. CRITERIA FOR PASSING TEST

E2.3.1 Weapon function. There shall be no warhead function attributable to the fuze.

E2.3.2 Fuze condition. At the completion of this test, the fuze shall be safe for disposal in accordance with 4.6.2.1b of the general requirements to this standard.

E2.3.3 Decision basis. Breakdown, inspection, other appropriate tests and engineering judgment shall form the basis for the decision that fuzes have passed or failed the test.

E2.4. EQUIPMENT

E2.4.1 Aircraft. Use an aircraft having the necessary equipment for carrying and dropping the munition.

E2.4.2 Target. Use a suitable hard surface area to simulate a runway.

E2.4.3 Recovery facilities. If the condition of the fuze cannot be determined without its removal from the munition, special equipment will be necessary to remove the fuze with safety.

E2.5. PROCEDURE

E2.5.1 Temperature. Perform the test with munition at ambient temperature.

E2.5.2 Assembly. Assemble the fuze with all of its explosive components for proper functioning, less booster, to the inert munition of the type with which it is intended to be used. Ensure a safe release to every extent possible by selecting optimum fuze settings and control of

the munition and aircraft interface.

E2.5.3 Launch. Drop the fuzed munition onto a hard surface from an aircraft flying at an altitude of 61 m (200 ft), at 370 km/hr (200 knots) true airspeed. The minimum release altitude shall be sufficient to prevent damage to the aircraft in the event of munition ricochet.

E2.5.4 Recovery. Recover the munition after impact. Observe and record deformation of the fuze, any functioning of the fuze, and degree of arming, if any.

E2.5.5 Compliance. Analyze the test results and determine whether or not the test article meets the pass/fail criteria in E2.3. Continue testing the specified number of items.

E2.6. ALTERNATE AND OPTIONAL TESTS

None.

E2.7. RELATED INFORMATION

None.

TEST E3

ARRESTED LANDING MUNITION PULL-OFF

E3.1. PURPOSE

This is a field safety test simulating accidental release of an airborne weapon upon arrested landing aboard an aircraft carrier. The fuze must not contribute to high-order detonation on munition impact.

E3.2. DESCRIPTION OF TEST

E3.2.1 General. The safety of personnel and equipment aboard an aircraft carrier requires that a munition which comes loose from an aircraft during an arrested landing resist detonation and deflagration on impact with the deck or bulkhead. An inert munition equipped with a live fuze and inert booster is propelled from a ground launcher with the fuze in the unarmed condition, just as it would be if carried on an aircraft. After leaving the launcher, the test munition impacts a horizontal steel deck simulating the flight deck of an aircraft carrier. See Figure E3-1. At 12 to 18 m (40 to 60 ft) beyond the initial point of impact on the deck, the test munition impacts a vertical steel target normal to the line of flight. This test applies to all externally-mounted, aircraft-launched bomb, rocket and guided missile fuzes which are not adversely affected by acceleration force applied during the simulation.

E3.2.2 Applicable publications. All standards, specifications, drawings, procedures and manuals which form a part of this test are listed in Section 2 of the introduction to this standard.

E3.2.3 Test documentation. Test plans, performance records, equipment, conditions, results, and analysis shall be documented in accordance with 4.8 of the general requirements to this standard.

E3.3. CRITERIA FOR PASSING TEST

E3.3.1 Warhead function. There shall be no warhead function attributable to the fuze.

E3.3.2 Fuze condition. At the completion of this test, the fuze shall be safe for disposal in accordance with 4.6.2.1b of the general requirements to this standard.

E3.3.3 Decision basis. Breakdown, inspection, other appropriate tests and engineering judgment shall form the basis for the decision that fuzes have passed or failed the test.

E3.4. EQUIPMENT

E3.4.1 Ground launcher. Use a ground launcher of sufficient length to permit the munition to obtain a striking velocity of approximately 45.7 m/s (150 ft/s) on the deck. See Figure E3-1.

E3.4.2 Rocket motor. Use a rocket motor or other suitable means capable of boosting the test munition to the required velocity for impact. If a separate booster motor is used, it should be separated from the munition being propelled before impact and should not again contact the munition. This may entail the use of retro-rockets or some means of deflecting the booster motor as it leaves the launcher.

E3.4.3 Target. Use an appropriate deck and vertical bulkhead. Refer to Figure E3-1. The

MIL-STD-331C
w/CHANGE 1
APPENDIX E

deck target area shall be large enough to ensure that all impacts are on the deck before striking the vertical target. The vertical bulkhead shall be thick enough to deflect the munition.

E3.4.4 Recording equipment. Use a motion picture camera operating at a minimum of 64 frames per second, covering both the deck and vertical targets, and the intervening flight of the munition. Visual observation is also required.

E3.4.5 Velocity measuring instrumentation. Velocity measuring instrumentation is used to measure the speed of the munition prior to impact.

E3.4.6 Recovery equipment. If the condition of the fuze cannot be determined without removal from the munition, special equipment will be necessary to remove the fuze with safety.

E3.5. PROCEDURE

E3.5.1 Temperature. Perform the test with the munition at ambient temperature.

E3.5.2 Munition assembly. Assemble the fuze with all of its explosive components, with the exception of an inert booster, to the inert munition of the type with which it is intended to be used. If a round accidentally pulls off the aircraft, the fuze would normally be in the unarmed or safe condition. Make the fuze safe or prevent it from arming by the safety feature that is used while it is being carried on the aircraft. If pull-off compromises a safety feature, such as removal of an arming wire, this condition should be duplicated for the test.

E3.5.3 Rocket motors. If the test munition is normally propelled by a rocket motor, the motor attached to the warhead shall be inert, or if designed to carry a sub-caliber rocket motor for the purpose of this test, the motor shall be burned out before striking the target. This is done to assure that there shall be no confusion between fuze detonation and motor deflagration.

E3.5.4 Launcher orientation. The launcher shall be oriented to give an angle of impact such as that obtained with a munition breaking loose from a landing aircraft.

E3.5.5 Launch. The test munition shall be accelerated to a velocity of approximately 45.7 m/s (150 ft/s) by suitable means, such as a rocket motor, before striking the target. Engineering judgment shall be exercised in attaining desired acceleration. If the fuze is acceleration sensitive, the test acceleration shall be safely below the normal arming acceleration so that the results of this test are not invalidated by improper simulation of actual pull-off conditions.

E3.5.6 Recovery. Recover the munition after impact. Observe and record deformation of the fuze, any functioning of the fuze, and degree of arming, if any.

E3.5.7 Compliance. Analyze the test results and determine whether or not the test article meets the pass/fail criteria in E3.3. Functioning of the fuze would indicate: (a) the mechanism intended to prevent arming failed either during or after initial impact and permitted arming to proceed, or (b) the fuze functioned on severe impact, even though actually held in the safe condition. Continue testing the specified number of items.

E3.6. ALTERNATE AND OPTIONAL TESTS

None.

E3.7. RELATED INFORMATION

None.

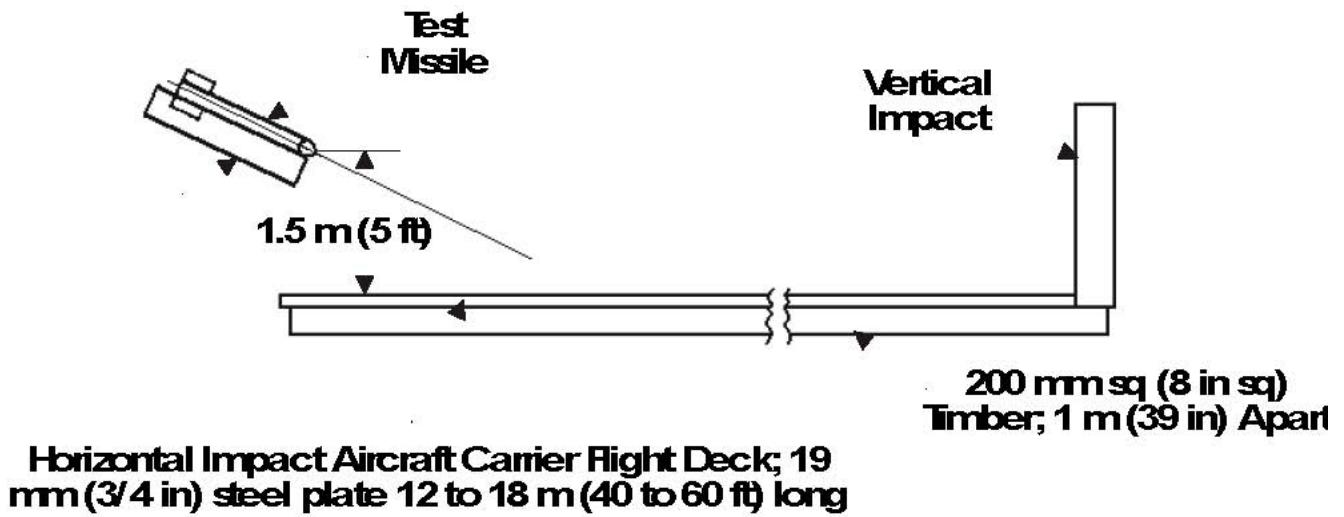

FIGURE E3-1. Arrested Landing Pull-off Test Set-up

TEST E4

CATAPULT AND ARRESTED LANDING FORCES

E4.1 PURPOSE

This is a field safety and reliability test. The fuze must withstand forces encountered on catapult takeoff and arrested landing aboard an aircraft carrier.

E4.2 DESCRIPTION

E4.2.1 General. A complete fuze with all explosive components installed is catapulted or accelerated to obtain the acceleration-time patterns which could be encountered during catapult takeoff or arrested landing aboard an aircraft carrier. Each accelerated fuze is examined for evidence of unsafe conditions. Some of the fuzes are disassembled for more detailed examination. The others are tested for functioning.

E4.2.2 Applicable publications. All standards, specifications, drawings, procedures and manuals which form a part of this test are listed in Section 2 of the introduction to this standard.

E4.2.3 Test documentation. Test plans, performance records, equipment, conditions, results, and analysis shall be documented in accordance with 4.8 of the general requirements to this standard.

E4.3 CRITERIA FOR PASSING TEST

E4.3.1 Fuze condition. At the completion of this test, the fuze shall be safe for transportation, storage, handling and use, as well as operable in accordance with 4.6.2.1a and 4.6.2.2 of the general requirements to this standard.

E4.3.2 Decision basis. Breakdown, inspection, other appropriate tests and engineering judgment shall form the basis for the decision that fuzes have passed or failed the test.

E4.4 EQUIPMENT

E4.4.1 Acceleration device. Use shipboard catapults, land based catapults, rocket launchers, rocket sleds, or other devices which can produce the required acceleration-time patterns may be employed.

E4.4.2 Munition mounting. Aircraft, test carriage, or other device suitable for mounting the munition for acceleration.

E4.4.3 Munition. Inert munitions or test fixtures as required. The inert-loaded munition or test fixture shall be dynamically equivalent to the explosive-loaded munition.

E4.4.4 Accelerometer. Several types of piezoelectric accelerometers are commercially available which will yield very accurate acceleration-time histories. The type of accelerometer used and its placement will depend upon the environment and configuration of the item being tested.

E4.4.5 Fuze disassembly, inspection and test equipment.

E4.5 PROCEDURE

E4.5.1 Temperature. The test shall be performed with the fuze at ambient temperature. An estimate of the temperature of the fuze at the time of test shall be recorded.

E4.5.2 Fuze inspection. When specified in the test directive, inspect each fuze prior to the test to ensure that it is properly assembled in the unarmed condition.

E4.5.3 Fuze mounting. Assemble the fuze to the inert bomb, rocket, or guided missile for which it was designed or to a suitable test fixture.

E4.5.4 Accelerometers. Accelerometers shall be placed near the center of gravity of the fuze to measure the acceleration.

E4.5.5 Munition mounting. The munition shall be mounted on aircraft suspension equipment on the aircraft, test carriages, or other devices suitable for the acceleration tests.

E4.5.6 Acceleration. A minimum of three fuzes shall be accelerated. Each fuze shall be accelerated three times in each of three orientations. The orientations shall be nose forward, tail forward, and side forward. The side forward orientation shall be such as to expose what is considered to be the most vulnerable plane of weakness. The magnitude and duration of the accelerations shall over-simulate those conditions that the fuzes would experience when attached to a munition and carried on an aircraft that is catapulted or subjected to arrested landings.

E4.5.6.1 Magnitude. The magnitude of the accelerations shall be 150 percent of the maximum accelerations to be expected in service use. Figure E4-1 provides profiles of the forces to be met.

E4.5.6.2 Duration. The acceleration rise and dwell time shall approximate those expected in service use.

E4.5.7 Interim inspection. After each acceleration and before handling, examine the accelerated fuze, munition and test fixture for any evidence of unsafe conditions.

E4.5.8 Final inspection. After completion of the test (9 accelerations per fuze), examine the fuzes for apparent safety defects. Particular attention shall be given to possible movement due to acceleration of fuze parts or components which could cause unsafe conditions or render the fuze inoperable. Where necessary, disassemble the fuze for a more detailed examination.

E4.5.9 Function test. Perform complete functioning tests on those fuzes not disassembled.

E4.5.10 Compliance. Analyze the test results and determine whether or not the test article meets the pass/fail criteria in Section 3. Continue testing the specified number of items.

E4.6 ALTERNATE AND OPTIONAL TESTS

None.

E4.7 RELATED INFORMATION

E4.7.1 Test conditions. Safety requirements for the fuze shall dictate the selection of the test conditions and munitions for this test. For example, the same fuze may be used in munitions which are mounted in widely different locations and retention mechanisms and which are carried by different aircraft. The types of munitions in which the fuze will be assembled, the suspension

MIL-STD-331C
w/CHANGE 1
APPENDIX E

method and location, and the catapults and arresting gear characteristics should be given careful consideration in planning the test. Reasonable and compatible test conditions which are likely to produce the most critical loading conditions should be chosen.

E4.7.2 Bibliography.

DP-75-27, *Mk 82 Bomb Dud Investigation*, R.L Russakov, Pacific Missile Test Center, 1 July 1975.

FOR FLIGHT: $t = 0.20$ TO 1.0 S
 FOR ARRESTED LANDING: $t = 0.03$ TO 0.10 S
 (WITH LONGITUDINAL LOAD FACTORS UP TO ± 2.0)
 FOR ARRESTED LANDING: $t = 0.15$ TO 0.50 S
 (WITH LONGITUDINAL LOAD FACTORS ABOVE 2.0)
 FOR CATAPULTING: $t = 0.02$ TO 0.40 S
 FOR NON-ARRESTED LANDINGS: $t = 0.03$ TO 1.0 S

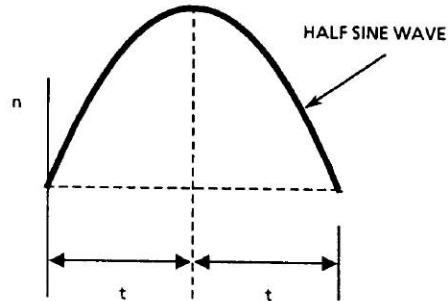

FOR ALL CASES ABOVE, $n =$ LOAD FACTOR

DATA NOT APPLICABLE TO HELICOPTERS

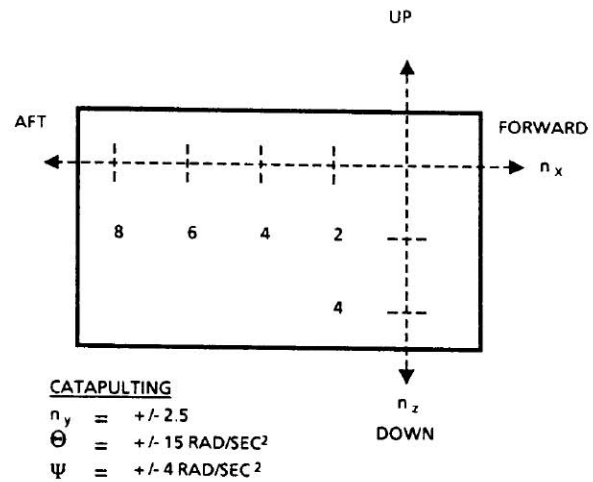
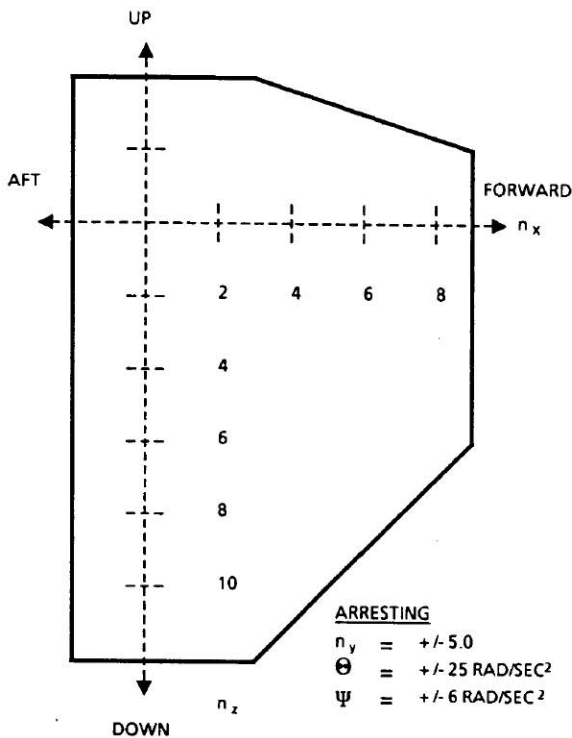

FIGURE E4-1. Design Limit Load Factors for Wing-mounted Stores

TEST E5

SIMULATED PARACHUTE AIR DELIVERY

E5.1 PURPOSE

This is a field safety and reliability test simulating air delivery of packaged fuzes or fuzed munitions. The fuzes must withstand the forces encountered in low-velocity, high-velocity (if required) and malfunctioning air delivery drops.

E5.2 DESCRIPTION

E5.2.1 General. In this test, packaged fuzes and those assembled to warheads or complete rounds are subjected to impacts encountered in low-velocity, high-velocity and malfunctioning parachute delivery.

E5.2.1.1 Low-velocity simulation. Fuzes are subjected to an impact velocity of 8.7 m/s (28.5 ft/s).

E5.2.1.2 Malfunctioning drop simulation. Fuzes are subjected to an impact velocity of 45.7 m/s (150 ft/s).

E5.2.1.3 High-velocity drop simulation (if required). Fuzes are subjected to an impact velocity of 27.4 m/s (90 ft/s).

E5.2.2 Fuze configuration. The fuzes are tested in their standard package, unit or bulk, or assembled to associated munitions. All explosive elements are present in the fuze during the test. Warheads and other components may be inertly loaded.

E5.2.3 Number of drops. Each test article is dropped once per impact orientation of nose up, nose down and sideways.

E5.2.4 Applicable publications. All standards, specifications, drawings, procedures and manuals which form a part of this test are listed in Section 2 of the introduction to this standard.

E5.2.5 Test documentation. Test plans, performance records, equipment, conditions, results, and analysis shall be documented in accordance with 4.8 of the general requirements to this standard.

E5.3 CRITERIA FOR PASSING TEST

E5.3.1 Low-velocity and high-velocity test. At the completion of this test, the fuzes shall be safe for transportation, storage, handling and use, as well as operable in accordance with 4.6.2.1a and 4.6.2.2 of the general requirements to this standard.

E5.3.2 Malfunctioning test. At the completion of this test, the fuzes shall be safe for disposal in accordance with 4.6.2.1b of the general requirements to this standard.

E5.3.3 Decision basis. Breakdown, inspection, other appropriate tests and engineering judgment shall form the basis for the decision that fuzes have passed or failed the test.

E5.4 EQUIPMENT

E5.4.1 Drop tower. A suitable drop tower, boom arrangement or crane with quick-release mechanism may be used for free fall drops.

E5.4.2 Acceleration device. A suitable acceleration device may be used to achieve the specified impact velocity in the malfunctioning drop.

E5.4.3 Impact surface. An impact area of compact soil or level hard surface shall be used.

MIL-STD-331C
w/CHANGE 1
APPENDIX E

E5.4.4 Test articles. Fuzes, warheads, or complete rounds in packaged condition shall be used in quantities specified by the test directive.

E5.4.5 Rigging. Standard air delivery rigging equipment, including containers, platforms, and energy absorbers shall be used as required. Retardation devices such as a pilot parachute may be used to ensure the item will impact at the desired orientation and at the required impact velocity.

E5.4.6 Ancillary equipment. Photographic, radiographic, telemetry and disassembly equipment shall be used as required.

E5.5 PROCEDURE

Note: An acceleration device may be used in lieu of free fall to obtain the impact velocity.

E5.5.1 Rigging test articles. Prepare the air delivery system to be dropped by stacking packaged fuzes or fuzes assembled to warheads or complete rounds in the normally shipped orientation. Stacking shall be in accordance with the test directive. Dummy components may be used as partial loading to simulate fuzes or other ammunition components. The rigging instructions shall be specified in the test directive. An example is shown in Figure E5-1.

E5.5.2 Low-velocity test. Release the air delivery system to impact at a minimum velocity of 8.7 m/s (28.5 ft/s) on compact soil or a level hard surface and impacting with the energy absorber on the underside of the load to simulate a low-velocity parachute delivery.

E5.5.3 Malfunctioning test. Release the air delivery system to impact at a minimum velocity of 45.7 m/s (150 ft/s) onto compact soil or a level hard surface to simulate the malfunction velocity in the parachute delivery.

E5.5.4 High-velocity test. See E5.6.2.

E5.5.5 Disassembly. Disassemble the air delivery system. Determine by means of radiographic examination and disassembly or other appropriate methods whether the fuzes have been armed or functioned and are safe to handle. For fuzes subjected to the low-velocity drop, use suitable tests to determine operability.

E5.6 ALTERNATE AND OPTIONAL TESTS

E5.6.1 System without energy absorbers. Alternatively, drop an air delivery system without energy absorbers and without stabilization to impact at a velocity between 24.4 m/s (80 ft/s) and 30.5 m/s (100 ft/s) in the most vulnerable attitude onto a hard surface, such as steel or concrete as a means of determining minimum damage and hazards to be expected in a malfunctioning parachute delivery.

E5.6.2 High-velocity test. Although no formal requirement exists for high impact velocities in the range of 21 to 27.4 m/s (70 to 90 ft/s), it is tactically desirable to deliver fuzes and ammunition in this range of vertical impact velocities. If fuzes and components are satisfactory as tested in E5.5.2 and E5.5.3, above, it is suggested that a system drop be made to impact at high-velocity using rigging instructions specified in the test directive. Fuzes and components should be safe to handle and use and be operable in accordance with E5.3.1.

E5.7. RELATED INFORMATION

E5.7.1 Journal Article Serial Number 40 of the JANAF Fuze Committee, "Air Delivery of Ammunition and Explosives by Parachute," 1 September 1965.

E5.7.2 AR 705-35, *Criteria for Air Portability and Air Drop of Materiel*, 20 October 1967.

MIL-STD-331C
w/CHANGE 1
APPENDIX E

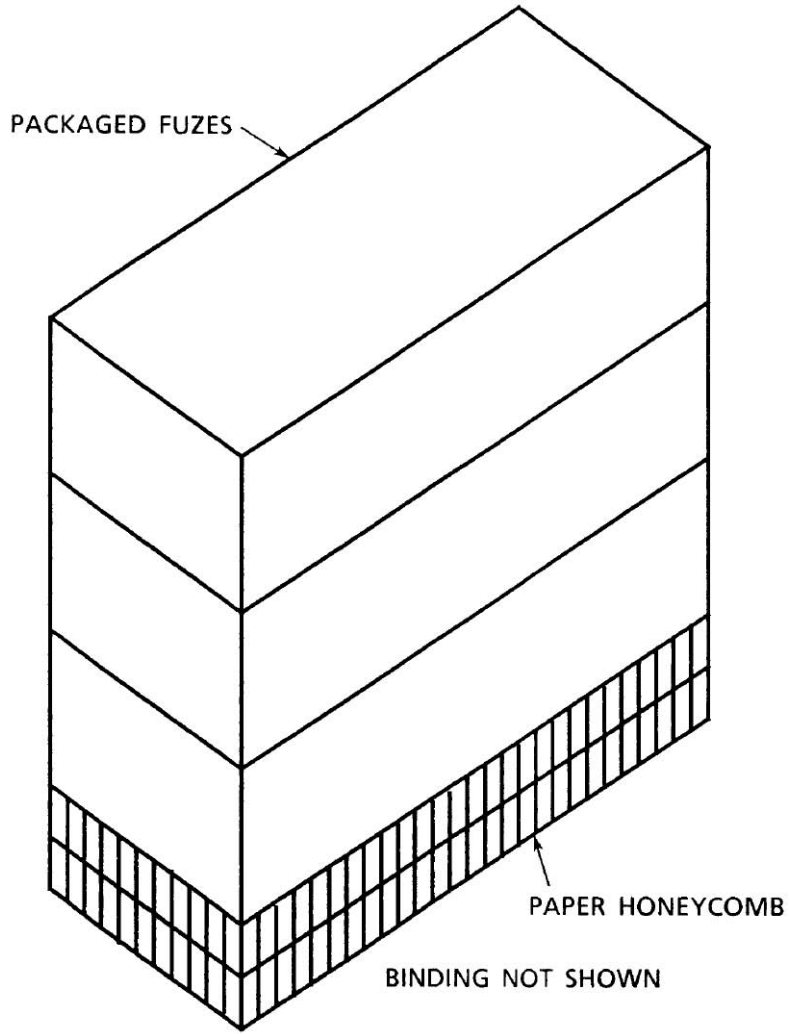

FIGURE E5-1. Example of Simulated Load

APPENDIX F
ELECTRIC AND MAGNETIC INFLUENCE TESTS

TEST F1

ELECTROSTATIC DISCHARGE (ESD)

F1.1 PURPOSE

This is a laboratory safety and reliability test simulating possible handling and transportation conditions. The fuze must withstand high-potential electrostatic discharge (lightning environment is excluded).

F1.2 DESCRIPTION

F1.2.1 General. Bare and packaged unarmed fuzes are subjected to discharges of electrostatic energy at selected exterior points. Each fuze shall be subjected to three tests. The first test, personnel-borne ESD, simulates the maximum electrostatic discharge from the human body and is performed at two different test conditions representative of such discharges. The final two tests, helicopter-borne ESD, performed on packaged and bare fuzes, simulate the maximum expected electrostatic discharge during vertical replenishment by hovering aircraft.

F1.2.1.1 Personnel-borne ESD (bare). This test shall be conducted on bare fuzes to evaluate their safety and operability.

F1.2.1.2 Helicopter-borne ESD (packaged). This test shall be conducted on fuzes in their standard packaged configuration (unit or bulk packaging and shipping container) to evaluate their safety and operability.

F1.2.1.3 Helicopter-borne ESD (bare). This test shall be conducted on bare fuzes to evaluate their safety only.

F1.2.2 Selection of test points. Selection of test points for the fuze or container shall be based on the item's particular points deemed by engineering judgment to be the most susceptible to direct penetration or to excitation of the structure and subsequent internal distribution of the electromagnetic energy from the discharge.

F1.2.2.1 Bare fuzes. Fuzes shall be tested in all expected electrostatically-significant handling configurations, both with and without caps, covers and protective devices, to insure evaluation of realistic worst-case conditions. When selecting test points on a fuze, special attention and consideration shall be given to connectors, pins, apertures, slots, joints and other discontinuities that may transfer energy by electric (E-field) or magnetic (H-field) coupling.

F1.2.2.2 Packaged fuzes. Fuzes shall be in their shipping containers in their normal shipping configurations (for example, intact solder-seal lids or metal foil tapes or wraps). When selecting test points on a container, special attention shall be given to joints and other discontinuities that may transfer energy by electric (E-field) or magnetic (H-field) coupling.

F1.2.3 Environmental conditions. The test shall be conducted on fuzes at an ambient temperature of $+23^{\circ}\text{C}\pm 10^{\circ}\text{C}$ ($+73^{\circ}\text{F}\pm 18^{\circ}\text{F}$). Relative humidity of the ambient atmosphere shall be no greater than 50%. The fuze shall be preconditioned at $+23^{\circ}\text{C}\pm 10^{\circ}\text{C}$ ($+73^{\circ}\text{F}\pm 18^{\circ}\text{F}$), relative humidity no greater than 50% for no less than 24 hours prior to this test.

F1.2.4 Fuze configuration. The fuzes shall be completely assembled except that lead and booster charges, if considered to be insensitive or inaccessible to electrostatic discharge, may be omitted to facilitate testing. If any explosive elements are removed, care should be exercised to

preserve electromagnetic equivalency of the resulting configuration.

F1.2.5 Applicable publications. All standards, specifications, drawings, procedures and manuals which form a part of this test are listed in Section 2 of the introduction to this standard. Special attention is directed to MIL-HDBK-1512, MIL-STD-322 and MIL-I-23659 which have specific applications.

F1.2.6 Test documentation. Test plans, performance records, equipment, conditions, results, and analysis shall be documented in accordance with 4.8 of the general requirements to this standard. The test plan shall also specify:

- a. The number and configuration of fuzes for each discharge; the location of discharge points; the number of times each fuze may be subjected to discharge; the type of electrode to be used (see F1.4.4); the discharge gap or description of the mechanism utilized to move the electrode toward the test item (see F1.4.5); and the test sequence (see F1.5.2).
- b. The performance requirements, pre-test data (for example, electroexplosive device (EED) bridge resistance and thermal time constants) and parameters for determining proper evaluation of the fuze during and after test, including how cumulative damage, if any is to be assessed.

F1.3 CRITERIA FOR PASSING TEST

F1.3.1 Fuze condition after personnel-borne ESD (bare) and helicopter-borne ESD (packaged) tests. At the completion of these tests, the fuze shall be safe for transportation, storage, handling and use, as well as operable in accordance with 4.6.2.1a and 4.6.2.2 of the general requirements to this standard.

F1.3.2 Fuze condition after helicopter-borne ESD (bare) test. At the completion of this test, the fuze shall be safe for transportation, storage, handling and use in accordance with 4.6.2.2 of the general requirements to this standard. The fuze does not have to be operable.

F1.3.3 Decision basis. Breakdown, inspection, other appropriate tests and engineering judgment shall form the basis for the decision that fuzes have passed or failed the test.

F1.4. EQUIPMENT

F1.4.1 Test apparatus. The functional electrical schematic for the test apparatus is shown in Figure F1-1.

F1.4.2 Energy delivery capability. The energy delivery capability of the test apparatus shall be verified and recorded on a daily basis. If a salient is used on the test item, it shall be considered part of the discharge circuit.

F1.4.2.1 Personnel-borne ESD test. The energy delivered to each of the calibration test loads given in Table F1-1 shall be between 0.18% and 0.22% (when using a 500 ohm series resistance) or between 0.018% and 0.022% (when using a 5000 ohm series resistance) of the energy stored on capacitor C. F1.7.3.2.1 provides a description of the threat to fuzes or their subsystems caused by an electrostatic discharge from a human body. F1.7.4 provides a description of the required instrumentation and a procedure for measuring the energy delivered by the test apparatus used to simulate the threat. Calibration test waveforms should fall within the bounds specified in Figures F1-2 through F1-5, as applicable.

F1.4.2.2 Helicopter-borne ESD test. The energy delivered to the calibration test load given in Table F1-I shall be between 80% and 100% of the energy stored on capacitor C.

F1.4.3 Circuit component characteristics.

F1.4.3.1 Power supply. The power supply shall provide both positive and negative test voltages with respect to ground.

F1.4.3.2 Isolation circuitry. Isolation circuitry shall isolate the test item from the charging circuit during charging of capacitor C and shall isolate the power supply from the discharge circuit during discharge to the test item.

F1.4.3.3 Series resistance. The series resistance R shall be non-inductive. For the air replenishment test, R represents the allowable total discharge circuit resistance, excluding the test item (see F1.4.1).

F1.4.3.4 Capacitor. Capacitor C shall be chosen to minimize inductance and leakage.

F1.4.3.5 Storage Scope. To properly record test waveforms, an oscilloscope is required having at least a DC to 100 MHz frequency response, 50-ohm input impedance, and both storage and hard-copy capability.

F1.4.3.6 Test parameters. The voltage, capacitance, resistance, discharge circuit inductance, and calibration test load for each test procedure, including the inductance of the capacitor and wiring to the probes shall be in accordance with the values in Table F1-I. Inductance shall be measured at a nominal 1 kHz frequency.

F1.4.4 Electrode characteristics. The test electrode shall be metal and have a size and shape that minimize corona. The electrode surface shall be maintained smooth, clean and shiny to insure high electrical conductivity and uniformity of discharge.

F1.4.5 Electrode control. A mechanism shall be provided to cause the test electrode either to discharge to the test item through a previously specified fixed gap (see Section F1.2.6a) or to move toward the test item at the speed at which it was calibrated. The electrode may be snubbed to prevent hitting the test item. Where it is desired to insure that the discharge is directed to a particular point on the test item or to assure contact by the electrode without mechanical shock, an electrically conductive salient may be attached to the test item. In this case, it shall be established that the salient can withstand the discharge arc and that the integument of the test item with salient omitted can also withstand a direct discharge arc. The salient shall be included in energy delivery calibration tests (see F1.4.2).

F1.4.6 Safety considerations. Proper safety interlocks, switches, grounds and procedures shall be used to protect test personnel from electrical and explosive hazards. A grounding rod with insulated handle (or equivalent) shall be provided to short circuit the test electrode to test-circuit ground while test personnel are setting up for the next discharge.

F1.5 PROCEDURE

F1.5.1 Test. Perform the human body discharge test and the two air replenishment tests in accordance with the test plan. Test details, for example, configurations, order of trials, inspection and number of trials, shall be at the discretion of the test designer and shall be documented in the test plan.

F1.5.2 Test sequence. Items shall be tested as follows:

- a. The test item shall be positioned such that the test electrode can discharge to the first designated test point on the item.
- b. Capacitor C shall be charged to the chosen voltage and polarity. After C is fully charged and has been isolated from the power supply, the test electrode is allowed to discharge to the test point.
- c. The capacitor discharge energy shall be applied sequentially to each of the designated test points. The capacitor shall be fully recharged for each point.
- d. The test sequence shall be stopped if the test item at any time gives an indication of failure to pass the test, or at the discretion of the test activity. After removal of residual electrical energy, the fuze shall be inspected for compliance with F1.3. Otherwise, sequential

application of capacitor discharge energy to all selected test item points shall be continued.

- e. The above sequence shall be repeated with opposite polarity voltage.
- f. Steps a through e shall be performed for the remaining test items.

F1.5.3 Number of test sequences. A minimum of 22 test sequences shall be conducted when testing to the personnel-borne ESD threat in order to demonstrate 90% reliability with 90% confidence. This minimum number of sequences may be reduced to 10 (80% reliability, 85% confidence) when testing to the helicopter-borne ESD threat. For the purposes of this standard, a test sequence is defined as a series of discharges to the equipment-under-test at the test points identified in the pre-test assessment. Subsequent sequences may be conducted by using different items/munitions or on the same item/munition with a different set of EED's and electronic/electrical subsystems. The confidence level and reliability of test data versus the number of test sequences shall be considered when determining the number of test sequences.

F1.5.4 Compliance. Analyze the test results and determine whether or not the test article meets the pass/fail criteria in F1.3.

F1.6. ALTERNATE AND OPTIONAL TESTS

F1.6.1 Information testing. Testing at intermediate voltages between zero and 300 kilovolts should also be conducted to identify voltage breakdown paths which may not be observed at the voltages given in Table F1-1 and which may have an adverse effect on the test item. Parameters that should be considered for additional tests are provided in Table F1-II.

F1.6.2 Test to determine response of an armed fuze to electrostatic discharge. Fuze development testing or operational conditions may require that an armed fuze be handled. For these cases, it is recommended that the human body discharge test be conducted on armed fuzes to establish if they are sensitive to electrostatic discharges up to 25 kilovolts. The results of this test will also be helpful in establishing procedures for disposing of the fuze or rendering it safe by Explosive Ordnance Disposal personnel.

F1.7. RELATED INFORMATION

F1.7.1 Relation to other environmental tests. Electrostatic discharge tests should be conducted either singly or as part of a sequence after other environmental tests have been completed on the fuze. It is suggested that fuzes be evaluated for susceptibility to electrostatic discharge after they have been attached to their associated weapons, if practical.

F1.7.2 Number of tests per fuze. The number of capacitor discharges to a particular fuze, bare or packaged, has not been specified and is at the discretion of the test activity. The determination of the permissible number of discharges should be based in part on whether cumulative damage should be counted in assessing whether the fuze meets the passing criteria of F1.3.

F1.7.3 Background.

F1.7.3.1 Nature of the problem. Many modern weapons contain EED's which are used to initiate a variety of functions such as rocket motor ignition, fuze and warhead detonation, power cartridge and fuze actuation, stores ejection, and many others. Many fuzes have electronic parts which include transistors, integrated circuits and various other solid-state devices related to timing, arming or firing functions. Through a normal logistic cycle, weapons undergo various phases of handling such as crating, uncrating, wrapping in protective plastics, removal from barrier bags, assembling, and transferring. These processes may result in the development of an electrostatic charge on the handler, transfer equipment, shipping containers, munitions or any other

ungrounded object. The clothing worn by handling personnel, if made from a synthetic fiber, is especially prone to producing high levels of electrostatic charge. Hovering aircraft used in vertical replenishment also develop a significant electrostatic charge. This may be discharged to an exposed lead of an EED or into an electronic circuit upon contact between the handler or associated equipment and the munition. If the charge is of sufficient magnitude, so that the energy dissipated exceeds the initiation threshold for the EED, an accidental initiation of the device will occur, resulting in either a serious hazard or dud weapon, depending on the function of the affected EED. If an electronic component is overloaded by excessive voltage, parametric or gross changes may occur that are detrimental to electronic functions such as signal processing, timing, arming and firing.

F1.7.3.2 Electrostatic environment.

F1.7.3.2.1 Personnel-borne. The physiological characteristics which affect the electrostatic hazard vary over a wide range. The degree of the hazard also depends on the type of clothing worn and the relative humidity of the ambient air. In most cases the upper-bound hazard may be represented by charging a low-loss, low-inductance 500-picofarad capacitor to 25 kilovolts and discharging it through a resistor with not more than 5 microhenries of total circuit inductance.

F1.7.3.2.2 Helicopter-borne. Helicopters and other hovering aircraft become electrostatically charged by ion emission from the engines and by the triboelectric charge separation on airfoils. Their characteristics vary over a wide range, but a typical upper bound may be represented by a 1000-picofarad capacitor charged to 300 kilovolts.

F1.7.4 Waveform characterization of the personnel-borne ESD threat. The heavy curves in Figures F1-2 and F1-3 represent typical 25 kilovolt pulses for the 500 ohm and 5000 ohm series resistances respectively. Risetimes are approximately 15 nanoseconds (10% to 90% of peak value). The range of waveforms for equipment used to simulate the personnel-borne ESD threat should fall within the bounds of the curves given in those figures. Figures F1-4 and F1-5 represent typical and boundaries for voltage waveforms as measured on a storage scope using the calibration circuit presented in Figure F1-6. The 1-ohm resistor should be coaxial in order to ensure the proper frequency response. Note that the test circuit in Figure F1-6 is commercially available. If possible, the probe should be touching the resistor contact when the discharge is triggered. This will produce the most consistent waveforms. Waveforms should be characterized before and after testing and included in the test report.

F1.7.5 Bibliography.

F1.7.5.1 Technical Report 62-72, *Helicopter Static-Electricity Measurements*, by James M. Seibert, US Army Transportation Research Center, June 1962.

F1.7.5.2. Technical Report 69-90, *Investigation of CH-54A Electrostatic Charging and of Active Electrostatic Discharge Capabilities*, by M. C. Becher, US Army Aviation Material Laboratories, January 1970.

F1.7.5.3 Technical Report TR-2207, *Evaluation of Dynasciences Model D-04E Active Electrostatic Discharge System Mounted on the CH-46A Helicopter*, by Charles L. Berkey, Naval Weapons Laboratory, September 1968.

F1.7.5.4 *Electromagnetic Criteria for US Army Missile Systems: EMC, EMR, EM, EMP, ESD, and Lightning*, by Charles D. Ponds, Colsa, Inc., February 1987.

F1.7.5.5 UK Ministry of Aviation - Explosives Research and Development Establishment Report No. 18/R/62, *Measurement of Human Capacitance and Resistance in Relation to Electrostatic Hazards with Primary Explosives*, 17 August 1962.

F1.7.5.6 NATO STANAG 4235, *Electrostatic Environmental Conditions Affecting the Design of Materiel for Use by NATO Forces*.

MIL-STD-331C
w/CHANGE 1
APPENDIX F

F1.7.5.7 NATO STANAG 4239, *Electrostatic Discharge Testing of Munitions Containing Electroexplosive Devices.*

F1.7.5.8 NATO AOP 24, *Assessment and Testing of Munitions Containing Electroexplosive Devices to the Requirements of STANAG 4239.*

TABLE F1-I. Test Parameters.

Discharge Procedure	Voltage on C (kilovolts)	Capacitor C (picofarads)	Resistance R (ohms)	Discharge Inductance (microhenries)	Calibration Test Load (ohms)
Personnel	+25±5%	500±5%	5000±5%	< 5	1±5%
Personnel	-25±5%	500±5%	5000±5%	< 5	1±5%
Personnel	+25±5%	500±5%	500±5%	< 5	1±5%
Personnel	-25±5%	500±5%	500±5%	< 5	1±5%
Helicopter	+300±5%	1000±10%	1 max *	< 20	100±5%
Helicopter	-300±5%	1000±10%	1 max *	< 20	100±5%

* Total distributed discharge circuit resistance.

MIL-STD-331C
w/CHANGE 1
APPENDIX F

TABLE F1-II. Suggested Informational Test Parameters

Discharge Procedure	Voltage on C (kilovolts)	Capacitor C (picofarads)	Resistance R (ohms)	Discharge Inductance (microhenries)	Calibration Test Load (ohms)
Personnel	+5±5%	500±5%	5000±5%	< 5	1±5%
Personnel	-5±5%	500±5%	5000±5%	< 5	1±5%
Personnel	+5±5%	500±5%	500±5%	< 5	1±5%
Personnel	-5±5%	500±5%	500±5%	< 5	1±5%
Personnel	+10±5%	500±5%	5000±5%	< 5	1±5%
Personnel	-10±5%	500±5%	5000±5%	< 5	1±5%
Personnel	+10±5%	500±5%	500±5%	< 5	1±5%
Personnel	-10±5%	500±5%	500±5%	< 5	1±5%
Personnel	+15±5%	500±5%	5000±5%	< 5	1±5%
Personnel	-15±5%	500±5%	5000±5%	< 5	1±5%
Personnel	+15±5%	500±5%	500±5%	< 5	1±5%
Personnel	-15±5%	500±5%	500±5%	< 5	1±5%
Personnel	+20±5%	500±5%	5000±5%	< 5	1±5%
Personnel	-20±5%	500±5%	5000±5%	< 5	1±5%
Personnel	+20±5%	500±5%	500±5%	< 5	1±5%
Personnel	-20±5%	500±5%	500±5%	< 5	1±5%
Helicopter	+25±5%	1000±10%	1 max *	< 20	100±5%
Helicopter	-25±5%	1000±10%	1 max *	< 20	100±5%
Helicopter	+50±5%	1000±10%	1 max *	< 20	100±5%
Helicopter	-50±5%	1000±10%	1 max *	< 20	100±5%
Helicopter	+100±5%	1000±10%	1 max *	< 20	100±5%
Helicopter	-100±5%	1000±10%	1 max *	< 20	100±5%
Helicopter	+150±5%	1000±10%	1 max *	< 20	100±5%
Helicopter	-150±5%	1000±10%	1 max *	< 20	100±5%
Helicopter	+200±5%	1000±10%	1 max *	< 20	100±5%
Helicopter	-200±5%	1000±10%	1 max *	< 20	100±5%
Helicopter	+250±5%	1000±10%	1 max *	< 20	100±5%
Helicopter	-250±5%	1000±10%	1 max *	< 20	100±5%

* Total distributed discharge circuit resistance.

MIL-STD-331C
w/CHANGE 1
APPENDIX F

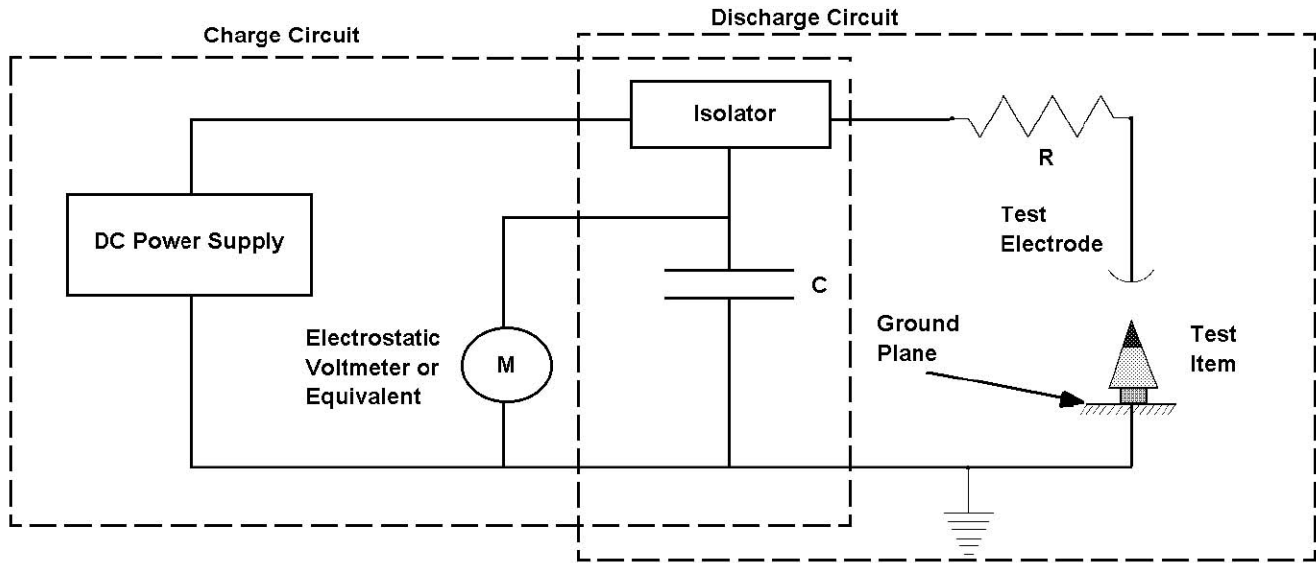

FIGURE F1-1. Functional Electrical Schematic for Electrostatic Discharge Apparatus

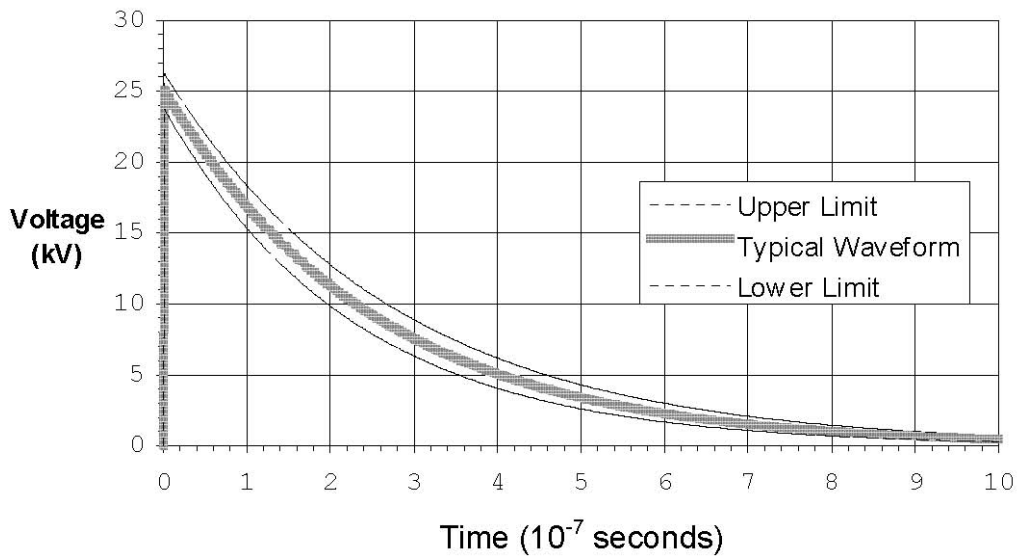

FIGURE F1-2. ESD Waveform (500 ohm series resistance)

MIL-STD-331C
w/CHANGE 1
APPENDIX F

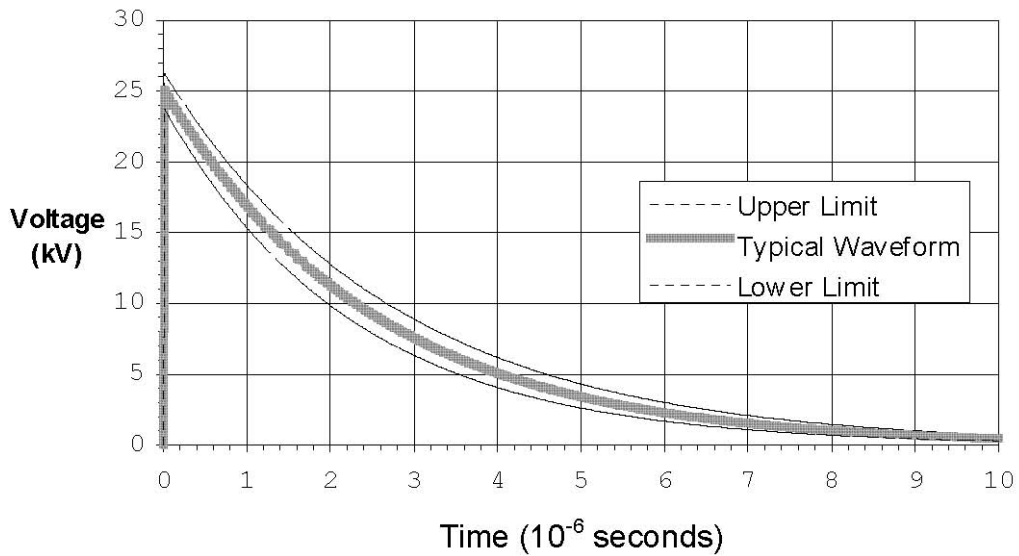

FIGURE F1-3. ESD Waveform (5000 ohm series resistance)

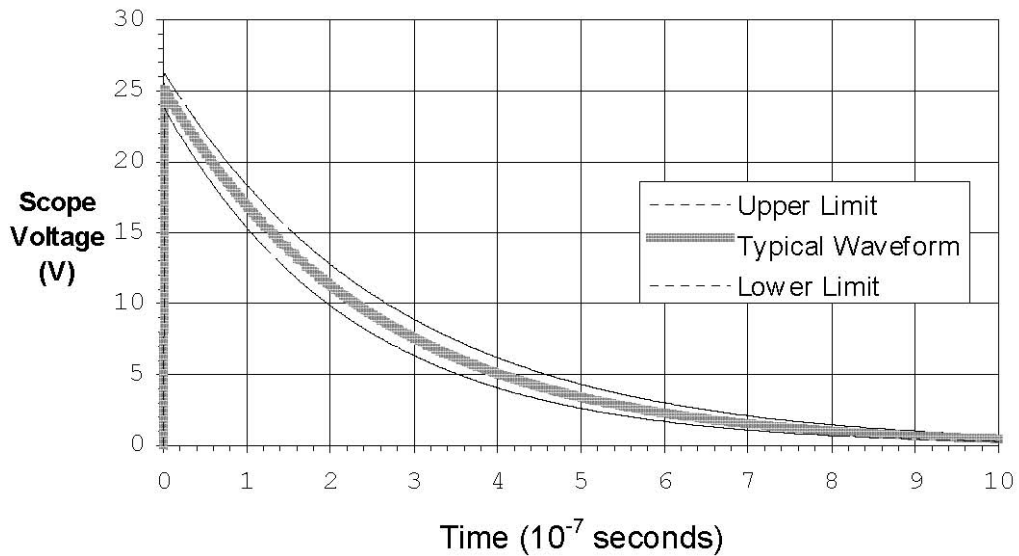

FIGURE F1-4. ESD Waveform on Oscilloscope (500 ohm series resistance)

MIL-STD-331C
w/CHANGE 1
APPENDIX F

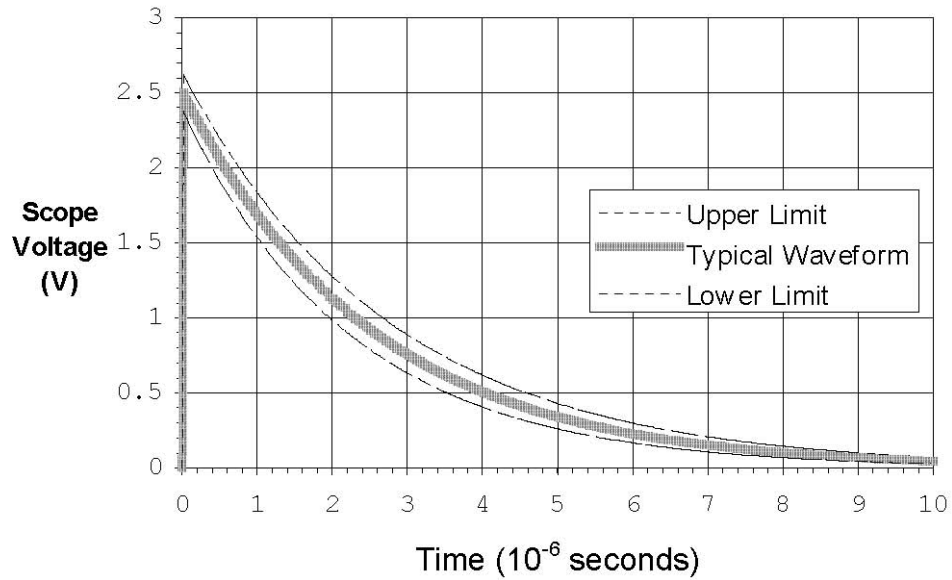

FIGURE F1-5. ESD Waveform on Oscilloscope (5000 ohm series resistance)

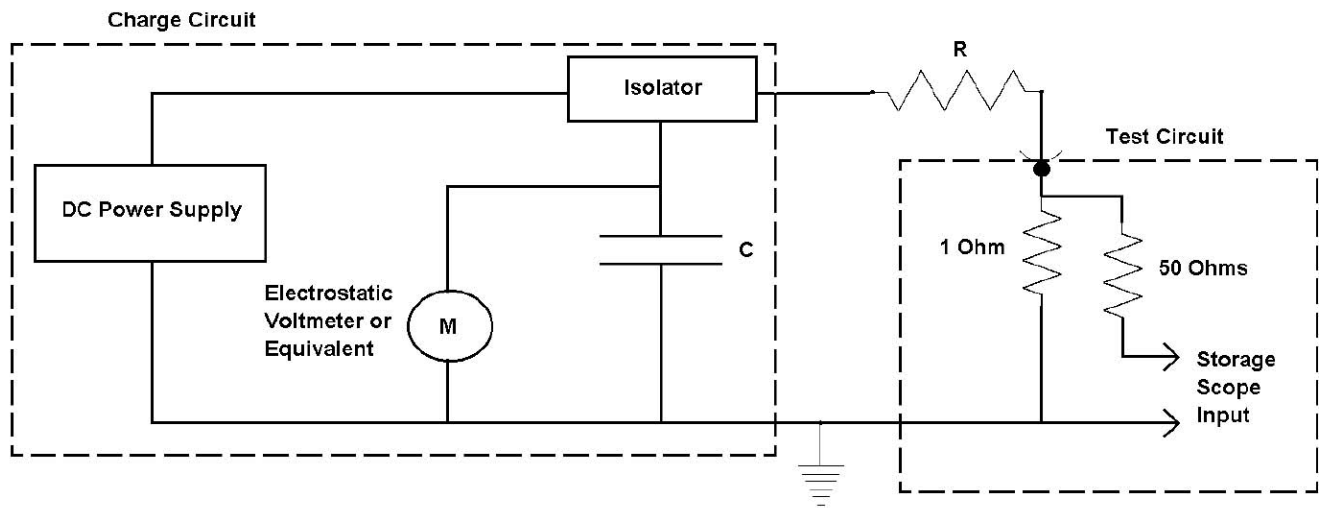

FIGURE F1-6. Personnel-borne ESD Waveform Calibration Circuit

TEST F2

HIGH ALTITUDE ELECTROMAGNETIC PULSE

F2.1 PURPOSE

This is a laboratory test which determines fuze ability to satisfy safety and reliability requirements when exposed to a simulated high-altitude electromagnetic pulse (HEMP) environment. This HEMP potentially could initiate or alter electro-explosive devices (EEDs) and destroy or damage vulnerable electronic components in the fuze.

F2.2 DESCRIPTION:

F2.2.1 General. This test is intended to evaluate fuzes in their storage, transportation and handling configurations. Testing of fuzes with munitions in their tactical configurations is discussed under F2.6. Fuzes shall be subjected to one of the simulated electromagnetic pulse environments described below. Where the test capability is available, the classified HEMP environment shall be utilized. These environments are applicable to altitudes less than 20,000 meters.

F2.2.1.1 Unclassified HEMP. The unclassified HEMP (see F2.7.6.1) is defined as:

$$E(t) = 5.25 \times 10^4 (e^{-4 \times 10^6 t} - e^{4.76 \times 10^8 t})$$

and

$$H(t) = E(t) \div z$$

Where:

T= time in seconds;

z = 377 ohms, the characteristic impedance of free space;

E= is the electric field in volts/meter; and

H= is the magnetic field in amperes/meter.

The above equation has a pulse wave shape with time, with a peak field strength (Ep) of 50 kilovolts per meter, a 10 to 90 percent rise time of 4.15 nanoseconds, a time to half-value of 185.5 nanoseconds and a time duration between 0.1 Ep values of 587.8 nanoseconds. The minimum requirements for the simulation of this waveform for the purpose of this test are presented in Figure 2-2.

F2.2.1.2 Unclassified HEMP. The unclassified HEMP environment is defined in MIL-STD-461, Figure RS105-1, and in MIL-STD-464, Figure 2-2..

F2.2.2 Fuze configuration. The fuze shall be completely assembled, including all electronic circuits and electroexplosive devices that are a part of the fuze design. Lead and booster charges may be omitted to facilitate testing, if considered insensitive or inaccessible to HEMP, or substituted with appropriate inert explosive component simulant provided that the electromagnetic configuration of the munition is maintained. If the fuze is normally shipped or stored on a munition, then the test shall be conducted with the fuze assembled in an inert test munition that provides the

MIL-STD-331C
w/CHANGE 1
APPENDIX F

same electromagnetic characteristics, such as conductivity, shielding, internal and external wiring of the operational munition. If the fuze is used in multiple munitions, the test shall be conducted in each munition or the munition in which the fuze is considered to be the most susceptible to HEMP. If the fuze is not normally installed in a munition for shipping or storage, then the fuze in its standard packaged configuration shall be tested. If the fuze is normally shipped or stored unpackaged, it shall be tested in the unpackaged configuration. The fuze configurations chosen for the test shall be based on all known transportation, storage and handling configurations and the susceptibility analyses as described in F2.2.5.1 of this test; see also F2.7.4.3.

F2.2.3 Applicable publications. All standards, specifications, procedures and manuals which form a part of this test are listed in Section 2 of this standard.

F2.2.4 Number of test items.

- a. If the item is to be instrumented, a single test item is sufficient for each individual test sequence (i.e., operational mode, test configuration and orientation).
- b. If the item is not to be instrumented, a minimum of 10 items is required for each individual test. Each individual test will include exposure to at least 10 HEMP pulses. For tests where 10 items are not available, see F2.3.2.2.

F2.2.5 Documentation. Test plans, performance records, equipment, conditions, results, and analyses shall be documented in accordance with section 4.8 of the general requirements of this standard. The following unique requirements also apply.

F2.2.5.1 Analyses. The HEMP coupling analyses shall be conducted for all known transportation, storage and handling configurations for the fuze. The analyses should determine and provide the most significant system configurations, test configurations and orientations; whether the fuze is to be instrumented for test; the determination of the parameters to be monitored; the expected stress levels; the component thresholds for upset and permanent damage; prioritization of likely failure modes and rationale for the components to be instrumented; etc.

F2.2.5.2 Test plan. The formulation of an appropriate test plan shall be based on the analyses of F2.2.5.1. The test plan shall include:

- a. Identification of the fuze items to be tested at the applicable level of component integration (i.e., system, munition, fuze, subsystem, assembly, circuit, individual component, etc.), and the following pertinent data and information:
 1. The tests and parameters to be measured before, during and after the HEMP environment is applied. The test record data sheet format shall be included.
 2. The test points and supporting rationale for choices.
 3. Instrumentation employed for the response measurements.
 4. Ambient conditions.
 5. Functional modes to be evaluated and supporting rationale for choices.
 6. Number of test items and controls:
 - i. See F2.2.4 and F2.3.2.2.
 - ii. The time between pulses shall be greater than 5 Times the thermal time constant of the components of concern.
 7. Physical configuration of the test items and any ancillary equipment when exposed to the test environment, and the number of test items for each configuration, operational

mode and orientation.

8. The number and kinds of spare parts required.
 9. The data to be recorded.
 10. The specified HEMP free field test waveforms and frequency spectra.
 11. The method of operation and monitoring of the equipment.
- b. A description of the test facilities to be employed to include instrumentation and simulator characteristics, environment measurement techniques, and calibration procedures. Also the justification for choosing the simulator or simulation techniques, including the pertinent simulator characteristics needed.
 - c. A description of how the chosen simulator environments resemble and differ from the threat environment and the methodology for extrapolating the test results to those that would result by exposing the system to the threat environment.
 - d. A statement of the specific test levels and test sequences and the survivability requirements to be assigned to each test.
 - e. The controls to protect personnel and equipment in event the fuze functions during test.

F2.2.5.3 Test report. The test report shall contain the test plan, all the data and the conclusions resulting from the tests delineated in the test plan. In particular the test report shall provide:

- a. The transient responses of the sensor outputs, starting with time zero, as well as that of the simulated HEMP field.
- b. A statement of how the simulated environments were measured; where with respect to the sample the measurements were made; and what device or instruments were used.
- c. A detailed description of the instrumentation calibration procedures.
- d. A description of the operational steps used to set up the fuze for tests.
- e. A description of how the actual test procedure differed from the test plan.
- f. Details of the fuze post-exposure status.
- g. A detailed description of how the response information on components, subassemblies and assemblies are analyzed to arrive at an evaluation of the system survivability. This analysis should relate measured data to the components' failure levels.
- h. A statement of whether the fuze has met the criteria for passing the test (Section F2.3) and the rationale for this conclusion including assumptions and engineering judgments made to support the conclusions.

F2.3 CRITERIA FOR PASSING TEST:

F2.3.1 Fuze condition. At the completion of this test, the fuze shall be safe for transportation, storage, handling and use, as well as operable in accordance with 4.6.2.1 and 4.6.2.2a of the general requirements to this standard. The fuze shall perform in accordance with its performance specifications.

F2.3.2 Decision basis. Breakdown, inspection, other appropriate tests and engineering judgment shall form the basis for the decision that fuzes have passed or failed the test.

F2.3.2.1 Instrumented fuzes. For electroexplosive devices, the maximum pin-to-pin and pin-to-case no-fire criteria establish the baseline. For electronic components, threshold damage

MIL-STD-331C
w/CHANGE 1
APPENDIX F

data based on actual tests or analyses may be used; in their absence, Wunsch damage criteria apply. See references F2.7.6.3 and F2.7.6.4. For all components for which a failure represents a safety hazard, a 20-dB safety factor shall be applied to induced power, energy, voltage and/or current, depending on the damage characteristics of the component. For all other components, a 10 dB safety factor shall be applied.

F2.3.2.2 Non-instrumented fuzes. For tests that have used at least 10 items exposed 10 times for each individual test, a test stimulus amplitude of at least threat level is required. For tests that have used less than 10 items, but at least two, a test stimulus amplitude of at least 6dB above threat level is required.

F2.4. TEST EQUIPMENT:

F2.4.1 HEMP simulator. A HEMP simulator such as operated by the Army, Navy or Air Force may be used. The services have used bounded wave simulators as shown in Figure F2-1, large enough to accommodate a large airplane and others small enough to sit on a laboratory work bench. Other simulators meeting the specifications below may also be used. (see F2.7.3).

F2.4.1.1 Field intensity uniformity. With the test munition outside the test area, the field intensity in the test area shall be measured at 6 equally spaced points on the surface that would be generated by rotating the test munition about its center in all directions; the center of rotation will be at the center of the test area. The position of test points shall insure that only one line connected between opposite points will be parallel to the E-field. The field intensities measured on the surface shall not differ by more than 10% from those measured at the center of rotation.

F2.4.1.2 Field intensity loading. To ensure that the test munition does not excessively load the test fields, a dipole cut to the largest dimension of the test munition shall be placed in the center of the test area, parallel to the E-field. Two more identical dipoles are to be placed in the center of the test area so that all three are mutually orthogonal. The current induced in the center of the dipole parallel to the E-field shall be 100 +/- 10% of the current induced by a prior to loading equal intensity radiated plane wave in space. For a bounded wave simulator, this requires that the ratio of the largest dimension of the test munition to the plates' separation distance be 0.6 or less.

F2.4.1.3 Secret HEMP. The equipment shall provide HEMP fields as specified in MIL-STD-461E, Figure RS105-1.

F2.4.2 Fuze instrumentation. The fuze may be instrumented to measure induced currents and/or voltages at the critical circuit locations determined by the analyses of F2.2.5.1. For EEDs, both pin-to-pin currents and pin-to-case voltages shall be monitored. Fuze instrumentation shall not excessively distort the incident field, induce spurious signals in the fuze or alter the data. This may be accomplished with fiber optics or microwaves to transmit data between the fuze under test and the remotely positioned recording instrumentation. Alternately, data can be brought out via well-shielded coaxial lines with connectors in the fuze skin. The lines should be routed perpendicular to the E-field using appropriate RF-absorbent material to minimize electromagnetic coupling. Tests should be performed to insure there are no instrumentation-induced errors.

F2.5 PROCEDURES:

The fuze in its most vulnerable configurations, as described in F2.2.2, shall be exposed to the simulated HEMP. For all test configurations, the fuze shall be so oriented with reference to the incident E-field and H-field as to ensure maximum coupling of energy to all components of concern. If maximum coupling to different components requires different orientations, or if worst case coupling cannot be determined a priority, various orientations shall be used to assure testing in the worst case

conditions.

F2.5.1 Test arrangements. The arrangement that gives maximum coupling shall be used if known; otherwise, both of the following arrangements shall be used.

F2.5.1.1 Monopole. The fuze under test shall be supported by a dielectric structure. One end of the munition shall be grounded, thereby simulating a monopole antenna. The major axis of this arrangement shall be oriented parallel to the electric field.

F2.5.1.2 Dipole. The fuze under test shall be supported by a dielectric structure and isolated from ground, thereby simulating a dipole antenna. The major axis of this arrangement shall be oriented parallel to the electric field.

F2.5.2 Compliance. The fuze shall be tested according to the test plan and the results analyzed to determine whether the fuze meets the pass/fail criteria in F2.3.

F2.6 ALTERNATE AND OPTIONAL TESTS: For those instances where the fuze developer must evaluate the fuze vulnerability to HEMP under tactical conditions, tests shall be performed with the fuzes and munitions in their launch preparation, launch, and flight configurations as applicable. All fuze modifications, instrumentation, analyses, and documentation requirements are identical to those for tests performed in the transportation, storage and handling configurations.

F2.7 RELATED INFORMATION.

F2.7.1 HEMP generation. A nuclear detonation creates an intense electromagnetic Pulse (EMP) in addition to the shock, blast, ionizing radiation, and thermal effects. Although EMP is generated by surface, air, and high altitude nuclear bursts, it is the primary weapons effect of a high-altitude (exoatmospheric) burst and illuminates the largest area on the earth's surface, thousands of square miles. In addition, at distances great enough for the other effects to become small, the high-altitude burst generates the most severe EMP (HEMP) threat. For a high-altitude nuclear burst occurring at altitudes above 40 km, gamma rays collide with air molecules (Compton collisions), causing electrons to be ejected. These Compton recoil electrons spiral under the influence of the earth's magnetic (geomagnetic) field. Spiraling causes them to accelerate, and hence radiate, thereby producing the electromagnetic pulse.

F2.7.2 HEMP Characteristics.

F2.7.2.1 Origin of the unclassified HEMP. High-altitude EMP develops significant field strength over a wide area of coverage. However, its amplitude-time history and polarization are not uniform over this area, and depend primarily on the orientation of the geomagnetic field and the observer's location in comparison to the burst. A double exponential generalized wave shape, independent of observer location, has been developed by the EMP community, and is used as a working characterization (see F2.2.1.1 and Figure F2-2). This constructed waveform represents a composite of extremes that occur in different regions within the area of coverage, combining the shortest rise time, maximum peak amplitude and longest fall time. Because of the geomagnetic dip angle, over the United States, the HEMP is primarily horizontally polarized with a peak electric field amplitude of 50,000 v/m, with a vertical component of 15,000 v/m. This represents the incident fields. The total fields at any point also include reflection of these fields from the ground plane. The total fields can be larger or smaller than the incident fields, depending on polarization. These characteristics are the basis of worst case evaluation of HEMP interaction with fuzes.

F2.7.2.2 Comparison with other EM fields. HEMP is similar to the radiated electromagnetic pulse produced by a lightning strike. However, it has a faster rise time and

illuminates a much larger area with an intense field. The HEMP electric field intensity rises to levels as high 50kv/m in less than ten nanoseconds, and then decays to an insignificant value in less than 1.0 microsecond. Although this time span is very short, the pulse amplitude is much larger than ordinary radio signals. When HEMP is coupled into an object, the object "rings" at one or more resonant frequencies. The current or voltage waveforms induced are thus usually a superposition of damped sinusoids. The ability of HEMP to couple energy to an object often depends strongly on its spectral amplitude at these resonances. In addition to direct excitation of system elements, HEMP energy can be transferred to a munition system by the interconnecting cables which act as receiving antennas and transmission lines.

F2.7.3 Simulation techniques.

F2.7.3.1 Use of HEMP simulators. It is not feasible to explode a nuclear bomb whenever the need to assess the susceptibility of a weapon to HEMP arises. Hence HEMP simulators have been developed to simulate the HEMP environment. As with most environmental simulators, each HEMP simulator has particular strengths and weaknesses with regard to simulating the actual HEMP, depending on the test conditions and the weapon to be tested. Extensive knowledge about the system to be tested and effects to be examined are necessary for selecting a HEMP simulator.

F2.7.3.2 Types of HEMP simulators. Many kinds of HEMP simulators have been developed and are in the process of being developed. Simulation test techniques are similarly in their evolutionary phases. Recent concerns of the Environmental Protection Agency (EPA) about HEMP simulators polluting the environment with their fields has stimulated interest in those which have minimum radiated fields. Also, simulators that cost less to purchase, operate and maintain have become more widely used, adding to their consideration for use as a standard. The equipment and techniques given below are discussed in greater detail in references F2.7.6.5 and F2.7.6.6.

F2.7.3.2.1 Pulse radiation simulators. Biconic Dipole and Resistive Loaded Horizontal Dipole (both horizontally polarized), and Inverted Conical Monopole (vertically polarized) are all classified as pulse radiation simulators. The intensity of the useful test fields that can be radiated by these devices is limited because of the following factors:

- a. Test field intensity falls off inversely with distance.
- b. Test object must be positioned a sufficient distance from the antenna to assure far-field conditions.
- c. Maximum field intensity that can be generated is limited by the state-of-the-art in the design and manufacture of high voltage generators and switches and by their high cost to purchase and maintain.
- d. Field intensity uniformity cannot be maintained across large systems.

F2.7.3.2.2 Bounded wave transmission line simulators. These simulators can be used to establish plane waves within the two plates of a transmission line as depicted in Figure F2-1; this provides vertically polarized fields. Another type makes use of two vertically positioned plates positioned above ground, thereby, providing balanced lines. This type is horizontally polarized and has the advantage of minimum radiated fields, with the external fields at a distance 100 feet from the chamber being down more than 60 dB from those inside the chamber. A third type, called the Crawford cell, was developed by W. Crawford, National Institute of Standards and Technology. This has a three-dimensional shape similar to the parallel plate lines, except it is a coaxial system enclosed on all sides. This cell has the advantage of radiating even less than the balanced line, but for a given size has less test area available. Because the energy delivered to these

transmission lines is more confined than from radiating antennas, the same intensity energy source can establish much higher intensity fields. Where the plates are closer together, the fields can be proportionately higher. It is possible to design a chamber to provide the choice of a 377ohm field, a low impedance field or a high impedance field. This allows simulation of a reflected field that adds or subtracts from the E-field component. These chambers can be used to establish either HEMP fields or CW fields. The maximum HEMP field available from an existing chamber is 125 kv/m; in this case the separation distance between plates is 40 feet. Moving the plates closer increases field intensity; increased field intensity for smaller objects can be obtained in the transition section of this chamber.

F2.7.3.3 Low intensity test fields. Low intensity test fields can be useful in the developmental stage of an item to evaluate weaknesses in the system and to aid in design. However, it is not possible to extrapolate low intensity field effects up to threat levels because of weapon component non-linearities at those levels. Final evaluation of the system is necessary at threat level fields or their equivalents.

F2.7.4 Reasons for HEMP concern. The increasing dependence of military operations on sensitive and sophisticated electronic equipment and the large-scale introduction of semi-conductor devices have significantly increased the possibility of collateral damage and degradation of mission performance due to HEMP. An area of particular concern is the HEMP vulnerability of ordnance. Potential exists for sufficient HEMP energy to be coupled to munitions to initiate EEDs. Fuzes having electronic safety and arming devices with in-line explosive trains are a more serious safety concern than those having conventional, interrupted explosive trains; for the latter, reliability is the primary concern. Furthermore, with the advent of smart weapons, much of the electronics, especially digital logic circuits responsible for propulsion control, arming, and fusing and guidance subsystems, are potentially susceptible to HEMP-induced damage or upset.

F2.7.4.1 EED initiation. In the case of ordnance containing sensitive EEDs, the HEMP energy could cause initiation. The initiation of EEDs could cause a safety hazard for ships, aircraft, weapon systems and personnel by directly functioning the fuze or its safety features or cause the dudding of ordnance. The mechanisms for initiation of the EED could include electrical breakdown through the explosive material between the pin and case as well as pin-to-pin current. Even when the heat generated by the single pulse of energy may be insufficient to initiate an EED, the EED may become permanently desensitized as a result of this thermal influence and fail to function properly at a later time. This latter case presents a reliability problem as the ordnance is effectively dudded.

F2.7.4.2 Electronic system damage or upset. Induced HEMP transients can produce two types of detrimental responses in electrical/electronic equipment: upset and permanent damage. Upset is the temporary generation of false signals that cause the system to take undesired actions. Damage refers to the degradation of a component to the point where it can not perform its design function. Both safety and reliability problems can result from either type of response.

F2.7.4.3 Other areas of concern. As subsystems are assembled into a complete operating system, their susceptibility to HEMP can change dramatically due to changes in effective shielding and size of the inadvertent antenna system exposed to HEMP. HEMP tests should, therefore, include evaluation of the vulnerability of the fuze in all of its significant system configurations. Where called for, tests should include munition operational environments before, during, and after launch.

F2.7.5 Test applicability. Applicability is as follows:

MIL-STD-331C
w/CHANGE 1
APPENDIX F

a. The HEMP test is primarily a fuze test and need only be applied to those fuzes that contain electroexplosive devices or other electrical/electronic components. All fuzes should be safe and reliable following exposure to HEMP while they are in their storage and transportation configurations to ensure against a complete loss of capability of the stockpile in case of an HEMP event. If the fuze is also stored or transported while mounted on one or more munitions or outside its storage container, then these are appropriate test configurations. These tests will not evaluate electronic system upset, since this normally requires the electronic circuits to be activated, a condition that will not exist in transportation and storage configurations. All these tests are the responsibility of the fuze developer.

b. A statement, similar to a. above, can be made for the munition without fuze attached. Although these tests are normally the responsibility of the munition developers, test F2 may be used in the absence of a specific HEMP test for unfuzed munitions.

c. In general, for a munition, the configuration most susceptible to HEMP occurs during preparations for launch. At this time, cables entering the munition, create antennas capable of capturing energy from electromagnetic fields. Also, the electronics and guidance system are activated. The second most susceptible configuration is the munition in flight, again because the electronics are activated, the fuze may be armed, and there may be an electrically conductive exhaust plume adding to the inadvertent antenna systems and increasing the chances for a fuze premature or malfunction. Not all munitions are required to be safe from HEMP under these conditions, because of practicality limitations.

d. For those munitions or weapon systems for which HEMP survivability is essential to mission success or platform safety, HEMP vulnerability tests are required. These tests should be conducted in all significant munition/weapon systems handling configurations to evaluate effects on EEDs, electronic system damage and upset on all components in the system, including those in the fuze. Test F2 does not necessarily apply to complete system tests and responsibility normally lies with the munition weapon developer.

F2.7.6 Bibliography.

F2.7.6.1 Defense Nuclear Agency EMP Handbook.

F2.7.6.1.1 DNA 2114H-1 (DDC AD 520718), Volume 1, Design Principles, November 1971 (CONFIDENTIAL).

F2.7.6.1.2 DNA 2114H-2 (DDC AD 520943), Volume 2, Analysis and Testing, November 1971 (CONFIDENTIAL).

F2.7.6.1.3 DNA 2114H-3, Volume 3, Environment and Application, May 1972 (SECRET-RESTRICTED DATA).

F2.7.6.1.4 DNA 2114H-4 (DDC AD 522310), Volume 4, Resources, November 1971 (CONFIDENTIAL).

F2.7.6.2 EMP, Engineering and Design Principles by R. Sherman, R. A. DeMoss, W. C. Freeman, G. J. Greco, D. G. Larson, L. Levy, and D. 5. Wilson, Bell Telephone Laboratories, 1975.

F2.7.6.3 Semiconductor and Non-conductor Damage Study, by D. C. Wunsch and L. Marsitelli. Braddock, Dunn and McDonald (EMD) Final Report, Vol. 1, April 1969.

F2.7.6.4 Determination of Threshold Failure Levels of Semiconductor Diodes and Transistors Due to Pulse Voltage, by D. C. Wunsch and R. R. Bell, IEEE Transactions on Nuclear Science, Vol. NS-15, December 1968, pp 244-259.

F2.7.6.5 DNA 2772T (ADA058367) DNA EMP Awareness Course Notes, Third Edition, Oct

1977, by I. N. Mindel, IIT Research Institute.

F2.7.6.6 DNA-H-86-68V2 (Contract No. DNA 001-81-C-0252) DNA EMP Course Study Guide, Volume II, May 1986, (Restricted) by P. Dittmar, et. al., BDM Corporation.

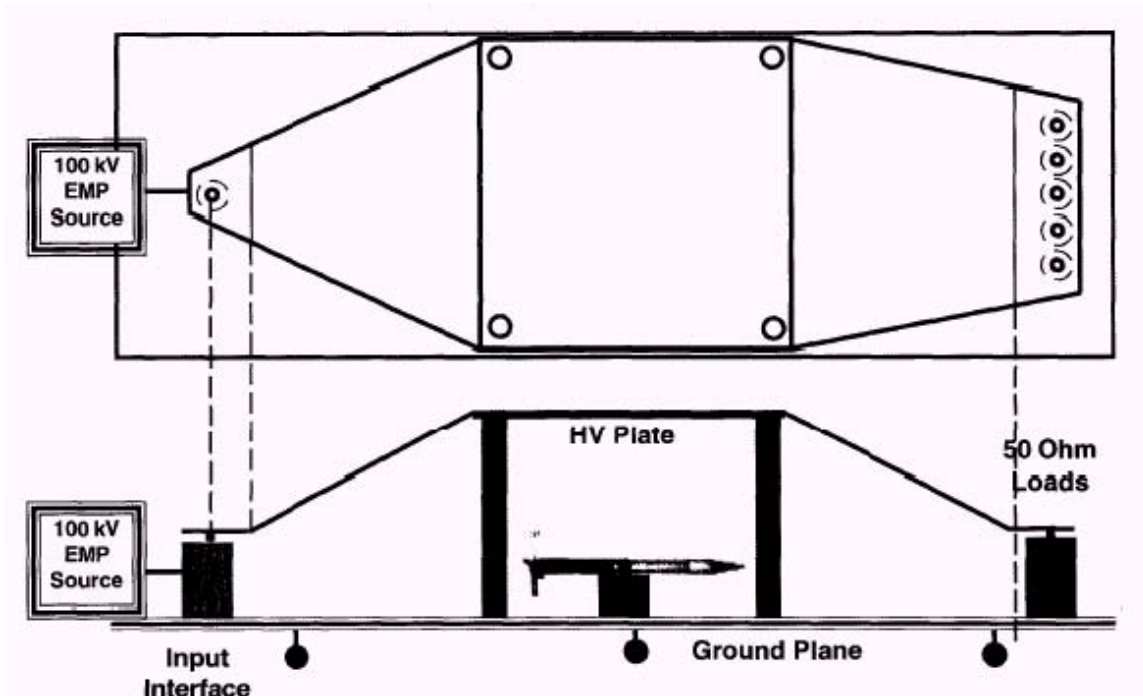

Figure F2-1. Bounded Wave Simulator

MIL-STD-331C
w/CHANGE 1
APPENDIX F

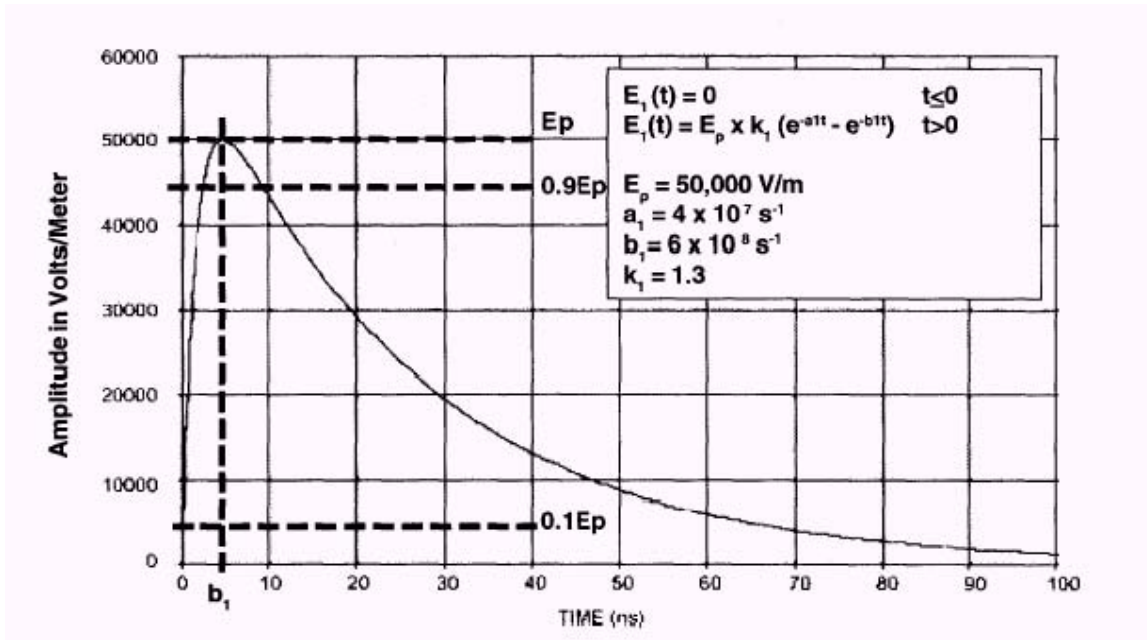

FIGURE F2-2. Characteristics of UNCLASSIFIED HEMP SIMULATOR

TEST F3

ELECTROMAGNETIC RADIATION HAZARDS (HERO)

F3.1 PURPOSE

This is a laboratory safety and reliability test simulating Electromagnetic Radiation (EMR) which may impinge upon the fuzes containing Electro-explosive Devices (EED's) during their life cycle. Fuze EED's must withstand the high levels of electromagnetic radiation which may be encountered during storage, transportation, handling, loading and launching.

F3.2.1 General. This test evaluates the effect of subjecting bare and packaged unarmed fuzes to high EMR environments. Bare fuzes are exposed to the EMR environment which they are expected to encounter during handling, loading and launching. Packaged fuzes are exposed to the EMR environment which they are expected to encounter during storage and transportation.

F3.2.1.1 Storage and transportation HERO test. This test shall be conducted on packaged fuzes to evaluate their safety and reliability during and after exposure to a high EMR environment while in storage and transportation.

F3.2.1.2 Handling, loading and launching HERO test. This test shall be conducted on bare fuzes to evaluate their safety and reliability when exposed to a high EMR field during handling, loading and launching.

F3.2.2 Storage and transportation EMR environment. Service requirements for storage and transportation EMR environments vary somewhat though MIL-STD-464 is generally accepted. Army procured items have an additional requirement to withstand a minimum of 200 Vrms/m at all frequencies.

F3.2.3 Fuze configuration. The fuzes shall be completely assembled except that lead and booster charges may be omitted to facilitate testing. If any explosive elements are removed, care should be exercised to preserve electromagnetic equivalency of the resulting configuration. All EED's shall be replaced with appropriate instrumentation to measure the effect of the EMR environment on the EED.

F3.2.4 Applicable publications. All standards, specifications, drawings, procedures and manuals which form a part of this test are listed in Section 2 of the introduction to this standard. Special attention is directed to MIL-HDBK-1512, MIL-STD-464, MIL-I-23659, TOP1-2-511, and ADS-37 which have specific applications.

F3.2.5 Number of test items. A single test item is sufficient for an instrumented HERO test. However, more than one may be required to facilitate instrumentation.

F3.2.6 Test documentation. Test plans, performance records, equipment, conditions, results, and analysis shall be documented in accordance with 4.8 of the general requirements to this standard. The following unique requirements also apply.

F3.2.6.1 Analyses. EMR coupling analyses shall be performed for all known storage, transportation, handling, loading and launch configurations for the fuze. The analyses should determine and provide the most significant life cycle configurations, test configurations and orientations; the type of fuze instrumentation to be used for the test; the determination of the parameters to be monitored; the expected stress levels and the 0.1% probability 95% confidence no-fire characteristics of all EED's.

F3.2.6.2 Test plan. The formulation of an appropriate test plan shall be based on the

MIL-STD-331C
w/CHANGE 1
APPENDIX F

analysis of F3.2.6.1. The test plan shall include:

- a. Identification of the fuze items to be tested at the applicable level of component integration (i.e., system, munition, fuze, subsystem, etc.), and the following pertinent information:
 - 1) The physical condition of the fuze items to be tested.
 - 2) The test points and supporting rationale for choices.
 - 3) A description of the instrumentation installed in the fuze for response measurements and the minimum sensitivity requirements to ensure the appropriate safety factors can be demonstrated in the test EMR environment.
 - 4) The specific data to be recorded.
 - 5) The method of operation and monitoring of the equipment.
- b. A description of the test facilities to be employed to include instrumentation and transmitter characteristics, environment measurement techniques, and calibration procedures.
- c. A description of the test environment including field intensity, polarization, frequency range, number of test frequencies, rationale for frequency selection, and any modulation characteristics employed.
- d. A description of how the test environment differs from the threat environment and the methodology for extrapolating the test results to those that would result by exposing the system to the threat environment.
- e. A description of the specific procedures to be utilized during the test including the configuration of the test items, their orientation(s) with respect to the test field, the length of time of each exposure to an EMR environment and the data recording procedure.

F3.2.6.3 Test report. The test report shall contain the analyses of F3.2.6.1; the test plan; and all the raw data, reduced data, results and conclusions resulting from the tests delineated in the test plan. In particular the test report shall provide:

- a. The responses of the EED instrumentation to the EMR environment.
- b. A statement of how the test environments were measured including the type of field probes used and placement of the probes with respect to the fuze tested.
- c. A detailed description of the instrumentation calibration procedures and complete calibration data for all sensors used to monitor EED responses.
- d. A description of how the actual test procedures differ from those in the test plan.
- e. A detailed description of how the raw data was analyzed and compared with EMR environment characteristics and EED no-fire characteristics to determine what safety factors were achieved.
- f. A summary of results to include a presentation of the worst case safety factors for each configuration tested. Graphical representation of the data is encouraged to increase the clarity of results.
- g. A statement of what conclusions can be drawn from the results regarding the safety and reliability of the fuze when exposed to the EMR environments to be encountered during its life cycle.

F3.3 CRITERIA FOR PASSING TEST

F3.3.1 Fuze condition. The fuze EED's must remain safe and reliable when exposed to the appropriate EMR environments to be encountered during storage, transportation, handling, loading, and launching.

F3.3.2 Decision basis. An analysis of the test data will form the basis for determining if the fuze has passed or failed this test. Data shall be analyzed for each configuration to determine if the following criteria is met:

MIL-STD-331C
w/CHANGE 1
APPENDIX F

- a. For EED's within fuzes configured in a manner that their premature function will cause the initiation of a main charge or removal of a safety feature, no more than the no-fire characteristics of that EED reduced by 16.5 dB shall be induced in it due to exposure to the specified EMR environment.
- b. For EED's within fuzes configured in a manner that their premature function will cause the munition to fail to function reliably, no more than the no-fire characteristics of that EED reduced by 6.9 dB shall be induced in it due to exposure to the specified EMR environment.

F3.4 EQUIPMENT

F3.4.1 Transmitter. The transmitting equipment used for the test must have sufficient stable power output over the EMR environment frequency range to ensure that appropriate safety factors can be verified. Frequency output should be controllable to within a nominal 2% of each desired test frequency. Laboratory transmitting equipment normally consists of a series of RF signal generators and wideband power amplifiers which amplify the output of the signal source to hundreds or thousands of watts. Some U.S. military test facilities have transmitting equipment with a peak power capability exceeding 100,000 watts.

F3.4.2 Antennas. Antennas used to perform EMRH testing must convert the output of the transmitting equipment to an electromagnetic field which is repeatable and reasonably uniform over the test volume. As a rule, at frequencies below 1 GHz, the field intensity over the test item volume should not vary by more than 6 dB. At frequencies over 1 GHz, this is commonly not practical and the item must be moved in the field to ensure that all cracks, seams, and other penetrations are fully illuminated with the specified EMR environment.

F3.4.3 Field measurements. The field intensity must be measured using appropriate field measurement techniques. Field measurements should be made using equipment with an absolute accuracy of at least 2 dB. Either of the following techniques may be used to ensure a calibrated field measurement.

F3.4.3.1 Direct field measurement prior to test. One method of measuring the field intensity applied to a test item is to measure the applied field at the test location with the test item absent. With a field meter at the test location, raise the transmitter output until the desired test field level is reached. Measure the actual power output of the transmitter using a directional coupler and power meter or some other technique capable of measuring high power level. Annotate the transmitter power which produces this field intensity at the test volume. For test objects of significant size, the field should be measured at various points within the test volume to assess the field uniformity. Continue this process for each frequency and polarization to be tested. During the test, set the transmitter output power to that level annotated during the calibration procedure.

F3.4.3.2 Relative field measurement prior to test. The field intensity applied to a test item may be determined based upon field intensity measurements made in the empty test volume prior to the test. With a field meter at the test location, raise the transmitter output until a predetermined field level is reached. Measure the actual power output of the transmitter using a directional coupler and power meter or some other technique capable of measuring high power level. Annotate the transmitter power which produces this field intensity at the test volume and calculate and record the total transmission system gain. For test objects of significant size, the field should be measured at various points within the test volume to assess the field uniformity. Continue this process for each frequency and polarization to be tested. During the test, the test field intensity can be calculated using the transmitter output power and the system gain. If using this method, care must be taken to ensure that all power measurement equipment is linear from

the calibration level through the test power level.

F3.4.3.3 Direct field measurement during test. The most direct approach to determining the field intensity on a fuze item is by placing field probes in the test volume during the test. In this way, field intensity can be measured directly during the test. If this method is used, care must be taken to ensure that the field measurement equipment does not interfere with the field significantly, the field probes are not interfered with by the test item (for example, there is an apparent field intensification near the ends of cylindrical objects), and that the field probes are close enough to the test item to closely approximate the field on the test item. As the requirements are somewhat conflicting, this method requires technical judgments to be made.

F3.4.4.1 Vacuum thermocouple instrumentation. This type of instrumentation utilizes a thermocouple mounted in close proximity to a bridgewire. The bridgewire and thermocouple are suspended in a vacuum to maintain temperature stability. The thermocouple, which is close enough to the bridgewire to respond to changes in its temperature, outputs a DC voltage proportional to the amount of energy dissipated in the bridgewire. These devices can be calibrated using DC current to determine the response to the rms current induced by RF. The technical challenge to be overcome with this type of instrumentation is to mount the sensor in place of the EED and get its DC output out of the fuze in a way that will not disturb the EMR characteristics of the fuze. The preferred method is through the use of fiber optics. The output of the thermocouple can be amplified and used to drive a Voltage Controlled Oscillator (VCO). The VCO output can then drive an LED which feeds the fiber optic output. In some instances, this instrumentation may not fit inside the fuze or munition. In those instances, the DC output of the thermocouples may be brought out of the fuze or munition to an instrumentation package using filtered feed through connectors and shielded twisted pair. Tests should be accomplished to ensure that the instrumentation external to the munition is not being interfered with by the EMR environment nor providing a significant additional antenna for the fuze.

F3.4.4.2 Fiber optic sensor instrumentation. There are some commercially available instruments designed specifically to overcome some of the pitfalls of EMRH testing of munitions. These make use of small current sensors with a direct fiber optic output. One technology makes use of a small dot of phosphor on the bridgewire. The decay time of the phosphor is proportional to its temperature. A fiber optic line is mounted in close proximity in order to illuminate the phosphor and subsequently to measure its decay time. The sensor can be calibrated for temperature rise vs. temperature. Another technology uses a small semiconductor device which responds to current. Bridgewire is run from the posts of an EED to this semiconductor circuit. A fiber optic is mounted to monitor the status of the semiconductor. A choice of fiber optic sensor technology will depend on the parameters being measured and the instrumentation sensitivity requirement for the test.

F3.5 PROCEDURE

The specifics of the test procedure will vary from test to test due to the uniqueness of the fuzes being tested. However, the basic procedure should closely resemble the following:

- a. Place the instrumented fuze in the test area in the configuration to be tested.
- b. Orient the fuze to the source antenna as prescribed in the test plan.
- c. Turn on the transmitter tuned to the frequency specified for test.
- d. Gradually increase the field intensity until either the specified EMR environment is reached or the instrumentation shows a response approaching its damage level.
- e. When applicable, perform any necessary actions on the test items (attaching cables in preparation for launch, etc.).

- f. Record the field level, frequency, polarization, test item orientation, configuration, and instrumentation response. If no response is detected by the instrumentation, record the minimum detectable level.
- g. Repeat steps a through f for all configurations, orientations, polarizations, and frequencies in the test plan.

F3.6 ALTERNATE AND OPTIONAL TESTS

None.

F3.7 RELATED INFORMATION

F3.7.1 Data analysis.

F3.7.1.1 Extrapolation. In many test facilities the fuze's EMR environment requirements cannot be generated over all frequency ranges. A commonly accepted practice is to measure the response of the EED's at the maximum field capability of the test facility and extrapolate those measurements to the specified field intensity. In order for this extrapolation to be valid the following requirements apply:

- a. The instrumentation must be sensitive enough so that its minimum detectable level when increased by the ratio of the required field to the test field is still less than the no-fire characteristics of the EED reduced by the appropriate safety factor from F3.3.2.
- b. There must be some reasonable evidence that the response of the system is linear in the region between that at which the measurements are made and that to which they are to be extrapolated.

If these two conditions are met, HERO test data can be gathered at levels readily available at most test facilities and extrapolated to high EMR specification levels.

F3.7.1.2 Data presentation format. There are two main methods of reducing, extrapolating, and presenting the results of EMRH tests. One involves the calculation of the highest field level at which the required safety factor (see F3.3.2) is maintained and comparing it to the EMR environment specification (see F3.2.2) for the item tested. The other method is used to calculate the safety factor obtained at the specified EMR environment and compare it to the required safety factor from F3.3.2.

F3.7.1.2.1 No-fire field intensity (NFFI) format. When data is calculated and presented in this format, the environment in which the item is safe and reliable is readily apparent. The No-fire field intensity is a calculated field intensity at which the current induced in the EED is equal to the no-fire characteristic of that EED reduced by the appropriate safety factor. The NFFI is calculated using the following equation:

$$NFFI = TFI \times SF \times NFL / ML$$

where:

NFFI = No-fire Field Intensity

TFI = Test Field Intensity

SF = Safety Factor (from F3.3.2) expressed as a decimal ratio

NFL = EED 0.1%, 95% confidence no-fire level (current or voltage)

ML = measured level (current or voltage). If no response is measured during testing use the minimum detectable level as ML

This method would be useful for a quick evaluation of a system if the required EMR environments were to change. It also lends itself extremely well to a graphical presentation of the data which shows the systems response with respect to frequency and with respect to the EMR environment specification in a manner clearly understandable by persons not familiar with this type of testing.

F3.7.1.2.2 Safety factor format. When data is calculated and presented in this format, the level of safety afforded at the EMR environment specification is readily apparent. The safety factor

MIL-STD-331C
w/CHANGE 1
APPENDIX F

afforded at the EMR environment specified is calculated using the following equation:

$$SF = (RFI \times ML) / (TFI \times NFL)$$

where:

SF = safety factor at the EMR environment specified

RFI = required field intensity

ML = measured level (current or voltage). If no response is measured during testing use the minimum detectable level as ML

NFL = EED 0.1%, 95% confidence no-fire level (current or voltage)

This method would be useful for a quick evaluation of a system if the safety factor requirements were to change for an EED for some reason. This method does not, however, lend itself to a graphical presentation of the data in a meaningful way.

F3.7.2 Electroexplosive devices (EED's). In order to perform an HERO test on a fuze, a basic understanding of different types of EED's is required so that instrumentation can be used which will measure the appropriate parameters and also so that data can be analyzed correctly. The following basic types of EED's are often found in fuzes and their peculiar characteristics should be understood by the test designer.

F3.7.2.1 Hot bridgewire devices. Perhaps the most common type of EED's in fuzes is the hot bridgewire. Most piston actuators and microdetonators are of this type. This type of EED has a small explosive charge mounted on a thin resistive bridgewire. When sufficient current passes through the bridgewire (either intentionally or unintentionally), the joule heating effect causes the charge to ignite. This, in turn, ignites the rest of the energetic material in the EED. These devices are normally initiated by a small voltage on a relatively large capacitor. For pulse modulated fields hot bridgewire devices respond to the average current level as opposed to the peak level unless sufficient energy is contained in a single pulse to initiate the device. The thermal time constant of the device should be considered with respect to the duty cycle and pulse repetition rate when evaluating a hot bridgewire device against a specific threat environment.

TEST F4
ELECTROMAGNETIC RADIATION, OPERATIONAL (EMRO)

F4.1 PURPOSE

This is a laboratory safety and reliability test simulating Electromagnetic Radiation (EMR) which may impinge upon the fuzes containing Electro-explosive Devices (EEDs) and electronics during their life cycle. Fuze electronics must withstand the high levels of electromagnetic radiation which may be encountered during storage, transportation, handling, loading, launching and travel to target.

F4.2 DESCRIPTION

F4.2.1 General. This test evaluates the effect of high EMR environments on the electronics of bare, operating fuzes. Bare fuzes are exposed to the tactical EMR environment which they are expected to encounter from the time power is normally applied to the point of function. Bare fuzes with non-interrupted explosive trains are additionally exposed to the EMR environment which they are expected to encounter during storage and transportation with inadvertent power applied.

F4.2.1.1 Handling, loading and launching EMRO test. This test shall be conducted on all bare fuzes to evaluate their safety and reliability when exposed to a high EMR field during handling, loading, launching and functioning.

F4.2.1.2 Storage and transportation EMRO test. This test shall be conducted on fuzes with non-interrupted explosive trains to evaluate their safety and reliability during and after exposure to a high EMR environment associated with storage and transportation. Power is applied to simulate the inadvertent application of power while in this environment. This test is performed without protective packaging as a worst-case test of the robustness of the electronics.

F4.2.2 Electromagnetic environments.

F4.2.2.1 Handling, loading and launching EMR environment. The handling, loading and launching EMR environments are considered to be those which are defined in the specification for the munition. See Table F4-I.

TABLE F4-1: Army Electromagnetic Radiation Environment During Handling, Loading and Launching of Munitions			
Frequency (MHz)	Electric Field (Vrms/m)		Polarization
	Average	Peak	
0.1 - 2	50	100	Vertical
2 - 32	100	200	Vertical
32 - 100	100	200	Vertical and Horizontal
100 - 1000	200	400	Vertical and Horizontal
1000 - 18000	200	20,000*	Vertical and Horizontal
* Design Goal, Not a Test Requirement			

F4.2.2.2 Storage and transportation EMR environment. The minimum storage and transportation test environment is considered to be 200 Vrms/m from 100 kHz to 40 GHz.

F4.2.3 Fuze configuration. The fuzes shall be completely assembled except that lead and booster charges may be omitted to facilitate testing. If any explosive elements are removed, care

MIL-STD-331C
w/CHANGE 1
APPENDIX F

should be exercised to preserve electromagnetic equivalency of the resulting configuration. All EEDs shall be replaced with appropriate instrumentation to monitor the functioning of the electronic subsystems. For fuzes with non-interrupted explosive trains, instrumentation shall be installed to measure the voltage generated on firing capacitors during the test. For fuzes with non-interrupted explosive trains, testing shall be performed with tactical cables/lengths, representative grounding, and simulated loads at cable end. System level tests shall include the full up system with all cables and other electronics.

F4.2.4 Applicable publications. All standards, specifications, drawings, procedures and manuals which form a part of this test are listed in Section 2 of the introduction to this standard. Special attention is directed to MIL-STD-464, MIL-I-23659, TOP 1-2-511 and ADS-37 which have specific applications.

F4.2.5 Number of test items. A single test item is sufficient for an instrumented EMRO test. However, more than one may be required to facilitate instrumentation or to gain knowledge of round to round variations in hardness levels.

F4.2.6 Test documentation. Test plans, performance records, equipment, conditions, results, and analysis shall be documented in accordance with 4.8 of the general requirements to this standard. The following unique requirements also apply:

F4.2.6.1 Analyses. EMR coupling analyses shall be performed for all known storage, transportation, and handling configurations for the fuze. The analyses should determine and identify the most significant life cycle configurations, test configurations and orientations; the type of fuze instrumentation to be used for the test and the parameters to be monitored. The analyses should also determine what specific modulation types and frequencies are most likely to have an adverse effect on the fuze electronics and must include pulse modulation at the transformer charging frequency for fuzes with non-interrupted explosive trains (see F4.7.2).

F4.2.6.2 Test plan. The formulation of an appropriate test plan shall be based on the analyses of F4.2.6.1. The test plan shall include:

- a. Identification of the fuze items to be tested at the applicable level of component integration (i.e., system, munition, fuze, subsystem, etc), and the following pertinent information:
 - (1) The physical condition of the fuze items to be tested.
 - (2) The test points and supporting rationale for choices.
 - (3) A description of the instrumentation installed in the fuze for response measurements and the minimum sensitivity requirements to ensure the appropriate safety factors can be demonstrated in the test EMR environment when applicable.
 - (4) The specific data to be recorded.
- b. A description of the test facilities to be employed to include instrumentation and transmitter characteristics, environment measurement techniques, and calibration procedures.
- c. A description of the test environment including field intensity, polarization, frequency range, number of test frequencies, rationale for frequency selection, and any modulation characteristics employed. Swept frequency testing is encouraged to identify resonance points for follow-on discrete frequency testing. Note that for discrete frequency tests, no fewer than the minimum number of frequencies per band specified in Table F4-II should be selected. Testing should be accomplished from the frequency at which the maximum dimension of the test item (i.e., launcher including host vehicle, munition, fuze, subsystem, etc.) is 1/4 wavelength to 40 GHz (or the maximum available at the test facility, if at least 18 GHz).

MIL-STD-331C
w/CHANGE 1
APPENDIX F

Table F4-II. Minimum Number of Test Frequencies for Discrete Frequency Testing

Frequency Range (MHz)	Minimum Number of Test Frequencies
0.01 - 2	10
2 - 32	20
32 - 100	20
100 - 1,000	10
1,000 - 18,000	20
18,000 - 40,000	5

- d. A description of how the test environment differs from the threat environment and the methodology for extrapolating the test results to those that would result by exposing the system to the threat environment.
- e. A description of the specific procedures to be utilized during the test including the configuration of the test items, their orientation(s) with respect to the test field, the detailed procedure used to operate the fuze, the length of time of each exposure to an EMR environment and the data recording procedure.

F4.2.6.3 Test report. The test report shall contain the analyses of F4.2.6.1; the test plan; and all the raw data, reduced data, results and conclusions resulting from the tests delineated in the test plan. In particular the test report shall provide:

- a. For fuzes with non-interrupted explosive trains:
 - (1) A detailed description of the instrumentation calibration procedures and complete calibration data for all sensors used to monitor current and voltage levels.
 - (2) A detailed description of how the raw data was analyzed and compared with EMR environment characteristics and firing capacitor voltage limits to determine what safety factors were achieved.
- b. For all fuzes:
 - (1) The responses of the instrumentation with the fuze in the EMR environment.
 - (2) A statement of how the test environments were measured including the type of field probes used and placement of the probes with respect to the fuze tested.
 - (3) A description of how the actual test procedures differed from those in the test plan.
 - (4) A statement of what conclusions can be drawn from the results regarding the safety and reliability of the fuze when exposed to the EMR environments to be encountered during its life cycle.

F4.3 CRITERIA FOR PASSING TEST

F4.3.1 Fuze condition. Fuzes with non-interrupted explosive trains must remain in a safe condition when exposed to worst-case storage and transportation EMR environments with power applied to electronics. All fuzes must operate reliably in their tactical EMR environment.

F4.3.2 Decision basis. An analysis of the test data will form the basis for determining if the fuze has passed or failed this test. Data shall be analyzed for each configuration to determine if the following criteria are met:

MIL-STD-331C
w/CHANGE 1
APPENDIX F

- a. For fuzes with non-interrupted explosive trains, no more than 75 Volts (after extrapolation from the test field intensity levels to the levels specified in MIL-STD-464) is permitted to be generated on the firing capacitors prior to the point of intentional charging.
- b. The electronics of all fuzes must operate reliably and function normally when exposed to the tactical EMR environment specified for the system.

F4.4 EQUIPMENT

F4.4.1 Transmitter. The transmitting equipment used for the test must have sufficient stable power output over the EMR environment frequency range to ensure that tactical field levels can be maintained for the duration of the test. Transmitting equipment used for testing fuzes with non-interrupted explosive trains should be able to generate 200 V/m rms over the test frequency range. Frequency output should be controllable to within a nominal 2% of each desired test frequency. Laboratory transmitting equipment normally consists of a series of RF signal generators and wideband power amplifiers which amplify the output of the signal source to hundreds or thousands of watts. Some U.S. military test facilities have transmitting equipment with a peak power capability exceeding 100,000 watts.

F4.4.2 Antennas. Antennas used to perform EMRO testing must convert the output of the transmitting equipment to an electromagnetic field which is repeatable and reasonably uniform over the test volume. As a rule, at frequencies below 1 GHz, the field intensity over the test item volume should not vary by more than 6 dB. At frequencies over 1 GHz, this is commonly not practical and the item must be moved in the field to ensure that all cracks, seams, and other penetrations are fully illuminated with the specified EMR environment.

F4.4.3 Field measurements. The field intensity must be measured using appropriate field measurement techniques. Field measurements should be made using equipment with an absolute accuracy of at least 2 dB. Any of the following techniques may be used to ensure a calibrated field measurement.

F4.4.3.1 Direct field measurement prior to test. One method of measuring the field intensity applied to a test item is to measure the applied field at the test location with the test item absent. With a field meter at the test location, raise the transmitter output until the desired test field level is reached. Measure the actual power output of the transmitter using a directional coupler and power meter or some other technique capable of measuring high power level. Annotate the transmitter power which produces this field intensity at the test volume. For test objects of significant size, the field should be measured at various points within the test volume to assess the field uniformity. Continue this process for each frequency and polarization to be tested. During the test, set the transmitter output power to that level annotated during the calibration procedure.

F4.4.3.2 Relative field measurement prior to test. This method is generally used when testing is to be accomplished at more than one field intensity level or when the test field level is beyond the dynamic range of the field measurement equipment. The field intensity applied to a test item may be determined based upon field intensity measurements made in the empty test volume prior to the test. With a field meter at the test location, raise the transmitter output until a predetermined field level is reached. Measure the actual power output of the transmitter using a directional coupler and power meter or some other technique capable of measuring high power level. Annotate the transmitter power which produces this field intensity at the test volume and calculate and record the total transmission system gain. For test objects of significant size, the field should be measured at various points within the test volume to assess the field uniformity. Continue this process for each frequency and polarization to be tested. During the test, the test

field intensity can be calculated using the transmitter output power and the system gain. If using this method, care must be taken to ensure that all power measurement equipment is linear from the calibration level through the test power level.

F4.4.3.3 Direct field measurement during test. The most direct approach to determining the field intensity on a fuze item is by placing field probes in the test volume during the test. In this way, field intensity can be measured directly during the test. If this method is used, care must be taken to ensure that the field measurement equipment does not interfere with the field significantly, the field probes are not interfered with by the test item (for example, there is an apparent field intensification near the ends of cylindrical objects), and that the field probes are close enough to the test item to closely approximate the field on the test item. As the requirements are somewhat conflicting, this method requires technical judgments to be made. Due to the difficulty in obtaining repeatable, accurate measurements with this method, it should be avoided if at all possible.

F4.4.4 Fuze instrumentation. The fuze being tested must be instrumented to monitor the functioning of the electronics during the test. Additionally, fuzes with non-interrupted explosive trains must have instrumentation to measure the voltage buildup on the firing capacitors during the test. Care must be taken when instrumenting a fuze so that the instrumentation provides an accurate measure of voltage or other response without significantly affecting the result. The primary concerns are that the shielding integrity of the fuze not be altered by the instrumentation and that the instrumentation not form an additional inadvertent antenna with different characteristics than that of the fuze electronic circuits. Some method of monitoring the electrical signals within the fuze/munition using fiber optics is used almost exclusively in order to achieve these goals. Some acceptable instrumentation methods which can be used to monitor current pulses are explained in Test F3.1 of this standard. Specific instrumentation for any fuze EMRO test will by nature be quite unique.

F4.4.5 Ancillary equipment. Almost always, some additional electronic equipment will be required in order to test the functioning of the fuze in operational configurations. Many fuzes require a switch closure (accomplished tactically by launch-related setback or spin forces) and/or other physical/electrical/electromagnetic stimuli to simulate the normal operation of the fuze from launch to the point of intended function during testing. Care should be taken in the design of this special purpose circuitry that the electromagnetic properties of the fuze are not altered.

F4.5 PROCEDURE

The specifics of the test procedure will vary from test to test due to the uniqueness of the fuzes being tested. However, the basic procedures should closely resemble the following:

- a. Place the instrumented fuze in the test area in the configuration to be tested.
- b. Orient the fuze to the source antenna as prescribed in the test plan.
- c. Turn on the transmitter tuned to the frequency and modulation specified for test.
- d. Gradually increase the field intensity until either the specified EMR environment is reached or the fuze demonstrates an undesirable response.
- e. When applicable, perform any necessary actions on the test items (apply power, close spin switch, close crush switch, apply acceleration profile, etc.).
- f. Record the field level, frequency, polarization, test item orientation, configuration, and whether the fuze operated properly. For non-interrupted explosive trains, record the highest voltage measured on the firing capacitors prior to intentional charging. If no voltage is detected by the instrumentation, record the minimum detectable level.
- g. Repeat steps a through f for all configurations, orientations, polarizations, and frequencies in the test plan.

Note that for testing non-interrupted explosive trains in the shipping and storage configuration with power applied to the electronics, the fuze should be exposed to the field during each trial for at least 30 seconds. Alternately, if swept frequency testing is used, the sweep rate should not exceed 120 seconds per octave. If there is a measurable system response that continues to increase during field exposure, the exposure time should be increased (or the sweep rate decreased, as appropriate) until the maximum system response has been obtained.

F4.6 ALTERNATE AND OPTIONAL TESTS

None

F4.7 RELATED INFORMATION

F4.7.1 Data analysis

F4.7.1.1 Handling, loading and launching testing of all fuzes. Fuze functioning information when exposed to the specified EMR environment should be recorded and compared with the fuze's normal functioning to determine if safety and reliability have been affected.

F4.7.1.2 Shipping and storage testing of fuzes with non-interrupted explosive trains. Voltages measured on the firing capacitors when exposed to the 200 V/m test environment should be extrapolated to the MIL-STD-464 field levels. The fuze is considered safe if less than 75 volts is obtained under these circumstances. See F4.7.3 for a discussion of the validity of this extrapolation.

F4.7.2 Background for non-interrupted explosive train test requirements.

Traditionally, fuzes have contained a physical barrier between the primary and secondary explosives. The intent of the barrier was to prevent an inadvertent functioning of the initiator from propagating to the main charge. This was proven out through a series of explosive tests which demonstrate the effectiveness of the barrier to interrupt the explosive train with a high degree of confidence. In general, this physical barrier, together with two independent locks on the barrier provided a level of safety of better than one in a million.

F4.7.2.1 More recently a new concept in fuzing has emerged which holds promise to greatly improve the operational effectiveness and reliability of many weapons systems. Fuzes with non-interrupted explosive trains typically contain few or no moving parts and, as a rule, no physical barrier in the explosive train between the initiator and the main charge. This is made possible through the use of initiators that contain only secondary explosives. Specific controls have been written into the fuze safety design standard, MIL-STD-1316, which if adhered to should provide at least the same degree of safety as traditional S&As which incorporate explosive train interruption. The key safety concern of fuzes with non-interrupted explosive trains is that unintended functioning of the initiator would cause the main charge to detonate. The safety of fuzes with non-interrupted explosive trains rests on a very high degree of confidence that the initiator will not function except when intended as opposed to the traditional S&A where the safety is based on the effectiveness of a mechanical interrupter and its locks.

F4.7.2.2 Certain design principles help to ensure that the initiator will not fire inadvertently in fuzes with non-interrupted explosive trains. Firstly, the initiator must not be capable of being fired with less than 500 Volts. This, in itself, makes it unlikely that the initiator would function due to stray electrical signals. Secondly, there are requirements for the design to incorporate interrupters to the electrical energy which could arm and fire the fuze. Additionally, it is required that one of these interrupters be dynamic in nature so that no combination of static failures could cause the fuze to fail into an unsafe state. For example, Figure F4-1 shows two static switches (closed when launch acceleration has been sensed and when the flight motor ignition has been sensed respectively) and one dynamic switch (activated upon determining that safe separation

distance has been achieved) which are all required to be enabled in order for electrical energy to accumulate in the firing capacitor.

F4.7.2.3 Electronic controls have increased vulnerability to electrical environments during an operational state. Weapons are operated today in uniquely hazardous electromagnetic environments. Typically, the worst electrical environment is shipboard, but experience with aircraft such as helicopters have shown the importance of designing to the severe EMR environments for many applications. Munitions that are operated on the deck of a ship; fired, dispensed, or launched from aircraft; or used in close support of sites with radar or other EMR sources typically have a need to be safe and reliable within the very high EMR environments.

F4.7.2.4 In a mechanical S&A, the safety system failure mechanisms are closely related to the effectiveness of the barrier and the reliability of its locks preventing the barrier from being removed prior to intentional arming. In fuzes with non-interrupted explosive trains, the failure mechanisms are related to the effectiveness of the electrical energy interrupters in preventing firing energy from being produced in the firing capacitor. In the example diagram, the chief concerns would be that the static and dynamic switches controlled by flight motor initiation, launch acceleration, and achievement of safe separation distance could be inadvertently controlled by some other influence. Also of concern is whether high voltage and/or current levels can be achieved at the firing capacitor or initiator regardless of the operation of the switches. The most likely environments to cause any of these failure mechanisms are Electromagnetic Environmental Effects (E^3). It is critical that Fuzes with non-interrupted explosive trains be designed to be immune to unsafe upset due to E^3 just as mechanical S&As are designed to withstand jolt, jumble, drop, etc.

F4.7.2.5 Tests are routinely done on a mechanical S&A which prove out its effectiveness with one of its safety features subverted in the presence of credible harsh mechanical and environmental stimuli. In the same way, ESAD's must be tested with applicable harsh environments with subverted safety features. As stated earlier, the most significant environments for fuzes with non-interrupted explosive trains are E^3 (e.g., ESD, EMR, Lightning...). It must be assumed for the purpose of safety analysis that power will be inadvertently applied to fuzes with non-interrupted explosive trains during shipping and storage or some other time prior to intentional functioning of the fuze. This may be considered either a subverted safety or a credible environment but it must be considered and incorporated into the fuze's Safety test program. The unique test requirements for non-interrupted explosive trains are intended to address these issues.

F4.7.2.6 The requirement for no more than 75 Volts on the capacitor was derived from 15% (the MIL-STD-464 safety factor) of the 500 Volts minimum firing voltage required by MIL-STD-1316. It is understood that this is very conservative for many initiators which have no-fire values significantly in excess of the 500 Volt minimum requirement. However as the 75 Volt requirement is readily achievable, it was chosen as a consistent requirement, avoiding the potential confusion associated with setting different requirements for each fuze.

F4.7.3 Validity of extrapolated EMRO data. EMRH data (see test F3) is normally extrapolated from a lower test field level to a higher criterion field level. This is quite valid in most instances provided that the instrumentation used had sufficient sensitivity and the measured data can be reasonably expected to be linear over the extrapolated frequency range. EMRO data, however, is normally never extrapolated. The primary reason is that EMRO tests are run on active electronics circuits which are, by their very nature, non-linear, thus invalidating the extrapolation process. For this reason, all EMRO tests must be done at the tactical field levels.

F4.7.3.1 Limited extrapolation is permitted for the shipping and storage EMRO test of fuzes with non-interrupted explosive trains for the following reasons: 1) The MIL-STD-464 field levels are

MIL-STD-331C
w/CHANGE 1
APPENDIX F

considered a credible but improbable environment to be encountered during a munition's life cycle, 2) Most test facilities cannot generate the field levels specified by MIL-STD-464, and 3) Although this extrapolation is not entirely technically correct, the net effect is to further limit the voltage level permitted on the firing capacitors at the test field level thus adding some additional measure of safety.

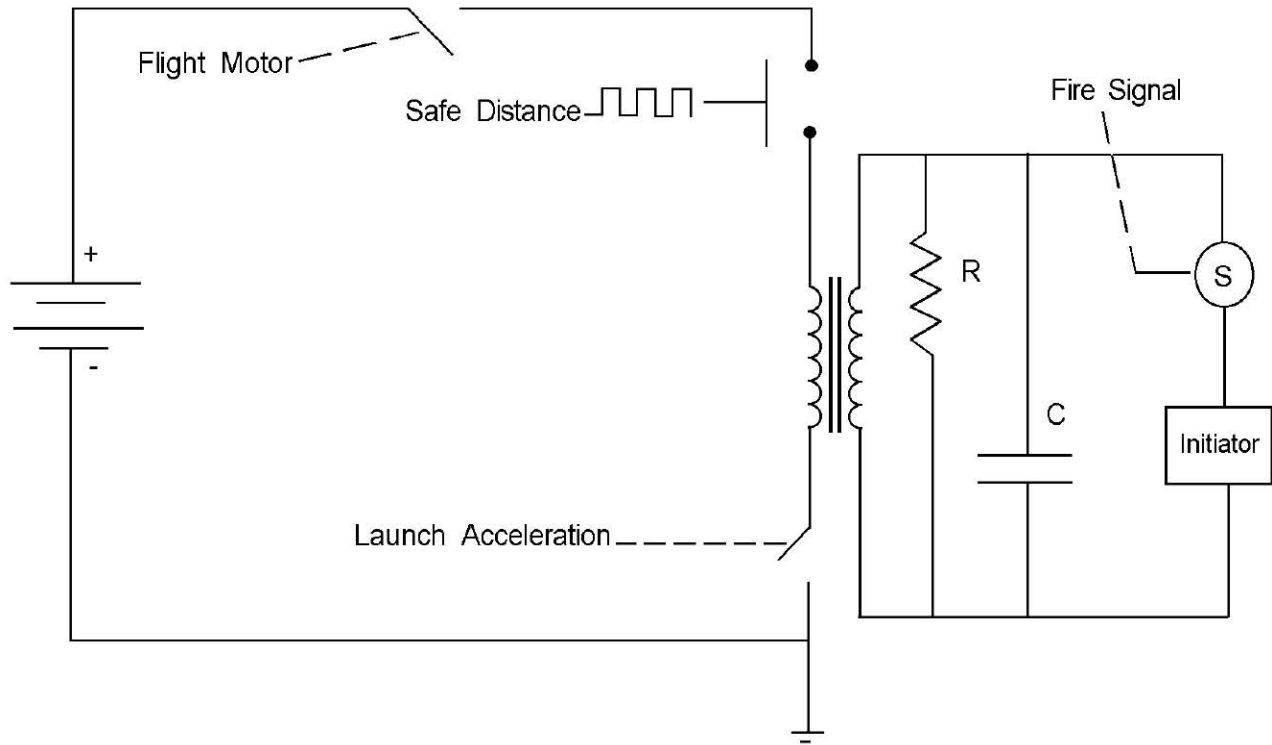

FIGURE F4-1. Simplified Block Diagram of a Fuze With a Non-Interrupted Explosive Train

APPENDIX G
STATISTICAL METHODS TO DETERMINE THE INITIATION PROBABILITY OF
ONE-SHOT DEVICES

G1 PURPOSE

The purpose of this Appendix is to provide statistical methods that can be used to determine the activation probability of a one-shot device as a function of an applied stimulus. Testing using these methods is often called sensitivity testing.

G2 DESCRIPTION

G2.1 General. A number of different sensitivity test methods have been proposed over the years. All of the methods are based on the assumption that the underlying population was distributed normally. All of the methods have been designed to estimate the normal distribution parameters (mean and standard deviation), and then to use these estimates to determine other population parameters, such as the level at which 99.9% or 1 in one million of the devices will function. All of these methods are capable of generating reliable estimates of the population parameters, although the efficiency of the methods varies widely. There are five methods presented: Probit, Langlie, One-shot transformed response (OSTR), Bruceton, and Neyer D-Optimal.

These sensitivity test methods all entail subjecting a sample of items to various stimulus levels, one at a time, with the stimulus levels selected based on experimental parameters and the results of items previously tested. For each test, the outcome is limited to one of two results, either a response (e.g. fuze armed, explosive transfer, detonation) or no response. These stimulus levels are chosen in the region of mixed response, i.e. the stimulus levels that have non-negligible probability of both responding and not responding. It is important to choose the stimulus levels with care. Tests conducted at stimulus levels that have essentially zero probability of responding or not responding contribute little knowledge about the device characteristics.

These methods can be used to determine the required barrier thickness as specified in test D1, to determine the fuze arming distance as specified in test D2, the rain impact sensitivity as specified in test D5, and the position of the explosive train interrupter as specified in test D8. These methods can also be used to determine the threshold current or voltage for detonator functioning or other similar characteristics.

If the response of the device (output, time to function, etc.) depends in a well characterized function on the initiation stimulus, then this test should not be used. In such cases, the device could be better characterized by measuring the responses of a sample, and using the response measurement to determine the threshold initiation stimulus.

G2.2 Documentation. In addition to the general requirements for test documentation specified in 4.8 of this standard, the raw test data (response or nonresponse and the stimulus level for each test) shall be reported along with the analyzed results (mean, standard deviation, no-fire or all-fire levels) to provide for independent analysis.

G3 METHODS

G3.1 Probit Method. Refer to G5.1, G5.2, G5.7 and G5.8 for background on this method.

G3.1.1 Probit features.

- a. Designed to estimate the entire response curve or any portion thereof.
- b. It is assumed that the probability of a response versus stimulus level is described by a cumulative, normal distribution.

MIL-STD-331C
w/CHANGE 1
APPENDIX G

- c. Stimulus levels are normally chosen in advance. Therefore, subsequent trials do not depend on previous results, and no constant step size is required. Test levels can be added or deleted if previous results are so indicated.
- d. Deviations about any given stimulus level must be held within a tight range.
- e. The number of trials required is usually larger than that of the other methods.
- f. The test method is less complex than that of the other methods.
- g. The quality of the fit between the observed results and the assumed distribution can be readily illustrated in the vicinity of the mean.
- h. The estimate of the mean is unbiased for practical purposes.
- i. The estimate of the standard deviation is biased to the low side.
- j. The need to use a computer program to implement the analysis calculations will depend on the type of analysis procedure selected. If the commonly used maximum likelihood estimates, for example, are employed, a computer program would be necessary.

G3.1.2 Probit procedure.

- a. Select the stimulus levels and the number of trials to be conducted at each stimulus level. The same number of trials at each stimulus level is not necessary. The stimulus levels chosen should concentrate about the percentile being estimated and cover the range of stimuli giving approximately 0 to 0.5 probability when estimating a low percentile, 0.5 to approximately 1.0 probability when estimating a high percentile, or approximately 0.25 to 0.75 probability when estimating the mean.
- b. At each stimulus level, conduct the required number of trials and record the results.

Example: The specification for a fuze under development states that the safe arming distance shall be no less than 10 meters. Fifty fuzes are available for this test. Chosen distances from muzzle to target at which to fire are 8, 10, 12, 15, and 20 meters, firing 10 rounds at each distance.

Stimulus Level (m)	Number of Trials	Resulting Number of Functions on Plate
8	10	0
10	10	1
12	10	2
15	10	6
20	10	5

The region of interest in this example is the lower tail of the response distribution (i.e., below the mean). The test produced 28 that armed (out of 100 tested), so the test was conducted (to some extent) in the region of interest. As a general rule, probability estimates will be most reliable over the region where the test was actually conducted, and will be less reliable elsewhere. However, for extreme probabilities it is not practical to test in the region of interest.

G3.1.3 Probit analysis. The stimuli and results are used to calculate maximum likelihood estimates of the mean and standard deviation of a normal distribution. It is assumed that the probability of response versus stimulus is described by a cumulative, normal distribution. A computer program is necessary to implement the computations. For the example problem

presented, the resulting estimates and probability of arming graph are given by Figure G9-1.

G3.2 Langlie Method. Refer to G5.3 for background information.

G3.2.1 Langlie features.

- a. Designed to estimate the stimulus for which there is a 0.5 probability of response.
- b. Because of concentration of testing at the mean, this technique is not effective at estimating probabilities at either extreme of the stimulus/response curve and should not be used for that purpose if other methods are useable.
- c. It is assumed that the probability of a response versus stimulus level is described by a cumulative normal distribution.
- d. Subsequent stimulus levels depend on previous test results.
- e. Step sizes are variable.
- f. Number of trials required is usually smaller than that of Probit, OSTR, and Bruceton tests.
- g. Test method is more complex than Probit and Bruceton tests.
- h. The estimate of the mean is unbiased for practical purposes.
- i. The estimate of the standard deviation is biased, but a bias correction can be applied if the Langlie method is rigorously followed.
- j. The need to use a computer program to implement the analysis calculations depend on the type of analysis procedure selected. If the commonly used maximum likelihood estimates, for example, are employed, a computer program would be necessary.
- k. The test equipment must be capable of covering the entire, continuous range of stimuli.
- l. Upper and lower test limits must be chosen prior to testing.
- m. If the time or effort required to obtain the information from the previous trial is excessive, this method may not be appropriate.
- n. Once the next stimulus level is determined, if the method requires too much time and difficulty to prepare the test item/apparatus for that trial, the method may not be appropriate.
- o. A stopping rule is required.

G3.2.2 Langlie procedure.

- a. Select the upper and lower test limits so that it is certain that there will be all nonresponses at the lower limit and all responses at the upper limit. Setting the limits to be approximately four standard deviations from the mean produces the best results. Call these stimuli U and L.
- b. A stopping rule is selected. It is recommended that at least 20 trials or 5 reversals with a zone of mixed results be used unless an alternate stopping rule was previously agreed to by the sponsoring activity.
- c. The first trial is conducted at a stimulus equal to the average of U and L.
- d. For the remaining trials the general rule is: The $(K+1)^{\text{st}}$ stimulus is equal to the average of the K^{th} stimulus and, counting backwards through the results, the stimulus whose result was such that there is an equal number of responses and nonresponses over that interval of trials. If this is not possible, average the K^{th} stimulus and U or L, as appropriate. Use U if the K^{th} result was a nonresponse and L if the K^{th} result was a response.

Example: A test to estimate the probability of arming versus distance from muzzle to target is to be conducted for Fuze XMPDQ. The developer claims that the fuze will be armed at 80 meters from the muzzle.

- Step 1. Choose the test limits. Let U = 100 meters (in case 80 meters is optimistic). Let L = 0 meters for the purpose of this example.

MIL-STD-331C
w/CHANGE 1
APPENDIX G

- Step 2. Choose the stopping rule. Conduct 20 trials.
Step 3. Conduct the first trial at $(U+L)/2 = 50$ meters.
Step 4. Select the remaining trials.

Trial No. (K)	Distance (Meters)	Result*	Remarks
1	$1/2(100+0)=50$	NF	For next stimulus, must average upper limit and 50 because there was not an equal number of responses and nonresponses.
2	$1/2(50+100)=75$	F	Stimuli for trials 1 and 2 can be averaged because there was reversal.
3	$1/2(75+50)=62.5$	F	Must average 62.5 with lower limit because there was not an equal number of responses and nonresponses.
4	$1/2(62.5+0)=31.25$	NF	Reversal, therefore, must average last two stimuli.
5	$1/2(31.25+62.5)=46.88$	F	Reversal, therefore, average last two stimuli.
6	$1/2(46.88+31.25)=39.06$	F	Must average 39.06 with lower limit because there was not an equal number of responses and nonresponses.
7	$1/2(39.06+0)=19.53$	NF	Reversal, therefore, average last two stimuli.
8	$1/2(19.53+39.06)=29.30$	NF	The 5th through 8th trials gave two responses and two nonresponses. Therefore, average 5th and 8th trials.
9	$1/2(29.30+46.88)=38.09$	NF	The 2nd through 9th trials gave four responses and four nonresponses.
10	$1/2(38.09+75.00)=56.54$	F	Reversal, therefore, average last two stimuli.
11	$1/2(56.54+38.09)=47.32$	F	The 8th through 11th trials gave two responses and two nonresponses. Therefore, average 8th and 11th trials.
12	$1/2(47.32+29.30)=38.31$	NF	

* F = Function; NF = Nonfunction

The remaining eight trials are determined in a similar manner.

Note, at any stage, the most recent stimulus is always used in averaging. Finding the stimulus with which the most recent stimulus is averaged is the only tricky part of the strategy.

MIL-STD-331C
w/CHANGE 1
APPENDIX G

The results necessary for analysis may be summarized:

Trial No.	Distance(m)	Result
1	50.00	NF
2	75.00	F
3	62.50	F
4	31.25	NF
5	46.88	F
6	39.06	F
7	19.53	NF
8	29.30	NF
9	38.09	NF
10	56.54	F
11	47.32	F
12	38.31	NF
13	42.82	NF
14	49.68	F
15	46.25	F
16	42.28	NF
17	44.26	F
18	43.27	F
19	31.40	NF
20	37.34	NF

G3.2.3 Langlie analysis. The stimuli and results are used to calculate the maximum likelihood estimates of the mean and standard deviation of a normal distribution. It is assumed that the probability of a response versus stimulus level is described by a cumulative normal distribution. A computer program is necessary to implement the computations. For the example problem, the resulting unbiased estimates and probability of arming graph are given in Figure G9-2.

G3.3 OSTR Method. Refer to G5.4 and G5.5 for further information.

G3.3.1 OSTR features.

- a. Designed to estimate an extreme percentile of response stimulus.
- b. It is assumed that the probability of a response versus stimulus level is described by a cumulative, normal distribution.
- c. Subsequent stimulus levels depend on previous results.
- d. Step sizes are variable.
- e. Number of trials required is usually larger than that of Langlie and Bruceton tests.
- f. One or more trials are conducted at a stimulus level prior to changing. (If only one trial is used at each stimulus, this reduces to the Langlie method.)
- g. The bias of the estimates of the mean and standard deviation has not been determined.
- h. Test method is more complex than the other methods.
- i. The need to use a computer program to implement the analysis calculations depends on the type of analysis procedure selected. If the commonly used maximum likelihood estimates are employed, for example, a computer program would be necessary. The program is given

in DARCOM-P706-103, Appendix 9B. Refer to G5.6.

- j. If obtaining the information from the previous trial requires too much effort and cost in order to determine the next stimulus level, this method may not be appropriate.
- k. Once the next stimulus is determined, if the method requires too much time and difficulty to prepare the test item/apparatus for that trial, the method may not be appropriate.
- l. Upper and lower test limits must be chosen prior to test.
- m. A stopping rule is required.
- n. The test equipment must be capable of covering the entire, continuous range of stimuli.

G3.3.2 OSTR procedure.

- a. Select the upper and lower test limits so that it is virtually certain that there will be all nonresponses at the lower limit and all responses at the upper limit. Call these stimuli U and L. Setting the limits to be approximately four standard deviations from the mean is expected to provide the best results.
- b. Select the percentage point to be estimated. See Tables G9-I and G9-II for upper and lower tails, respectively. Then use the corresponding maximum number of trials to be conducted at a given stimulus level prior to applying a change in stimulus level. The number of trials at a particular stimulus level depends upon the percentile estimated; further into the tail of the distribution will require more trials. For planning purposes, the expected number of total trials actually required is approximately three-fourths of the maximum number of trials at each stimulus level times the number of stimulus level.
- c. Establish the rule for increasing or decreasing the stimulus level. For example, suppose a lower-tail percentile with a corresponding maximum of three trials per stimulus level is chosen. The rule would be: Increase stimulus level if all three results in nonfunctioning; otherwise, decrease the stimulus level.
- d. Select a stopping rule. At least 5 reversals with a zone of mixed results, or at least 10 levels of stimuli, shall be used unless an alternate stopping rule was previously approved by the sponsoring activity. Occasionally, peculiar sequences of outcomes occur, that is, no zone of mixed results, which provide little or no information about the response distribution. This condition is minimized by using the change of response stopping rule rather than a fixed number of levels of stimuli. If upon stopping on number of reversals, a zone of mixed results has not occurred, the test procedures and goals should be examined to determine the possible cause of this anomaly. Additional trials will be required until a zone of mixed results is obtained.
- e. The first trial is conducted at the stimulus level equal to the average of U and L.
- f. Now follow the Langlie method of G3.2, except that more than one trial (up to the number selected in b above) will be conducted at a particular stimulus level. Note: When $n = 1$, the OSTR method becomes the Langlie.

Example: An arming distance test is to be conducted using a certain fuze. Thirty fuzes are available. Probability of arming versus distance from muzzle to target is assumed to be described by a cumulative, normal distribution. The no arm distance is to be estimated for safety reasons. The fuze is supposedly not armed at 10 meters.

MIL-STD-331C
w/CHANGE 1
APPENDIX G

An OSTR method plan is chosen:

A test is to be designed to determine the distance at which there is 0.21 probability of fuze function. Refer to Table G9-I. The corresponding maximum number of trials per stimulus level is three. The lower limit is chosen as 0 meters, and the upper limit is chosen as 40 meters. Rule: If three consecutive nonfunctions occur, increase the distance; if two consecutive nonfunctions followed by a function (NF, NF, F), or a nonfunction followed by a function (NF, F), or a function (F), decrease the distance. (It is assumed that if the fuze functioned, it was armed.)

Stimulus/Trial Level/No.	Distance Meters	Result*	Remarks
1 / 1	$(0+40)/2 = 20$	F	Decrease distance
2 / 1	$(20+0)/2 = 10$	NF	Decrease distance
2 / 2	10	NF	
2 / 3	10	F	
3 / 1	$(10+0)/2 = 5$	NF	Increase distance
3 / 2	5	NF	
3 / 3	5	NF	
4 / 1	$(5+10)/2 = 7.5$	NF	Increase distance
4 / 2	7.5	NF	
4 / 3	7.5	NF	
5 / 1	$(7.5+20)/2 = 13.75$	F	Decrease distance
6 / 1	$(13.75+7.5)/2 = 10.625$	NF	Decrease distance
6 / 2	10.625	F	
7 / 1	$(10.625+5)/2 = 7.812$	NF	Increase distance
7 / 2	7.812	NF	
7 / 3	7.812	NF	
8 / 1	$(7.812+10.625)/2 = 9.219$	NF	Increase distance
8 / 2	9.219	NF	
8 / 3	9.219	NF	
9 / 1	$(9.219+13.75)/2 = 11.484$	F	Decrease distance
10 / 1	$(11.484+9.219)/2 = 10.352$	F	Stopped on 10 levels

* F = Function; NF = Nonfunction

G3.3.3 OSTR analysis. The stimuli and results are used to calculate maximum likelihood estimates of the mean and standard deviation of a normal distribution. These estimates can be used to predict functioning probabilities at other distances. It is assumed that the probability of a response versus stimulus is described by a cumulative, normal distribution. A computer program is necessary to implement the computations. For the example presented, the resulting estimates and probability of arming graph are given in Figure G9-3.

G3.4 Bruceton Method. Refer to G5.9, G5.10 and G5.11 for further information.

G3.4.1 Bruceton features.

- a. Designed to estimate the stimulus at which there is a 0.5 probability of response.
- b. Because of concentration of testing at the mean, this technique is not effective at estimating probabilities at either extreme of the stimulus/response curve and should not be used for that purpose if other methods are useable.
- c. It is assumed that the probability of a response versus stimulus level is described by a cumulative, normal distribution.
- d. Step size is fixed and chosen in advance.
- e. Test method is more complex than that of Probit test and less complex than that of Langlie, OSTR, and Neyer D-Optimal tests.
- f. The estimate of the mean is unbiased for practical purposes.
- g. The estimate of the standard deviation is biased to the low side.
- h. A stopping rule is required.
- i. Computations are much simpler than for the other analysis and can be done by hand; however, a computer program is recommended.
- j. The number of trials required is usually fewer than that of Probit test and more than that of Langlie, OSTR, and Neyer D-Optimal tests.
- k. If obtaining the information from the previous trial requires too much effort and cost in order to determine the next stimulus level, this method may not be appropriate.
- l. Once the next stimulus is determined, if the method requires too much time and difficulty to prepare the test item/apparatus for that trial, the method may not be appropriate.

G3.4.2 Bruceton procedure.

- a. Choose the step size for the stimulus. Ideally, it should be equal to the standard deviation (often unknown) of the underlying, normal distribution; if within about 0.5 to 2.0 times the true value, it should be adequate. If the step size is chosen too large, analysis may not be possible; if too small, the analysis may look acceptable but yield a seriously inaccurate estimate of the response versus stimulus curve.
- b. Choose a stopping rule. At least 10 reversals with a zone of mixed results or the maximum number of trials (at least 45 is recommended) shall be used unless otherwise approved in the test plan.
- c. Select a starting point. The starting point should be close to the estimate of the mean value.
- d. Select subsequent stimulus levels one step size above or below the preceding level, depending on whether the last trial resulted in a nonfunction or a function, respectively. Decrease the stimulus level after a function, and increase the stimulus level after a nonfunction.

MIL-STD-331C
w/CHANGE 1
APPENDIX G

Example: A fuze arming test is to be conducted, and 25 fuzes are available. The sample size of 25 is for illustrative purposes only. Normally, a sample size of 45 would be required. It was estimated that approximately half of the fuzes would function at a distance of 120 meters. It is assumed that if a fuze functioned, it was armed. The step size was chosen as 20 meters.

Trial No.	Distance, Meters	Results*
1	120	NF
2	140	F
3	120	NF
4	140	F
5	120	F
6	100	F
7	80	F
8	60	NF
9	80	NF
10	100	NF
11	120	F
12	100	NF
13	120	F
14	100	NF
15	120	NF
16	140	F
17	120	F
18	100	F
19	80	NF
20	100	F
21	80	NF
22	100	F
23	80	NF
24	100	NF
25	120	F

* F = Function; NF = Nonfunction

G3.4.3 Bruceton analysis. The stimuli (distances) and results (function or nonfunction) are used to calculate the maximum likelihood estimates of the mean and standard deviation of a normal distribution. It is assumed that the probability of a response versus stimulus is described by a cumulative, normal distribution. For the example presented, the resulting estimates and probability of arming graph are given by Figure G9-4.

G3.5 Neyer D-Optimal Method. Refer to G5.12 and G5.13 for further information.

G3.5.1 Neyer D-Optimal features.

- a. Designed to estimate both population parameters.
- b. Because of concentration of testing at the D-Optimal points, this technique is the most effective at estimating probabilities at the extreme of the stimulus/response curve.
- c. It is assumed that the probability of a response versus stimulus level is described by a cumulative, normal distribution.

MIL-STD-331C
w/CHANGE 1
APPENDIX G

- d. The stimulus levels vary depending of the initial test parameters as well as all previous test information.
- e. Deviations about any given stimulus level can vary without effecting the validity of the test.
- f. Test method is more complex than all other methods. A computer program is required to calculate the stimulus levels and to perform the analysis.
- g. The estimate of the mean is unbiased for practical purposes.
- h. The estimate of the standard deviation is biased to the low side, but a bias correction (small compared with the variation of the estimate) can be applied.
- i. A stopping rule is required.
- j. The number of trials required is fewer than for any of the other methods.
- k. Because the initial test parameters are only used for the first few tests, the dependence on the initial test parameters is less than for any of the other methods.
- l. If obtaining the information from the previous trial requires too much effort and cost in order to determine the next stimulus level, this method may not be appropriate. A generalization of the test method can be used to test several units at the same time.
- m. Once the next stimulus is determined, if the method requires too much time and difficulty to prepare the test item/apparatus for that trial, the method may not be appropriate. A generalization of the test method can be used to test several units at the same time.
- n. The same software can be used to conduct a C-Optimal test that will concentrate the stimulus levels near any desired extreme probability level if concentrated knowledge of one extreme level is desired.

G3.5.2 Neyer D-Optimal procedure.

- a. Provide a guess for upper and lower estimates of the mean, call these MuMin and MuMax. It is not required that all devices function at MuMax or that no devices function as MuMin. Rather these levels should be chosen based on engineering judgment of the mean. The method will test outside of the MuMin to MuMax range if the true mean lies outside of the range. Also provide a guess for the standard deviation, called SigmaGuess. If an inaccurate guess is chosen, the method will adapt to find a better guess. Start the computer program and enter these values as directed.
- b. Conduct each trial at the stimulus level given by the program. Enter the test results (either a response or a nonresponse) as directed. If the test was conducted at a different test level than specified, then enter the actual stimulus level. The program will calculate the next stimulus level.
- c. The Neyer D-Optimal method uses a multi-phase approach when picking the test levels.
 - c.1 The initial phase consists of finding the region of interest (i.e. a region where some devices respond and some do not.) The first level will be mid way between the upper and lower estimated MuMin and MuMax. The initial step size is the maximum of SigmaGuess and $\frac{1}{4}(\text{MuMax} - \text{MuMin})$. If the first device responds (does not respond), then conduct the next test at a level one step size below (above) the previous level. Double the step size after each test. The first phase ends when there is at least one device responding and one that does not respond. The first phase will usually end after two devices have been tested if the test parameters are optimized to the population.
 - c.2 The second phase consists of a binary search to "home in" on the 50% point. Test each device mid way between the highest level at which a device fails to respond and the lowest level at which a device responds. End this phase when the difference between these two levels is less than or equal to SigmaGuess.
 - c.3 The final phase consists of determining the 2 D-Optimal points (roughly the 15% and 85%

MIL-STD-331C
w/CHANGE 1
APPENDIX G

points of the distribution) assuming a normal distribution using the Maximum Likelihood Estimates for the mean and standard deviation. When there is no zone of mixed results (all the levels at which devices respond are above the levels at which devices do not respond) use the SigmaGuess estimate for the standard deviation, and the average of the lowest level at which a device responded and the highest level at which a device did not respond. Decrement the SigmaGuess by multiplying by 0.8 each time.

- d. The test may be stopped when the sample of devices are tested, or when the analysis shows that the required precision has been achieved.

Example: A drop weight test is to be conducted on an explosive, and 20 samples are available. It was estimated that approximately half of the samples would function at a drop height of 1 meter, and the standard deviation was expected to be 0.1 meter. Set SigmaGuess to 0.1 m, MuMIN to 0.6 meters, and MuMAX to 1.4 meters. For illustrative purposes, assume that the explosive was improperly mixed, raising the true mean threshold to 5 meters, and the standard deviation to 1 m.

Test No.	Drop Height (m)	Results*	Remarks
1	1.00	NF	Start with binary search. Begin phase C1
2	1.20	NF	
3	1.40	NF	Regular explosive would have exploded!
4	1.80	NF	Rapidly increase upper limit to get success quickly.
5	2.60	NF	
6	4.20	F	Both successes and failures! Begin binary search (Phase C2).
7	3.40	NF	
8	3.80	NF	
9	4.00	NF	
10	4.10	NF	
11	4.28	NF	Begin phase C3 (No Overlap. Use $\mu_e = 4.15$, $\sigma_e = \sigma_{guess} = 0.10$.)
12	4.52	NF	$\mu_e = 4.28$, $\sigma_e = 0.19$. (Overlap. Clip MLE values.)
13	5.55	F	$\mu_e = 4.52$, $\sigma_e = 0.79$.
14	5.24	NF	$\mu_e = 4.66$, $\sigma_e = 0.50$. (Use true MLE values.)
15	6.37	F	$\mu_e = 5.22$, $\sigma_e = 0.96$.
16	6.08	NF	$\mu_e = 5.10$, $\sigma_e = 0.83$
17	7.38	F	$\mu_e = 5.70$, $\sigma_e = 1.39$
18	7.09	F	$\mu_e = 5.58$, $\sigma_e = 1.25$

MIL-STD-331C
w/CHANGE 1
APPENDIX G

19	6.89	F	$\mu_e = 5.50, \sigma_e = 1.16$
20	6.74	F	$\mu_e = 5.44, \sigma_e = 1.09.$

* F = Function; NF = Nonfunction

e. For further details on how the strategy proceeds, see Figure G9-5.

G3.5.3 Neyer D-Optimal analysis. The stimuli and results are used to calculate the maximum likelihood estimates of the mean and standard deviation of a normal distribution. It is assumed that the probability of a response versus stimulus is described by a cumulative, normal distribution. Various probability estimates are computed using these population parameters. For the example presented, the resulting estimates and probability of reaction graph are given by Figure G9-5. For an example of a test and the analysis see G5.12.

G3.5.4 Conducting the test.

G3.5.5 Setting the stimulus level. Set the stimulus level (distance to the target, firing voltage, barrier thickness, etc.) selected by the test method. It is important to set the stimulus as close as possible to the value specified by the method for all methods but the Neyer D-Optimal method.

G3.5.6 Test and observe. Test the device and observe whether or not the device responds (arms, functions, etc.).

G4 RELATED INFORMATION

G4.1 References. Greatest economy in expenditure of devices and in analysis of results will be achieved by following the procedures of sensitivity analysis, descriptions of which are to be found in appropriate handbooks and papers.

G4.2 Suggestions for efficient use of samples.

G4.3 Stimulus and response. The five test methods presented in G3 are “sensitivity tests,” a term used in statistical literature to denote an experiment from which quantal response data are observed as the intensity of a stimulus is varied. There are variations of the Probit, which do not require stimulus levels fixed and selected in advance. The stimulus may be the distance from a weapon muzzle to a target and the concomitant response or nonresponse may be the functioning or nonfunctioning of a fuze. The stimulus also may be the striking velocity of a projectile and the response or nonresponse, a penetration or nonpenetration. The stimulus also may be the voltage on a capacitive discharge unit and the response or nonresponse a function or no function, and so on. All applications of these type tests are characterized by the quantal result of a go/no-go, yes/no, success/failure, and so forth. The probability of a response must monotonically increase with increasing stimulus level.

G4.4 Zone of mixed results. Another important characteristic of all sensitivity tests is called a zone of mixed results. If this zone does not occur, the population parameter estimates will not be unique. A zone of mixed results occurs if the largest non-response stimulus level exceeds at least the minimum stimulus level for a response. The chance of not getting a zone of mixed results increases with diminishing sample size.

G4.5 Stopping rule. When conducting one of the test strategies of Section G3, or any sensitivity test, there must be a stopping rule. The most common is to fix the maximum number of trials in advance. Another strategy gaining favor is selecting in advance the number of reversals of response. Detailed stopping rules are discussed under each test strategy described in Section G3.

G4.5 Changing stimulus level. Common test strategies, including those employed here,

are of three types with regard to how the stimulus level is changed: (1) stimulus levels are fixed and selected in advance, for example the Probit method; (2) stimulus levels are of fixed step size, for example the Bruceton method; and (3) stimulus levels are of variable step size, for example the Langlie, OSTR, and Neyer D-Optimal test methods.

G5 BIBLIOGRAPHY

- G5.1** NAVORD Report 2879, *A General Test Plan for the Collection of Data Which Are to Be Analyzed by the Probit Method*, by P. B. Morgan.
- G5.2** Ordnance Corps Pamphlet, ORDP 20-111, *Ordnance Engineering Design Handbook, Experimental Statistics*, Section 2--Analysis of Enumerative and Classificatory Data, June 1962.
- G5.3** Langlie, H. J., *A Reliability Test Method for One-Shot Items*, Aeronutronic Division, Ford Motor Company, Publication No. U-1792, August 1962.
- G5.4** Einbinder, S. K., *One-Shot Sensitivity Test for Extreme Percentage Points*, Proceedings of the Nineteenth Conference on the Design of Experiments in Army Research, Development and Testing, ARO-D Report 74-1, pp. 369-386, 1974.
- G5.5** Einbinder, S. K., *A Sequential Sensitivity Test for Extreme Percentage Point and Estimation Using a Weibull Response Model*, 17th U.S. Army Operations Research Symposium, Fort Lee, VA, 6-9 Nov 1978.
- G5.6** DARCOM P706-103, *Engineering Design Handbook, Selected Topics in Experimental Statistics with Army Applications*, Chapter 9, 1983.
- G5.7** Finney, D. J., *Probit Analysis*, 2nd Edition, Cambridge University Press, Cambridge, England, 1952.
- G5.8** National Bureau of Standards, *Experimental Statistics*, Handbook 91, 1966.
- G5.9** Dixon, W. J., and Massey, F. J., Jr., *Introduction to Statistical Analysis*, Chapter 19, McGraw-Hill Book Co., Inc.
- G5.10** Dixon, W. J., and Mood, A. M., "A Method for Obtaining and Analyzing Sensitivity Data," *Journal of American Statistical Association*, Vol. 43, 1948.
- G5.11** Statistical Research Group, Princeton University, *Statistical Analysis for a New Procedure in Sensitivity Experiments*, AMP Report 101.1R, SRG-P No. 4 (OSDR Report 4040), July 1944.
- G5.12** Neyer, B. T., "A D-Optimality Based Sensitivity Test," *Technometrics*, Vol 36, 1994.
- G5.13** Neyer, B. T., *Analysis of Sensitivity Tests*, EG&G Mound Applied Technologies, Miamisburg, Ohio, Publication No. MLM-3736, March 1992.

G6 GLOSSARY

- all-arm distance** - minimum distance from the gun muzzle at which all fuzes will arm, at a specified probability level.
- all-fire level** - the minimum level that will result in the device functioning, at a specified probability level.
- biased estimate** - a statistic whose average in the long run differs from the true value of the parameter it is intended to estimate.
- cumulative distribution function** - a mathematical expression which provides the probability that a random variable is less than or equal to any given value.
- extreme percentile** - a value of a random variable (whose range is 0 to 1) for which the cumulative distribution function is either close to 0 or close to 1, that is, a value in the lower or upper tail of the distribution.
- monotonicity** - the characteristic of a quantity or function to remain at its current direction of

MIL-STD-331C
w/CHANGE 1
APPENDIX G

growth. A monotonic increasing function or event is one that never decreases as the abscissa increases; likewise, a monotonic decreasing function is one that never increases as the abscissa increases.

no-arm distance - maximum distance from the gun muzzle at which no fuze will arm at a specified probability level.

quantal response - an observation that can only fall into one or the other of two qualitative categories, for example, response/nonresponse, go/no-go, success/failure, open/closed, and so forth.

quantile - values obtained by equal subdivisions of the data, for example, quartiles, deciles, and percentiles.

response - an observed reaction of a test unit to the imparted stimulus level, for example, fracture, detonation, deformation, penetration, arming, and so forth. The absence of an observed reaction is referred to as a nonresponse.

reversal - a change in results from function to nonfunction or vice versa.

stimulus level - that value of the test variable imparted to an individual test unit, for example, voltage, pressure, temperature, time, drop height, dose, distance, and so forth.

strategy - a well-defined plan or structured approach to choice of stimulus levels for a sensitivity test. The sequence of levels may or may not depend on the set of prior responses.

unbiased estimate - a statistic whose average in the long run is the true value of the parameter it is intended to estimate.

zone of mixed results - a function occurring at a lower stimulus level than some nonfunction.

TABLE G9-I. Lower Tail Percentiles Estimated by OSTR Strategies

n	If Following Occurs, Increase Stimuli Level (*)	If Following Occurs, Decrease Stimuli Level	Percentage Point Estimated
2	00	0X, X	.2929
3	000	00X, 0X, X	.2063
3a	000, 00X0	00XX, 0X, X	.2664
4	0000	000X, 00X, 0X, X	.1591
4a	0000, 000X0	000XX, 00X, 0X, X	.1959
5	00000	0000X, 000X, 00X, 0X, X	.1294
5a	00000, 0000X0	0000XX, 000X, 00X, 0X, X	.1540
6	000000	00000X, etc.	.1091
7	0000000	000000X, etc.	.0943
8	00000000	0000000X, etc.	.0830
9	000000000	00000000X, etc.	.0741
10	0000000000	000000000X, etc.	.0670
14	00000000000000	0000000000000, etc.	.0483

* 0 = Nonfunction and X = Function

MIL-STD-331C
w/CHANGE 1
APPENDIX G

TABLE G9-II. Upper Tail Percentiles Estimated by OSTR Strategies

n	If Following Occurs, Decrease Stimuli Level (*)	If Following Occurs, Increase Stimuli Level	Percentage Point Estimated
2	XX	X0, 0	.7071
3	XXX	XX0, X0, 0	.7937
3a	XXX, XX0X	XXX0, X0, 0	.7336
4	XXXX	XXX0, XX0, X0, 0	.8409
4a	XXXX, XXX0X	XXX00, XX0, X0, 0	.8041
5	XXXXX	XXXX0, XXX0, XX0, X0, 0	.8706
5a	XXXXX, XXXX0X	XXXX00, XXX0, XX0, X0, 0	.8460
6	XXXXXX	XXXXX0, etc.	.8909
7	XXXXXXX	XXXXXXX0, etc.	.9057
8	XXXXXXXX	XXXXXXXX0, etc.	.9170
9	XXXXXXXXXX	XXXXXXXXXX0, etc.	.9259
10	XXXXXXXXXXX	XXXXXXXXXXX0, etc.	.9330
14	XXXXXXXXXXXXXXX	XXXXXXXXXXXXXXX0, etc.	.9517

* X = Function and 0 = Nonfunction

MIL-STD-331C
w/CHANGE 1
APPENDIX G

NUMBER OF ROUNDS = 50
MEAN = 17.57
STANDARD DEV. = 6.48 METERS

X- ESTIMATED ARMING RATE

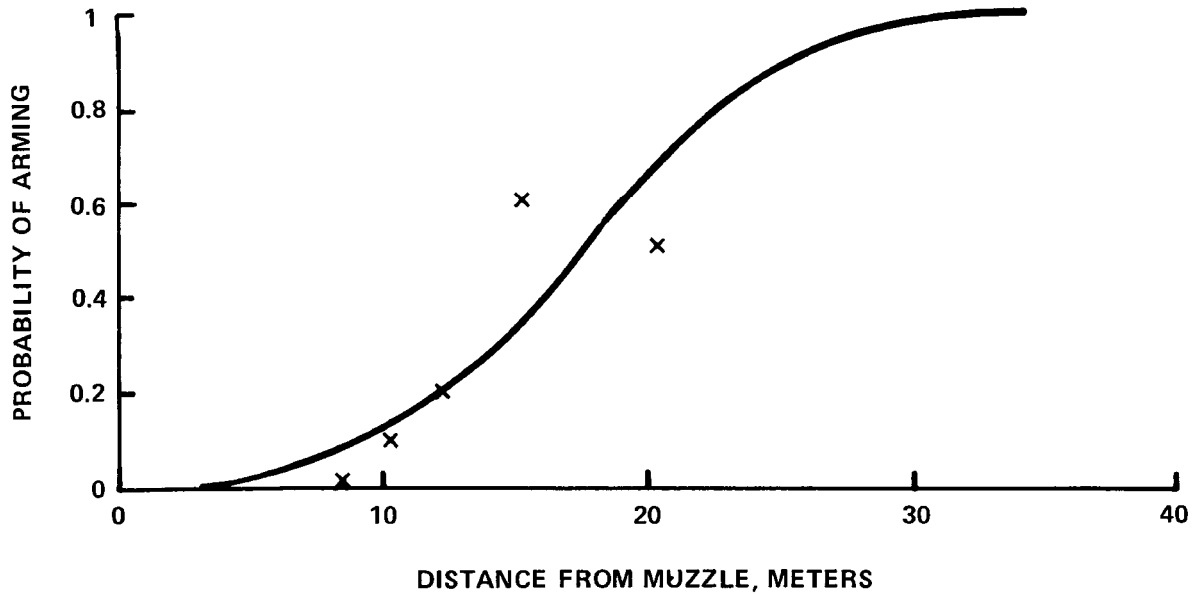

FIGURE G9-1. Estimated Probability of Arming Versus Distance from Muzzle (Probit Method)

NUMBER OF ROUNDS = 20
MEAN = 43.04 METERS
STANDARD DEV. = 7.82 METERS

○ - NON-FUNCTION
+ -FUNCTION

208-2

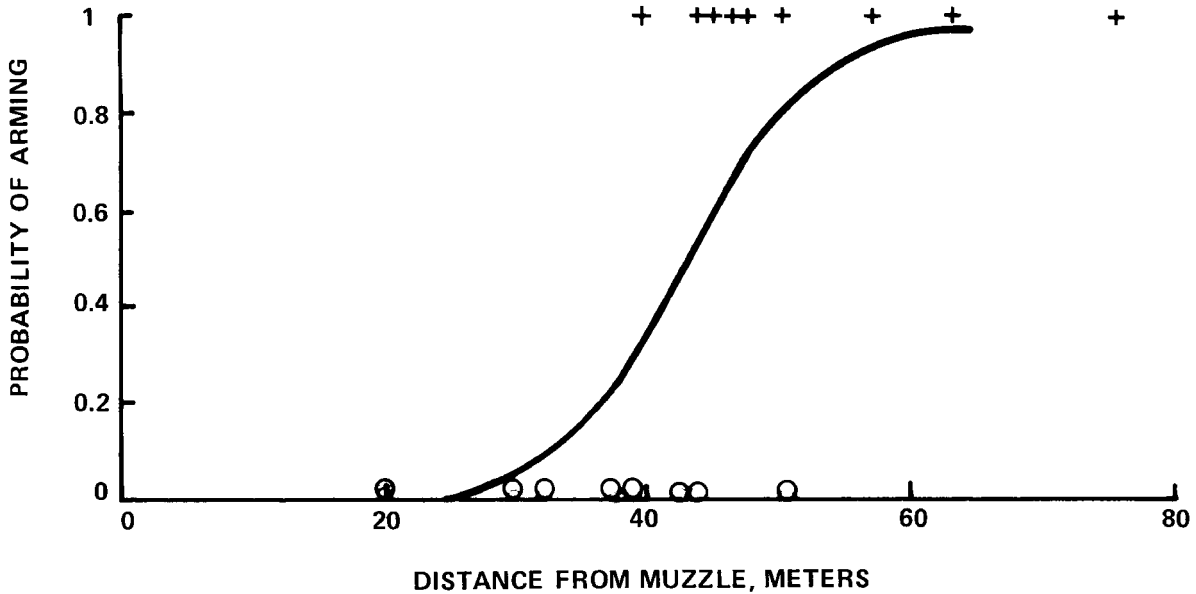

FIGURE G9-2. Estimated Probability of Arming Versus Distance from Muzzle (Langlie Method)

MIL-STD-331C
w/CHANGE 1
APPENDIX G

NUMBER OF ROUNDS = 21
MEAN = 10.29 METERS
STANDARD DEV. = 0.56 METERS

○ - NON-FUNCTION
+ - FUNCTION

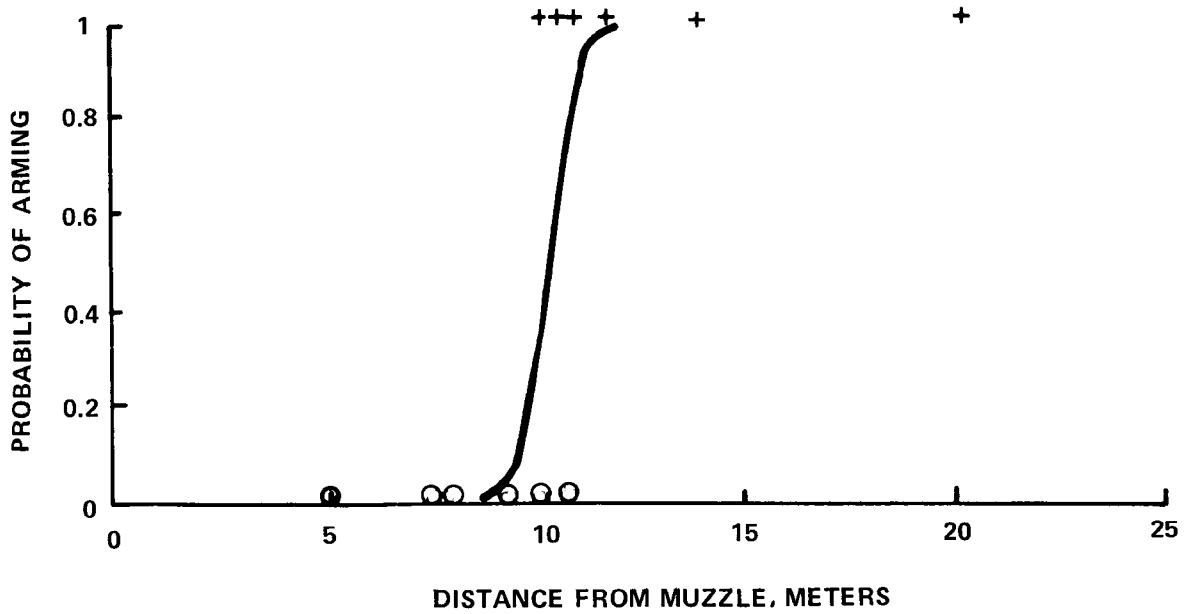

FIGURE G9-3. Estimated Probability of Arming Versus Distance from Muzzle (OSTR Method)

NUMBER OF ROUNDS = 25
MEAN = 104.01 METERS
STANDARD DEV. = 27.43 METERS

○ - NON-FUNCTION
+ - FUNCTION

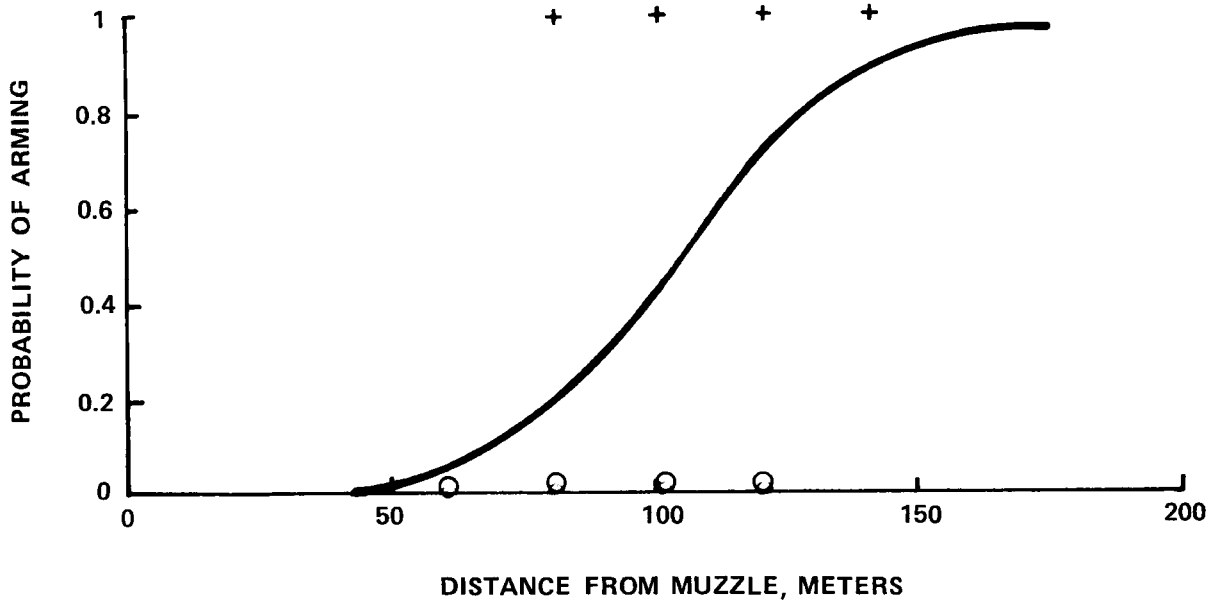

FIGURE G9-4. Estimated Probability of Arming Versus Distance from Muzzle (Bruceton Method)

Sample Size = 20
Mean = 5.39 meters
Standard Dev. = 1.04 meters

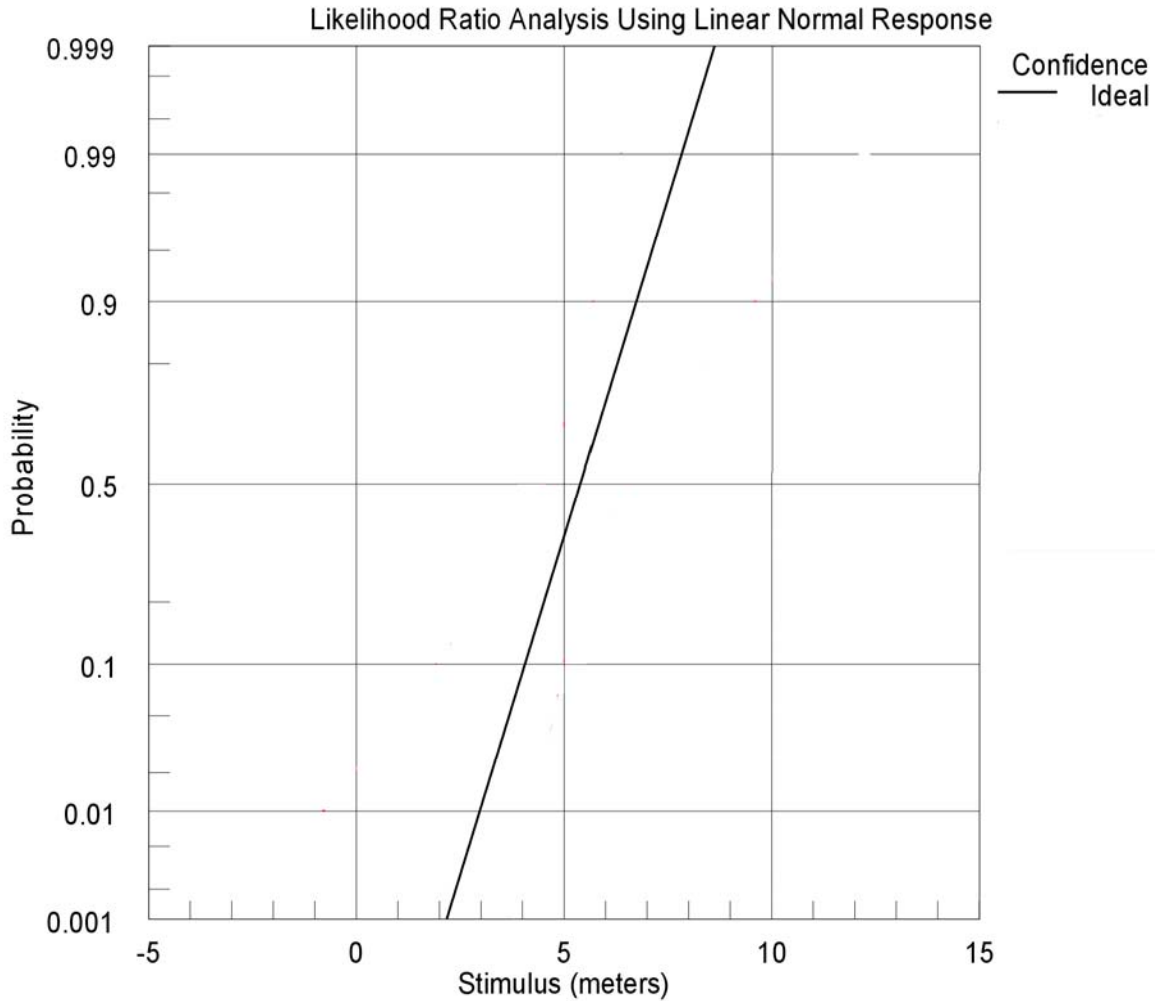

FIGURE G9-5. Estimated Probability of Reaction Versus Weight Drop Height (Neyer D-Optimal Method)

CONCLUDING MATERIAL

Custodians:

Army – AR
Navy – OS
Air Force – 99

Preparing Activity:

Army – AR

Review activities:

Army – EA, MI, MT, TE
Navy - NP
Air Force – 70

(Project #13GP-2009-001)

NOTE: The activities listed above were interested in this document as of the date of this document. Since organizations and responsibilities can change, you should verify the currency of the information above using the ASSIST Online database at <http://assist.daps.dla.mil> .