

MILITARY STANDARD

MIL-STD-1388-1A
 Notice 4
 21 Jan 93

LOGISTIC SUPPORT ANALYSIS

TO ALL HOLDERS OF MIL-STD-1388-1A

1. THE FOLLOWING PAGES OF MIL-STD-1388-1A HAVE BEEN REVISED AND SUPERSEDE THE PAGES LISTED:

NEW PAGE(S)	DATE	SUPERSEDED PAGE(S)	DATE
iii		iii	28 March 1991
iv	11 April 1983		REPRINTED WITHOUT CHANGE
v		v	11 April 1983
vi	11 April 1983		REPRINTED WITHOUT CHANGE
1		1	11 April 1983
2 and 3		2 and 3	28 March 1991
4		4	11 April 1983
4a		NEW	
5		5	9 February 1988
6	9 February 1988		REPRINTED WITHOUT CHANGE
7			9 February 1988
8		8	9 February 1988
15	11 April 1983	15	REPRINTED WITHOUT CHANGE
16		16	28 March 1991
17		17	9 February 1988
17a		NEW	
18	11 April 1983		REPRINTED WITHOUT CHANGE
27	11 April 1983		REPRINTED WITHOUT CHANGE
28		28	28 March 1991
37		37	1 April 1983
38	28 March 1991		REPRINTED WITHOUT CHANGE
39		39	9 February 1988
40	11 April 1983		REPRINTED WITHOUT CHANGE
41	28 March 1991		REPRINTED WITHOUT CHANGE
42		42	28 March 1991
43		43	28 March 1991
44		44	11 April 1983
44a		NEW	
57	11 April 1983		REPRINTED WITHOUT CHANGE
58		58	28 March 1991
59		59	11 April 1983
60		60	28 March 1991
60a and 60b		NEW	
69	11 April 1983		REPRINTED WITHOUT CHANGE

AMSC No A3202

FSC ILSS

DISTRIBUTION STATEMENT A. Approved for public release; distribution is unlimited.

NEW PAGE(S)	DATE	SUPERSEDED PAGE(S)	DATE
70		70	11 April 1983
71		71	11 April 1983
71a thru 71d		NEW	
72	11 April 1983		REPRINTED WITHOUT CHANGE
75		75	11 April 1983
76	11 April 1983		REPRINTED WITHOUT CHANGE
87		87	11 April 1983
88	11 April 1983		REPRINTED WITHOUT CHANGE
89		89	11 April 1983
90	11 April 1983		REPRINTED WITHOUT CHANGE
99 thru 102		99 thru 102	5 June 1990
102a		NEW	
103	11 April 1983		REPRINTED WITHOUT CHANGE
104 thru 108		104 thru 108	11 April 1983
109 thru 112a		109 thru 112a	28 March 1991
112b thru 112e		NEW	

2. RETAIN THIS NOTICE AND INSERT BEFORE TABLE OF CONTENTS

3. Holders of MIL-STD-1388-1A will verify that the page changes indicated herein have been entered. This notice will be retained as a check sheet. This issuance is a separate publication. Each notice is to be retained by stocking points until the military standard is completely revised or cancelled.

Custodians:
 Army - TM
 Navy - AS
 Air Force - 95

Preparing Activity
 Army - TM

(Project No. ILSS-0005)

Reviewing Activities:

Army - ME, MI, AV, AT, CR
 Navy - SH, YD, OS, MC
 Air Force - 11, 13, 15, 16, 17
 Miscellaneous DOD/NASA - NS, NA, DC, DH, DS

FOREWORD

This standard implements the Logistic Support Analysis (LSA) guidelines and requirements established by Department of Defense (DOD) Instruction 5000.2, Major System Acquisition Procedures and supersedes MIL-STD-1561, 17 Nov 84, Uniform DOD Provisioning Procedures. The requirements of this standard are applicable to major and less-than-major system/equipment acquisition programs, major modification programs, and applicable research and development projects. The goal of this standard is a single, uniform approach by the Military Services for conducting those activities necessary to (a) cause supportability requirements to be an integral part of system requirements and design, (b) define support requirements that are optimally related to the design and to each other, (c) define the required support during the operational phase, and (d) prepare attendant data products. LSA is the selective application of scientific and engineering efforts undertaken during the acquisition process, as part of the system engineering and design process, to assist in complying with supportability and other Integrated Logistic Support (ILS) objectives through the use on an iterative process of definition, synthesis, tradeoff, test, and evaluation.

This standard provides general requirements and descriptions of tasks which, when performed in a logical and iterative nature, comprise the LSA process. The tasks are structured for maximum flexibility in their application. In addition to the general requirements and task description sections, this standard contains an application guidance appendix which provides rationale for the selection and tailoring of the tasks to meet program objectives in a cost effective manner. This document is intentionally structured to discourage indiscriminate blanket applications. Tailoring is forced by requiring that specific tasks be selected and that certain essential information relative to implementation of the selected tasks be provided by the requiring authority. Additionally, the user must be aware that when the LSA process, or a portion thereof, is implemented contractually, more than the LSA statement of work and LSA deliverable data requirements must be considered. Readiness and supportability requirements and objectives must be appropriately integrated and embodied in specifications, general and special contract provisions, evaluation factors for award, instructions to offerors, and other sections of the solicitation document.

Defense system acquisitions are directed toward achieving the best balance between cost, schedule, performance, and supportability. Increasing awareness that supportability factors, such as manpower and personnel skills, are a critical element in system effectiveness has necessitated early support analyses, the establishment of system constraints, design goals, thresholds and criteria in these areas, and the pursuit of design, operational, and support approaches which optimize life cycle costs and the resources required to operate and maintain systems. This standard was prepared to identify these early analysis requirements and foster their cost effective application during system acquisitions.

CONTENTS

<u>Paragraph</u>		<u>Page</u>
1.	SCOPE.....	1
1.1	Purpose	1
1.2	Application of Standard	1
1.2.1	Tailoring of Task Descriptions.....	1
1.3	Method of Reference.....	1
1.4	Scope of Performance	1
1.5	Parts.....	1
2.	REFERENCED DOCUMENTS	1
2.1	General	1
3.	DEFINITIONS	2
3.1	General	2
4.	GENERAL REQUIREMENTS.....	2
4.1	LSA Program.....	2
4.1.1	Program Interfaces and Coordination.....	2
4.1.2	LSA Process	2
4.2	Quantitative Requirements	3
4.3	Management, Surveillance, and Control	3
4.4	LSA Documentation.....	3
4.4.1	Logistic Support Analysis Record Format.....	4
5.	TASK DESCRIPTIONS	4
5.1	General	4
5.1.1	Task Structure	4
5.2	Task Section 100 - Program Planning and Control.....	9
5.2.1	Task 101 - Development of an Early Logistic Support Analysis Strategy.....	10
5.2.2	Task 102 - Logistic Support Analysis Plan.....	12
5.2.3	Task 103 - Program and Design Reviews	15
5.3	Task Section 200 - Mission and Support Systems Definition.....	18
5.3.1	Task 201 - Use Study	19
5.3.2	Task 202 - Mission Hardware, Software, and Support System Standardization	21
5.3.3	Task 203 - Comparative Analysis	23
5.3.4	Task 204 - Technological Opportunities.....	26
5.3.5	Task 205 - Supportability and Supportability Related Design Factors.....	28
5.4	Task Section 300 - Preparation and Evaluation of Alternatives	30
5.4.1	Task 301 - Functional Requirements Identification.....	31

CONTENTS - Continued

		<u>Page</u>
Paragraph 5.4.2	Task 302 - Support System Alternatives.....	34
5.4.3	Task 303 - Evaluation of Alternatives and Tradeoff Analysis.....	36
5.5	Task 400 - Determination of Logistic Support Resource Requirements	40
5.5.1	Task 401 - Task Analysis	41
5.5.2	Task 402 - Early Fielding Analysis.....	45
5.5.3	Task 403 - Post Production Support Analysis.....	47
5.6	Task Section 500 - Supportability Assessment.....	48
5.6.1	Task 501 - Supportability Test, Evaluation, and Verification	49

FIGURES

Figure 1	Logistic Support Analysis Process Objectives by Program Phase.....	52
2	Logistic Support Analysis Process Overview	53
3	Logistic Support Analysis Process Flowchart.....	54
3a	Supportability Standards Information Relationships	60b
4	System Level Logistic Support Analysis Interfaces.....	61
5	Logistic Support Analysis Tailoring Decision Logic.....	64
6	Provisioning Performance Schedule	71d

TABLES

Table I	Index of Logistic Support Analysis Tasks	5
II	Logistic Support Analysis Information Requirements for Major Systems by Milestone	95
III	Logistic Support Analysis Task Application and Documentation Matrix	98

APPENDIX A - APPLICATION GUIDANCE FOR IMPLEMENTATION OF
LOGISTIC SUPPORT ANALYSIS PROGRAM REQUIREMENTS

<u>Paragraph</u>		<u>Page</u>
10.	SCOPE.....	58
10.1	General.....	58
10.2	How to Use This Appendix.....	58
20.	REFERENCED DOCUMENTS	58
30.	DEFINITIONS	59
40.	GENERAL APPLICATION GUIDANCE FOR LOGISTIC SUPPORT ANALYSIS	
	PROGRAMS.....	59
40.1	LSA Process	59
40.1.1	Analysis of Supportability.....	59
40.1.2	Assessment and Verification.....	59
40.1.3	Interfaces	60
40.1.3.1	Inputs and Outputs for System Level LSA.....	60
40.1.3.2	Refinement and Extension of the System Level LSA	60
40.1.3.3	Task Analysis Interfaces	60
40.1.3.4	Resource Requirements Identification	62
40.2	Major Criteria.....	62
40.2.1	Manpower and Personnel Constraints.....	62
40.2.2	System Readiness	62
40.2.3	Cost.....	62
40.3	Strategy in Developing Analysis Requirements.....	63
40.3.1	General	63
40.3.2	Task Selection and Focusing.....	63
40.3.2.1	General	63
40.3.2.2	Focusing	65
40.3.3	Factors Impacting on Strategy.....	66
40.3.3.1	Type of Program/Change	66
40.3.3.2	Amount of Design Freedom	66
40.3.3.3	Time and Resources Available.....	67
40.3.3.4	Work Already Done	67
40.3.3.5	Past Experience and Historical Data	68
40.3.3.6	Procurement Considerations.....	68
40.4	Application in Procurement.....	68
40.4.1	Pre-RFP and Bidders Briefings	68
40.4.2	Preparing LSA RFP Requirements.....	69
40.4.2.1	Broad Versus Specifics	69
40.4.2.2	Interweave Supportability Requirements and Constraints	69
40.4.2.3	Relative Importance of Requirements	70
40.4.2.4	Support Related Design Drivers.....	70
40.4.2.5	Alternate Support Concepts	70
40.4.2.6	Evaluation Methods and Models.....	70

1. SCOPE

1.1 Purpose. This standard provides general requirements and task descriptions governing performance of Logistic Support Analysis (LSA) during the life cycle of systems and equipment.

1.2 Application of Standard. This standard applies to all system/equipment acquisition programs, major modification programs, and applicable research and development projects through all phases of the system/equipment life cycle. This standard is for use by both contractor and Government activities performing LSA on systems/equipment to which this standard applies. As used in this standard, the "requiring authority" is generally a Government activity but may be a contractor when LSA requirements are levied on subcontractors. The "performing activity" may be either a contractor or Government activity. The use of the term "contract" in this standard includes any document of agreement between organizations to include between a Government activity and another Government activity, between a Government activity and a contractor, or between a contractor and another contractor.

1.2.1 Tailoring of Task Descriptions. Individual tasks contained in this standard shall be selected and the selected task descriptions tailored to specific acquisition program characteristics and life cycle phase. Application guidance and rationale for selecting tasks and tailoring task descriptions to fit the needs of a particular program are included in Appendix A. This appendix is not contractual and does not establish requirements.

1.2.2 Provisioning Requirements. This standard prescribes terms and conditions of provisioning data requirements for the provisioning process, and the responsibility of the performing activity in the provisioning of items which it manufactures and all appropriate sub-contracted items incorporated within end items of its manufacture.

1.3 Method of Reference. This standard, the specific task description number(s), applicable task input to be specified by the requiring authority and applicable task outputs shall be included or referenced in the Statement of Work (SOW).

1.4 Scope of Performance. The performing activity shall comply with the general requirements section and specific task requirements only to the degree specified in the contract.

1.5 Parts. MIL-STD-1388-1 is Part I of two parts.

2. REFERENCED DOCUMENTS

2.1 General. Unless otherwise specified, the following standards and handbooks of the issue listed in that issue of the Department of Defense Index of Specifications and Standards (DoDISS) specified in the solicitation form a part of this standard to the extent specified herein.

MIL-STD-1388-1A

Military Standards.

MIL-STD-480	Configuration Control - Engineering Changes, Deviations and Waivers
MIL-STD-1366	Materiel Transportation System Dimensional and Weight Constraints, Definition of.
MIL-STD-1388-2	DOD Requirements for a Logistic Support Analysis Record.
MIL-STD-1390	Level of Repair Analysis
MIL-STD-1478	Task Performance Analysis
MIL-STD-1629	Procedures for Performing a Failure Mode, Effects, and Criticality Analysis.
MIL-H-46855	Human Engineering Requirements for Military Systems, Equipment, and Facilities
MIL-T-31000	Specifications for Technical Data Packages

Other Documents

DODD 5000.1	Defense Acquisition
DODI 5000.2	Defense Acquisition Management Policies and Procedures
DOD 4100.38M	Provisioning and Other Preprocurement Screening Manual

(Copies of specifications, standards, drawings, and publications required by contractors in conjunction with specific procurement functions should be obtained from the procuring activity or as directed by the contracting officer.)

3. DEFINITIONS

3.1 General. Key terms used in this standard are defined in the Glossary, Appendix B.

4. GENERAL REQUIREMENTS

4.1 LSA Program. An effective LSA program shall be established and maintained as part of the ILS program. It shall be planned, integrated, developed, and conducted in conjunction with other requirement definition, design, development, production, and deployment functions to cost effectively

achieve overall program objectives. The LSA program shall be established consistent with the type and phase of the acquisition program, and procedures shall be established to assure that the LSA program is an integral part of the system engineering process. Interfaces between the LSA program and other system engineering programs shall be identified. The LSA program shall include the management and technical resources, plans, procedures, schedules, and controls for the performance of LSA requirements.

4.1.1 Program Interfaces and Coordination. Maximum use shall be made of analyses and data resulting from requirements of other system engineering programs to satisfy LSA input requirements. Tasks and data required by this standard, which are also required by other standards and specifications, shall be coordinated and combined to the maximum extent possible. LSA data shall be based upon, and traceable to, other system engineering data and activities where applicable. Design and performance information shall be captured, disseminated, and formally controlled from the beginning of the design effort to serve as the design audit trail for logistic support resource planning, design tradeoff study inputs, and LSA documentation preparation.

4.1.2 LSA Process. A systematic and comprehensive analysis shall be conducted on an iterative basis through all phases of the system/equipment life cycle to satisfy supportability (supportability includes all elements of ILS as defined in DoDI 5000.2 required to operate and maintain the system/equipment) objectives. The level of detail of the analyses and the timing of task performance shall be tailored to each system/equipment and shall be responsive to program schedules and milestones. Figure 1 depicts the major LSA process objectives by program phase. Figures 2 and 3 provide an overview of the LSA process and a detailed flow chart of the LSA process. Task and subtask applicability guidance by program phase is provided in Appendix A, Table III.

4.2 Quantitative Requirements. Quantitative supportability and supportability related design requirements for the system/equipment shall be included in appropriate sections of the system or end item specifications, other requirements documents, or contracts, as appropriate subtier values not established by the requiring authority shall be established by the performing activity. Requirements shall be defined in terms related to operational readiness, demand for logistic support resources, and operating and support (O&S) costs, as applicable to the type of system/equipment.

4.3 Management, Surveillance, and Control. Management procedures shall be established to assure continuing assessment of analysis results and to allow for system/equipment design and LSA program adjustments as required. Feedback and corrective action procedures shall be established which include controls to assure that deficiencies are corrected and documented. Assessments, validations, and verifications shall be conducted throughout the system/equipment life cycle to demonstrate, within stated confidence levels, the validity of the analyses performed and the products developed from the analyses, and to adjust the analysis results and products as applicable.

4.4 LSA Documentation. LSA documentation shall consist of all data resulting from analysis tasks conducted under this standard and shall be the primary source of validated, integrated design related supportability data pertaining to an acquisition program. LSA documentation shall be developed and maintained commensurate with design, support, and operational concept development, and shall be updated to reflect changes or availability of better information based on testing, configuration changes, operational concept changes, and support concept changes during the acquisition process. Accumulated LSA documentation shall provide an audit trail of supportability and supportability related design analyses and decisions, and shall be the basis for actions and documents related to manpower and personnel requirements, training programs, provisioning, maintenance planning, resources allocation, funding decisions, and other logistic support resource requirements. Configuration control procedures shall be established over LSA documentation updates to assure proper coordination among other system engineering programs, the LSA program, and the development of ILS documents using LSA data. Deliverable documentation shall be as specified in applicable data item descriptions cited on contract data requirements list (CDRL), DD Form 1423. When the requiring authority desires delivery of the task outputs, as described in paragraph 5 of this standard, for LSA tasks or subtasks cited in the SOW, then appropriate data item descriptions and delivery information must be included in the CDRL.

4.4.1 Logistic Support Analysis Record Format. The logistic support analysis record (LSAR) is a subset of LSA documentation and LSAR data elements shall conform to the requirements of MIL-STD-1388-2. Deliverable LSAR data shall be as specified in data item descriptions cited on the CDRL.

5. TASK DESCRIPTIONS

5.1 General. The LSA tasks are divided into five general sections: Section 100, Program Planning and Control; Section 200, Mission and Support Systems Definition; Section 300, Preparation and Evaluation of Alternatives; Section 400, Determination of Logistic Support Resource Requirements; and Section 500, Supportability Assessment. Table I identifies the general purpose of each section, the individual tasks contained in each section, and the general purpose of each task and subtask.

5.1.1 Task Structure. Each individual task is divided into four parts: purpose, task description, task input, and task output. The purpose provides the general reason for performing the task. The task description provides the detailed subtasks which comprise the overall task. It is not intended that all tasks and/or subtasks be accomplished in the sequence presented. The sequence of task and subtask accomplishments should be tailored to the individual acquisition program. Where applicable, the subtasks are organized to correspond with relative timing of performance during the acquisition process. Consequently, for some tasks, all subtasks may not be required to be performed for a given contract period. In these cases, the SOW shall specify the applicable subtask requirements.

(See Appendix A for guidance.) The task input identifies the general information required to define the scope of and perform each task. That input information which shall be specified by the requiring authority in the SOW is annotated by an asterisk (*). The task output identifies the expected results from performance of the task. When an element of the task input or task output is only applicable to certain subtasks, the applicable subtask numbers are identified in parentheses following the element. Where subtask numbers are not listed, that element is applicable to all subtasks listed under the task description.

TABLE I. Index of Logistic Support Analysis Tasks.

TASK SECTION	PURPOSE OF TASK SECTION	TASK/SUBTASK	INFLUENCE *		
			SYS/EQUIP DESIGN	SUPPT SYS DESIGN	LOG REGRTS OR TEN-MINATION
100 - PROGRAM PLANNING & CONTROL	TO PROVIDE FOR FORMAL PROGRAM PLANNING AND REVIEW ACTIONS	101 - DEVELOPMENT OF AN EARLY LOGISTIC SUPPORT ANALYSIS STRATEGY			
		101.2.2 COST ESTIMATE			
		101.2.3 UPDATES			
		102 - LOGISTIC SUPPORT ANALYSIS PLAN			
		102.2.1 LSA PLAN			
		102.2.2 UPDATES			
		103 - PROGRAM AND DESIGN REVIEWS			
		103.2.1 ESTABLISH REVIEW PROCEDURES			
		103.2.2 DESIGN REVIEWS			
		103.2.3 PROGRAM REVIEWS			
200 - MISSION & SUPPORT SYSTEMS DEFINITION	TO ESTABLISH SUPPORTABILITY OBJECTIVES AND SUPPORTABILITY RELATED DESIGN GOALS, THRESHOLDS, AND CONSTRAINTS THROUGH COMPARISON WITH EXISTING SYSTEMS AND ANALYSES OF SUPPORTABILITY, COST, AND READINESS DRIVERS	201 - USE STUDY			
		201.2.1 SUPPORTABILITY FACTORS	X	X	
		201.2.2 QUANTITATIVE FACTORS	X	X	
		201.2.3 FIELD VISITS	X	X	
		201.2.4 USE STUDY REPORT AND UPDATES	X	X	
		202 - MISSION HARDWARE, SOFTWARE, AND SUPPORT SYSTEM STANDARDIZATION			
		202.2.1 SUPPORTABILITY CONSTRAINTS	X	X	X
		202.2.2 SUPPORTABILITY CHARACTERISTICS	X	X	
		202.2.3 RECOMMENDED APPROACHES	X	X	
		202.2.4 RISKS	X	X	X

PRIMARY PURPOSE OF 100 SERIES TASKS IS THE MANAGEMENT AND CONTROL OF THE LSA PROGRAM

* X INDICATES THAT THE SUBTASK IS ORIENTED TOWARD INFLUENCING THE INDICATED FACTOR(S)

DLA-STD-1388-1A

TABLE I. Index of Logistic Support Analysis Tasks. - Continued

TASK SECTION	PURPOSE OF TASK SECTION	TASK/SUBTASK	INFLUENCE *		
			SYS/EQUIP DESIGN	SUPPT SYS DESIGN	LOG REGRTE DETERMINATION
		203 - COMPARATIVE ANALYSIS			
		203.2.1 IDENTIFY COMPARATIVE SYSTEMS	X	X	
		203.2.2 BASELINE COMPARISON SYSTEM	X	X	
		203.2.3 COMPARATIVE SYSTEM CHARACTERISTICS	X	X	
		203.2.4 QUALITATIVE SUPPORTABILITY PROBLEMS	X	X	
		203.2.5 SUPPORTABILITY, COST, AND READINESS DRIVERS	X	X	
		203.2.6 UNIQUE SYSTEM DRIVERS	X	X	
		203.2.7 UPDATES	X	X	
		203.2.8 RISKS AND ASSUMPTIONS	X	X	
		204 - TECHNOLOGICAL OPPORTUNITIES			
		204.2.1 RECOMMENDED DESIGN OBJECTIVES	X	X	
		204.2.2 UPDATES	X	X	
		204.2.3 RISKS	X	X	
		205 - SUPPORTABILITY AND SUPPORTABILITY RELATED DESIGN FACTORS			
		205.2.1 SUPPORTABILITY CHARACTERISTICS		X	
		205.2.2 SENSITIVITY ANALYSIS	X	X	
		205.2.3 IDENTIFY PROPRIETARY DATA	X	X	
		205.2.4 SUPPORTABILITY OBJECTIVES & ASSOCIATED RISKS	X	X	
		205.2.5 SPECIFICATION REQUIREMENTS	X	X	
		205.2.6 NATO CONSTRAINTS	X	X	
		205.2.7 SUPPORTABILITY GOALS AND THRESHOLDS	X	X	

MIL-STD-1388-1A

TABLE I. Index of Logistic Support Analysis Tasks. - Continued

TASK SECTION	PURPOSE OF TASK SECTION	TASK/SUBTASK	INFLUENCE *			
			SYS/EQMP DESIGN	SUPPT SYS DESIGN	LOG REQMTS DETERMINATION	
300 - PREPARATION AND EVALUATION OF ALTERNATIVES	TO OPTIMIZE THE SUPPORT SYSTEM FOR THE NEW ITEM AND TO DEVELOP A SYSTEM WHICH ACHIEVES THE BEST BALANCE BETWEEN COST, SCHEDULE, PERFORMANCE, AND SUPPORTABILITY	301 - FUNCTIONAL REQUIREMENTS				
		301.2.1 FUNCTIONAL REQUIREMENTS		X		
		301.2.2 UNIQUE FUNCTIONAL REQUIREMENTS		X		
		301.2.3 RISKS		X		
		301.2.4 OPERATIONS AND MAINTENANCE TASKS		X	X	
		301.2.5 DESIGN ALTERNATIVES	X			
		301.2.6 UPDATES		X	X	
		302 - SUPPORT SYSTEM ALTERNATIVES				
		302.2.1 ALTERNATIVE SUPPORT CONCEPTS		X		
		302.2.2 SUPPORT CONCEPT UPDATES		X		
		302.2.3 ALTERNATIVE SUPPORT PLANS		X		
		302.2.4 SUPPORT PLAN UPDATES		X		
		302.2.5 RISKS		X		
		303 - EVALUATION OF ALTERNATIVES AND TRADEOFF ANALYSIS				
		303.2.1 TRADEOFF CRITERIA		X	X	X
		303.2.2 SUPPORT SYSTEM TRADEOFFS			X	
		303.2.3 SYSTEM TRADEOFFS		X	X	
		303.2.4 READINESS SENSITIVITIES		X	X	
		303.2.5 MANPOWER AND PERSONNEL TRADEOFFS		X	X	X
		303.2.6 TRAINING TRADEOFFS		X	X	X
		303.2.7 LEVEL OF REPAIR ANALYSIS			X	X
		303.2.8 DIAGNOSTIC TRADEOFFS		X	X	
		303.2.9 COMPARATIVE EVALUATIONS			X	
		303.2.10 ENERGY TRADEOFFS		X	X	X
		303.2.11 SURVIVABILITY TRADEOFFS		X	X	
		303.2.12 TRANSPORTABILITY TRADEOFFS		X	X	
		303.2.13 SUPPORT FACILITY TRADEOFFS		X	X	

VI-8801-015-T11
MIL-STD-1388-1A

TABLE I. Index of Logistic Support Analysis Tasks. - Continued

TASK SECTION	PURPOSE OF TASK SECTION	TASK/SUBTASK	INFLUENCE *		
			SYS/EQUIP DESIGN	SUPPLY SYS DESIGN	LOG REQTS DE TER-MINATION
400 - DETERMINATION OF LOGISTIC SUPPORT RESOURCE REQUIREMENTS	TO IDENTIFY THE LOGISTIC SUPPORT RESOURCE REQUIREMENTS OF THE NEW SYSTEM IN ITS OPERATIONAL ENVIRONMENT(S) AND TO DEVELOP PLANS FOR POST PRODUCTION SUPPORT	401 - TASK ANALYSIS			
		401.2.1 TASK ANALYSIS			X
		401.2.2 ANALYSIS DOCUMENTATION			X
		401.2.3 NEW/CRITICAL SUPPORT RESOURCES			X
		401.2.4 TRAINING REQUIREMENTS AND RECOMMENDATIONS			X
		401.2.5 DESIGN IMPROVEMENTS	X	X	
		401.2.6 MANAGEMENT PLANS			X
		401.2.7 TRANSPORTABILITY ANALYSIS	X	X	
		401.2.8 PROVISIONING REQUIREMENTS			X
		401.2.9 VALIDATION	X	X	X
		401.2.10 ILS OUTPUT PRODUCTS	X	X	X
		401.2.11 LSAR UPDATES	X	X	X
		401.2.12 PROVISIONING SCREENING			
		402 - EARLY FIELDING ANALYSIS			
		402.2.1 NEW SYSTEM IMPACT			X
		402.2.2 SOURCES OF MANPOWER AND PERSONNEL SKILLS			X
		402.2.3 IMPACT OF RESOURCE SHORTFALLS			X
		402.2.4 COMBAT RESOURCE REQUIREMENTS			X
		402.2.5 PLANS FOR PROBLEM RESOLUTION			X
		403 - POST PRODUCTION SUPPORT ANALYSIS			
		403.2 POST PRODUCTION SUPPORT PLAN		X	X
500 - SUPPORTABILITY ASSESSMENT	TO ASSURE THAT SPECIFIED REQUIREMENTS ARE ACHIEVED AND DEFICIENCIES CORRECTED	501 - SUPPORTABILITY TEST, EVALUATION, AND VERIFICATION			
		501.2.1 TEST AND EVALUATION STRATEGY	X	X	X
		501.2.2 SYSTEM SUPPORT PACKAGE COMPONENT LIST	X	X	X
		501.2.3 OBJECTIVES AND CRITERIA	X	X	X
		501.2.4 UPDATES AND CORRECTIVE ACTIONS	X	X	X
		501.2.5 SUPPORTABILITY ASSESSMENT PLAN (POST DEPLOYMENT)	X	X	X
		501.2.6 SUPPORTABILITY ASSESSMENT (POST DEPLOYMENT)	X	X	X

MIL-STD-1388-1A

TASK 103

PROGRAM AND DESIGN REVIEWS

103.1 PURPOSE. To establish a requirement for the performing activity to plan and provide for official review and control of released design information with LSA program participation in a timely and controlled manner, and to assure that the LSA program is proceeding in accordance with the contractual milestones so that the supportability and supportability related design requirements will be achieved.

103.2 TASK DESCRIPTION

103.2.1 Establish and document design review procedures (where procedures do not already exist) which provide for official review and control of released design information with LSA program participation in a timely and controlled manner. These procedures shall define accept/reject criteria pertaining to supportability requirements, the method of documenting reviews, the types of design documentation subject to review, and the degree of authority of each reviewing activity.

103.2.2 Formal review and assessment of supportability and supportability related design contract requirements shall be an integral part of each system/equipment design review (e.g., system design review (SDR), preliminary design review (PDR), critical design review (CDR), etc.) specified by the contract. The performing activity shall schedule reviews with subcontractors and suppliers, as appropriate, and inform the requiring authority in advance of each review. Results of each system/equipment design review shall be documented. Design reviews shall identify and discuss all pertinent aspects of the LSA program. Agendas shall be developed and coordinated to address at least the following topics as they apply to the program phase activity and the review being conducted.

- a. LSA conducted by task and WBS element.
- b. Supportability assessment of proposed design features including supportability, cost, and readiness drivers and new or critical logistic support resource requirements.
- c. Corrective actions considered, proposed, or taken, such as:
 - (1) Support alternatives under consideration.
 - (2) System/equipment alternatives under consideration.
 - (3) Evaluation and tradeoff analysis results.
 - (4) Comparative analysis with existing systems/equipment.
 - (5) Design or redesign actions proposed or taken.

- d. Review of supportability and supportability related design requirements (with review of specifications as developed).
- e. Progress toward establishing or achieving supportability goals.
- f. LSA documentation required, completed, and scheduled.
- g. Design, schedule, or analysis problems affecting supportability.
- h. Identification of supportability related design recommendations to include a description of the recommendation; whether or not it has been approved or is pending; rationale for approval (e.g., cost savings, maintenance burden reductions, supply support reductions, reliability improvements, safety or health hazard reduction etc.).
- i. Other topics and issues as appropriate.

103.2.3 Formal review and assessment of supportability and supportability related design contract requirements shall be an integral part of each system/equipment program review specified by the contract. Program reviews include, but are not limited to, ILS management team meetings, reliability program reviews, maintainability program reviews, technical data reviews, test integration reviews, training program reviews, human engineering program reviews, system safety program reviews and supply support reviews. The performing activity shall schedule program reviews with subcontractors and suppliers, as appropriate, and inform the requiring authority in advance of each review. Results of each system/equipment program review shall be documented. Program reviews shall identify and discuss all pertinent aspects of the LSA program. Agendas shall be developed and coordinated to address at least the topics listed under 103.2.2 as they apply to the program phase activity and the review being conducted.

103.2.4 The LSA program shall be planned and scheduled to permit the performing activity and the requiring authority to review program status. The status of the LSA program shall be assessed at LSA reviews specified by the contract. The performing activity shall schedule LSA reviews with subcontractors and suppliers, as appropriate, and inform the requiring authority in advance of each review. Results of each LSA review shall be documented. LSA reviews shall identify and discuss all pertinent aspects of the LSA program to a more detailed level than that covered at design and program reviews. Agendas shall be developed and coordinated to address at least the topics listed under 103.2.2 as they apply to the program phase activity and the review being conducted.

103.2.5 LSA guidance conferences shall be planned and scheduled to permit the performing activity and the requiring authority to formally assess the relationship of the LSA documentation, task milestones and funding levels contractually required. The performing activity shall schedule a LSA guidance

conference with the subcontractors and suppliers, as appropriate, and inform the requiring authority in advance of each conference. Results of each LSA guidance conference shall be documented. Agendas shall be developed and coordinated to address at least the topics listed under 102.2.1 as they apply to the program phase. Additional functional area guidance conferences shall be held as part of the LSA guidance conference or scheduled to occur after the LSA guidance conference. A requirement for the additional conferences to be held shall be scheduled during the LSA guidance conference or as part of the LSA plan. A list of candidate conferences is as follows:

- a. Provisioning Guidance Conference.
- b. Provisioning Preparedness Review Conference.
- c. Long Lead Time Item Provisioning Conference.
- d. Provisioning Conference.
- e. Interim Support Items Conference.
- f. General Conference.

Refer to Appendix B of this document for conference definitions.

103.3 TASK INPUT

- 103.3.1 Identification and location of design, program, and LSA reviews required.*
- 103.3.2 Advance notification requirements to the requiring authority of all scheduled reviews.*
- 103.3.3 Recording procedures for the results of the reviews.*
- 103.3.4 Identification of requiring authority and performing activity follow-up methods on review of open items.*
- 103.3.5 Delivery identification of any data item required.*

103.4 TASK OUTPUT

- 103.4.1 Design review procedures which provide for official review and control of released design information with LSA program participation in a timely and controlled manner. (103.2.1)
- 103.4.2 Agendas for and documented results of each design review to include design recommendations identified in accordance with 103.2.2h. (103.2.2)

MIL-STD-1388-1A

103.4.3 Agendas for and documented results of each system/equipment program review. (103.2.3)

103.4.4 Agendas for and documented results of each system/equipment LSA review (103.2.4).

103.4.5 Schedules and agendas for, and documented results of, each provisioning related activity or conference (103.2.5).

MIL-STD-1388-1A
April 11, 1983

TASK SECTION 200
MISSION AND SUPPORT SYSTEMS DEFINITION

MIL-STD-1388-1A

204.4 TASK OUTPUT

204.4.1 Recommended design specifications to achieve improvements on the new system/equipment. (204.2.1)

204.4.2 Updates to the design objectives established as new system/equipment alternatives become better defined. (204.2.2)

204.4.3 Any additional finding requirements, risks associated with the design objectives established, any development and evaluation approaches needed to verify the improvement potential, and any cost or schedule impacts to implement potential improvements. (204.2.3)

TASK 205

SUPPORTABILITY AND SUPPORTABILITY RELATED DESIGN FACTORS

205.1 PURPOSE. To establish (1) quantitative supportability characteristics resulting from alternative design and operational concepts, and (2) supportability and supportability related design objectives, goals and thresholds, and constraints for the new system/equipment for inclusion in program approval documents, system/equipment specifications, other requirements documents, or contracts as appropriate.

205.2 TASK DESCRIPTION

205.2.1 Identify the quantitative operations and support characteristics resulting from alternative design and operational concepts for the new system/equipment. Operational characteristics shall be expressed in terms of crew size per system, aptitude and skill requirements of each job in the crew, and performance standards for each task. Supportability characteristics shall be expressed in terms of feasible support concepts, estimates of manpower requirements, aptitude and skill requirements for each job associated with the system, performance standards for each task, R&M parameters, system readiness, O&S cost, and logistic support resource requirements. Both peacetime and wartime conditions shall be included.

205.2.2 Conduct sensitivity analysis on the variables associated with the supportability, cost and readiness drivers identified for the new system/equipment.

205.2.3 Identify any hardware or software for which the Government will not or may not have full design rights due to constraints imposed by regulations or laws limiting the information the contractor must furnish because of proprietary or other source control considerations. Include alternatives and cost, schedule and function impacts.

205.2.4 Establish supportability, cost, environmental impact, and readiness objectives for the new system. Identify the risks and uncertainties involved in achieving the objectives established. Identify any risks associated with new technology planned for the new system/equipment.

205.2.5 Establish supportability and supportability related design constraints for the new system/equipment for inclusion in specifications, other requirements documents, or contracts as appropriate. The design constraints will address, but are not limited to, those constraints related to hazardous material, hazardous waste, and environmental pollutants. These constraints shall include both quantitative and qualitative constraints. Document the quantitative constraints in the LSAR or equivalent format approved by the requiring authority.

205.2.6 Identify any constraints that preclude adoption of a NATO system/equipment to satisfy the mission need.

205.2.7 Update the supportability, cost, and readiness objectives and establish goals and thresholds as new system/equipment alternatives become better defined.

303.2.2 Conduct evaluations and tradeoffs between the support system alternatives identified for each system/equipment alternative (Task 302). For the selected support system alternative(s), identify and document any new or critical logistic support resource requirements. Any restructured personnel job classification shall be identified as a new resource.

303.2.3 Conduct evaluations and tradeoffs between design, operations, and support concepts under consideration.

303.2.4 Evaluate the sensitivity of system readiness parameters to variations in key design and support parameters such as R&M, spares budgets, resupply time, and manpower and personnel skill availability.

303.2.5 Estimate and evaluate the manpower and personnel implications of alternative system/equipment concepts in terms of total numbers of personnel required, job classifications, skill levels, and experience required. This analysis shall include organizational overhead requirements, error rates, and training requirements.

303.2.6 Conduct evaluations and tradeoffs between design, operations, training, and personnel job design to determine the optimum solution for attaining and maintaining the required proficiency of operating and support personnel. Training evaluations and trades shall be conducted and shall consider shifting of job duties between job classifications, alternative technical publications concepts, and alternative mixes of formal training, on-the-job training, unit training, and use of training simulators.

303.2.7 Conduct level of repair analysis (LORA) in accordance with MIL-STD-1390, commensurate with the level of design, operation, and support data available. Identify Source, Maintenance, and Recoverability (SMR) characteristics from the LORA for those items identified as provisioned item candidates.

303.2.8 Evaluate alternative diagnostic concepts to include varying degrees of built-in-test (BIT), off-line-test, manual testing, automatic testing, diagnostic connecting points for testing, and identify the optimum diagnostic concept for each system/equipment alternative under consideration.

303.2.9 Conduct comparative evaluations between the supportability, cost, and readiness parameters of the new system/equipment and existing comparative systems/equipment. Assess the risks involved in achieving the supportability, cost, and readiness objectives for the new system/equipment based upon the degree of growth over existing systems/equipment.

303.2.10 Conduct evaluations and tradeoffs between system/equipment alternatives and energy requirements. Identify the petroleum, oil, and lubricant (POL) requirements for each system/equipment alternative under consideration and conduct sensitivity analyses on POL costs.

MIL-STD-1388-1A

303.2.11 Conduct evaluations and tradeoffs between system/equipment alternatives and survivability and battle damage repair characteristics in a combat environment.

303.2.12 Conduct evaluations and tradeoffs between system/equipment alternatives and transportability requirements. Identify the transportability requirements for each alternative under consideration and the limiting constraints, characteristics, and environments on each of the modes of transportation.

303.2.13 Conduct evaluations and tradeoffs between system/equipment alternatives and support facilities (including power/utilities and pavements) requirements. Identify the facility requirements for each support system alternative under consideration and the limiting constraints, characteristics, and environment on each type of facility.

303.3 TASK INPUT

303.3.1 Delivery identification of any data item required.*

303.3.2 Method of review and approval of identified evaluations and tradeoffs to be performed, evaluation criteria, analytical relationships and models to be used, analysis results, and the sensitivity analyses to be performed.*

303.3.3 Specific evaluations, tradeoffs, or sensitivity analyses to be performed, if applicable.*

303.3.4 Specific analytical relationships or models to be used, if applicable.*

303.3.5 Any limits (numbers or skills) to operator or support personnel for the new system/equipment.*

303.3.6 Manpower and personnel costs for use in appropriate tradeoffs and evaluations which include costs related to recruitment, training, retention, development, and washout rates.* (303.2.2, 303.2.5, 303.2.6)

303.3.7 Support alternatives for the new system/equipment from Task 302.

303.3.8 Description of system/equipment alternatives under consideration.

303.3.9 Supportability and supportability related design objectives, goals and thresholds, and constraints for the new system/equipment from Task 205.

303.3.10 Historical CER/PER that exist which are applicable to the new system/equipment.

303.3.11 Job and task inventory for applicable personnel job classifications. (303.2.2, 303.2.5, 303.2.6)

303.3.12 The results of the human engineering task performance analysis, prepared in accordance with MIL-STD-1478. (303.2.3, 303.2.4, 303.2.5, 303.2.6)

303.4 TASK OUTPUT

303.4.1 For each evaluation and tradeoff performed under this task:

- a. Identification of the evaluation criteria, analytical relationships and models used, selected alternatives, appropriate sensitivity analysis results, evaluation and tradeoff results, and any risks involved.
- b. Tradeoff and evaluation updates, as applicable.

303.4.2 Recommended support system alternatives for each system/equipment alternative and identification of new or critical logistic support resource requirements. (303.2.2)

303.4.3 Recommended system/equipment alternatives based on cost, schedule, performance, readiness, and supportability factors. (303.2.3)

303.4.4 System/equipment readiness sensitivity to variations in key design and support parameters. (303.2.4)

303.4.5 Estimates of total manpower and personnel requirements for alternative system/equipment concepts. (303.2.5)

303.4.6 Optimum training and personnel job design for attaining and maintaining the required proficiency of operating and support personnel.(303.2.6)

303.4.7 Level of repair analysis results. (303.2.7)

303.4.8 Optimum diagnostic concept for each system/equipment alternative under consideration. (303.2.8)

303.4.9 Comparisons between the supportability, cost, and readiness parameters of the new system/equipment and existing comparable systems/equipment. (303.2.9)

303.4.10 Tradeoff results between system/equipment alternatives and energy requirements. (303.2.10)

303.4.11 Tradeoff results between system/equipment alternatives and survivability and battle damage repair characteristics. (303.2.11)

303.4.12 Tradeoff results between system/equipment alternatives and transportability requirements. (303.2.12)

303.4.13 Tradeoff results between system/equipment alternatives and facilities requirements (303.2.13)

MIL-STD-1388-1A
April 11, 1983

TASK SECTION 400
DETERMINATION OF LOGISTIC SUPPORT RESOURCE REQUIREMENTS

40 Reprinted without change

MIL-STD-1388-1A
TASK 401
TASK ANALYSIS

401.1 PURPOSE. To analyze required operations and maintenance tasks for the new system/equipment to:

- a. Identify logistics-support resource requirements for each task..
- b. Identify new or critical logistic support resource requirements.
- c. Identify transportability requirements.
- d. Identify support requirements which exceed established goals, thresholds, or constraints.
- e. Provide data to support participation in the development of design alternatives to reduce O&S costs, optimize logistic support resource requirements, or enhance readiness.
- f. Provide spirce data for preparation of required ILS documents (technical manuals, training programs, manpower and personnel lists, etc).

401.2 TASK DESCRIPTION

401.2.1 Conduct a detailed analysis of each operation, maintenance and support task contained in the task inventory (Task 301) and determine the following:

- a. Logistic support resources required (considering all ILS elements) to perform the task.
- b. Task frequency, task interval, elapsed time, and manhours in the system/equipment's intended operational environment and based on the specified annual operating base.
- c. Maintenance level assignment based on the established support plan (Task 303).
- d. Environmental impact of the tasks including use of hazardous materials, generation of hazardous waste, and release of air and water pollutants.

401.2.2 Document the results of Task 401.2.1 in the LSAR or equivalent format approved by the requiring authority.

401.2.3 Identify new or critical logistic support resources required to perform each task, and hazardous materials, hazardous waste, and environmental impact requirements associated with these resources. New resources are those which require development to operate or maintain the new system/equipment. These can include support and test equipment, facilities, new or special transportation systems, new computer resources, and new repair, test., or inspection techniques or procedures to support new design plans or technology. Critical resources are those which are not new but require special management

attention due to schedule constraints, cost implications, or known scarcities. Unless otherwise required, document new and modified logistic support resources in the LSAR, or equivalent documentation approved by the requiring authority, to provide a description and justification for the resource requirement.

401.2.4 Based upon the identified task procedures and personnel assignments, identify training requirements and provide recommendations concerning the best mode of training (formal classroom, on-the-job, or both) and the rationale for the recommendations. Document the results in the LSAR or equivalent format approved by the requiring authority.

401.2.5 Analyze the total logistic support resource requirements for each task and determine which tasks fail to meet established supportability or supportability related design goals or constraints for the new system/equipment. Identify tasks which can be optimized or simplified to reduce O&S costs, optimize logistic support resource requirements, reduce environmental impact including use of hazardous materials, generation of hazardous waste, release of air and water pollutants, and environmental impact, or enhance readiness. Propose alternative designs and participate in the development of alternative approaches to optimize and simplify tasks or to bring task requirements within acceptable levels.

401.2.6 Based upon the identified new or critical logistic support resources, determine what management actions can be taken to minimize the risks associated with each new or critical resource. These actions could include development of detailed tracking procedures, or schedule and budget modifications. Managers and program decision authorities shall consider the desirability and effectiveness of integrating Spares Acquisition Integrated with Production (SAIP) when the end item is, or will be, in production.

401.2.7 Conduct a transportability analysis on the system/equipment and any sections thereof when sectionalization is required for transport. When the general requirements of MIL-STD-1366 limitations are exceeded, document the transportability engineering characteristics in the LSAR, or equivalent format approved by the requiring authority. Participate in the development of design alternatives when transportability problem areas are surfaced.

401.2.8 For those support resources requiring initial provisioning, document the provisioning technical documentation (PTD) in the LSAR, or equivalent format approved by the requiring authority. The development and maintenance of the PTD shall be scheduled to ensure availability of information for tasks such as Level of Repair Analysis (LORA), Life Cycle Cost (LCC) analysis, and the delivery of PTD requirements as spelled out in the SOW and contract CDRLs. The PTD contained in the LSAR shall include all required documentation and topdown/breakdown visibility for assemblies, subassemblies and bit and piece components for the system being provisioned. Engineering Data For Provisioning (EDFP) data item description shall be used for initial provisioning of support items when MIL-T-31000 has been excluded from the contract.

401.2.9 Validate the key information documented in the LSAR through performance of operations and maintenance tasks on prototype equipment. This validation shall be conducted using the procedures and resources identified during the performance of 401.2.1 and updates shall be made where required.

Validation requirements shall be coordinated with other system engineering demonstrations and tests (e.g., maintainability demonstrations, reliability and durability tests) to optimize validation time and requirements.

401.2.10 Prepare output summaries and reports to satisfy ILS documentation requirements as specified by the requiring authority. These shall include all, pertinent data contained in the LSAR at the time of preparation.

401.2.11 Update the data in the LSAR as better information becomes available and as applicable input data from other system engineering programs is updated. Following delivery and acceptance of the initial provisioning data, the performing activity shall notify the requiring authority of approved changes to the provisioning data via design change notices (DCN) with supporting EDPF.

401.2.12 Identify provisioning and other preprocurement data to be submitted for government screening in order to facilitate support system standardization, preprovisioning screening, and item entry control reviews.

401.3 TASK INPUT

401.3.1 Identification of system/equipment hardware and software with which this analysis will be performed.

401.3.2 Identification of indenture levels to which this analysis will be carried.

401.3.3 Identification of the levels of maintenance which will be documented during performance of this task.

401.3.4 Known or projected logistic support resource shortages.

401.3.5 Schedule and budget ceilings and targets.

401.3.6 Any supplemental documentation requirements over and above the LSAR data records (e.g., transportability clearance diagrams, and time lines).

401.3.7 Delivery identification of any data item required.

401.3.8 Information available from the requiring authority relative to:

- a. Existing and planned personnel skills, capabilities, and programs of instruction.

MIL-STD-1388-1A

- b. Lists of standard support and test equipment.
- c. Facilities available.
- d. Training devices available.
- e. Existing transportation systems and capabilities.

401.3.9 Description of personnel capabilities (target audience) intended to operate and maintain the new system/equipment at each level of maintenance.

401.3.10 Any limits (numbers or skills) to operators or support personnel for the new system/equipment.

401.3.11 Annual operating basis for task frequencies.

401.3.12 Operations, maintenance and support task requirements from Task 301.

401.3.13 Results of human engineering task performance analysis.

401.3.14 Recommended support plan for the system/equipment from Task 303.

401.3.15 Supportability and supportability related design goals and requirements from Task 205.

401.3.16 Products developed under MIL-T-31000 to support initial provisioning of support items. (401.2.8 and 401.2.11)

401.3.17 Details to be specified in the appropriate contractual documents will include service peculiar LSA-036 header data element definition and media format instructions. (Subtask 401.2.8)

401.4 TASK OUTPUT

401.4.1 Completed LSAR data on system/equipment hardware and software and to the indenture level specified by the requiring authority, or equivalent format approved by the requiring authority.

401.4.2 Identification of new or critical logistic support resources required to operate, maintain, and support the new system. (401.2.3)

401.4.3 Alternative design approaches where tasks fail to meet established goals and constraints for the new system/equipment or where the opportunity exists to reduce O&S costs, optimize logistic support resource requirements, or enhance readiness. (401.2.5)

401.4.5 Identification of management actions to minimize the risks associated with each new or critical logistic support resource requirement. (401.2.6)

401.4.6 Validation of key information documented in the LSAR. (401.2.9)

401.4.7 Output summaries and reports as specified by the requiring authority containing all pertinent data contained in the LSAR at the time of preparation. (401.2.10)

401.4.8 Updated LSAR data as better information becomes available and as applicable input data from other system engineering programs is updated.

401.4.9 Identification of appropriate parts and National Stock Numbers (NSN), configuration status and parts sources based on provisioning data submitted for government screening. Screening results will be included within the requested provisioning technical documentation as called out-by Subtasks 401.2.8, and 401.2.11. (401.2.12)

Reprinted without change

57

PRODUCTION/DEPLOYMENT/POST PRODUCTION PHASE

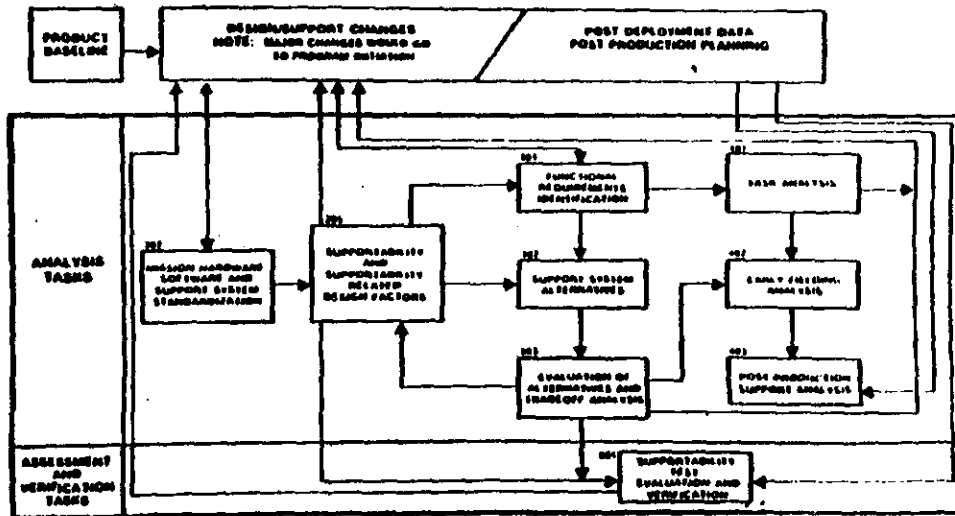

- NOTES
- 1 TASKS 101, 102 AND 103 ARE MANAGEMENT ACTIVITIES THAT ARE AN INTEGRAL PART OF THE LSA PROCESS IMPLICITLY NOT SHOWN IN THIS FIGURE
 - 2 REFER TO TABLE 10 FOR SUSTAIN APPLICABILITY BY PROGRAM PHASE
 - 3 TASKS 100 AND 103 PROVIDE DATA TO RS MANAGEMENT

FIGURE 3. Logistic Support Analytic Process Flow Chart

MIL-STD-1388-1A
April 11, 1983

MIL-STD-1388-1A
APPENDIX A

APPENDIX A

APPLICATION GUIDANCE FOR IMPLEMENTATION OF LOGISTIC
SUPPORT ANALYSIS PROGRAM REQUIREMENTS

10. SCOPE

10.1 General. This appendix provides rationale and guidance for the selection and tailoring of LSA tasks in this standard. This appendix is to be used to tailor LSA requirements in the most cost effective manner to meet program objectives. However, it is not to be referenced or implemented in contractual documents. No requirements are contained in this appendix. The users of this appendix may include the Department of Defense contracting activity, Government in-house activity, and prime contractor or subcontractor, who wishes to impose LSA tasks upon a supplier.

10.2 How to Use this Appendix. This appendix provides guidance on structuring LSA programs (paragraph 40) and on applying the individual task and subtask requirements (paragraph 50). The user should first review the major considerations affecting the development of the LSA program contained in paragraph 40 and then refer to the appropriate parts of paragraph 50 based on the tasks and subtasks selected.

20. APPLICABLE DOCUMENTS

20.1 Government documents.

Military Standards

MIL-STD-680	Standardization Program Requirements for Defense Acquisitions.
MIL-STD-965	Parts Control Program.
MIL-STD-1629	Procedures for Performing a Failure Mode, Effects, and Criticality Analysis.
MIL-STD-1388-2	DOD Requirements for a Logistic Support Analysis Record.
MIL-T-31000	Technical Data Package, General Specifications For
MIL-STD-100	Engineering Drawing Practices

MIL-STD-1388-1A
APPENDIX A

Other Documents

DODD 5000.1	Defense Acquisition
DODI 5000.2	Defense Acquisition Management Policies and Procedures

20.1.1 Service-specific guidance. Appropriate service specific guidance may be necessary to supplement the general guidance provided in this appendix. When a provisioning activity has comprehensive printed guidance that a contractor must follow and when it is too lengthy to include in a statement of work, the governing document for the guidance should be attached as an exhibit to the contract and referenced in the Statement of Work (SOW). Examples of governing documents are regulations, instructions, orders, and pamphlets.

30. DEFINITIONS

30.1 General. Key terms used in this appendix are defined in the Glossary, Appendix B.

40. GENERAL APPLICATION GUIDANCE FOR LOGISTIC SUPPORT ANALYSIS PROGRAMS

40.1 LSA Process. LSA is an iterative and multidisciplinary activity with many interfaces. The LSA process can be divided into two general parts: (a) analysis of supportability, and (b) assessment and verification of supportability. The iterative nature of this process and the input - output relationship of the interfaces change with the acquisition phases as described below.

40.1.1 Analysis of Supportability. This portion of the LSA process commences at the system level to affect design and operational concepts; identify gross logistic support resource requirements of alternative concepts; and to relate design, operational, and supportability characteristics to system readiness objectives and goals. The system level analysis is characterized by use studies, comparative analysis and driver identification, identification of technological opportunities, and tradeoffs between support, operational, and design concepts and between alternative support concepts such as organic versus contractor support, built-in versus external test capability, and varying numbers of maintenance levels. Once system level tradeoffs are made, the analysis shifts to lower system indentures and toward support system optimization within the framework established by the system level analysis. This analysis defines the logistic support resource requirements of the system through an integrated analysis of all operator and maintenance functions and tasks to determine task frequencies, task times, personnel and skill requirements, supply support requirements, etc., to include all elements of ILS. Optimization is achieved at this level through allocation of functions and tasks to specific maintenance levels, repair versus discard analyses, RCM analyses, and formulating design recommendations to optimize maintenance times and logistic support resource requirements. Data from this level of the LSA is used as direct input into the development of data products associated with each ILS element such as provisioning

MIL-STD-1388-1A
APPENDIX A

lists, personnel and training requirements, and technical manuals. This assures compatibility between ILS element documents and permits common use of data which apply to more than one logistic element.

40.1.2 Assessment and Verification. This part of the LSA process is conducted throughout the system/equipment's life cycle to demonstrate, within stated confidence levels, the validity of the analysis and products developed from the analysis, and to adjust the analysis results and products as required. This part of the process starts with early planning for verification of support concepts and continues through development, acquisition, deployment, and operations to include assessment and verification of post deployment support.

40.1.3 Interfaces. Some of the major LSA activities where interfaces play a key role are listed below along with the interfacing activities:

- a. Comparative Analysis (Task 203). Interfacing activities-human engineering, reliability, maintainability, safety, design engineers and ILS element managers.
- b. Functional Requirements Identification (Task 301). Interfacing activities-design engineering, reliability, maintainability, human engineering, safety and ILS element managers.
- c. Tradeoff Analysis (Task 303). Interfacing activities-design engineering, reliability, maintainability, safety, human engineering, cost estimating, and ILS element managers.
- d. Task Analysis (Task 401). Interfacing activities-reliability, maintainability, human engineering, and safety.
- e. Resource Requirements Identification (Task 401). Interfacing activities-design engineering, human engineering, and ILS element managers.

Figure 3a shows, in more detail, these interfaces and the information flow from the standpoint of the supporting military standards. Coordination of these interfaces is a major management challenge which requires final resolution at the working level in some cases. The subtasks in this standard are structured to facilitate assignment of applicable subtasks to the community most directly involved without loss of overall task integrity. For a specific acquisition program, LSA interfaces will be described in the LSAP (Task 102) which should be reviewed to assure that input-output relationships, responsibilities, and timing of activities are properly addressed to prevent overlap and duplication. The following general guidance may be useful in addressing the interface problem.

40.1.3.1 Inputs and Outputs for System Level LSA. Some of the system level LSA involves system analysis/engineering at the hardware-operating-support trade level (Subtask 303.2.3). System level LSA is an input to and subset of these trades and is in turn a collection, synthesis, and "system" analysis of

MIL-STD-1388-1A
APPENDIX A

inputs from various specialized areas. Figure 4 shows some of these major relationships in input-output form. The outputs from the system level LSA impact the interfacing activities in that they constitute boundary conditions or goals for specialized engineering programs and ILS element concepts and plans.

40.1.3.2 Refinement and Extension of the System Level LSA. As development progresses, the LSA is iterated and extended to lower in-denture levels with the input-output concept described above still functioning. Boundary conditions, constraints, and objectives are refined and expanded based on inputs from specialized engineering and ILS element areas. Additionally, the support system is optimized within the boundaries and objectives established. Specific subtask tradeoffs within engineering specialties and ILS elements are conducted to provide specific boundaries for follow-on efforts. These would include the BIT versus external test trades (Subtask 303.2.8) and training trades (Subtask 303.2.6).

SUPPORTABILITY STANDARDS INFORMATION RELATIONSHIPS

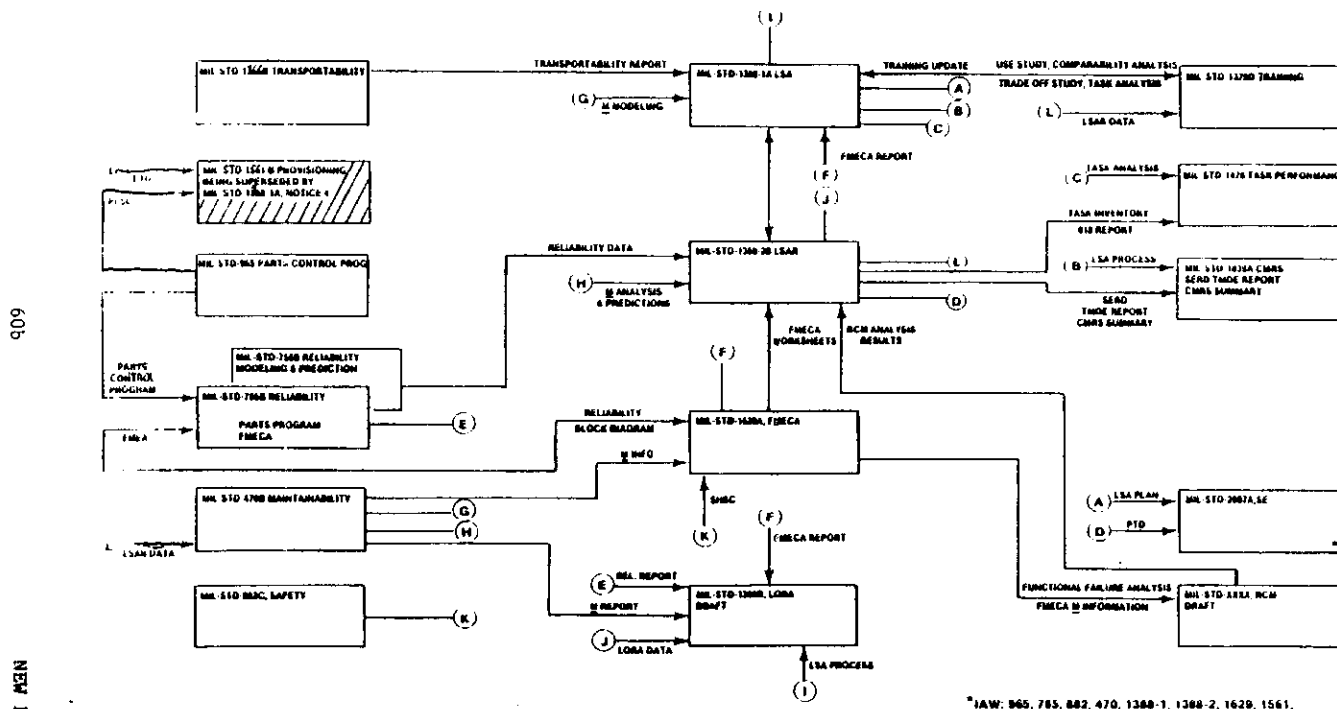

*IAW: 965, 785, 882, 470, 1388-1, 1388-2, 1629, 1561.

Figure 3a. Supportability Standards Information Relationships

60b

NEW PAGE

40.4.2 Preparing LSA RFP Requirements. The RFP is normally the first formal communication between the Government and industry. It is, therefore, a key document in the acquisition process. Industry interprets an RFP to be an expression of all the items of importance to the Government since it will be around these items that a contract will be written. Industry taxes its ingenuity to provide a competitive product that meets the stated requirements. This section discusses some suggested practices in preparing the RFP.

40.4.2.1 Broad Versus Specifics. Give the total support picture as early as possible. Structure the RFP to pose the broad problem to be addressed by the LSA program and provide information on absolutely necessary analysis subtasks and data required. Don't go into unnecessary detail in establishing requirements at too early a time, especially if the scenarios are conceptual and design is still only crudely defined. Describe the freedom the bidder has for feedback. The bidder can then draw from experience and innovation to fine tune the requirements. Bidder feedback should be considered as recommendations only to preclude legal problems. Don't destroy credibility by asking for inputs which are inconsequential in source selection or to the program as a whole.

40.4.2.2 Interweave Supportability Requirements and Constraints. Structure the RFP in such a way that supportability constraints and supportability related design requirements are interwoven into the appropriate system/development specification sections or other system/equipment description. This gives everyone involved with the design an appreciation of the supportability constraints and requirements. A properly structured RFP requires readiness and supportability inputs into many sections of the RFP. Consequently, more than just the logistics portions of the SOW and contract data requirements list must be addressed. The major areas for supportability input into an RFP include the following:

- a. Section B, Supplies/Services and Prices. Establish supportability work efforts and requirements as separate contract line items where possible.
- b. Section C, Description/Specifications. Enter supportability work efforts and supportability design requirements.
- c. Section F, Deliveries or Performance. Consider statement that delivery of the system/equipment will not be accepted without concurrent delivery of required logistic products.
- d. Section H, Special Provisions. Consider inclusion of supportability incentives such as a design to life cycle cost goal.
- e. Section I, General Provisions. Ensure that applicable Defense Acquisition Regulation clause(s) on rights in technical data and computer software are included.

MIL-STD-1388-1A
APPENDIX A

f. Section L, Instructions and Conditions, and Notices to Offerors. Ensure proposal preparation instructions relative to supportability aspect of the RFP are detailed and clearly written. Consider a separate proposal section for supportability.

g. Section M, Evaluation Factors for Award. Ensure sufficient weighting is given to supportability.

40.4.2.3 Relative Importance of Requirements. State the order of importance of the supportability related parameters being requested to the source selection criteria. This permits the LSA team to make an honest effort to provide the best LSA subtask selection for the least cost. For example, indicate that R&M are to be of high priority, and size and weight to be of low priority only if it is true; not when the size and weight requirements are inflexible and paramount. Identify any requirements which are soft, and in which the requester would consider slight reductions for other significant benefits. Contractors must be made aware of their responsibility to obligate their vendor/subcontractors to fulfill the applicable requirements, procedures, terms, conditions, and data requirements stated within this document.

40.4.2.4 Support Related Design Drivers. Consistent with the degree of design freedom, ask the bidder to identify those design attributes which may prove to be the key influencing factors in readiness, acquisition cost, O&S cost, and logistic support resource demands. Have the bidder identify the LSA subtasks that will be used to analyze these requirements.

40.4.2.5 Alternate Support Concepts. It is DOD policy to encourage innovative analysis approaches which can be used to pinpoint potential readiness, O&S cost, and supportability benefits. When options are not foreclosed due to prior investments, the RFP should allow the contractor to suggest analysis approaches to reduce support costs by changing the way an item is supported. This does not mean that a contractor should be permitted to violate the basic requirements; on the contrary, the contractor should be made to understand that proposed alternatives must be totally compliant with the requirements. However, the contractor should be permitted to offer alternatives which go beyond basic compliance. It should be possible to favorably evaluate a contractor who proposes LSA techniques that can be used to identify system/equipment design that meets requirements together with an innovative alternate support scheme, if the alternate scheme meets support requirements and realistically promises lower support costs.

40.4.2.6 Evaluation Methods and Models. The RFP should indicate how the requester plans to evaluate the degree to which LSA requirements have been satisfied. The proof of compliance with such requirements should be as straightforward as that for compliance with performance requirements. The contractor should be told what technically auditable information he needs to provide to permit such evaluations. It is imperative that data structure, fixed constraints, and defining statements be identical for all competing contractors. If contractors are required to perform modeling, identical models tailored to the competition and the specifics of the program should be provided to all, and all bidders should be required to use them.

MIL-STD-1388-1A
APPENDIX A

40.4.2.7 Provisioning Procedures. In addition to the supply support associated requirements stated in paragraphs 40.4.2.3 - 40.4.2.6, the following information is required to identify and establish the required provisioning program. Specific provisioning requirements should be stated in the SOW for inclusion in the solicitation or contract. The provisioning requirements in conjunction with applicable DD Form 1423 series, Contract Data Requirements List, establishes requirements for schedules, identifies actions, and delineates the specific procedural and deliverable data requirements applicable to a particular solicitation or contract. If omitted in the solicitation or contract, provisioning requirements may be incorporated into the contract after the award by contract modification.

a. Provisioning Performance Schedule (PPS). Significant events and milestones can be stated in the PPS. The PPS can be included with the solicitation or contract. The PPS will be developed, updated or finalized as required at the guidance conference, and incorporated into the contract by contract modification if the contract is already awarded. The requirements not covered by the PPS may be included in the Statement of Work under LSA, when prescribed by the procuring activity. A sample PPS is shown in figure 6.

b. Provisioning Technical Documentation (PTD). The requiring authority will be responsible for requiring PTD on the DD Form 1423 series. Specific data elements to be included in each list should be as specified by the LSAR Data Requirements Form, DD Form 1949-3, Part II. The applicable Data Item Description (DID) for PTD should be cited and tailored to obtain the exact parts lists being requested. The contractor should submit the required PTD or include a Statement of Prior Submission (SPS) for those PLs previously submitted. PTD (i.e. Subtask 401.2.8) is defined in Appendix B.

c. Method of Provisioning. The Provisioning Activity should determine whether this method should be by Resident Provisioning Team (RPT), Conference Team, In House, or Logistic Support Analysis Record (LSAR). These methods are defined in Appendix B.

d. Engineering Data for Provisioning (EDFP). The Statement of Work (SOW)/contract should make reference to MIL-T-31000, Specifications for Technical Data Packages, in order to obtain product engineering drawings and commercial data to support the provisioning process (i.e. Subtask 401.2.8). The DOD preference is not to acquire a new or separate MIL-T-31000 Technical Data Package, but to use an existing contract DID to support the Provisioning Process. Generally this can be done by acquiring copies of products being developed for the MIL-T-31000 DIDs at the time of the Provisioning event for the cost of reproduction and delivery without regard to completeness of the drawing. EDFP must be obtained by citing DI-DRPR-81000, Product Drawings and Associated Lists, using a CDRL tailored to support the Provisioning Process as stated in this paragraph. The SOW/contract order of precedence for EDFP should be product engineering drawings, in process/incomplete product engineering drawings adequate for the provisioning process and finally, commercial drawings or

MIL-STD-1388-1A
APPENDIX A

associated lists. The associated DD Form 1423 series should state the following: "If product Technical Data Package (TDP) requirements have not been achieved, the contractor shall submit the available data that satisfies the SOW/contract conditions." Commercial data, when used, must be delivered by using DI-DRPR-81003, Commercial Drawings and Associated Lists. DI-ILSS-81289 may be cited for engineering data only when MIL-T-31000 requirements have been excluded from the SOW. The intent of DID DI-ILSS-81289 is to use the requirements and specifications of MIL-T-31000 DIDs without using that standard directly on the support contract. EDFP shall not be provided when the item is: (1) identified by a government specification or standard which completely describes the item including its material, dimensional mechanical and electrical characteristics, (2) identified in the Defense Integrated Data System with a type item identification of 1, 1A (K) or 1B (L) or (3) item is listed as a reference item (subsequent appearance of an item) on a parts list.

e. Design Change Notice (DCN). Design Change Notices for procurable type items should be prepared in the same format as other Provisioning Technical Documentation (PTD) or in accordance with instructions from the PA, (i.e., Subtask 401.2.11). The notices should be accompanied by EDFP and submitted within twenty-one (21) days after release of the EDFP for contractor design items and forty-two (42) days after release of the EDFP for the subcontractor supplied items. Design Change Notices for non-procurable type items should be prepared in accordance with instructions from the provisioning activity and should be supported by applicable EDFP and should be submitted within sixty (60) days after release of the EDFP. Design change conditions should be as specified in the LSAR update process or as specified by the PA. A DCN for administrative purposes or to facilitate the production control process is not acceptable. Refer to Appendix B for DCN definition.

f. Additional Provisioning Requirements. Specific provisioning requirements that have not been included in the CDRL may be requested in DD Form 1949-3, LSAR Data Requirements Form. This information establishes requirements for schedules, identifies actions, and delineates specific procedural and deliverable data requirements applicable to a particular solicitation or contract.

g. Provisioning Conference. This conference is used by the government to validate the support items and to assign technical and management codes made during the LSA process. When specified, one or more of the following articles should be available to conduct the provisioning conference:

(1) PTD.

(2) Personnel with expert technical knowledge of the and item with regard to the design, reliability and maintenance characteristics of the and item or the portion of the end item being provisioned.

(3) Sample articles for disassembly or government viewing, including required tools/test equipment and adequate workspace near sample articles, when specified by the provisioning requirements.

MIL-STD-1388-1A
APPENDIX A

- (4) LSA/level of repair analysis data as specified by the government.
- (5) Program parts selection list (PPSL) per MIL-STD-965 when a PPSL is a contract requirement.
- (6) Provisioning screening results printout, when required by the PRS.

40.4.2.8 Spares Acquisition Incorporated With Production (SAIP). This procedure places orders for installed components and spares concurrently. For vendor items, the spares order may be placed by the prime contractor on behalf of the Government or directly by the Government. The advantages obtained are timely availability of spares, integrated configuration and quality control, and quantity price breaks due to economy of scale. (i.e., Subtask 401.2.6). Contractor's Procurement Schedule for SAIP (DI-ILSS-81290) and Recommended spare Parts List for SAIP (DI-ILSS-80293) are to be placed on contract if SAIP is applied. These data items provide the information needed to employ the SAIP procedure.

40.5 Task Documentation. The development and maintenance of good documentation covering the results of LSA tasks contained in this standard serve the following purposes:

- a. Provides an audit trail of analyses performed and decisions made affecting the supportability of a system/equipment.
- b. Provides analysis results for input to follow-on analysis tasks later in the system/equipment's life cycle.
- c. Provides source data for use by ILS element functional managers and a standard method of recording ILS element data from functional managers.
- d. Provides input into materiel acquisition program documents.
- e. Helps prevent duplication of analyses.
- f. Provides an experience data base for use on future acquisition programs.

40.5.1 Individual analysis tasks performed as part of a system/equipment's LSA program may be performed by a Government activity, contractor activity, or both. Task documentation must be developed to the degree that will allow another activity to use the task results as input data to perform other LSA tasks, or as input to conduct the same task to a more detailed level in a later acquisition phase. When some tasks are performed by the Government and others are performed by a contractor, procedures must be established to provide for the data interchange between the performing activities. Tasks performed by Government activities should be documented equivalent to the applicable Data Item Description (DID) requirements to assure compatibility of documentation.

40.5.2 When LSA tasks are performed by a contractor, task documentation that is required for delivery to the Government will be specified on the CDRL, DD Form 1423, with appropriate DID's being

MIL-STD-1388-1A
APPENDIX A

cited. The CDRL will identify data and information that the contractor will be obligated to deliver under the contract. DID's are used to define and describe the data required to be furnished by the contractor. Applicable DID's that describe the data resulting from performance of the LSA tasks contained in this standard are identified in Table III. These DID's are structured to identify the maximum range of data that can be documented in a report. The requiring authority can tailor down these requirements by deleting unwanted data from Block 10 of the DD Form 1664 and making appropriate use of the CDRL. For example, if the requiring authority wants a System/Design Trade Study Report which only covers the tradeoff analysis results (Task 303) or the data from only one of the tradeoff subtasks (e.g., 303.2.7, repair level analysis), this can be accomplished through appropriate entries on the CDRL. By appropriately completing the CDRL and lining out unwanted data in Block 10 of the applicable DID's, the requiring authority can structure the deliverable data products to cost effectively meet program requirements.

PROVISIONING PERFORMANCE SCHEDULE				DATE INITIATED	REVISION	
					NUMBER	DATE
END ARTICLE				CONTRACTOR		
END ARTICLE DELIVERY DATES		SOLICITATION OR CONTRACT NUMBER		TYPE OF CONTRACT		
DATE OF FIRST DELIVERY				<input type="checkbox"/> FSD <input type="checkbox"/> PROD <input type="checkbox"/> FSD W/ PROD OPT		
DATE OF LAST DELIVERY						
NO	EVENT	ACTION AGENCY	TIMING	CALENDAR DATE		
1	CONTRACT AWARD	GOVT	CONTRACT MAILING DATE			
2	GUIDANCE CONFERENCE	GOVT AND CONTR	NLT 45 DAYS AFTER MAILING DATE OF CONTRACT			
3	DLSC SCREENING	CONTR	SUBMIT TO DLSC NOT EARLIER THAN 30 DAYS PRIOR TO SUBMITTING PTD			
4	SAP a. CANDIDATE LIST	CONTR	NLT 165 DAYS PRIOR TO CONTRACTOR'S ORDER NEED DATE			
	b. SELECTED ITEM NOTIFICATION	GOVT	NLT 30 DAYS AFTER RECEIPT OF CANDIDATE LIST			
	c. CONTRACTOR PROCUREMENT SCHEDULE PTD, SPTD SCREENING RESULTS	CONTR	NLT 90 DAYS PRIOR TO CONTRACTOR'S ORDER NEED DATE			
	d. PROVISIONING CONFERENCE	GOVT AND CONTR	NLT 60 DAYS PRIOR TO CONTRACTOR'S ORDER NEED DATE	START		
	e. PDI _s RELEASED TO CONTRACTOR	GOVT	NLT 30 DAYS PRIOR TO CONTRACTOR'S ORDER NEED DATE	FINISH		
	5	LONG LEAD ITEMS LIST (LLL) WITH SPTD AND DLSC SCREENING RESULTS a. INTERIM RELEASED ITEMS	CONTR	NLT 30 DAYS AFTER RELEASE FOR FABRICATION OR PROCUREMENT OF SPARE REPAIR PARTS		
6	b. RECOMMENDED ITEMS	CONTR	45 DAYS PRIOR TO RELEASE OF PPL			
	c. PROVISIONING CONFERENCE	GOVT AND CONTR	NLT 90 DAYS PRIOR TO CONTRACTOR'S ORDER NEED DATE	START		
	d. PDI _s RELEASED TO CONTRACTOR	GOVT	NLT 30 DAYS AFTER RECEIPT OF LLL FROM CONTRACTOR	FINISH		
	7	PTD / SPTD REQUIREMENTS	CONTR	NLT 60 DAYS PRIOR TO PROVISIONING CONFERENCE		
8	PROVISIONING CONFERENCE	GOVT AND CONTR	NLT 60 DAYS AFTER RECEIPT OF PTD - SPTD	START		
9	PDI _s w / DELIVERY SCHEDULE	GOVT	DUE TO CONTRACTOR 60 DAYS AFTER PROVISIONING CONFERENCE	FINISH		
10	ACCEPTANCE / REVISION OF DELIVERY SCHEDULE	CONTR	NLT 60 DAYS AFTER RECEIPT OF PDI _s			
11	SPARES NEED DATE	GOVT	IAW PROGRAMMING CHECKLIST BUT NLT 90 DAYS PRIOR TO OND			
12	TRAINING START DATE	GOVT				
	OPERATIONAL NEED DATE	GOVT				
REMARKS:						
APPROVED BY						
PROV CHAIRPERSON		CONTRACTOR		PROGRAM MANAGER		

FIGURE 6. Provisioning Performance Schedule

40.5.3 There is a considerable distinction between data and the documentation of data. Additionally, there is a large number of different forms of documentation for LSA data which frequently overlap. Because of these factors, LSA program data and data formatting requirements must be carefully scoped to meet program needs in a cost effective manner. Factors which affect data and documentation costs include the following:

a. Timing of preparation and delivery. Documentation or recording of data should coincide with the generation of such data in the design and analysis sequences in order that such data will not have to be recreated at added expense at a later date. Delivery of data should be postponed until actual need date in order to acquire data in its most complete form without repetitive updates.

b. Use of the data by the performing activity. The less use, the more expensive.

c. Special formatting requirements.

d. Degree of detail required.

e. Degree of research required to obtain the data.

f. Accuracy and amount of verification required.

g. Duration of responsibility for data contents.

h. Availability and accuracy of source data from which to construct documentation. For example, poorly prepared or inaccurate schematics will increase the cost of technical manuals.

40.5.4 Data and data documentation costs can be effectively controlled by the following methods:

a. Screening requirements prior to preparation of solicitation documents. Each data requirement should be reviewed for data content, end use, formatting needs, scheduled delivery, and estimated cost to eliminate duplication and assure proper integration and scheduling of requirements. This function is generally performed by ILS management.

MIL-STD-1388-1A
APPENDIX A

50.1.3 Logistic Support Analysis Plan (Task 102).

50.1.3.1 The LSAP is the basic tool for establishing and executing effective LSA program. It should effectively document what LSA tasks are to be accomplished, when each task will be accomplished, what organizational units will be responsible for their accomplishment, and how the results of each task will be used. The LSAP may be a stand alone document or may be included as part of the program's ISP when an ISP is required. Plans submitted in response to solicitation documents assist the requiring authority in evaluating the prospective performing activity's approach to and understanding, of the LSA task requirements, and the organizational structure for performing LSA tasks.

50.1.3.2 The LSAP is generally submitted in response to a solicitation document and generally becomes a part of the SOW when approved by the requiring authority. When requiring an LSAP, the requiring authority should allow the performing activity to propose additional tasks or task modifications, with supporting rationale to show overall program benefits, to those tasks contained in the solicitation document. The LSAP should be a dynamic document that reflects current program status and planned actions. Accordingly, procedures must be established for updates and approval of updates by the requiring authority when conditions warrant. Program schedule changes, test results, or LSA task results may dictate a change in the LSAP in order for it to be used effectively as a management document.

50.1.4 Program and Design Reviews (Task 103).

50.1.4.1 This task is directed toward four types of reviews; (1) review of design information within the performing activity from a supportability standpoint, (2) system/equipment design reviews, (3) formal system/equipment, program reviews, and (4) detailed LSA program reviews. These system/equipment reviews, to include provisioning conferences, should be scheduled in a manner that supports integrated engineering principals and support concepts. The first type (Subtask 103.2.1) provides supportability specialists the authority with which to manage design influence and tradeoffs. For most developers this type of review is a normal operating practice and imposition of this subtask would not impose any additional cost. This subtask is only applicable during design and design modification efforts and, therefore, should not be applied to nondevelopmental acquisition programs. Contractor procedures for this type of review would be included in the LSAP.

50.1.4.2 System/equipment design reviews and program reviews (Subtasks 103.2.2 and 103.2.3) such as preliminary design reviews, critical design reviews, and production readiness reviews are an important management and technical tool of the requiring authority. They should be specified in SOW's to assure adequate staffing and funding and are typically held periodically during an acquisition program to evaluate overall program progress, consistency, and technical adequacy. An overall LSA program status should be an integral part of these reviews whether conducted internally, with subcontractors, or with the

requiring authority. The results of performing activity's internal and subcontractor reviews should be documented and made available to the requiring authority on request.

50.1.4.3 In addition to system/equipment program and design reviews, specific reviews of the LSA program should be periodically conducted (Subtask 103.2.4). These reviews should provide a more detailed coverage of items addressed at program and design reviews and should address progress on all LSA tasks specified in the SOW. Representative discussion items include task results, data, status of assigned actions, design and supportability problems, test schedule and progress, and the status of subcontractors' and suppliers' efforts. LSA reviews should be conducted as part of ILS reviews when possible, and should be specified and scheduled in the SOW for Task 103. An integral part of this review process is the conduction of a detailed guidance conference as soon as possible after contract award to assure a thorough and consistent understanding of the LSA requirements between the requiring authority and performing activity. Additionally, the requiring authority must establish review policies which maximize the resources available for review. Sampling vs. 100 percent review of LSA data, scheduling reviews on an as required rather than a fixed schedule basis, and concentrating on drivers and high risk areas are some of the considerations that must be addressed in establishing the review policies.

50.1.4.4 In addition to formal reviews, useful information can often, be gained from performing activity data which is not submitted formally, but which can be made available through an accession list. A data item for this list must be included in the CDRL. This list is a compilation of documents and data which the requiring authority can order, or which can be reviewed at the performing activity's facility. Typically, the details of design analyses, test planning, test results, and technical decisions are included. These data constitute a source of information not otherwise available.

50.2 Task Section 200 - Mission and Support Systems Definition.

50.2.1 General Considerations. It is essential to conduct LSA early, in an acquisition program to identify constraints, thresholds, and targets for improvement, and to provide supportability input into early tradeoffs. It is during the early phases of an acquisition program that the greatest opportunity exists to influence design from a supportability standpoint. These analyses can identify supportability parameters for the new system/equipment which are reasonably attainable, along with the prime drivers of supportability, cost, and readiness. The drivers, once identified, provide a basis-for concentrated analysis effort to identify targets and methods of improvement. Mission and support systems definition tasks are generally conducted at system and sub system levels early in the system acquisition process (Concept, Demonstration and Validation Phases). Identification and analysis of risks play a key role due

MIL-STD-1388-1A
APPENDIX A

Procedures should be established between the requiring authority and performing activity to allow for specific evaluations and tradeoffs to be identified and conducted as required throughout the acquisition process. In selecting and conducting tradeoffs and evaluations for a given acquisition program, the following factors should be considered:

- a. System readiness analysis (Subtask 303.2.4) should always be considered a high priority.
- b. Select the tradeoff subtasks which deal with the supportability, cost, and readiness drivers of the system. Additionally, the scope of the selected tradeoff and evaluation subtasks can be limited to the drivers.
- c. Some tradeoffs and evaluations lend themselves to being performed by a specific community for input into the LSA program. For example, the diagnostic trade (Subtask 303.2.8) may best be performed under the Maintainability Program, the training trade (Subtask 303.2.6) may best be performed by training specialists, etc.
- d. Care should be exercised in using manhours as a criteria parameter for manpower trades (Subtask 303.2.5) because of two factors. First, each integral number of people has a range of manhours associated with it. Adding or reducing manhours has no effect on the number of people required until either the upper or lower limit of the range is breached. Then, and only then, does the number of people required change. Second, there is not a direct correlation between manhours and number of people required unless personnel skills are considered. For example, the same number of manhours may equate to one person required or many people required depending on the number of different skills required.
- e. Conceptual phase level of repair analysis (Subtask 303.2.7) should analyze gross concepts and define the depth of further analysis.
- f. Where applicable (e.g., in doing contractor versus organic support alternatives), assure that realistic personnel costs are used. Often Service published personnel costs do not include costs associated with recruitment, washouts, retention, etc., and use of these personnel costs may bias the tradeoff results.

50.4 Task Section 400 - Determination of Logistic Support Resource Requirements.

50.4.1 General Considerations. Logistic support resource requirements associated with proposed system/equipment alternatives must be identified and refined as the system/equipment progresses through its development. The extent of identification depends upon the magnitude and complexity of the new system/equipment and the phase of the acquisition cycle. As development progresses and the basic

design and operational characteristics are established, this determination becomes a process of analyzing specific design and operational data to more completely identify detailed logistic support resource requirements. This portion of the LSA defines the requirements of the principal elements of ILS. This analysis can be very costly and involve development of a considerable amount of documentation. In determining the timing and scope of analysis tasks in this section, the following should be considered:

- a. Early identification of logistic support resource requirements should be limited to new or critical requirements so that available resources are effectively used and sufficient acquisition time is allocated to the development and testing of these requirements. This identification should be accomplished as part of Task 303 (Subtask 303.2.2) and documentation should be limited to the minimum essential data.
- b. Resource requirements for different system alternatives should only be identified to the level required for evaluation and tradeoff of the alternatives.
- c. Logistic support resource requirements must be identified in a time frame which considers the schedule for developing the required documentation for each element of ILS. Schedule accomplishment of these tasks considering the time required to provision, develop technical manuals, establish training programs, etc.
- d. There are different levels of documentation that can be applied to the identification of logistic support resource requirements. (For example, supply support requirements can be identified through documentation of only a few data elements early in a program while later the total range of data elements required to accomplish initial provisioning can be documented.)
- e. Detailed input data for identification of logistic support resource requirements is generated by many system engineering functions. Therefore, analysis and documentation requirements and timing must be a coordinated effort between the LSA program and other system engineering programs to avoid duplication of effort and assure timely availability of required input data.

50.4.2 Task Analysis (Task 401). This task provides the detailed identification of requirements for all elements of ILS to operate and support the new system/equipment. It also includes an analysis of requirements to identify areas where supportability enhancements can be achieved. During performance of this task, the following will be determined for each operations and maintenance task:

MIL-STD-1388-1A
APPENDIX A

- a. Maintenance level, using the results of the LORA or similar analysis.
- b. Number of personnel, skill levels, skill specialties, manhours, and elapsed time.
- c. Spares, repair parts, and consumables required.
- d. Support equipment; test, measurement, and diagnostic equipment (TMDE); and test program sets (TPS) required.
- e. Training and training materiel required along with recommended training locations and rationale.
- f. Facilities required.
- g. Interval for and the frequency of task performance in the intended operational environment. The annual operating basis for task frequencies must be carefully selected and widely understood to prevent misuse of the information generated by this task.
- h. Packaging, handling, storage, and transportation requirements.

50.4.2.1 The timing and depth for performance of Task 401 is governed by the level of design and operation definition and by the program schedule. The analysis cannot be cost effectively performed until required input information from the design activity is available and cannot be delayed beyond a point that does not allow sufficient time to conduct the task analysis and use the results to develop ILS element documentation (e.g., technical manuals, personnel requirements list, etc.) in a timely manner. Demonstration and Validation Phase efforts should be limited to only essential information. During Full Scale Development (FSD), this task would be performed for all system/equipment components. During the Production and Deployment Phase, this task would be performed on any design changes.

50.4.2.2 The scope of this task can be effectively tailored to cost effectively meet program needs through identification of system hardware and software on which the analysis will be performed, identification of indenture level to which the analysis will be carried, identification of the maintenance levels that will be included in the analysis, and the identification of the amount of documentation required. This tailoring process must be done in conjunction with other system engineering programs and must consider the requirements of each ILS functional element.

50.4.2.3 Task analysis is probably the area of an LSA program which requires the most coordination and interfacing in that it involves essentially every system engineering discipline and ILS functional

element manager. When properly interfaced, task analysis provides a very cost effective means for assuring supportability of the system/equipment and developing an integrated support system for the system/equipment. When not properly interfaced, task analysis can be a very costly process which duplicates other analyses and generates incompatible ILS products. Design, reliability, maintainability, human engineering, safety, and others are all involved in satisfying the task analysis requirements of Task 401. The LSA program integrates and translates these inputs into output products required for preparation of ILS documents.

50.4.3 Early Fielding Analysis (Task 402). This task is designed to assure an effective fielding of the new system/equipment with all required resources. Subtask 402.2.1 is designed to quantify the effect on existing systems from the new system/equipment's deployment. This impact determination is necessary for the acquisition decision process to result in improved overall force capability and to assure planning to accommodate the new system/equipment effectively. Subtask 402.2.2 specifically addresses the manpower and personnel impact of the deployment. This subtask identifies where the necessary people and skills will come from for the new system/equipment, and what impact will be felt from this on other weapon systems. Subtask 402.2.3 identifies the effect on system readiness for varying levels of logistic support resources. This analysis forms the quantitative basis for budget requirements. Subtask 402.2.4 identifies logistic support resource requirements in alternative operational environments and provides the basis for wartime reserve stocks and mobilization plans and requirements. Subtask 402.2.5 requires plans to be developed to alleviate any potential fielding problems for the new system/equipment. These subtasks should only be selectively applied to equipment level acquisitions.

50.4.4 Post Production Support Analysis (Task 403). This task is intended to assure potential post production support problems are identified and addressed. Reprourement problems, closing of production lines, obsolescence of design, expected, discontinuances of business by manufacturers, etc., in the post deployment environment cause problems in assuring an adequate supply of spare and repair parts. If these factors are determined to present potential problems, plans must be established early to assure that effective life cycle support will be available for the new system/equipment.

50.5 Task Section 500 - Supportability Assessment.

50.5.1 General Considerations.

50.5.1.1 Types of Assessment. There are two general areas of supportability assessment covered in this section; assessment as part of the formal test and evaluation program, and assessment after deployment through analysis of operational, maintenance, and supply data on the system/equipment in its

TABLE III

Logistic Support Analysis Task Application and Documentation Matrix

TASK TITLE	APPLICABILITY BY PHASE *					APPLICABLE DATA ITEM DESCRIPTIONS	REMARKS
	PRE-CON-CEPT	CON-CEPT	DVAL	FSD	PROD		
202 MISSION HARDWARE, SOFTWARE, AND SUPPORT SYSTEM STANDARDIZATION	NA	G (2,4)	G (2,4)	G (2,4)	C (2,+)	DI-ILSS-81021 System/ Design Trade Study Report DI-MISC-80526 Parts Control Program Plan DI-MISC-80072A Program Parts Selection List (PPSL) DI-MISC-80071A Parts Approval Requests DI-E-7030 Test Data for Nonstandard Parts DI-ILSS-81286 Provisioning and Other Preprocurement data.	DI-MISC-80526 through DI-E-7030 pertain to the Parts Control Program. These DID's require citing MIL-STD-965 on the contract.
203 COMPARATIVE ANALYSIS	G	G	G	G	NA	DI-S-7116 Comparative Analysis Report	
Subtask 203.2.1	G	G	G	NA	NA		
Subtask 203.2.2	G(5)	G(5)	G(4)	G(4)	NA		
Subtask 203.2.3	G(5)	G(5)	G(4)	NA	NA		
Subtask 203.2.4	G(5)	G(5)	G(4)	G(4)	NA		

MIL-STD-1388-1A
APPENDIX A

TABLE III

Logistic Support Analysis Task Application and Documentation Matrix

TASK TITLE	APPLICABILITY BY PHASE *					APPLICABLE DATA ITEM DESCRIPTIONS	REMARKS
	PRE-CONCEPT	CONCEPT	DVAL	FSD	PROD		
203 COMPARATIVE ANALYSIS (cont.)							
Subtask 203.2.5	G(5)	G(5)	G(4)	G(4)	NA		
Subtask 203.2.6	G	G	G	NA	NA		
Subtask 203.2.7	NA	G(5)	G(4)	G(4)	NA		
Subtask 203.2.8	G	G	G	G	NA		
204 TECHNOLOGICAL OPPORTUNITIES	NA	G	G	S	NA	DI-S-7117 Technological Opportunities Report	
205 SUPPORTABILITY AND SUPPORTABILITY RELATED DESIGN FACTORS	NA	G	G	G	C	DI-ILSS-81021 System/Design Trade Study Reports	
Subtask 205.2.1	NA	G	G	NA	NA		See MIL-STD-1388-2 for LSAR data element definitions and applicable DIDs.
Subtask 205.2.2	NA	G	G	NA	NA		
Subtask 205.2.3	NA	G	G	G	G		
Subtask 205.2.4	NA	G(4)	G(4)	NA	NA		
Subtask 205.2.5	NA	NA	G	NA	NA		
Subtask 205.2.6	NA	G(4)	G(4)	NA	NA		
Subtask 205.2.7	NA	NA	G	NA	NA		

100 Supersedes page 100 of 5 June 1990

MIL-STD-1388-1A
APPENDIX A

TABLE III

Logistic Support Analysis Task Application and Documentation Matrix

TASK TITLE	APPLICABILITY BY PHASE *					APPLICABLE DATA ITEM DESCRIPTIONS	REMARKS
	PRE-CONCEPT	CONCEPT	DVAL	FSD	PROD		
301 FUNCTIONAL REQUIREMENTS IDENTIFICATION	NA	G	G	G	C	DI-ILSS 81021 System/ Design Trade Study Reports	Data requirements must be coordinated with Reliability, Maintainability, and Human Engineering Program requirements. See MIL-STD-1388-2 for LSAK data element definitions and applicable DIDs.
Subtask 301.2.1	NA	G	C	S(1)	C(1)		
Subtask 301.2.2	NA	G	C	S(1)	C(1)		
Subtask 301.2.3	NA	C	G	S(1)	C(1)		
Subtask 301.2.4	NA	S	G	G	C		
Subtask 301.2.5	NA	G	G	C	C		
Subtask 301.2.6	NA	G	G	G	C		
302 SUPPORT SYSTEM ALTERNATIVES	NA	G	G	G	C(1)	DI-ILSS-81021 System/ Design Trade Study Reports	
Subtask 302.2.1	NA	C(4)	G(4)	NA	NA		
Subtask 302.2.2	NA	G	G	S	NA		
Subtask 302.2.3	NA	S	S	G(4)	C(1,4)		
Subtask 302.2.4	NA	S	S	G	C(1)		
Subtask 302.2.5	NA	C	G	G	C(1)		
303 EVALUATION OF ALTERNATIVES AND TRADEOFF ANALYSIS	NA	G	G	G	C	DI-ILSS-81021 System/ Design Trade Study Reports	
Subtask 303.2.1	NA	G	G	G	C		
Subtask 303.2.2	NA	G	G	G	C		
Subtask 303.2.3	NA	G	G	G	C		
Subtask 303.2.4	NA	G	G	G	NA		
Subtask 303.2.5	NA	G	G	S	NA		

Supersedes page 101 of 5 June 1990 101

MIL-STD-1388-1A
APPENDIX A

TABLE III

Logistic Support Analysis Task Application and Documentation Matrix

TASK TITLE	APPLICABILITY BY PHASE *					APPLICABLE DATA ITEM DESCRIPTIONS	REMARKS
	PRE-CONCEPT	CONCEPT	DVAL	FSD	PROD		
303 EVALUATION OF ALTERNATIVE AND TRADEOFF ANALYSIS (cont.)							
Subtask 303.2.6	NA	G	G	G	C		
Subtask 303.2.7	NA	S(1)	G	G	C		
Subtask 303.2.8	NA	G	G	S(1)	NA		
Subtask 303.2.9	NA	G(5)	G(4)	S(1)	C(4)		
Subtask 303.2.10	NA	G(5)	G(4)	S	C(4)		
Subtask 303.2.11	NA	G(5)	G(4)	G(4)	C(4)		
Subtask 303.2.12	NA	G(5)	G(4)	NA	NA		
Subtask 303.2.13	NA	G(5)	G(4)	G	NA		
401 TASK ANALYSIS	NA	NA	S	G	C	DI-ILSS-81021 System/ Design Trade Study Reports	Subtasks 401.2.5, 401.2.6 and 401.2.9.
Subtask 401.2.1	NA	NA	S	G	C	DI-ILSS-81290 Contractors	
Subtask 401.2.2	NA	NA	S	G	C	Procurement Schedule for SAIP	Data requirements must be coordinated with ILS element data requirements.
Subtask 401.2.3	NA	NA	S	G(4)	C(4)	DI-ILSS-81285 Provisioning	See MIL-STD-1388-2 for
Subtask 401.2.4	NA	NA	S	G(4)	C(4)	Technical Documentation	LSAR data element
Subtask 401.2.5	NA	NA	S	G	C	DI-ILSS-81289 Engineering	definitions and
Subtask 401.2.6	NA	NA	S	G	C	Data for Provisioning	applicable DIDs.
Subtask 401.2.7	NA	NA	G(4)	S(1)	C(1)	DI-ILSS-81288 Statement of	
Subtask 401.2.8	NA	NA	S	G	C	Prior Submission	
Subtask 401.2.9	NA	NA	S	G	C	DI-ILSS-81287 Provisioning	
Subtask 401.2.10	NA	NA	S	G(4)	C(4)	Parts List Index	
Subtask 401.2.11	NA	NA	S	G	C	DI-ILSS-80293A Recommended	
Subtask 401.2.12	NA	NA	S	G	C	Spare Parts List for SAIP	
						DI-ILSS-81286 Provisioning	
						and other Preprocurement	
						Screening Data	

MIL-STD-1388-1A
APPENDIX A

102 Supersedes page 102 of 5 June 1990

TABLE III

Logistic Support Analysis Task Application and Documentation Matrix

TASK TITLE	APPLICABILITY BY PHASE *					APPLICABLE DATA ITEM DESCRIPTIONS	REMARKS
	PRE-CON-CEPT	CON-CEPT	DVAL	FSD	PROD		
402 EARLY FIELDING ANALYSIS	NA	NA	NA	G	C	DI-S-7118 Early Fielding Analysis Report	
403 POST PRODUCTION SUPPORT ANALYSIS	NA	NA	NA	NA	G	DI-P-7119 Post Production Support Plan	
501 SUPPORTABILITY TEST, EVALUATION, AND VERIFICATION	NA	G	G	G	G	DI-S-7120 Supportability Assessment Plan	Subtasks 501.2.1, 501.2.3, and 501.2.5.
Subtask 501.2.1	NA	G	G	S	NA	DI-S-7121 Supportability Assessment Report	Subtasks 501.2.4 and 501.2.6.
Subtask 501.2.2	NA	NA	G(4)	G(4)	G(4)	DI-ILSS-80532 System Support Package	Subtask 501.2.2.
Subtask 501.2.3	NA	NA	G(4)	G(4)	S	Component List	These data requirements must be coordinated with other system test planning and reporting requirements. See MIL-STD-1388-2 for LSAR data element definitions and applicable DIDs.
Subtask 501.2.4	NA	NA	G(4)	G(4)	S		
Subtask 501.2.5	NA	NA	NA	G(4)	S		
Subtask 501.2.6	NA	NA	NA	NA	G(4)		

NEW PAGE

102a

MIL-STD-1388-1A
APPENDIX A

Table III

Logistic Support Analysis Task Application
and Documentation Matrix - Continued.

*Program phases are characterized by the following design status:

1. PRE-CONCEPT - No design. Mission area analyses are performed on a continuing basis to include supportability and sustainability considerations within mission areas. Program requirements grow out of these analyses.
2. CONCEPT - Design is only conceptual. Best opportunity for identifying alternatives, conducting tradeoffs, and influencing design from a supportability standpoint.
3. DVAL - Performance characteristics are more or less established. Actual design is still flexible. Debugging and major changes in construction are taking place. Support alternatives and support, design, and operations alternatives are being traded. May result in a prototype.
4. FSD - Results in a prototype. Design is concentrating on construction, parts selection, and fine tuning of performance. No major design influence is possible. Design influence is limited to packaging, partitioning, testability, accessibility, etc. Support system is optimized.
5. PROD - Design is fixed. Logistic support resource planning is complete. No opportunity for tradeoffs or further optimization.

CODE DEFINITIONS:

- S - Selectively applicable.
- G - Generally applicable.
- C - Generally applicable to design changes only.
- NA - Not Applicable.
- (1) - Requires considerable interpretation of intent to be cost effective.
- (2) - MIL-STD-1388-1A is not the primary implementation document. Other MIL-STD's or statement of work requirements must be included to define the total requirements.
- (3) - Done just prior to initiation of the phase.
- (4) - Selectively applicable for equipment level acquisitions.
- (5) - Not applicable for equipment level acquisitions.

MIL-STD-1388-1A
APPENDIX B

GLOSSARY

10. SCOPE

10.1 Appendix B shall be considered as forming a part of the basic standard.

10.2 The purpose of this appendix is to provide definitions of terms used for clarity of understanding and completeness of information. As a general rule, the definitions provided are currently accepted and have been extracted verbatim from other directives (regulations, manuals, MIL-STD's, DOD Directives, etc.). A limited number of terms are presented for which definitions were developed from several reference documents.

20. DEFINITIONS

Actual manufacturer - An individual, activity, or organization that performs the physical fabrication process that produce the deliverable part or other items of supply for the Government. The actual manufacturer must produce the part in-house. The actual manufacturer may or may not be the design control activity.

Acquisition Phases

(a) Concept Exploration and Definition Phase - The identification and exploration of alternative solutions or solution concepts to satisfy a validated need.

(b) Demonstration and Validation Phase - The period when selected candidate solutions are refined through extensive study and analyses; hardware development, if appropriate; test; and evaluations.

(c) Full Scale Development Phase - The period when the system and the principal items necessary for its support are designed, fabricated, tested, and evaluated.

(d) Production and Deployment Phase - The period from production approval until the last system is delivered and accepted.

(e) Operations and Support - The Period following fielding of initial systems which is used to ensure systems continue to provide the capabilities required to meet the identified mission need.

Availability - A measure of the degree to which an item is in an operable and committable state at the start of a mission when the mission is called for at an unknown (random) time.

MIL-STD-1388-1A
APPENDIX B

Baseline Comparison System (BCS) - A current operational system, or a composite of current operational subsystems, which most closely represents the design, operational, and support characteristics of the new system under development.

Common and Bulk Items List (CBIL) - This list contains those items that are difficult or impractical to list on a topdown/disassembly sequence Provisioning Parts List (PPL), but for which provisioning is essential to support the operation of the end item/equipment. These items are subject to wear or failure, or otherwise required for maintenance, including planned maintenance, of the end item/equipment.

Comparability Analysis - An examination of two or more systems and their relationships to discover resemblances or differences.

Computer Resources Support - The facilities, hardware, software, and manpower needed to operate and support embedded computer systems. One of the principal elements of ILS.

Constraints - Restrictions or key boundary conditions that impact overall capability, priority, and resources in system acquisition.

Contract Data Requirements List (CDRL), DD Form 1423 Series. - A form used as the sole list of data and information which the contractor will be obligated to deliver under the contract, with the exception of that data specifically required by standard Defense Federal Acquisition Regulation (DFAR) clauses.

Contractor - Any individual, partnership, public or private corporation, association, institution, or other entity which enters into a specific contract with the government to provide supplies or services.

Contractors Procurement Schedule for SAIP - Schedule used to acquire information from contractors which will enable the Government to schedule spares procurement to coincide with the contractor's planned procurement for production.

Cost Estimating Relationship (CER) - A statistically derived equation which relates Life Cycle Cost or some portions thereof directly to parameters that describe the performance, operating, or logistics environment of a system.

Corrective Maintenance - All actions performed as a result of failure to restore an item to a specified condition. Corrective maintenance can include any or all of the following steps: Localization, Isolation, Disassembly, Interchange, Reassembly, Alignment, and Checkout.

Data Item Description (DID), DD Form 1664 - A form used to define and describe the data required to be furnished by the contractor. Completed forms are provided to contractors in support of and, for identification of, each data item listed on the CDRL.

Design Change Notice (DCN) - A formal document prepared by a contractor or a Government activity to

MIL-STD-1388-1A
APPENDIX B

notify the provisioning activity of changes to previously delivered provisioning lists which add to, delete, supersede or modify items which are approved for incorporation into the end item.

Design Parameters - Qualitative, quantitative, physical, and functional value characteristics that are inputs to the design process, for use in design tradeoffs, risk analyses, and development of a system that is responsive to system requirements.

End Item - A final combination of end products, component parts, and/or materials which is ready for its intended use; e.g., ship, tank, mobile machine shop, aircraft.

Engineering Data for Provisioning (EDFP) - Data acquired by contract to support Logistic Support Analysis Subtask 401.2.8. This data is necessary for the assignment of Source, Maintenance, and Recoverability (SMR) codes to each Provisioning List Item Sequence Number (PLISN) on the provisioning list. EDFP is also used for assignment of Item Management Codes, prevention of proliferation of identical items in the Government inventory, maintenance decisions, and item identification necessary in the assignment of a National Stock Number (NSN).

Facilities - The permanent or semi-permanent real property assets required to support the materiel system, including conducting studies to define types of facilities or facility improvements, locations, space needs, environmental requirements, and equipment. One of the principal elements of ILS.

Failure Modes, Effects, and Criticality Analysis (FMECA) - An analysis to identify potential design weaknesses through systematic, documented consideration of the following: all likely ways in which a component or equipment can fail; causes for each mode; and the effects of each failure (which may be different for each mission phase).

Fast Track Program - An acquisition program in which time constraints require the design, development, production, testing, and support acquisition process to be compressed or overlapped.

Follow-on Test and Evaluation (FOTE) - That test and evaluation which is conducted after the production decision to continue and refine the estimates made during previous operational test and evaluation, to evaluate changes, and to evaluate the system to insure that it continues to meet operational needs and retain its effectiveness in a new environment or against a new threat.

Functional Support Requirements (FSR) - A function (transport, repair, resupply, recover, calibrate, overhaul, etc.) that the support system must perform for the end item to be maintained in or restored to a satisfactory operational condition in its operational environment.

Goals - Values, or a range of values, apportioned to the various design, operational, and support elements of a system which are established to optimize the system requirements.

MIL-STD-1388-1A
APPENDIX B

Government Furnished Material (GFM) - Material provided by the Government to a contractor or comparable Government production facility to be incorporated in, attached to, used with or in support of an end item to be delivered to the Government or ordering activity, or which may be consumed or expended in the performance of a contract. It includes, but is not limited to, raw and processed materials, parts, components, assemblies, tools and supplies. Material categorized as Government Furnished Equipment (GFE) and Government Furnished Aeronautical Equipment (GFAE) are included.

General Conference - A conference that may be held at any time during the life of the contract for the purpose of resolving provisioning problems.

Guidance Conference - A conference used to ensure that the contractor and the Government have a firm understanding of the contractual provisioning requirements, establish funding and task milestones, and formulate firm commitments for optional requirements in accordance with applicable data requirements.

Integrated Logistic Support (ILS) - A disciplined approach to the activities necessary to: (a) cause support considerations to be integrated into system and equipment design, (b) develop support requirements that are consistently related to design and to each other, (c) acquire the required support; and (d) provide the required support during the operational phase at minimum cost.

Interim Release - Authorization given a contractor to release support items to production or procurement prior to receipt of a provisioned item order (PIO).

Interim Support Items Conference (ISIC) - A conference for the Government to review, select and approve those items recommended for interim support (i.e. contractor supply/logistics support) by the contractor as cost effective for advance procurement prior to the time provisioning for operational requirements has been accomplished and a provisioned item order (PIO) has been provided.

Interim Support Items List (ISIL) - This list contains those support items required between operational need date and the point in time that provisioning for operational requirements has been accomplished.

Logistic Support Analysis (LSA) - The selective application of scientific and engineering efforts undertaken during the acquisition process, as part of the system engineering and design process, to assist in complying with supportability and other ILS objectives.

Logistic Support Analysis Documentation - All data resulting from performance of LSA tasks conducted under this standard pertaining to an acquisition program.

LSA Guidance Conference - A conference used to ensure that the contractor and the government have a firm understanding of the relationship of the LSA tasks to the LSA documentation, task milestones, and funding levels contractually required. The provisioning guidance conference may be held in conjunction with or as part of the LSA guidance conference if the provisioning activity agrees.

MIL-STD-1388-1A
APPENDIX B

Logistic Support Analysis Record (LSAR) - That portion of LSA documentation consisting of detailed data pertaining to the identification of logistic support resource requirements of a system/equipment. See MIL-STD-1388-2 for LSAR data element definitions.

Long Lead Time Items (LLTI) - Those items which because of their complexity of design, complicated manufacturing process, or limited production capacity, cause extended production or procurement cycle which would preclude delivery in time to meet operational need date if not ordered in advance of normal provisioning.

Long Lead Time Items Provisioning Conference (LLTILC) - A conference for the Government personnel to review and select the long lead time items required for support of the end item. Interim Release Items may be reviewed during this conference.

Long Lead Time Items List (LLTIL) - A LLTIL contains those items which, because of their complexity of design, complicated manufacturing process or limited production capacity, may cause production or procurement cycles which would preclude timely and adequate delivery, if not ordered in advance of normal provisioning.

Maintainability - The measure of the ability of an item to be retained in or restored to a specified condition when maintenance is performed by personnel having specified skill levels, using prescribed procedures and resources, at each prescribed level of maintenance and repair.

Maintenance Levels - The basic levels of maintenance into which all maintenance activity is divided. The scope of maintenance performed within each level must be commensurate with the personnel, equipment, technical data, and facilities provided.

Maintenance Planning - The process conducted to evolve and establish maintenance concepts and requirements for a materiel system. One of the principal elements of ILS.

Manpower - The total demand, expressed in terms of the number of individuals, associated with a system. Manpower is indexed by manpower requirements, which consist of quantified lists of jobs, slots, or billets that are characterized by the descriptions of the required number of individuals who fill the jobs, slots, or billets.

Manpower and Personnel - The identification and acquisition of military and civilian personnel with the skills and the grade required to operate and support a materiel system at peacetime and wartime rates. One of the principal elements of ILS.

Objectives - Qualitative and quantitative values, or range of values, apportioned to the various design,

MIL-STD-1388-1A
APPENDIX B

operational, and support elements of a system which represent the desirable levels of performance. Objectives are subject to tradeoffs to optimize system requirements.

Operating and Support (O&S) Costs - The cost of operation, maintenance, and follow-on logistics support of the end item and its associated support systems. This term and "ownership cost" are synonymous.

Operational Concept - A statement about intended employment of forces that provides guidance for posturing and supporting combat forces. Standards are specified for deployment, organization, basing, and support from which detailed resource requirements and implementing programs can be derived.

Operational Scenario - An outline projecting a course of action under representative operational conditions for an operational system.

Operational Suitability - The degree to which a system can be satisfactorily placed in field use, with consideration being given availability, compatibility, transportability, interoperability, reliability, wartime usage rates, maintainability, safety, human factors, manpower supportability, logistics supportability, and training requirements.

Optimization Models - Models which accurately describe a given system and which can be used, through sensitivity analysis, to determine the best operation of the system being modeled.

Packaging, Handling, Storage, and Transportation - The resources, processes, procedures, design considerations and methods to ensure that all system, equipment, and support items are preserved, packaged, handled, and transported properly including: environmental considerations and equipment preservation requirements for short and long term storage, and transportability. One of the principal elements of ILS.

Parametric Estimating Relationship (PER) - Statistical parametric analysis essentially involves development and application of mathematical expressions commonly called "cost estimating relationships" (CER's). Basically, CER's are developed by statistically analyzing past history to correlate cost with significant physical and functional parameters.

Performing Activity - That activity (government, contractor, subcontractor, or vendor) which is responsible for performance of LSA tasks or subtasks as specified in a contract or other formal document of agreement.

Personnel - The supply of individuals, identified by specialty or classification, skill, skill level, and rate or rank, required to satisfy the manpower demand associated with a system. This supply includes both those individuals who support the system directly (i.e., operate and maintain the system), and those individuals who support the system indirectly by performing those functions necessary to produce and maintain the personnel required to support the system directly. Indirect support functions include recruitment, training, retention, and development,

MIL-STD-1388-1A
APPENDIX B

Post Conference List (PCL) - This list contains those items selected for the operations, maintenance and support of the system/end article as a result of the Provisioning Conference review.

Preventive Maintenance - All actions performed in an attempt to retain an item in specified condition by providing systematic inspection, detection, and prevention of incipient failures.

Procuring Activity - The activity which awards contracts for deliverable hardware, software, firmware, courseware and/or data.

Provisioned Item Order (PIO) - A formal requirements document furnished to the contract administration activity to identify items to be bought through the provisioning process on a contract, providing the specific items to be ordered, the estimated cost, and the required delivery schedule and destination. The PIO is provided with other formal contract documentation to the contractor to place items on order. The PIO is an unpriced order.

Provisioning - The process of determining and acquiring the range and quantity (depth) of spares and repair parts, and support and test equipment required to operate and maintain an end item of materiel for an initial period of service.

Provisioning Activity (PA) - That organization of a using Military Service, or that organization delegated by a using Service, which is responsible for the selection of and the determination of requirements for provisioning items.

Provisioning Conference - A conference for reviewing PTD/EDFP, and for Government validation of support items and the assignment of technical and management codes made during the Logistics Support Analysis (LSA) process when specified by the provisioning activity. LSA is the analytical source from which provisioning decisions are made.

Provisioning methods - Method by which the Provisioning Activity (PA) will make provisioning decisions. The method will be specified in the provisioning, requirements. The following provisioning methods are applicable:

(a) Resident Provisioning Team (RPT) method - This method employs a Government team permanently assigned at the contractor's facility skilled in the functions of provisioning control, source, maintenance, and recoverability coding, requirements determination, cataloging, etc.

(b) Conference team method - This method employs Government representatives at the contractor's or vendor's facility. The conference team is not permanently assigned to the contractor's facility.

(c) In house method - The Government conducts provisioning at the PA or at the provisioning activity or other location specified by the prime provisioning activity. Contractor participation will be specified by the PA.

MIL-STD-1388-1A
APPENDIX B

(d) Logistic Support Analysis Record (LSAR) method - Functions of provisioning are conducted solely during the periodic LSA reviews, to include the guidance and provisioning conference.

Provisioning Parts List (PPL) - This list structured at the end item, component, or assembly level as specified by the PA, contains the end item, component, or assembly equipment and all support items which can be disassembled, reassembled, or replaced, and which, when combined, constitute the end item, component, or assembly equipment.

Provisioning Parts List Index (PPLI) - The PPLI is a listing by manufacturer's reference numbers of all items listed in the Provisioning Parts List (PPL) cross-referenced to each item's Provisioning List Item Sequence Number (PLISN).

Provisioning Preparedness Review Conference - This conference is held for the Government to determine the adequacy of the provisioning documentation, facilities, and the overall preparations made by the contractor to conduct a provisioning conference.

Provisioning Technical Documentation (PTD) - PTD as used in this standard, is the generic term used to reference the various types of Provisioning Lists, This term is used by the DoD components for the identification, selection, and determination of initial requirements and cataloging of support items to be procured through the provisioning process. Applicable PTD is as follows:

- (a) Provisioning Parts List (PPL)
- (b) Short Form Provisioning Parts List (SFPPL)
- (c) Long Lead Time Items List (LLTIL)
- (d) Repairable Items List (RIL)
- (e) Interim Support Items List (ISIL)
- (f) Tools and Test Equipment List (TTEL)
- (g) Common and Bulk Items List (CBIL)
- (h) Design Change Notices (DCN)
- (i) Post Conference List (PCL)
- (j) System Configuration Provisioning List (SCPL)

Readiness Drivers - Those system characteristics which have the largest effect on a system's readiness values. These may be design (hardware or software), support, or operational characteristics.

Reliability - (1) The duration or probability of failure-free performance under stated conditions. (2) The probability that an item can perform its intended function for a specified interval under stated conditions. (For nonredundant items this is equivalent to definition (1). For redundant items this is equivalent to mission reliability.)

Reliability and Maintainability Interface - Reliability and maintainability design parameters are a key factor in the design of affordable and supportable systems. R&M parameters provide inputs into the design and LSA process that quantitatively link system readiness to the ILS elements. One of the principal elements of ILS.

MIL-STD-1388-1A
APPENDIX B

Reliability Centered Maintenance - A systematic approach for identifying preventive maintenance tasks for an equipment end item in accordance with a specified set of procedures and for establishing intervals between maintenance tasks.

Repair Parts - Those support items that are an integral part of the end item or system which are coded as nonrepairable.

Repairable Items List (RIL) - This list contains all support items of a repairable nature and used in or associated with the end item.

Requiring Authority - That activity (government, contractor, or subcontractor) which levies LSA task or subtask performance requirements on another activity (performing activity) through a contract or other document of agreement.

Risks - The opposite of confidence or assurance; the probability that the conclusion reached as to the contents of a lot (number of defects or defective range) is incorrect.

Scheduled Maintenance - Preventive maintenance performed at prescribed points in the item's life.

Sensitivity Analysis - An analysis concerned with determining the amount by which model parameter estimates can be in error before the generated decision alternative will no longer be superior to others.

Short Form Provisioning Parts List (SFPPL) - This list contains only those support items which are recommended by the contractor for maintenance of the end item, i.e. only those items recommended by the contractor as procurable spares.

Site Survey - An examination of potential locations and supporting technical facilities for capability to base a system.

Source, Maintenance and Recoverability (SMR) Codes - Uniform codes assigned to all support items early in the acquisition cycle to convey maintenance and supply instructions to the various logistic support levels and using commands. They are assigned based on the logistic support planned for the end item and its components. The uniform code format is composed of three, two character parts: Source Codes, Maintenance Codes, and Recoverability Codes in that order.

Spares - Those support items that are an integral part of the end item or system which are coded as repairable.

Spares Acquisition Integrated with Production (SAIP) - A procedure used to combine procurement of selected spares with procurement of identical items produced for installation on the primary system, subsystem, or equipment.

MIL-STD-1388-1A
APPENDIX B

Special (tools, test equipment, support equipment) - Tools, test equipment, and support equipment that have single or peculiar application to a specific end item.

Standardization and Interoperability.

Standardization. The process by which member nations achieve the closest practicable cooperation among forces; the most efficient use of research, development, and production resources; and agree to adopt on the broadest possible basis the use of: (1) common or compatible operational, administrative, and logistics procedures; (2) common or compatible technical procedures and criteria; (3) common, compatible, or interchangeable supplies, components, weapons, or equipment; and (4) common or compatible tactical doctrine with corresponding organizational compatibility.

Interoperability. The ability of systems, units, or forces to provide services to and accept services from other systems, units, or forces and to use the services so exchanged to enable them to operate effectively together.

Statement of Prior Submission (SPS) - The SPS certifies that the contractor/subcontractor has previously furnished the Government PTD which satisfies the PTD requirements of the solicitation or the provisioning requirements submitted after award of the contract. The SPS applies to the end item or to any component thereof.

Subcontractor - A contracting entity that furnishes supplies or service to or for a prime contractor or another subcontractor.

Supply Support - All management actions, procedures, and techniques required to determine requirements for, acquire, catalog, receive, store, transfer, issue, and dispose of secondary items. This includes provisioning for initial support as well as replenishment supply support. One of the principal elements of ILS.

Supportability - A measure of the degree to which all resources required to operate and maintain the system/equipment can be provided in sufficient quantity. Supportability encompasses all elements of ILS, as defined in DoDI 5000.2.

Supportability Assessment - An evaluation of how well the composite of support considerations necessary to achieve the effective and economical support of a system for its life cycle meets stated quantitative and qualitative requirements. This includes integrated logistic support and logistic support resource related O&S cost considerations.

Supportability Factors - Qualitative and quantitative indicators of supportability.

Supportability Related Design Factors - Those supportability factors which include only the effects of an item's design. Examples include inherent reliability and maintainability values, testability values,

MIL-STD-1388-1A
APPENDIX B

transportability characteristics, etc.

Support Concept - A complete system level description of a support system, consisting of an integrated set of ILS element concepts, which meets the functional support requirements and is in harmony with the design and operational concepts.

Support Equipment - All equipment (mobile or fixed) required to support the operation and maintenance of a materiel system. This includes associated multi-user end items, ground handling and maintenance equipment, tools, metrology and calibration equipment, communications resources, test equipment and automatic test equipment, with diagnostic software for both on and off equipment maintenance. It includes the acquisition of logistics support for the support and test equipment itself. One of the principal elements of ILS.

Support Items - Items subordinate to, or associated with, an end item (i.e., spares, repair parts, tools, test equipment, and sundry materials) and required to operate, service, repair or overhaul an end item.

Support Plan - A detailed description of a support system covering each element of ILS and having consistency between the elements of ILS. Support plans cover lower hardware indenture levels and provide a more detailed coverage of maintenance level functions than support concepts.

Support Resources - The materiel and personnel elements required to operate and maintain a system to meet readiness and sustainability requirements. New support resources are those which require development. Critical support resources are those which are not new but require special management attention due to schedule requirements, cost implications, known scarcities, or foreign markets.

Support System - A composite of all the resources that must be acquired for operating and maintaining a system or equipment throughout its life cycle.

System Configuration Provisioning List (SCPL) - This list establishes the family tree relationship of components to end item when associated PLs are developed at a component level. It also includes components which will be government furnished and separately provisioned.

System Effectiveness - A measure of an items ability to meet operational requirements as a function of performance of the hardware, operator/maintainer and environment (operational, social, physical). System effectiveness takes into account man/machine and man/man interfaces.

System Engineering Process - A logical sequence of activities and decisions transforming an operational need into a description of system performance parameters and a preferred system configuration.

System/Equipment - The item under analysis, be it a complete system, or any portion thereof being procured.

MIL-STD-1388-1A
APPENDIX B

System Readiness - A measure or measures of the ability of a system to undertake and sustain a specified set of missions at planned peacetime and wartime utilization rates. System readiness measures take explicit account of the system design (reliability and maintainability), the characteristics and performance of the support system, and the quantity and location of support resources. Examples of typical readiness measures are sortie rate mission capable rate, operational availability, and asset ready rate.

Tailoring - The process by which the individual requirements (sections, paragraphs, or sentences) of the selected specifications and standards are evaluated to determine the extent to which each requirement is most suitable for a specific materiel acquisition and the modification of these requirements, where necessary, to assure that each tailored document invoked states only the minimum needs of the Government. Tailoring is not a license to specify a zero LSA program, and must conform to provisions of existing regulations governing LSA programs.

Task - A single unit of specific work behavior with clear beginning and ending points and directly observable or otherwise measurable process, frequently, but not always resulting in a product that can be evaluated for quantity, quality, accuracy, or fitness in the work environment. A task is the lowest level of behavior in a job that describes the performance of a meaningful function in the job under consideration.

Task Analysis - A process of reviewing job content and context as it pertains to an emerging equipment design to classify units of work (duties/primary skills and tasks/discrete skills) within a job. The process provides a procedure for isolating each unique unit of work and for describing each unit accomplished.

Task Inventory - A comprehensive listing of all tasks performed by system personnel to operate and maintain the item.

Task Taxonomy - The following taxonomy will be utilized to inventory and analyze tasks:

- (a) **Mission:** What the system is supposed to accomplish, e.g., combat reconnaissance.
- (b) **Scenario/Conditions:** Categories of factors or constraints under which the system will be expected to operate and be maintained, e.g., day/night, all weather, all terrain operation.
- (c) **Functions:** A broad category of activity performed by a system, e.g., transportation.
- (d) **Job:** The combination of all human performance required for operation and maintenance of one personnel position in a system, e.g., driver.
- (e) **Duty:** A set of operationally-related tasks within a given job, e.g., driving, weapon servicing, communicating, target detection, self protection, operator maintenance.

MIL-STD-1388-1A
APPENDIX B

(f) Task: A composite of related activities (perceptions, decisions, and responses) performed for an immediate purpose, written in operator/maintainer language, e.g., change a tire.

(g) Subtask: Activities (perceptions, decisions, and responses) which fulfill a portion of the immediate purpose within a task, e.g., remove lug nuts.

(h) Task Element: The smallest logically and reasonably definable unit of behavior required in completing a task or subtask, e.g., apply counter clockwise torque to the lug nuts with a lug wrench.

Technical Data - Recorded information regardless of form or character (e.g. manuals, drawings) of a scientific or technical nature. Computer programs and related software are not technical data; documentation of computer programs and related software are. Also excluded are financial data or other information related to contract administration. One of the principal elements of ILS.

Testability - A design characteristic which allows the status (operable, inoperable, or degraded) of an item and the location of any faults within the item to be confidently determined in a timely fashion.

Thresholds - Values, or a range of values, apportioned to the various design, operational, and support elements of a system which impose a quantitative or qualitative minimum - essential level of performance. Thresholds are usually associated with a goal.

Tools and Test Equipment - Those support items that are not an integral part of the end item but are required to inspect, test, calibrate, service, repair, or overhaul an end item. Tools and test equipment are a subset of support equipment.

Tools and Test Equipment List (TTEL) - A listing of support equipment required to inspect, test, calibrate, service, repair, or overhaul an end item.

Tradeoff - The determination of the optimum balance between system characteristics (cost, schedule, performance, and supportability).

Training - The structured process by which individuals are provided with the skills necessary for successful performance in their job, slot, billet, or specialty.

Training and Training Devices - The processes, procedures, techniques, and equipment used to train active and reserve personnel to operate and support a materiel system. This includes individual and crew training, new equipment training, and logistic support for the training devices themselves. One of the principal elements of ILS.

MIL-STD-1388-1A
APPENDIX B

Transportability - The inherent capability of material to be moved with available and projected transportation assets to meet schedules established in mobility plans, and the impact of system equipment and support items on the strategic mobility of operating military forces.

Unscheduled Maintenance - Corrective maintenance required by item conditions.