

INCH-POUND

MIL-DTL-5015H  
18 May 2000  
SUPERSEDING  
MIL-C-5015G  
AMENDMENT 5  
15 March 1994

## DETAIL SPECIFICATION

### CONNECTORS, ELECTRICAL, CIRCULAR THREADED, AN TYPE, GENERAL SPECIFICATION FOR

This specification is approved for use by all Departments and Agencies of the Department of Defense.

#### 1. SCOPE

1.1 Scope. This specification covers circular threaded electrical connectors with solder or removable crimp contacts (both front and rear release). These connectors are for use in electronic, electrical power, and control circuits (see 6.1).

1.2 Classification. Electrical connectors covered by this specification are divided into the following classes, series, and receptacle styles.

1.2.1 Classes. The classes of electrical connectors are as follows:

- Class A - Solid shell solder contact connectors
- Class B - Split shell solder contact connectors
- Class C - Solder contact connectors for use with pressurized equipment
- Class D - Crimp and solder contact connectors for use in high-impact shock conditions
- Class DJ - Crimp contact connectors with backshell connector assembly for use in high impact shock conditions

Beneficial comments (recommendations, additions, deletions) and any pertinent data which may be of use in improving this document should be addressed to: Commander, Naval Air Warfare Center Aircraft Division, Systems Standardization Division, Code 414100B120-3, Highway 547, Lakehurst, NJ 08733-5100, by using the Standardization Document Improvement Proposal (DD Form 1426) appearing at the end of this document or by letter.

AMSC N/A

FSC 5935

DISTRIBUTION STATEMENT A. Approved for public release; distribution is unlimited.

## MIL-DTL-5015H

- Class E - Environment resistant solder contact connectors
- Class F - Environment resistant solder contact connectors, with clamp
- Class H - Hermetic solder contact connectors
- Class K - Crimp and solder firewall connectors
- Class L - Fluid resistant crimp contact connectors
- Class P - Environment resistant potted solder contact connectors
- Class R - Crimp and solder contact connector with grommet seal without clamp
- Class U - Fluid resistant crimp contact connectors
- Class W - General purpose crimp contact connectors

1.2.2 Series. The series of electrical connectors are as follows:

- Series I - Solder contact connectors
- Series II - Front release, crimp contact connectors
- Series III - Rear release, crimp contact connectors
- Series IV - Connector accessories

1.2.3 Receptacle styles. The receptacle styles of electrical connectors are as follows:

- Flange (box or wall)
- Jam nut
- Cable connecting
- Solder mounting

## 2. APPLICABLE DOCUMENTS

2.1 General. The documents listed in this section are specified in sections 3 and 4 of this specification. This section does not include documents cited in other sections of this specification or recommended for additional information or as examples. While every effort has been made to ensure the completeness of this list, document users are cautioned that they must meet all specified requirements documents cited in sections 3 and 4 of this specification, whether or not they are listed.

2.2 Government documents.

2.2.1 Specifications and standards. The following specifications and standards form a part of this document to the extent specified herein. Unless otherwise specified, the issues of these documents are those listed in the issue of the Department of Defense Index of Specifications and Standards (DoDISS) and supplement thereto, cited in the solicitation (see 6.2).

## MIL-DTL-5015H

### SPECIFICATIONS

#### FEDERAL

- L-P-410 - Plastic, Polyamide (Nylon), Rigid, Rods, Tubes, Flats, Molded and Cast Parts.
- QQ-S-365 - Silver Plating, Electrodeposited, General Requirements for.
- QQ-P-416 - Plating, Cadmium (Electrodeposited).

#### DEPARTMENT OF DEFENSE

- MIL-S-901 - Shock Tests H.I. (High-Impact) Shipboard Machinery, Equipment, and Systems, Requirements for.
- MIL-C-915 - Cable and Cord, Electrical, for Shipboard Use, General Specification for.
- MIL-H-5606 - Hydraulic Fluid, Petroleum Base; Aircraft, Missile, and Ordnance. (Inactive for new design)
- MIL-S-7742 - Screw Threads, Standard, Optimum Selected Series: General Specification for. (Inactive for new design)
- MIL-PRF-7808 - Lubricating Oil, Aircraft Turbine Engine, Synthetic Base.
- MIL-PRF-8516 - Sealing Compound, Synthetic Rubber, Electric Connectors and Electric Systems, Chemically Cured.
- MIL-W-16878 - Wire, Electrical, Insulated, General Specification for.
- MIL-DTL-22520 - Crimping Tools, Terminal, General Specification for.
- MIL-W-22759 - Wire, Electrical, Fluoropolymer-Insulated, Copper or Copper Alloy.
- MIL-PRF-23586 - Sealing Compound (With Accelerator), Silicone Rubber, Electrical.
- MIL-W-25038 - Wire, Electrical, High Temperature, Fire Resistant, and Flight Critical, General Specification for.
- MIL-C-39029 - Contacts, Electrical Connector, General Specification for.
- MIL-C-39029/29 - Contacts, Electrical Connector, Pin, Crimp Removable, (For MIL-C-5015 Series MS3450 and MIL-C-83723 Series II Connectors).
- MIL-C-39029/30 - Contacts, Electrical Connector, Socket, Crimp Removable, (For MIL-C-5015 MS3450 Series and MIL-C-83723 Series II Connectors).
- MIL-C-39029/44 - Contact, Electrical Connector, Pin, Crimp Removable (For MIL-C-5015 Series MS3400 Connectors).
- MIL-C-39029/45 - Contacts, Electrical Connector, Socket, Crimp Removable, (For MIL-C-5015 Series MS3400 Connectors).
- MIL-DTL-81381 - Wire, Electric, Polyamide-Insulated, Copper or Copper Alloy.

## MIL-DTL-5015H

- MIL-I-81969/14 - Installing and Removal Tools, Connector, Electrical Contact, Type III, Class 2, Composition B.
- MIL-I-81969/15 - Installing and Removal Tools, Connector, Electrical Contact, Type II, Class 2, Composition A.
- MIL-I-81969/17 - Installing and Removal Tools, Connectors, Electrical Contact, Type I, Class 1, Composition C.
- MIL-I-81969/19 - Installing and Removal Tools, Connector, Electrical Contact, Type II, Class 1, Composition C.
- MIL-C-85049 - Connector Accessories, Electrical, General Specification for.
- MIL-C-85049/11 - Connector Accessories, Electrical, Backshell, Environmental, Cable Sealing, Straight Category 1A (For MIL-C-5015 Crimp, MIL-C-26482 Series 2, MIL-C-81703 Series 3, and MIL-C-83723 Series III Connectors).
- MIL-C-85049/52 - Connector Accessories, Electrical, Strain Relief, Self-Locking and Non-Self-Locking, Straight, Category 4B (For MIL-C-5015 Crimp, MIL-C-26482 Series 2, MIL-C-81703 Series 3, and MIL-C-83723 Series III Connectors).

(See supplement 1 for list of MS sheets.)

## STANDARDS

### FEDERAL

- FED-STD-H28 - Screw-Thread Standards for Federal Services.

### DEPARTMENT OF DEFENSE

- MIL-STD-167-1 - Mechanical Vibrations of Shipboard Equipment (Type I-Environmental and Type II-Internally Excited).
- MIL-STD-1285 - Marking of Electrical and Electronic Parts.
- MIL-STD-1344 - Test Methods for Electrical Connectors.
- MIL-STD-1651 - Insert Arrangements for MIL-C-5015, MIL-C-22992 (Classes C, J, and R), and MIL-C-83723 (Series II) Electrical Connectors.

(Unless otherwise indicated, copies of the above specifications and standards are available from the Standardization Document Order Desk, 700 Robbins Avenue, Building 4D, Philadelphia, PA 19111-5094.)

2.3 Non-Government publications. The following documents form a part of this document to the extent specified herein. Unless otherwise specified, the issues of the documents

## MIL-DTL-5015H

which are DoD adopted are those listed in the issue of the DoDISS cited in the solicitation. Unless otherwise specified, the issues of the documents not listed in the DoDISS are the issues of the documents cited in the solicitation (see 6.2).

### AMERICAN NATIONAL STANDARDS INSTITUTE

- ANSI-Z540.1 - Laboratories, Calibration, and Measuring and Test Equipment. (DoD adopted)

(Application for copies should be addressed to American National Standards Institute, 11 West 42nd Street, New York, NY 10036.)

### AMERICAN SOCIETY FOR TESTING AND MATERIALS (ASTM)

- ASTM-B85 - Aluminum-Alloy Die Castings. (DoD adopted)
- ASTM-A342 - Materials, Feebly Magnetic, Permeability of. (DoD adopted)
- ASTM-B488 - Gold for Engineering Uses, Electrodeposited Coatings of. (DoD adopted)
- ASTM-A582 - Free-Machining Stainless and Heat Resisting Steel Bars. (DoD adopted)
- ASTM-B733 - Metals, Autocatalytic Electroless Nickel-Phosphorus Coating On. (DoD adopted)

(Application for copies should be addressed to the American Society for Testing and Materials, 100 Barr Harbor Drive, West Conshohocken, PA 19428-2959.)

### THE INSTITUTE FOR INTERCONNECTING AND PACKING ELECTRONIC CIRCUITS

- J-STD-001 - Requirements for Soldered Electrical and Electronic Assemblies.
- J-STD-006 - Electronic Grade Solder Alloys and Fluxed and Non-Fluxed Solid Solders for Electronic Soldering Applications Requirements For.

(Application for copies should be addressed to the Institute for Interconnecting and Packaging Electronic Circuits (IPC, Inc), 2215 Sanders Road, Suite 200 South, Northbrook, IL 60062-6126.)

## MIL-DTL-5015H

### SOCIETY OF AUTOMOTIVE ENGINEERS (SAE)

- SAE-AIR1351 - Aerospace Electrical and Electronic Wiring Devices and Accessories, Manufacturers' Identification of. (DoD adopted)
- SAE-AMS-QQ-S-763 - Steel Bars, Wire, Shapes, and Forgings; Corrosion Resistant. (DoD adopted)
- SAE-AS31091 - Boots, Heat-Shrinkable, Strain-Relief Straight. (DoD adopted)
- SAE-AS31971 - Pin, Gage for Socket Contact Engagement Test. (DoD adopted)
- SAE-AS34021 - Connector, Receptacle, Electric, Box Mounting, Front Release, Crimp Contact, AN Type with. (DoD adopted)
- SAE-AS34121 - Connectors, Receptacle, Electric, Wall Mounting, Front Release, Crimp Contact, AN Type-with Accessory Threads. (DoD adopted)
- SAE-AS34591 - Connectors, Plug, Electrical, Self-Locking, Coupling Nut, Rear Release, Crimp Contact, AN Type. (DoD adopted)

(Applications for copies should be addressed to Society of Automotive Engineers, Inc., 400 Commonwealth Drive, Warrendale, PA 15096.)

2.4 Order of precedence. In the event of a conflict between the text of this document and the references cited herein (except for related associated specifications, or MS sheets), the text of this document shall take precedence. Nothing in this document, however, supersedes applicable laws and regulations unless a specific exemption has been obtained.

### 3. REQUIREMENTS

3.1 MS sheets. The individual item requirements shall be as specified herein and in accordance with the applicable MS sheets. In the event of any conflict between the requirements of this specification and the MS sheets, the latter shall govern.

3.2 Qualification. The connectors furnished under this specification shall be products that are authorized by the qualifying activity for listing on the applicable qualified products list before contract award (see 4.3 and 6.14).

#### 3.3 Materials.

3.3.1 Dissimilar metals. When dissimilar metals are employed in contact with each other in a connector or in a mated pair of connectors, protection against galvanic corrosion shall be provided (see 6.17).

## MIL-DTL-5015H

3.3.2 Nonmagnetic materials (except class H and K connectors). All parts shall be made of materials which are classed as nonmagnetic except for classes H and K connectors (see 1.2 and 3.6).

### 3.3.3 Contacts.

3.3.3.1 Contact materials. Contacts shall be made of conductive materials. Thermocouple contacts shall be made of a material compatible with the thermocouple wire to which attachment is intended (see 6.16).

### 3.3.3.2 Contact plating.

3.3.3.2.1 Contact plating (solder type, except class H). Contacts shall be silver plated in accordance with QQ-S-365 or gold plated in accordance with ASTM-B488 over silver plating in accordance with QQ-S-365. The resultant minimum thickness of contact plating shall be 100 microinches. Accessory members of the socket contacts need not be plated but shall meet the requirements for dissimilar metals specified in 3.3.1.

3.3.3.2.2 Contact plating (class H connectors). Contacts shall be gold plated to a thickness of not less than 50 microinches in accordance with ASTM-B488, type 3, code C, over an underplate approved by the qualifying activity (see 6.14). A silver underplate shall not be used.

3.3.3.2.3 Contact plating (thermocouple). Thermocouple contacts shall be cadmium plated in accordance with QQ-P-416, or otherwise protected from corrosion. Accessory members of the socket contacts need not be plated, but shall meet the requirements for dissimilar metals (see 3.3.1).

### 3.3.4 Dielectric materials.

3.3.4.1 Insert and grommet. Insert and grommet materials shall be dielectric having hardness, electrical, and mechanical characteristics capable of meeting the requirements of this specification.

3.3.4.1.1 Connectors (except solder contact class A, B, C, H, K, and P). The mating faces of pin inserts of solder contact connectors shall be a resilient material within a Shore A Durometer range of 60 to 85. On crimp contact front release connectors and rear release style P connectors the Shore A Durometer range shall be 35 to 85 with a thickness of not less than 0.090 inch.

3.3.4.1.2 Class H. The hermetic sealing of class H connectors shall be accomplished by the use of vitreous material. The mating faces of pin inserts shall be resilient material within a Shore A Durometer range of 35 to 55.

## MIL-DTL-5015H

3.3.5 Potting molds. Potting molds shall be made of polyamide conforming to L-P-410. The molds shall incorporate a means for attachment to the connector and shall accept and bond to MIL-PRF-8516 or MIL-PRF-23586 potting material without treatment by the user.

### 3.3.6 Shells, coupling rings, and backshells.

a. Connector shells and coupling rings, except for class D, H, and K, shall be made of aluminum alloys. Die castings, if used, shall conform to ASTM-B85, composition number GPASC84B.

b. Class D shells and coupling rings shall be made of a heat treated wrought aluminum alloy meeting the requirements of this specification.

c. Class H and K shells and coupling rings shall be made of ferrous alloy.

d. Class H, K, L, and U shells and coupling rings shall be made of non-magnetic corrosion-resistant steel in accordance with SAE-AMS-QQ-S-763, 300 series, or ASTM-A582, type XM-1 or 303. Class D and DJ shells and coupling rings shall be made of non-magnetic corrosion resistant steel in accordance with SAE-AMS-QQ-S-763, series 316 class.

e. Backshells shall be fabricated and finished with the same materials as the connectors.

#### 3.3.6.1 Finish. The resultant finish on all connectors shall be electrically conductive.

a. The finish of class A, B, C, E, F, P, and R connectors with aluminum alloy shells, coupling rings, and external screws shall be cadmium plated in accordance with QQ-P-416, type II, class 3. A preliminary plating of another metal is permissible. The resultant finish on cadmium plate connectors shall be olive drab (light to dark). Stainless steel in accordance with SAE-AMS-QQ-S-763 is an acceptable alternative for external screws.

b. The finish of class D connectors with wrought aluminum shells and coupling rings, class W connectors with aluminum alloy shells and coupling rings, and external screws for these classes shall be cadmium plated in accordance with QQ-P-416, type II, class 3 over nickel. The resultant finish on cadmium plated connectors shall be olive drab (light to dark). Stainless steel in accordance with SAE-AMS-QQ-S-763 is an acceptable alternative for external screws.

c. The finish of class H connectors with ferrous alloy shells and coupling rings, series II and series III class K connectors with ferrous alloy shells and coupling rings, and external screws shall be electroless nickel in accordance with ASTM-B733, class 3 or 4. A preliminary plating of another metal is permissible. Stainless steel in accordance with SAE-AMS-QQ-S-763 is an acceptable alternative for external screws.

MIL-DTL-5015H

d. The finish of series I class K connectors with ferrous alloy shells and coupling rings, series II and III class KT connectors with ferrous alloy shells and coupling rings, and external screws for these classes shall be cadmium plate in accordance with QQ-P-416, type II, class 3. The resultant finish on cadmium plated connectors shall be olive drab (light to dark). Stainless steel in accordance with SAE-AMS-QQ-S-763 is an acceptable alternate plating for external screws.

e. The finish of class DS connectors with corrosion-resistant steel shells and coupling rings shall be cadmium plate in accordance with QQ-P-416, type II, class 3, color - black. All other classes of connectors with corrosion-resistant steel shells and coupling rings shall be passivated.

f. The finish of class HT connectors with ferrous alloy shells and coupling rings, and external screws shall be electrically conductive fused tin. Stainless steel in accordance with SAE-AMS-QQ-S-763 is an acceptable alternate plating for external screws.

g. The finish of class L and U connectors with aluminum alloy shells and coupling rings, and external screws shall be electroless nickel in accordance with ASTM-B733, class 3 or 4. Stainless steel in accordance with SAE-AMS-QQ-S-763 is an acceptable alternative for external screws.

3.4 Design and construction. Connectors and accessories shall be designed and constructed to withstand handling incident to installation and maintenance in service. The connectors and accessories shall conform to the following:

Crimp contact connectors, back end configuration except MS3402, MS3412, MS3452, SAE-AS34021, and SAE-AS34121	figure 1
Connector, front release, series II interface dimensions	figures 2 and 3
Connector, rear release series III, and hermetic, interface dimensions	figures 4, 5, and 6
Connector solder contact (pin and socket) series I configuration	figure 7
Accessories to be used with series II and series III connectors	MIL-C-85049

3.4.1 Contacts. Contacts shall conform to MIL-C-39029 except as otherwise required herein for solder contact connectors. Contacts shall be designed so that neither the pin nor socket contacts are damaged during mating of counterpart connectors. The quantity of crimp contacts

## MIL-DTL-5015H

required for the connector plus one spare contact for connector arrangements having 26 contacts or less and two spare contacts for arrangements over 26 contacts shall be included in the unit package. No spares shall be supplied with sizes 8, 4, and 0 contacts. For other than direct shipments to the Government, crimp contact connectors are permitted to be ordered without contacts (see 6.2).

3.4.1.1 Solder contacts. Solder contacts shall conform to figure 7.

3.4.1.1.1 Mating end. The entering end of socket contacts shall be rounded or chamfered to allow for misalignment of the entering pin. The socket contacts shall provide the spring action for maintaining the contacting pressure between the pin and the socket. Size 12 and 16 socket contacts shall be designed to exclude the entrance of a pin 0.005 inch larger than the allowable maximum diameter of a mating pin. Size 16 contacts shall pass the resistance probe damage test (see 4.6.22). Use of designs for solder type pin and socket contacts sizes 0, 4, and 8 which allow contacts to be readily removable from their inserts for soldering to their conductors is permitted.

3.4.1.1.2 Solder cups. Solder cups shall be designed so that during soldering no components are damaged and no liquid solder escapes. The solder cups shall be as indicated on figure 7. The solder cups of sizes 0, 4, and 8 shall be provided with a venthole or with other provisions to prevent trapping of air during soldering. The interior surface of solder cups for sizes 16 and 12, except thermocouple contacts, shall be completely tinned over 100 percent of the full circle portion and for at least 50 percent of the remainder of the solder well area. For sizes 0, 4, and 8 the interiors shall be completely tinned with solder conforming to J-STD-006, composition Sn60 or better commercial grade. If flux is used, flux residues and contaminants shall be completely removed without effecting the components. No excess solder shall be on the exterior of the solder cup.

MIL-DTL-5015H

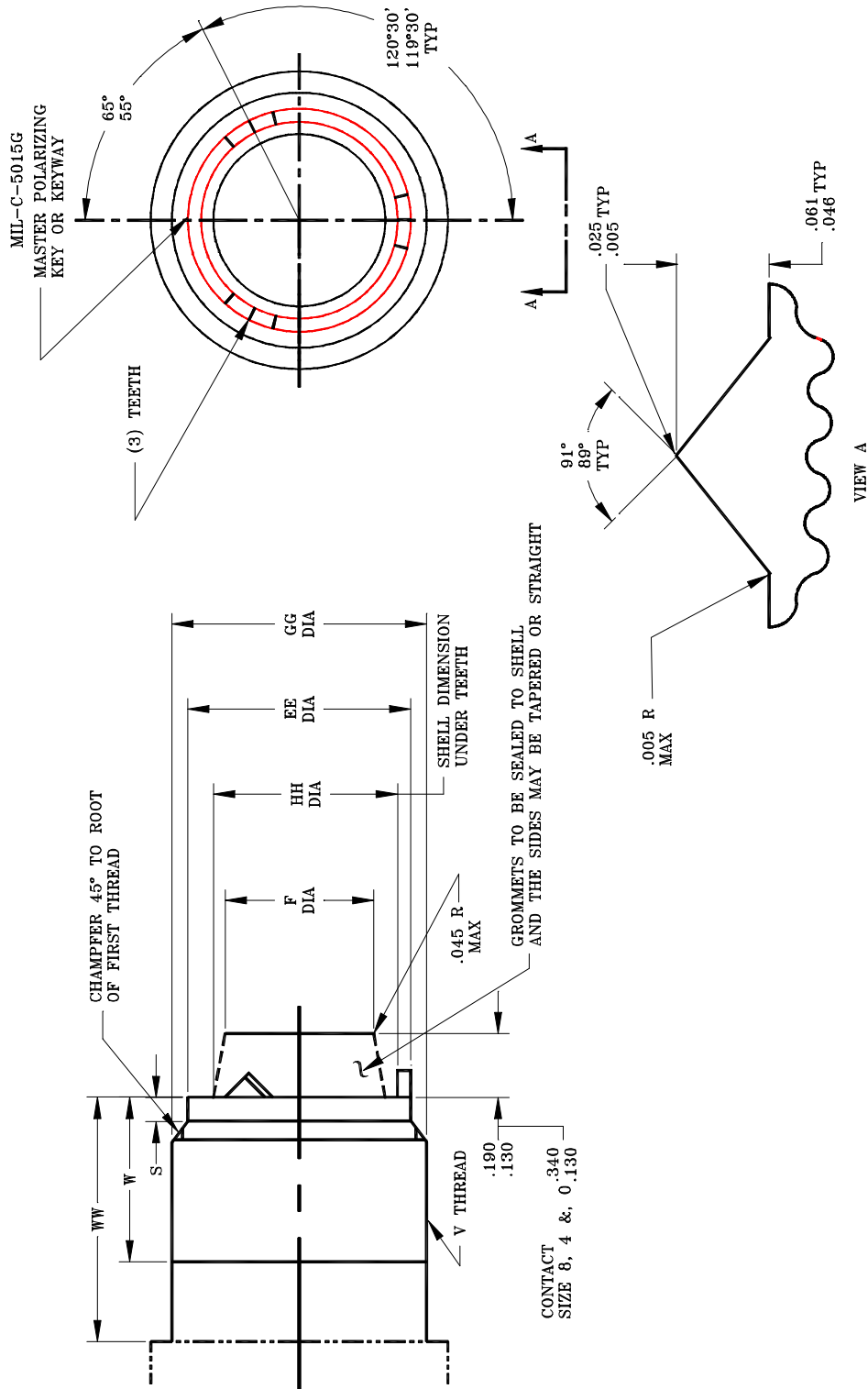

FIGURE 1. Crimp contacts connectors back end configuration except MS3402, MS3412, MS3452, SAE-AS34021 and SAE-AS34121

MIL-DTL-5015H

Shell size	V Thread class 2A	EE Dia	F Dia of any exposed portion of the grommet	GG +0.000 -0.010	HH ±0.005	S +0.005	W Min perf thread	WW Min <u>1</u> /
8S	.500-20 UNF	0.426/0.419	0.275/0.305	0.500	0.368	0.065	0.290	0.310
10S, 10SL	.625-24 UNEF	0.562/0.555	0.380/0.405	0.625	0.502			
12S, 12	.750-20 UNEF	0.679/0.672	0.516/0.549	0.750	0.618			
14, 14S	.875-20 UNEF	0.804/0.797	0.590/0.665	0.875	0.743			
16, 16S	1.000-20 UNEF	0.929/0.922	0.715/0.790	1.000	0.868			
18	1.0625-18 UNEF	0.984/0.977	0.794/0.869	1.062	0.924			
20	1.1875-18 UNEF	1.109/1.102	0.919/0.994	1.187	1.049			
22	1.3125-18 UNEF	1.234/1.227	1.044/1.119	1.312	1.174			
24	1.4375-18 UNEF	1.359/1.352	1.159/1.244	1.437	1.299			
28	1.750-18 UNS	1.613/1.603	1.394/1.465	1.750	1.520	0.095	0.467	0.487
32	2.000-18 UNS	1.863/1.853	1.640/1.715	2.000	1.770			
36	2.250-16 UN	2.113/2.103	1.855/1.930	2.250	1.985			
40	2.500-16 UN	2.363/2.353	2.070/2.145	2.500	2.200			
44	2.750-16 UN	2.613/2.603	2.325/2.400	2.750	2.455			
48	3.000-16 UN	2.858/2.848	2.575/2.650	3.000	2.705			

1/ Length to accommodate accessories

FIGURE 1. Crimp contact connectors back end configuration except MS3402, MS3412, MS3452, SAE-AS34021 and SAE-AS34121. - Continued

MIL-DTL-5015H

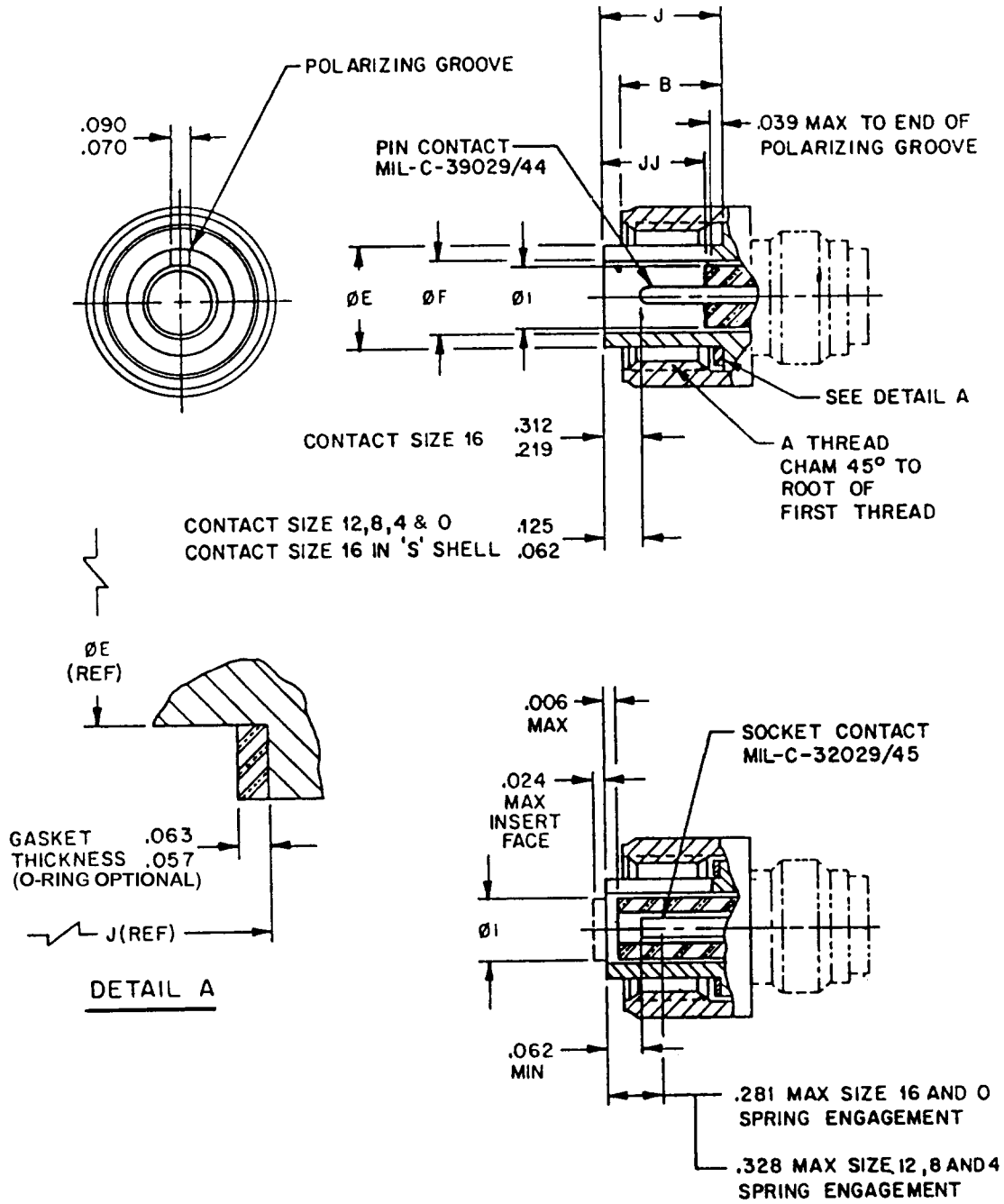

FIGURE 2. Connector, plug, front release, series II, interface dimensions.

MIL-DTL-5015H

Shell size	A Thread class 2B	B Dia +0.000 -0.062	E Dia +0.000 -0.010 <u>1/</u>	F Dia +0.015 -0.000 <u>1/</u>	I +0.000 -0.020	J ±0.005	JJ ±0.015
8S	.500-28 UNEF	0.414	0.365	0.252	0.250	0.570	0.501
10S	.625-24 UNEF		0.440	0.323	0.320		
10SL			0.446	0.398	0.397		
12S	.750-20 UNEF	0.664	0.555	0.450	0.448	0.757	0.689
12							
14S	.875-20 UNEF	0.414	0.675	0.526	0.525	0.570	0.501
14		0.664				0.757	0.689
16S	1.000-20 UNEF	0.414	0.805	0.651	0.650	0.570	0.501
16		0.664				0.757	0.689
18	1.125-18 UNEF		0.930	0.776	0.770		
20	1.250-18 UNEF		1.050	0.932	0.925		
22	1.375-18 UNEF		1.175	1.026	1.020		
24	1.500-18 UNEF		1.300	1.151	1.145		
28	1.750-18 UNS		1.520	1.370	1.365		
32	2.000-18 UNS		1.770	1.620	1.615		
36	2.250-16 UN		1.980	1.838	1.830		
40	2.500-16 UN		2.230	2.057	2.045		
44	2.750-16 UN		2.485	2.310	2.300		
48	3.000-16 UN	2.735	2.560	2.550			

1/ On shell size 10SL “E” dia tolerance is + 0.000, - 0.006 and “F” diameter tolerance is + 0.006, - 0.000.

FIGURE 2. Connector, plug, front release, series II interface dimensions - Continued.

MIL-DTL-5015H

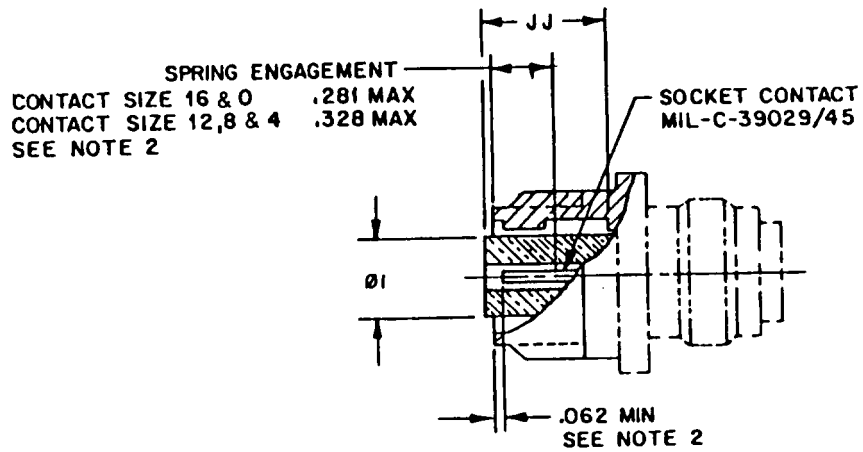
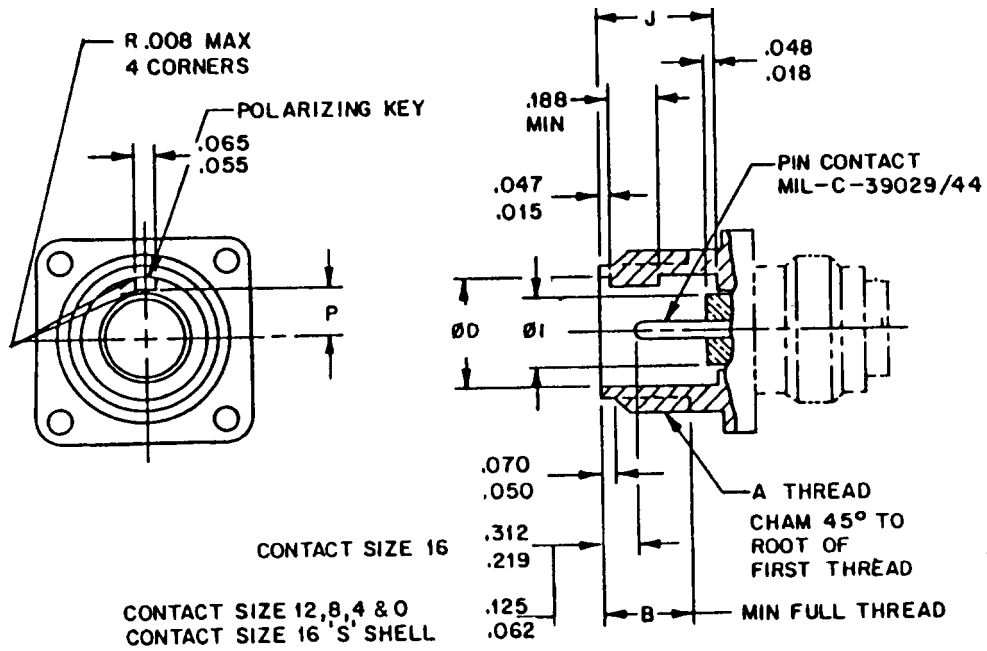

NOTES:

1. Dimensions are in inches.
2. For contact cavity insert interface dimensions see figure 6.

FIGURE 3. Connector, receptacle, front release, series II interface dimensions.

MIL-DTL-5015H

Shell size	A Thread class 2A	B Min thread	D Dia +0.015 -0.000	I Dia +0.000 -0.020	J ±0.005	JJ ±0.015	P +0.010 -0.000
8S	.500-28 UNEF	0.375	0.370	0.250	0.536	0.543	0.130
10S	.625-24 UNEF		0.448	0.320			0.165
10SL			0.397				
12	.750-20 UNEF	0.625	0.558	0.448	0.724	0.731	0.224
12S		0.375			0.536	0.543	
14	.875-20 UNEF	0.625	0.678	0.525	0.724	0.731	0.263
14S		0.375			0.536	0.543	
16	1.000-20 UNEF	0.625	0.808	0.650	0.724	0.731	0.325
16S		0.375			0.536	0.543	
18	1.125-18 UNEF	0.625	0.933	0.770	0.724	0.731	0.385
20	1.250-18 UNEF		1.053	0.925			0.463
22	1.375-18 UNEF		1.178	1.020			0.510
24	1.500-18 UNEF		1.303	1.145			0.573
28	1.750-18 UNS		1.523	1.365			0.683
32	2.000-18 UNS		1.773	1.615			0.808
36	2.250-16 UN		1.985	1.830			0.915
40	2.500-16 UN		2.237	2.045			1.023
44	2.750-16 UN		2.492	2.300			1.150
48	3.000-16 UN		2.742	2.550			1.275

FIGURE 3. Connector, receptacle, front release, series II interface dimensions - Continued.

MIL-DTL-5015H

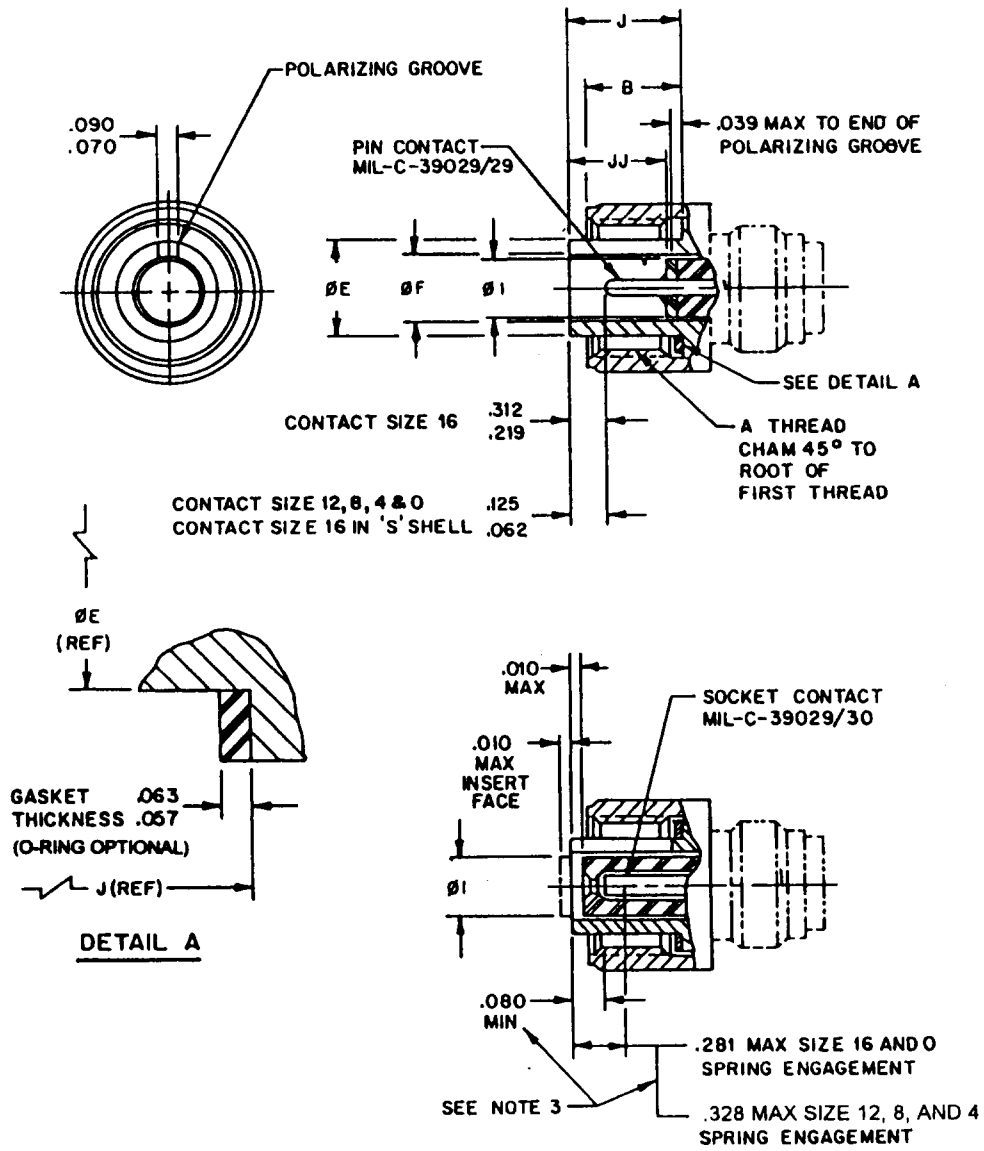

NOTES:

1. Dimensions are in inches.
2. For contact insert interface dimensions see figure 6.
3. Noted dimensions apply with contact fully seated back against contact retaining device.

FIGURE 4. Connector, plug, rear release, series III, interface dimensions.

MIL-DTL-5015H

Shell size	A Thread class 2B	B Dia +0.000 -0.062	E <u>1</u> / Dia +0.000 -0.010	F <u>1</u> / Dia +0.015 -0.000	I Dia +0.000 -0.020	J ±0.005	JJ ±0.011
8S	.500-28 UNEF	0.414	0.365	0.252	0.250	0.570	0.510
10S	.625-24 UNEF		0.440	0.323	0.320		
10SL			0.446	0.398	0.397		
12S	.750-20 UNEF	0.664	0.555	0.450	0.448	0.757	0.698
12							
14S	.875-20 UNEF	0.414	0.675	0.526	0.525	0.570	0.510
14		0.664				0.757	0.698
16S	1.000-20 UNEF	0.414	0.805	0.651	0.650	0.570	0.501
16		0.664				0.757	0.698
18	1.125-18 UNEF		0.930	0.776	0.770		
20	1.250-18 UNEF		1.050	0.932	0.925		
22	1.375-18 UNEF		1.175	1.026	1.020		
24	1.500-18 UNEF		1.300	1.151	1.145		
28	1.750-18 UNS		1.520	1.370	1.365		
32	2.000-18 UNS		1.770	1.620	1.615		
36	2.250-16 UN		1.980	1.838	1.830		
40	2.500-16 UN		2.230	2.057	2.045		
44	2.750-16 UN		2.485	2.310	2.300		
48	3.000-16 UN	2.735	2.560	2.550			

1/ On shell size 10SL “E” dia tolerance is + 0.000, - 0.006 and “F” diameter tolerance is + 0.006, -0.000.

FIGURE 4. Connector, plug, rear release, series III interface dimensions - Continued.

MIL-DTL-5015H

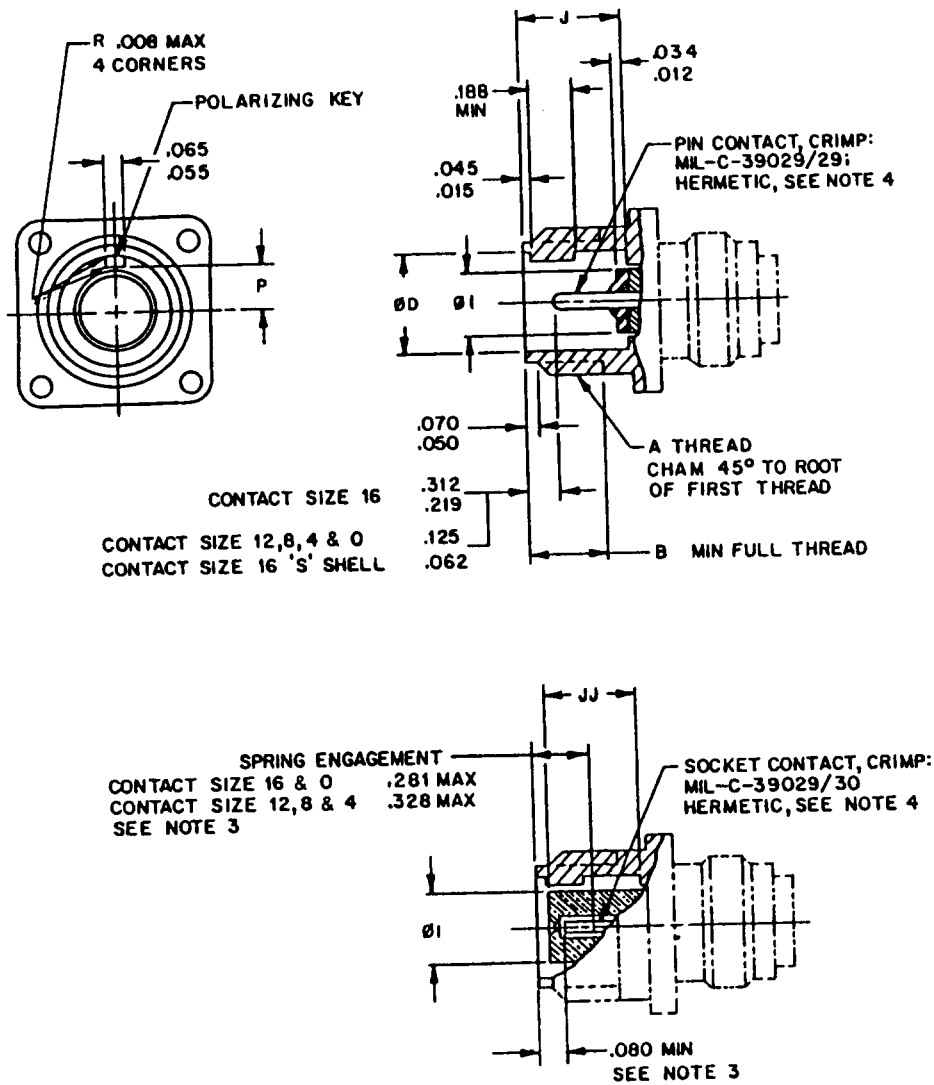

NOTES:

1. Dimensions are in inches.
2. For contact cavity insert interface dimensions see figure 6.
3. Noted dimensions apply with contact fully seated back against contact retaining device.
4. Hermetic connector contacts shall be fixed solder type contacts with mating end conforming to figure 7 socket or pin detail as required.

FIGURE 5. Connector, receptacle, rear release, series III and hermetic, interface dimensions.

MIL-DTL-5015H

Shell size	A Thread class 2A	B Min thread	D Dia +0.015 -0.000	I Dia +0.000 -0.020	J ±0.005	JJ ±0.015	P +0.010 -0.000
8S	.500-28 UNEF	0.375	0.370	0.250	0.536	0.533	0.130
10S	.625-24 UNEF		0.448	0.320			0.165
10SL				0.397			
12	.750-20 UNEF	0.625	0.558	0.448	0.724	0.731	0.224
12S		0.375			0.536	0.533	
14	.875-20 UNEF	0.625	0.678	0.525	0.724	0.721	0.263
14S		0.375			0.536	0.533	
16	1.000-20 UNEF	0.625	0.808	0.650	0.724	0.721	0.325
16S		0.375			0.536	0.533	
18	1.125-18 UNEF	0.625	0.933	0.770	0.724	0.721	0.385
20	1.250-18 UNEF		1.053	0.925			0.463
22	1.375-18 UNEF		1.178	1.020			0.510
24	1.500-18 UNEF		1.303	1.145			0.573
28	1.750-18 UNS		1.523	1.365			0.683
32	2.000-18 UNS		1.773	1.615			0.808
36	2.250-16 UN		1.985	1.830			0.915
40	2.500-16 UN		2.237	2.045			1.023
44	2.750-16 UN		2.492	2.300			1.150
48	3.000-16 UN		2.742	2.550			1.275

FIGURE 5. Connector, receptacle, rear release, series III and hermetic, interface dimensions - Continued.

MIL-DTL-5015H

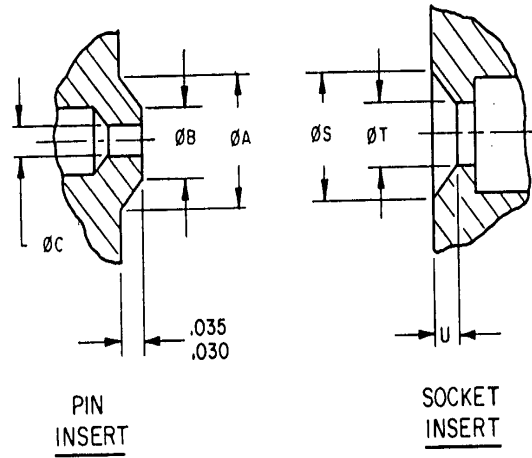

Contact Size	A Dia	B Dia	C Dia	S Dia	T Dia	U
16	0.150	0.135	0.061	0.140	0.079	0.035
	0.140	0.131	0.058	0.130	0.072	0.031
12	0.208	0.188	0.093	0.204	0.111	0.040
	0.198	0.184	0.090	0.193	0.104	0.035
8	0.310	0.270	0.141	0.306	0.159	0.040
	0.300	0.265	0.138	0.295	0.152	0.035
4	0.396	0.355	0.224	0.392	0.262	0.033
	0.386	0.350	0.221	0.381	0.234	0.027
0	0.578	0.537	0.356	0.573	0.414	0.033
	0.568	0.533	0.353	0.563	0.366	0.027

NOTE:

Dimensions are in inches.

FIGURE 6. Connector, rear release, series III, insert entry dimensions.

MIL-DTL-5015H

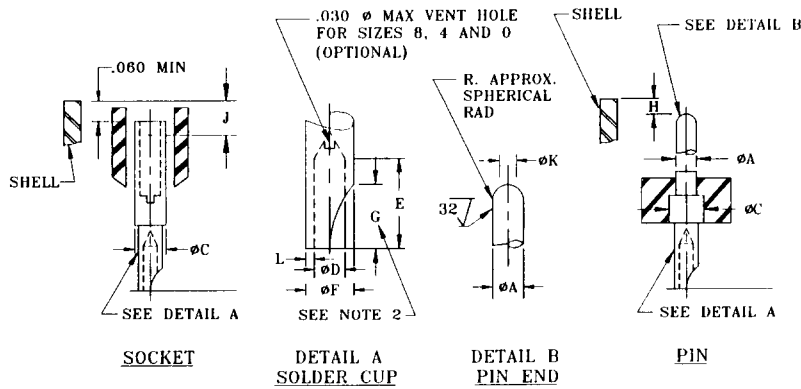

Contact size	A $\pm 0.001$ Dia <u>1/</u>	C Max Dia <u>2/</u>	D Min Dia	E $+0.063$ $-0.000$	F Dia Max	H Plug min	H Recpt max	J Max plug and rept <u>3/</u>	K Dia of flat	L min
16	0.0625	0.127	0.069	0.250	0.116	0.250	0.312	0.281	0.032 max	0.007
16S <u>4/</u>	0.0625	0.127	0.069	0.250	0.116	0.062	0.125	0.281	0.032 max	0.007
12	0.094	0.190	0.112	0.375	0.154	0.062	0.125	0.375	0.032 max	0.009
8	0.142	0.310	0.205	0.500	0.268	0.062	0.125	0.375	0.032 max	0.017
4	0.225	0.441	0.328	0.625	0.398	0.062	0.125	0.375	0.105 $\pm 0.021$	0.021
0	0.357	0.597	0.464	0.625	0.550	0.062	0.125	0.281	0.237 $\pm 0.021$	0.021

1/ Applies after plating.

2/ Used for calculating mechanical spacing between contacts and between contacts and shell.

3/ Represents the distance from the end of the shell to the point at which the mating pin engages the socket contact spring.

4/ Dimensions shown are typical for shell sizes 8S, 10S, 10SL, 12S, 14S, and 16S.

NOTES:

1. Dimensions are in inches.

2. Sizes 12 and 16: G max = 2/3 E, radius of cutout optional.

Sizes 0, 4, and 8: Cutout optional.

FIGURE 7. Solder contact (pin and socket), series I configuration.

## MIL-DTL-5015H

3.4.1.2 Crimp contacts. Crimp contacts shall be designed to prevent damage to the contact retention device or sealing member during insertion or removal of the contact. Front release crimp contacts shall conform to MIL-C-39029/44 and MIL-C-39029/45 and be qualified to MIL-C-39029. Rear release contacts shall conform to MIL-C-39029/29 and MIL-C-39029/30 and be qualified to MIL-C-39029.

3.4.1.2.1 Installing and removal tools (front release connectors). The individual contacts shall be positively retained in the connector when installed with the applicable MIL-I-81969/17 contact insertion tool. The individual contacts shall be capable of being removed from the connector when using the applicable MIL-I-81969/19 contact removal tool.

3.4.1.2.2 Installing and removal tools (rear release connectors). The individual contacts shall be positively retained in the connector when installed with the applicable MIL-I-81969/14 contact insertion tool. The individual contacts shall be capable of being removed from the connector when using the applicable qualified MIL-I-81969/14, and /15 contact removal tool.

3.4.2 Insert design and construction. Inserts shall be of voidless construction and secured to prevent rotation within the shell.

3.4.2.1 Insert retention.

3.4.2.1.1 Resilient inserts. All resilient inserts shall be nonremovable from the shell.

3.4.2.1.2 Hard material inserts. Hard material inserts for class A and B connectors having provisions for more than one alternate position shall be removable from the shell. However, they shall be retained within the shell when the conduit nut or adapter is removed.

3.4.2.2 Insert positioning. Inserts shall be installed in the position indicated in the applicable MS sheet. Removable inserts shall be keyed to prevent rotation with respect to the shell. Slots and markings for any of the alternate positions, as well as specific design details, shall be as specified in MIL-STD-1651 (see 6.6.7).

3.4.2.2.1 Crimp contact inserts. Crimp contact inserts shall be bonded to and non-removable from the shell.

3.4.2.3 Inserts for solder contact connectors. Inserts containing nonremovable solder contacts shall not be damaged by the solder process.

3.4.2.4 Inserts for crimp contact connectors. The insert and wire sealing grommet or insulating spacer of crimp contact connectors shall be one integral part and permit the removal and reinsertion of individual contacts without damage to the sealing members.

MIL-DTL-5015H

3.4.2.5 Contact arrangement. Contacts shall be arranged in accordance with MIL-STD-1651. Except for contacts in hard inserts, all solder cup openings, regardless of insert position, shall be oriented at right angles to and facing toward the key or keyway of the shell.

3.4.2.6 Contact spacing. Unless otherwise specified in MIL-STD-1651, minimum mechanical spacing and creepage distance shall be as shown in table I.

TABLE I. Minimum contact spacing.

Minimum contact spacing (inch)		
Service rating	Air spacing	Creepage distance
Instrument	----	1/16
A	1/16	1/8
D	1/8	3/16
E	3/16	1/4
B	1/4	5/16
C	5/16	1

3.4.2.7 Contact alignment. Inserts for socket contacts shall provide an overall sideplay of the socket contacts of 0.005 to 0.015 inch from the required position to facilitate alignment of mating pin contacts.

3.4.2.8 Contacts for class H connectors. Contacts shall be fused into the vitreous inserts of class H connectors. A resilient face gasket shall be bonded to the pin insert to ensure an interfacial seal in mating with an environmental resistant counterpart connector.

3.4.3 Screw threads. Screw threads intended to mate with parts of another approved manufacturer shall be UNEF, UNF, or NEF, class 2A or 2B, conforming to MIL-S-7742, except that 1-3/4-18 and 2-18 threads shall be UNS class 2A or 2B, conforming to FED-STD-H28. Screw threads shall be checked after plating by means of ring and plug gages only, in accordance with FED-STD-H28. Slight out-of-roundness beyond the tolerances of MIL-S-7742 is allowed if the threads can be checked without forcing the thread gages. Screw threads are permitted to be relieved provided the relief does not interfere with the performance of the screw threads (see 6.15).

3.4.4 Shell design. Connector shells shall be seamless, except for class B, and retain their inserts.

3.4.4.1 Lubrication. Connectors shall meet the requirements of this specification after all internal coupling ring threads have been coated with a lubricant.

## MIL-DTL-5015H

3.4.4.2 Snap rings and slots. When snap rings are used to retain the inserts in their shells in class A or B connectors, the snap rings shall be accessible, capable of repeated use, and of rectangular cross section. The snap ring slots shall have square sides and enough depth to prevent the snap ring from sliding, pulling, or twisting out of position.

3.4.4.3 Use of retaining devices. When retaining rings or other devices are used in the coupling ring retention system for plugs and accessories, the retention devices shall be positively captivated or utilized in such a manner that the plugs and accessories shall remain electrically functional as an assembled connector in the event of a retention device failure.

3.4.4.4 Rear release connectors. Connectors with rear release contact retention systems shall have blue color bands in accordance with the applicable MS standard.

3.4.5 Coupling connections. Threaded coupling rings shall be knurled and designed so that the pin and socket contacts engage or disengage as the ring is respectively tightened or loosened. The coupling rings of crimp contact connector plugs shall be captive to the shell. The quick disconnect plugs shall be provided with gripping surfaces and be fastened to receptacles by a device that engages receptacle threads, but can be pulled free in an emergency.

3.4.5.1 Safety wiring of coupling rings. All threaded coupling rings except SAE-AS34591 shall be designed for safety wiring. At least two holes shall be provided for shell sizes 14 and smaller, and at least three equally spaced holes for connector sizes 16 and larger. These holes shall be of a diameter to accommodate 0.032 inch diameter wire.

3.4.5.2 Shell polarization. Polarization of connectors shall be accomplished by matched integral key and keyway of counterpart connectors. The polarization of counterpart connectors shall take place before coupling rings are engaged.

3.4.5.3 Engagement seal. Pin contact connectors with resilient interfaces, except class A, shall contain sealing means so that the engaged contacts meet with the requirements of 3.4.1. The design of the seal shall be such that in mated connectors all air paths between adjacent contacts and between contacts and shells are eliminated. There shall be interfacial mating of the engaged connector insert to provide dielectric under compression of 0.005 inch minimum. Plug connectors shall have a peripheral seal. Connector plug shells with threaded coupling rings shall be provided with a static peripheral seal to ensure shell to shell sealing.

### 3.4.6 Wire sealing.

3.4.6.1 Class D, E, F, K, KS, KT, L, R, U, and W connectors. Class D, E, F, K, KS, KT, L, R, U, and W connectors, except MS3102, MS3402, MS3412, MS3452, SAE-AS34021, and SAE-AS34121 shall be provided with a wire sealing grommet capable of sealing on wires of the sizes specified in table II.

MIL-DTL-5015H

TABLE II. Wire range accommodations.

Contact size	Wire size	Outside diameter (OD) of finished wire (inch) <u>1/</u>					
		Solder contact connectors		Crimp contact connectors			
				Front release		Rear release	
		min <u>2/</u>	max	min <u>2/</u>	max	min <u>2/</u>	max
16-22 <u>3/</u>	26	N/A	N/A	0.066	0.130	N/A	N/A
	24						
	22						
16-16, 12-16 <u>4/</u>	20 18 16	0.064	0.130	0.066	0.130	0.053	0.103
12-12	14 12	0.114	0.170	0.097	0.170	0.085	0.158
8-8	10 8	0.164	0.255	0.132	0.255	0.132	0.255
4-4	6 4	0.272	0.370	0.237	0.370	0.237	0.370
0-0	2 0	0.415	0.550	0.360	0.550	0.360	0.550

1/ Wire reference MIL-W-16878, MIL-W-22759, MIL-DTL-81381, and MIL-C-915.

2/ For OD smaller than that specified, see 6.1.1.

3/ For series II only.

4/ Only crimp contact connector data applies to size 12-16 contacts.

Note: N/A Not applicable.

3.4.6.1.1 Solder contact connectors. Class F and R solder contact connectors shall be provided with a removable resilient grommet and retaining feature. The grommet shall be designed to fit against the rear face of the insert with the retaining feature in the installed condition. The design of the seal shall be such that in mated connectors all air paths between

## MIL-DTL-5015H

adjacent contacts and between contacts and shells are eliminated. There shall be interfacial mating of the engaged connector insert to provide dielectric under compression of not less than 0.005 inch. Connector plug shells with threaded coupling rings shall be provided with a static peripheral seal to ensure shell to shell sealing.

3.4.6.1.1.1 Class P connectors. Class P connectors shall be provided with a plastic potting form capable of accepting and bonding to MIL-PRF-8516 or MIL-PRF-23586 potting material. Inserts of class P connectors shall be designed so that potting material adheres to the shell and insert without treatment by the user.

3.4.6.1.1.2 Class H connectors. Class H connectors shall not be supplied with a wire sealing grommet. However, the shells and inserts shall be designed so that MIL-PRF-8516 or MIL-PRF-23586 potting compound adheres to the insert without treatment by the user.

3.4.6.1.2 Crimp contact connectors. Crimp contact connectors shall be provided with an integral grommet and insert.

3.4.6.1.2.1 Grommet sealing plugs. Grommets shall be designed to accept sealing plugs in accordance with MS3187 or MS27488, in lieu of wire where unused contacts are employed. Except for contact sizes 0 and 4, sealing plugs for 15 percent of the number of contacts, but not less than one sealing plug shall be enclosed in the unit package. For indirect shipments, connectors are permitted to be ordered without grommet sealing plugs (see 6.2). For insert arrangements containing one contact of a particular size, sealing plugs shall not be supplied (see 6.2).

### 3.5 Intermateability and interchangeability.

3.5.1 Intermateability. Connectors shall be intermateable. When different types of connectors (front or rear release) or different types of contacts (crimp or solder) are used in a mated pair of connectors, the applicable requirements specified herein for the type or class shall be met.

3.5.2 Interchangeability. All connectors and accessories having the same part number shall be completely interchangeable with each other with respect to installation (physical) and performance (function) as specified herein.

3.6 Magnetic permeability (except classes H and K). The relative magnetic permeability of connectors and accessories and connectors with thermocouple contacts shall be not greater than 2.0 when tested in accordance with 4.6.2.

## MIL-DTL-5015H

3.7 Disengagement (MS3107, MS3507). The axial tension required to separate the plug shell (insert removed) from receptacle shall be  $8 \pm 4$  pounds, when tested in accordance with 4.6.3.

3.8 Temperature cycling (thermal shock). Connectors shall continue to meet the requirements of this specification after being subjected to the temperature extremes specified in 4.6.4.

### 3.9 Air leakage.

3.9.1 Solder contact receptacles (except class A, B, H, and P). The air leakage rate shall be not greater than one atmospheric cubic inch per hour ( $4.55 \times 10^{-3}$  cubic centimeters per second). The specified leakage rate shall apply through the connector and not through the flange and mounting surface area when tested in accordance with 4.6.5.1.

3.9.2 Class H receptacles. The air leakage rate shall not exceed 0.1 micron cubic foot per hour ( $1 \times 10^{-6}$  cubic centimeters per second) when tested in accordance with 4.6.5.2. The specified leakage rate shall apply through the connector and not through the flange and mounting surface area, unless solder mounted.

3.10 Contact retention. The axial displacement of crimp contacts shall not be greater than 0.025 inch and contacts shall be retained in their inserts when subjected to the axial loads specified in 4.6.6 or 4.6.6.1.

3.11 Dielectric withstanding voltage. Connectors shall show no evidence of breakdown or flashover when subjected to the test voltages and altitudes in accordance with 4.6.7. Corona shall not be considered as breakdown.

### 3.12 Vibration.

3.12.1 Sine vibration. Mated connectors shall not be damaged and there shall be no loosening of parts due to vibration. Counterpart connectors shall be retained in full engagement, and the interruption of electrical continuity shall be not longer than 10 microseconds when tested in accordance with 4.6.8.1 or 4.6.8.2.

3.12.2 Random vibration. A current discontinuity of 10 microseconds or more, disengagement of the mated connectors, evidence of cracking, breaking, or loosening of parts shall be cause for rejection when tested in accordance with 4.6.8.3.

3.13 Shock. Mated connectors shall not be damaged and there shall be no loosening of parts, nor shall there be an interruption of electrical continuity longer than 10 microseconds during the exposure to mechanical shock when tested in accordance with 4.6.9.

MIL-DTL-5015H

3.14 Humidity. Mated connectors shall withstand the applicable voltage in table III for 5 minutes minimum after being tested in accordance with 4.6.10.

TABLE III. Test voltages after humidity.

Service rating	Test voltage (volts-rms)
Instrument	300
A	750
D	1,350
E	1,875
B	2,575
C	4,500

3.15 Contact resistance. Contacts in the mated condition shall meet the ambient 25 °C (77 °F) contact resistance requirements of MIL-C-39029 except the potential drop of class H contacts shall be not greater than 125 mV initially or 200 mV after conditioning when tested in accordance with 4.6.11.

3.16 Durability. Counterpart connectors shall show no mechanical or electrical defects detrimental to the operation of the connector after 100 cycles of coupling and uncoupling for crimp contact connectors, or of mating and unmating for solder contact connectors when tested in accordance with 4.6.12.

3.17 Corrosion. Connectors shall show no exposure of the basis metal that will adversely effect performance when tested in accordance with 4.6.13.

3.18 Insulation resistance.

3.18.1 At room temperature. The insulation resistance shall be not less then 5000 megohms when tested in accordance with 4.6.14.1.

3.18.2 At elevated temperature-short time (solder type only). The insulation resistance shall be as shown on figure 8 when tested in accordance with 4.6.14.3.

3.18.3 At elevated temperature-long time. The insulation resistance shall be as shown on figure 8 when tested in accordance with 4.6.14.4.

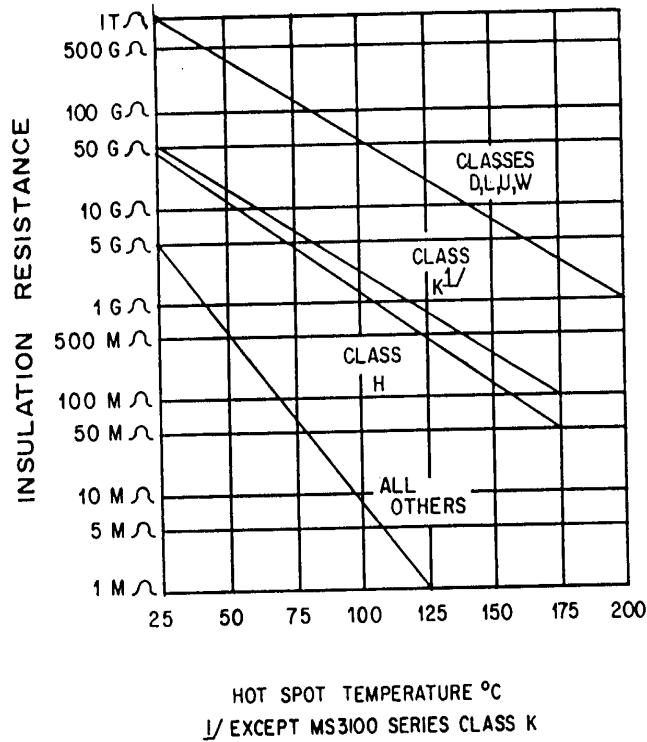

FIGURE 8. Minimum insulation resistance vs hot spot temperature.

3.19 Fluid immersion. Connectors shall mate with their counterpart connectors after fluid immersion in accordance with 4.6.15.

3.20 Firewall (class K connectors). Mated connectors shall prevent passing of a flame through the connector for at least 20 minutes when tested in accordance with 4.6.16. During this period there shall be no flame from outgassing or other causes on the end of the connector protected by the firewall. The current specified in table XV shall be applied for the first 5 minutes without a break in continuity. During the next minute the current drawn by the connector shall be not greater than 2 amperes when a test potential of 100-125 vac at 60 Hz is applied between adjacent contacts and between contacts and the shell.

3.21 Insert retention. Inserts shall not be dislocated from their original positions or damaged when they are subjected to the pressures specified in 4.6.17.

MIL-DTL-5015H

3.22 Moisture resistance. Mated connectors with rear accessory hardware assembled shall maintain an insulation resistance of 100 megohms or greater at 25 °C (77 °F) after being subjected to the moisture resistance test in accordance with 4.6.18.

3.23 Water pressure.

3.23.1 Solder contact receptacles (except classes A, B, H, K, and P). When tested in accordance with 4.6.19.1, receptacle inserts and panel seals shall show no leakage. In addition, there shall be no evidence of leakage at the interface of mated connectors. At the end of 48 hours while still immersed, the insulation resistance of mated connectors shall be not less than 100 megohms. After removal of unmated connectors from the immersion tank, the insulation resistance shall be not less than 100 megohms (see 4.6.19.1).

3.23.2 Crimp contact connectors. Mated connectors class D, L, U, and W assembled with MIL-C-85049/11 backshells insulation resistance shall be not less than 100 megohms after being subjected to the water pressure test. They shall show no evidence of entrance of water when tested in accordance with 4.6.19.2.

3.24 External bending moment. Connectors shall exhibit no evidence of damage, as revealed by inspection with 3X magnification, when stressed using the applicable bending moment in accordance with 4.6.20.

3.25 Contact engaging and separating forces (solder contacts). The socket contact engaging and separating forces shall be within the applicable limits specified in table IV when tested in accordance with 4.6.21.

TABLE IV. Contact engagement and separation forces.

Contact mating end size	Minimum separation force (ounces) minimum diameter SAE-AS31971 pin	Maximum average engagement force (ounces) maximum diameter SAE-AS31971 pin	Maximum engagement force (ounces) maximum diameter SAE-AS31971
16	2	33	48
12	3	56	80
8	5	N/A	160
4	10	N/A	240
0	15	N/A	320

Note: N/A – Not applicable.

MIL-DTL-5015H

3.26 Resistance to probe damage (size 16 solder socket contacts only). Socket contacts shall meet the engagement and separation force requirements specified in 3.25 after being subjected to the resistance to probe damage in accordance with 4.6.22.

3.27 Shell conductivity (crimp connectors). Mated connectors shall be electrically conductive from the plug accessory thread to the receptacle mounting flange or to the accessory thread on the cable connecting plug. The overall dc resistance shall be not greater than 0.005 ohm for class D and W or 0.05 ohm for all other classes when measured in accordance with 4.6.23.

3.28 Contact insertion and removal forces (crimp connectors). The forces required to insert and remove unlocked contacts shall not exceed the requirements specified in table V when tested in accordance with 4.6.24.

TABLE V. Contact insertion and removal forces.

Contact size	Insertion and removal forces (pounds, maximum)
16	20
12	25
8	30
4	40
0	40

3.29 Altitude immersion (series III only). The mated connectors insulation resistance shall be not less than 1000 megohms when tested in accordance with in 4.6.25. Any evidence of dielectric breakdown or flashover shall be cause for rejection.

3.30 Marking. Each connector shall be legibly and permanently marked on the shell or coupling ring in accordance with MIL-STD-1285. An example of the military part number is shown in 6.6. The date code, manufacturer name, symbol or code, and assembly plant symbol or code is required for all connector types. Metal stamping of part numbers is acceptable after plating. Metal impression marking, if used, shall show no exposure of unprotected basis metal which will adversely affect performance. Marking shall be legible after corrosion testing (see 3.17 and 4.6.13). Manufacturers' symbols or trademark shall be listed in SAE-AIR1351.

## MIL-DTL-5015H

3.30.1 Insert marking. Inserts shall be marked as specified in MIL-STD-1651. Manufacturer's identification is permitted. Raised or depressed characters shall not be used on insert mating faces for any markings of crimp contact connectors.

3.30.1.1 Contact designations. Contact identification on crimp contact connector inserts shall be designated by identifiable letters or numbers of contrasting color. Contact identification on solder contact inserts by use of contrasting color is permissible. Positioning and arrangement of the characters shall be such that the contact cavity is readily identifiable. All contacts shall be designated on the front face of the insert. Eighty percent of the characters on any face of the connector shall remain identifiable after completion of the tests specified in tables VI and VII.

3.30.1.1.1 Grommet and insulating spacers. Wire openings on the rear face of grommets and insulating spacers shall be marked with legible characters corresponding to the insert contact designators. Raised, depressed, or contrasting colored characters shall be used. It is permissible to identify only those wire openings which are located on the vertical centerline of the grommets of solder contact connectors.

3.30.2 Use of MS sheet designations. MS sheet designations shall not be applied to a product, except for qualification test samples (see 6.14), until notification has been received from the activity responsible for qualification that the product has been approved for listing on the qualified products list (QPL).

3.30.3 JAN brand. The United States Government has adopted, and is exercising legitimate control over the certification marks, "JAN" and "J", respectively, to indicate that items so marked or identified are manufactured to, and meet all the requirements of specifications. Accordingly, items acquired to, and meeting all the criteria specified herein and in applicable specifications shall bear the certification mark "JAN" except that items too small to bear the certification mark "JAN" shall bear the letter "J". The "JAN" or "J" shall be placed immediately before the part number except that if such location would place a hardship on the manufacturer in connection with such marking, the "JAN" or "J" may be located on the first line above or below the part number. Items furnished under contracts or orders which either permit or require deviation from the conditions or requirements specified herein or in applicable specifications shall not bear "JAN" or "J". In the event an item fails to meet the requirements of this specification and the applicable specification sheets or associated specifications, the manufacturer shall remove completely the military part number and the "JAN" or "J" from the sample tested and also from all items represented by the sample. The "JAN" or "J" certification mark shall not be used on products acquired to contractor drawings or specifications. The United States Government has obtained Certificate and Registration Number 504,860 for the certification mark "JAN" and Registration Number 1,586,261 for the certification mark "J".

MIL-DTL-5015H

3.31 Workmanship. Loose contacts, poor molding fabrication, loose materials, defective bonding, damaged or improperly assembled contacts, peeling, or chipping of plating or finish, galling of mating parts, nicks and burrs of metal parts, and warping of the post molding shall be a basis for rejection of items.

TABLE VI. Qualification inspection for solder contact connectors.

Inspection	Requirement paragraph	Test paragraph
Group 1		
Visual and mechanical	3.1, 3.3, 3.4, 3.5, 3.30, and 3.31	4.6.1
Magnetic permeability (except class K)	3.6	4.6.2
Disengagement (MS3107, MS3507 plug only)	3.7	4.6.3
Temperature cycling	3.8	4.6.4
Contact retention	3.10	4.6.6.1
Dielectric withstanding voltage	3.11	4.6.7.1
Vibration	3.12.1	4.6.8.1
Dielectric withstanding voltage	3.11	4.6.7.1
Shock	3.13	4.6.9.1
Humidity	3.14	4.6.10
Dielectric withstanding voltage	3.11	4.6.7.4
Contact resistance	3.15	4.6.11
Durability	3.16	4.6.12
Corrosion	3.17	4.6.13
Contact resistance	3.15	4.6.11
Insulation resistance (long time)	3.18.3	4.6.14.4
Fluid immersion	3.19	4.6.15.1
Visual and mechanical	3.1, 3.3, 3.4, 3.5, 3.30, and 3.31	4.6.1
Group 2		
Visual and mechanical	3.1, 3.3, 3.4, 3.5, 3.30, and 3.31	4.6.1
Firewall	3.20	4.6.16
Group 3		
Visual and mechanical	3.1, 3.3, 3.4, 3.5, 3.30, and 3.31	4.6.1
Magnetic permeability	3.6	4.6.2
Temperature cycling	3.8	4.6.4
Air leakage	3.9	4.6.5.1
Contact retention	3.10	4.6.6.1
Insert retention	3.21	4.6.17

MIL-DTL-5015H

TABLE VI. Qualification inspection for solder contact connectors - Continued.

Inspection	Requirement paragraph	Test paragraph
Dielectric withstanding voltage	3.11	4.6.7.1
Vibration	3.12.1	4.6.8.1
Dielectric withstanding voltage	3.11	4.6.7.1
Shock	3.13	4.6.9.1
Moisture resistance	3.22	4.6.18.2
Contact resistance	3.15	4.6.11
Durability	3.16	4.6.12
Corrosion	3.17	4.6.13
Contact resistance	3.15	4.6.11
Insulation resistance (short time)	3.18.2	4.6.14.3
Fluid immersion	3.19	4.6.15.1
Visual and mechanical	3.1, 3.3, 3.4, 3.5, 3.30, and 3.31	4.6.1
Group 4		
Visual and mechanical	3.1, 3.3, 3.4, 3.5, 3.30, and 3.31	4.6.1
Temperature cycling	3.8	4.6.4
Air leakage	3.9.1	4.6.5.2
Dielectric withstanding voltage	3.11	4.6.7.1
Insulation resistance	3.18.1	4.6.14.1
Durability	3.16	4.6.12
Vibration	3.12.1	4.6.8.1
Shock	3.13	4.6.9.1
Moisture resistance	3.22	4.6.18.2
Corrosion	3.17	4.6.13
Contact resistance	3.15	4.6.11
Insert retention	3.21	4.6.17
Visual and mechanical	3.1, 3.3, 3.4, 3.5, 3.30, and 3.31	4.6.1
Group 5		
Visual and mechanical	3.1, 3.3, 3.4, 3.5, 3.30, and 3.31	4.6.1
Dielectric withstanding voltage	3.11	4.6.7.1
Insulation resistance	3.18.1	4.6.14.1
Fluid immersion	3.19	4.6.15.2
Visual and mechanical	3.1, 3.3, 3.4, 3.5, 3.30, and 3.31	4.6.1

MIL-DTL-5015H

TABLE VI. Qualification inspection for solder contact connectors - Continued.

Inspection	Requirement paragraph	Test paragraph
Group 6		
Contact engaging and separating forces	3.25	4.6.21
Resistance to probe damage (size 16 only)	3.26	4.6.22
Contact engaging and separating forces	3.25	4.6.21
Corrosion (5 contacts only)	3.17	4.6.13
Visual and mechanical	3.1, 3.3, 3.4, 3.5, 3.30, and 3.31	4.6.1

TABLE VII. Qualification inspection for crimp contact connectors.

Inspection	Requirement paragraph	Test paragraph
Group 1		
Visual and mechanical	3.1, 3.3, 3.4, 3.5, 3.30, and 3.31	4.6.1
Magnetic permeability (except class K)	3.6	4.6.2
Shell conductivity	3.27	4.6.23
Contact insertion and removal forces	3.28	4.6.24
Contact retention	3.10	4.6.6
Insulation resistance	3.18	4.6.14
Temperature cycling	3.8	4.6.4
Dielectric withstanding voltage	3.11	4.6.7.2
Water pressure (series II only)	3.23.2	4.6.19.2
Altitude immersion (series III only)	3.29	4.6.25
Durability (except dynamic corrosion classes)	3.16	4.6.12
Vibration (series II only)	3.12.1	4.6.8.1
Random vibration (series III only)	3.12.2	4.6.8.3
Shock	3.13	4.6.9
Moisture resistance	3.22	4.6.18
Corrosion (except dynamic corrosion classes)	3.17	4.6.13.2
Dynamic corrosion	3.17	4.6.13
Contact resistance	3.15	4.6.11
Insert retention	3.21	4.6.17
Contact retention	3.10	4.6.6
External bending moment	3.24	4.6.20
Visual and mechanical	3.1, 3.3, 3.4, 3.5, 3.30, and 3.31	4.6.1

MIL-DTL-5015H

TABLE VII. Qualification inspection for crimp contact connectors – Continued.

Inspection	Requirement paragraph	Test paragraph
Group 2		
Visual and mechanical	3.1,3.3,3.4, 3.5, 3.30, and 3.31	4.6.1
Insulation resistance	3.18	4.6.14.1
Dielectric withstanding voltage	3.11	4.6.7.2
Dielectric withstanding voltage (altitude)	3.11	4.6.7.3
Insulation resistance (long time)	3.18.3	4.6.14.4
Contact resistance	3.15	4.6.11
Dielectric withstanding voltage	3.11	4.6.7.2
Insert retention	3.21	4.6.17
Contact retention	3.10	4.6.6
Visual and mechanical	3.1, 3.3, 3.4, 3.5, 3.30, and 3.31	4.6.1
Group 3		
Visual and mechanical	3.1, 3.3, 3.4, 3.5, 3.30, and 3.31	4.6.1
Contact insertion and removal forces	3.28	4.6.24
Contact retention	3.10	4.6.6
Visual and Mechanical	3.1, 3.3, 3.4, 3.5, 3.30, and 3.31	4.6.1
Group 4		
Visual and mechanical	3.1, 3.3, 3.4, 3.5, 3.30, and 3.31	4.6.1
Firewall	3.20	4.6.16
Group 5		
Visual and mechanical	3.1, 3.3, 3.4, 3.5, 3.30, and 3.31	4.6.1
Insulation resistance	3.18	4.6.14
Dielectric withstanding voltage	3.11	4.6.7.2
Fluid immersion (class D, U, G, K, L, and W)	3.19	4.6.15
Dielectric withstanding voltage	3.11	4.6.7.2
Insert retention	3.21	4.6.17
Contact retention	3.10	4.6.6
Visual and mechanical	3.1, 3.3, 3.4, 3.5, 3.30, and 3.31	4.6.1

TABLE VII. Qualification inspection for crimp contact connectors – Continued.

Inspection	Requirement paragraph	Test paragraph
<b>Group 6</b>		
Visual and mechanical	3.1, 3.3, 3.4, 3.5, 3.30, and 3.31	4.6.1
Temperature cycling	3.8	4.6.4
Dielectric withstanding voltage	3.11	4.6.7.2
Durability	3.16	4.6.12
Moisture resistance	3.22	4.6.18.1
Contact resistance	3.15	4.6.11
Visual and mechanical	3.1, 3.3, 3.4, 3.5, 3.30, and 3.31	4.6.1
<b>Group 7 (class D only)</b>		
Visual and mechanical	3.1, 3.3, 3.4, 3.5, 3.30, and 3.31	4.6.1
Temperature cycling	3.8	4.6.4
Dielectric withstanding voltage	3.11	4.6.7
Water pressure	3.23.2	4.6.19.2
Vibration	3.12.1	4.6.8.2
High impact shock	3.13	4.6.9
Dielectric withstanding voltage	3.11	4.6.7
Visual and mechanical	3.1, 3.3, 3.4, 3.5, 3.30, and 3.31	4.6.1

3.32 Dust caps. Dust caps in accordance with MS90376 shall be placed on the end of each connector. Hermetic connectors require caps on both ends or some other means to prevent damage to the termination end of the connector.

#### 4. VERIFICATION

4.1 Classification of inspections. The inspection requirements specified herein are classified as follows:

- a. Qualification inspection (4.3).
- b. Conformance inspection (4.4).
- c. Periodic inspection (4.5).

## MIL-DTL-5015H

4.1.1 Inspection conditions. Unless otherwise specified herein, all inspections shall be performed under any combination of conditions within the following ranges. Any specified condition shall not affect the other two ambient ranges.

Temperature: 15 to 35 °C (59 to 95 °F).

Relative humidity: 30 to 80 percent.

Barometric pressure: 650 to 800 mm of mercury.

4.2 Test equipment and inspection facilities. Test and measuring equipment and inspection facilities shall perform the required inspections. The establishment and maintenance of a calibration system to control the accuracy of the measuring and test equipment shall be in accordance with ANSI-Z540.1.

4.2.1 Assembly plants. Assembly plants shall be listed on or be approved for listing on MIL-DTL-5015 qualified products list. The qualified connector manufacturer shall certify that the assembly plant is approved for the distribution of the manufacturer's parts. The assembly plant shall use only piece parts supplied by the qualified connector manufacturer. No testing other than visual examination is required of certified piece parts obtained from the qualified connector manufacturer, except when there is cause for rejection. Assemblies produced at the assembly plant shall be subjected to inspection to ensure that the assembly process conforms with that established at the qualified manufacturing plant. Quality control requirements, including Government inspection surveillance, shall be the same as required for the qualified connector manufacturer. Assembly plants shall list their symbols or trademarks in SAE-AIR1351.

4.3 Qualification inspection. Qualification inspection shall consist of the examinations and tests performed in the sequence specified in tables VI and VII on the qualification test samples specified in 4.3.2. After receipt of the letter of authorization from the agent responsible for qualification, the applicant shall submit one copy of his test reports (certified by the Government inspector indicating the extent to which the tests were witnessed) to the agent responsible for qualification.

4.3.1 Qualification of additional connectors. Qualification by similarity to qualified components or to components submitted for qualification is permissible when materials, designs, and manufacturing processes are similar. The manufacturer shall provide to the qualifying activity, full details of the similarities and differences of the components and manufacturing processes, and a proposed qualification test program which will address the differences. Testing shall not begin until the manufacturer's proposal has been approved or modified by the qualifying activity.

## MIL-DTL-5015H

4.3.2 Qualification samples. Samples of each item submitted for qualification shall be tested in the sequence specified in tables VI or VII, as required. Specific details on preparation of samples shall be as follows: Each connector subjected to qualification testing shall be provided with a counterpart connector for those tests requiring mating assemblies. The counterpart connectors provided for this purpose shall be new, previously qualified connectors or new connectors submitted for qualification testing. Manufacturers not producing mating connectors shall submit data substantiating that tests were performed with approved counterpart connectors. For crimp contact connectors, two cavities of each sample shall contain unwired contacts and sealing plugs in accordance with MS27488. Connectors with less than four contacts of a given contact size shall not have sealing plugs installed for that contact size.

4.3.2.1 Wire-to-contact assembly. Unless otherwise specified (see 4.3.2.7.4), connectors shall be wired using wire selected from those specified in table II. Where wired contacts are required, terminations shall be accomplished as specified in 4.3.2.1.1 or 4.3.2.1.2.

4.3.2.1.1 Solder contacts. Solder in accordance with J-STD-001 shall be used. For class H connectors, termination of wire to solder terminals shall be accomplished with solder conforming to J-STD-006, composition Ag 1.5 or Sn 10.

4.3.2.1.2 Crimp contacts. Crimp contacts shall be crimped with tools conforming to MIL-DTL-22520 as specified in MIL-C-39029 /29, /30, /44, or /45.

4.3.2.2 Solder contact connectors (class A, B, C, and P). Qualification samples and qualification tests for solder contact connectors in class A, B, C, and P shall consist of two complete connector assemblies of class A or C wall mounting receptacles and class A or B straight plugs, each with insert arrangements with the greatest number of contacts submitted for qualification in each shell size range, which shall pass the tests of table VI, group 1. Qualification testing of these samples qualifies other shell types and the balance of insert arrangements in class A, B, C, and P by similarity. Testing of solder contacts need not be performed if compliance of similar contacts has previously been demonstrated in conjunction with qualification testing of connectors of a different class.

4.3.2.3 Solder contact connectors (class H). Qualification samples and qualification tests for solder contact connectors in class H shall be as specified in 4.3.2.1 and 4.3.2.2.

4.3.2.3.1 Group 4. Two class H receptacles in each shell size range with insert arrangements with the greatest number of contacts for which qualification is desired, together with mating class D, F, L, P, R, U, or W straight plugs, shall pass the tests of table VI, group 4.

4.3.2.3.2 Group 5. Four class H receptacles from each shell size range (small range: 8S to 16; medium range: 18 to 28; and large range: 32 to 48) with insert arrangements representing typical manufacturing shall pass the group 5 tests of table VI. Where mating plugs are required

class K or L shall be used. Qualification testing of the samples qualifies all other shell types and the balance of shell sizes and insert arrangements in class H by similarity.

4.3.2.4 Solder contact connectors (classes F and R). Qualification samples and qualification tests for solder contact connectors in classes F and R shall consist of two complete connector assemblies, class R wall mounting receptacles and class F straight plugs, each with insert arrangements with the greatest number of contacts for which qualification is desired, in each shell size, which shall pass the tests of table VI, group 3. For test purposes, contacts shall be wired in accordance with 4.3.2.1 except that for each size contact, no more than two wires or 10 percent of the wires, whichever is greater, shall be the larger of the two sizes shown in table II. Qualification testing of these samples qualifies other shell types and the balance of insert arrangements in class F and R by similarity. Testing of solder contacts need not be performed if compliance of similar contacts has previously been demonstrated in conjunction with qualification testing of connectors of a different class.

4.3.2.5 Series I connectors (class K). Qualification samples and qualification tests for series I connectors in class K shall consist of the complete connector assemblies. Qualification testing of these samples qualifies other shell types and the balance of insert arrangements in class K by similarity.

4.3.2.5.1 Group 1. Two complete connector assemblies, class K wall mounting receptacles and straight plugs, each with insert arrangements with the greatest number of contacts for which qualification is desired, in each shell size, shall pass the tests specified in table VI, group 1.

4.3.2.5.2 Group 2. Two complete connector assemblies, class K wall mounting receptacles and straight plugs, from each shell size range with insert arrangement having the greatest number of contacts for which qualification is desired, shall be assembled with wire conforming to MIL-W-25308 and pass the tests specified in table VI, group 2.

4.3.2.6 Socket contacts for solder contact connectors, group 6. Twenty of each socket contact size and configuration used in the solder contact connectors shall pass the tests of table VI, group 6. Sockets which are not completely assembled prior to installation in the insert such as class H, socket style, are permitted to be provided and tested in connectors.

4.3.2.7 Crimp contact connectors. Qualification samples and qualification tests for crimp contact connectors in classes D, K, L, W, and U shall be as specified in the following paragraphs. Shell sizes are grouped into three ranges (small range: 8S to 16; medium range: 18 to 28; large range: 32 to 48) for qualification testing. Successful completion of the qualification tests in table VII qualifies:

- a. For the shell size submitted, all shell sizes and styles within the range.

## MIL-DTL-5015H

b. For the service ratings submitted, all contact arrangements complying with those service ratings.

4.3.2.7.1 Group 1. Two connectors of each class with insert arrangements in each shell size range (small, medium, and large) of each contact retention system to be qualified shall pass the group 1 tests of table VII. One sample shall have the pin insert in the plug and the socket insert in the receptacle. The other sample shall have the inserts reversed. One sample shall be terminated with wire approaching the minimum OD specified in table II, and the other with maximum OD wire. The connectors shall be tested with an MIL-C-85049/52 strain relief clamp assembled on the back threads or other appropriate backshell hardware. The receptacles shall be wall mounting.

4.3.2.7.2 Group 2. One connector of each class (for each service rating) with insert arrangements having the maximum contact density and of each contact retention system to be qualified shall pass the group 2 tests of table VII. The plug shall have socket inserts, and the receptacle pin inserts, and shall be terminated with the maximum OD wire specified in table II. Backshell hardware shall be the same as group 1, and the receptacles shall be wall mounted.

4.3.2.7.3 Group 3. Additional connectors shall be supplied to provide a minimum of 10 contact cavities of each contact size and of each contact retention system. These connectors shall pass the group 3 tests of table VII. Additional contact sizes are permitted to be qualified by completion of the group 3 tests.

4.3.2.7.4 Group 4 (class K only). One class K connector in each shell size range with insert arrangements representing typical manufacturing and of each contact retention system to be qualified shall pass the group 4 tests of table VII. Each connector shall be assembled with wire conforming to MIL-W-25038.

4.3.2.7.5 Group 5. Twelve class D, U, K, L, or W connectors with insert arrangements in the medium shell size range shall pass the group 5 tests of table VII. All samples shall have the socket insert in the plug and the pin insert in the receptacle and shall be terminated with maximum OD wire specified in table II. Backshell hardware shall be the same as group 1. If more than one contact retention system is to be qualified, a minimum of two connectors of each retention system shall be subjected to each test fluid.

4.3.2.7.6 Group 6 (front and rear release connector intermateability). If requested by the qualifying activity, one connector with insert arrangements of class D, K, L, W, and U in each shell size range and of each release system combination (one male plug with front release mated to female receptacle with rear release, one male plug with rear release mated to female receptacle with front release, one female plug with front release mated to male receptacle with rear release and one female plug with rear release mated to male receptacle with front release) shall pass the group 6 tests of table VII. Backshell hardware shall be the same as group 1 and the receptacles shall be wall mounting.

MIL-DTL-5015H

4.3.2.7.7 Group 7 (class D only). Two complete connector assemblies, class D wall mounting receptacles and straight plugs, each with insert arrangements with the greatest number of contacts in each shell size range shall pass the tests of table VII, group 7. One sample shall have the pin insert in the plug and the socket insert in the receptacle. The other sample shall have the socket insert in the plug and the pin insert in the receptacle. One connector shall be assembled with a MIL-C-85049/11 type B cable backshell and 6 feet of the applicable cable specified in table VIII. The remaining connector shall be assembled with an SAE-AS31091 boot and 6 feet of the applicable cable specified in table VIII.

- a. For the shell size range submitted, all shell sizes and styles within those ranges.
- b. For the service ratings submitted, all contact arrangements complying with those service ratings.

TABLE VIII. Test cable size. 1/, 2/

M85049/11 Backshell Dash Number	SAE-AS31091 Boot Dash Number (Type B)	MIL-DTL-5015 Shell Size	Cable OD Max
07/08	11	8S	0.432
11/12	12	10S/10SL	0.432
13/14	13	12/12S	0.432
116/117	13	14/14S	0.432
21/22	14	16/16S	0.700
27/28	14	18	0.750
33/34	15	20	0.750
41/42	15	22	0.750
47/48	16	24	0.750
55/56	16	28	0.750
65/66	17	32	1.250
71/72	17	36	1.250

MIL-DTL-5015H

TABLE VIII. Test cable size - Continued. 1/, 2/

M85049/11 Backshell Dash Number	SAE-AS31091 Boot Dash Number (Type B)	MIL-DTL-5015 Shell Size	Cable OD Max
79/80	18	40	1.250
87/88	18	44	1.250
95/96	18	48	1.250

1/ Select type to match maximum cable entry and insert configuration of MIL-DTL-5015.

2/ No armor to be used on test cable.

4.3.3 Qualification rejection. There shall be no failures during any examination or tests of the connectors or accessories submitted for qualification tests. After notification of any failure, the agent responsible for qualification testing (see 6.14) shall receive details of corrective action from the manufacturer before initiating any further tests deemed necessary to ensure compliance with connector requirements.

4.4 Conformance inspection.

4.4.1 Inspection of product for delivery. Inspection of product for delivery shall consist of group A inspection.

4.4.2 Group A inspection. Group A inspection shall consist of all of the applicable tests specified in table IX.

TABLE IX. Group A inspection.

Inspection <u>1/</u>	Requirement paragraph	Test paragraph
Visual and mechanical	3.1, 3.3, 3.4, 3.5, 3.30, and 3.31	4.6.1
Air leakage (for class H only) <u>2/</u>	3.9.2	4.6.5.2
Dielectric withstanding voltage <u>2/</u> , <u>3/</u>	3.11	4.6.7.5
Insulation resistance <u>2/</u> , <u>3/</u>	3.18.1	4.6.14.2

MIL-DTL-5015H

1/ 100 percent inspection.

2/ The contractor is permitted to use in-process controls for this requirement.

3/ Crimp contact connectors only.

4.5 Periodic inspection. Periodic inspection shall consist of group B. Except where the results of these inspections show noncompliance with the applicable requirements (see 4.5.1.4), delivery of products which have passed group A shall not be delayed pending the results of these periodic inspections.

4.5.1 Group B inspection. Group B inspection shall consist of the tests specified in table X in the order shown. Group B inspection shall be made on sample units selected from inspection lots which have passed the Group A inspection.

TABLE X. Group B inspection.

Inspection	Requirement Paragraph	Test Paragraph	Group					
			1	2	3	4	5	6
Insulation resistance	3.18	4.6.14	X	X	X	X	--	--
Dielectric withstanding voltage	3.11	4.6.7.2	X	X	X	X	--	--
Contact retention	3.10	4.6.6	X	X	--	--	X	X
Shell conductivity	3.27	4.6.23	--	--	--	--	X	X
Air leakage	3.9.1	4.6.5.1	X	--	--	X	--	--
Durability	3.16	4.6.12	--	X	--	X	--	X
Moisture resistance (except classes A, B, C, and K only)	3.22	4.6.18	X	--	X	--	X	--
Humidity (classes A, B, C, and K only)	3.14	4.6.10	X	--	--	--	--	--
Water pressure (series II only)	3.23.1	4.6.19.1	--	--	--	--	X	--
Altitude immersion (series III only)	3.29	4.6.25	--	--	--	--	X	--
Corrosion	3.17	4.6.13	--	X	--	X	--	X

## MIL-DTL-5015H

4.5.1.1 Sampling plan. Every 24 months, mated connector sample units which have passed group A inspection shall pass the tests specified in table X. Samples shall be selected to provide two samples per applicable test group, as determined by the contact type and the class of the samples to be tested.

4.5.1.1.1 Solder contact connectors (class A, B, C, E, F, K, P, and R). Samples and tests for solder contact connectors shall consist of four mating plugs and receptacles in various shell sizes and classes representing a cross section of production. Plugs and receptacles of different classes are permitted to be mated. The samples shall be wired as specified in 4.3.2.1. Two complete mating connector assemblies shall pass the tests of table X, group 1 and the other two assemblies shall pass the tests of table X, group 2.

4.5.1.1.2 Solder contact connectors (class H). Samples and tests for solder contact connectors shall consist of four receptacles with mating plugs in various shell sizes representing a cross section of production. Two complete mating connector assemblies shall be wired as specified in 4.3.2.1 and pass the tests of table X, group 3. The remaining two assemblies need not be wired but shall pass the tests of table X, group 4.

4.5.1.1.3 Crimp contact connectors. Samples and tests for crimp contact connectors shall consist of four mating plugs and receptacles in various shell sizes and classes representing a cross section of production. Plugs and receptacles of different classes are allowed to be mated. The samples shall be wired as specified in 4.3.2.1. Two complete mating connector assemblies shall pass the tests of table X, group 5, and the other two assemblies shall pass the tests of table X, group 6.

4.5.1.1.4 Solder socket contacts. Samples and tests for solder socket contacts shall be as specified in 4.3.2.6.

4.5.1.2 Failures. If one or more sample units fail to pass group B inspection, the sample shall be considered to have failed.

4.5.1.3 Disposition of sample units. Sample units which have been subjected to group B inspection shall not be delivered on the contract or purchase order.

### 4.6 Methods of examination and tests.

4.6.1 Visual and mechanical examination. The connectors, accessories, and piece parts shall be visually and mechanically examined to ensure conformance with 3.1, 3.3, 3.4, 3.5, 3.30, and 3.31. The use of in process controls to examine component parts, unrelated to lot sizes of finished connectors, is permitted in lieu of examination of these components in the finished connectors to ensure conformance of these component parts.

MIL-DTL-5015H

4.6.2 Magnetic permeability. The relative permeability shall be checked with an indicator conforming to ASTM-A342. The connectors or accessories are permitted to be wired or unwired, as convenient, but shall not carry current (see 3.6).

4.6.3 Disengagement (MS3107, MS3507). The plug (without the insert) shall be fully mated to a mounted receptacle. An increasing axial tension shall be applied to the plug and the force at separation measured (see 3.7).

4.6.4 Temperature cycling (thermal shock). Accessories or unmated connectors shall be tested in accordance with MIL-STD-1344, Method 1003, Test Condition A, except that the temperature extremes shall be as specified in table XI. At the completion of the last cycle, the connectors shall be returned to room temperature for inspection (see 3.8).

TABLE XI. Temperature extremes.

Class	Temperature		
	Extremes	Degrees C	Degrees F
A, B, C, E, F, P, R	Low	-55 +0 -3	-67 +0 -5
	High	+125 +3 -0	+257 +5 -0
D, H, K, W	Low	-55 +0 -3	-67 +0 -5
	High	+175 +3 -0	+347 +5 -0
L, U	Low	-55 +0 -3	-67 +0 -5
	High	+200 +3 -0	+392 +5 -0

4.6.5 Air leakage tests.

4.6.5.1 Solder contact receptacles (except class A, B, H, and P). The connector shall be tested for air leakage in accordance with MIL-STD-1344, Method 1008. The pressure differential across the connector shall be 30 lb/in<sup>2</sup>. The leakage rates shall be measured in both directions while at the low temperature extremes of table XI (see 3.9.1).

4.6.5.2 Class H receptacles. All class H receptacles shall be mounted in a manner which will allow for the application of 15 lb/in<sup>2</sup> nominal pressure differential across the receptacles and tested

MIL-DTL-5015H

in accordance with MIL-STD-1344, Method 1008. The leakage rate shall be determined while pressurized air or gas, containing not less than 10 percent of helium by volume, is applied to the receptacle (see 3.9.2).

4.6.6 Contact retention. Axial loads in accordance with table XII shall be applied to the mating end of the individual contacts. The connector shall have all contacts in place during the test in accordance with MIL-STD-1344, Method 2007 (see 3.10).

TABLE XII. Contact retention axial loads.

Contact mating end size	Minimum axial load (pounds)		
	Fixed type contacts	Removable crimp type contact, except class D	Class D
16	10	25	50
12	15	30	50
8	20	50	80
4	20	60	100
0	25	75	100

4.6.6.1 Solder contact connectors. Connectors shall be tested as specified in 4.6.6. The measurement of the displacement of the contacts is not required (see 3.10).

4.6.7 Dielectric withstanding voltage (see 3.11).

4.6.7.1 Dielectric withstanding voltage (sea level, solder contacts only). Wired, unmated connectors shall be tested in accordance with MIL-STD-1344, Method 3001, with the following details and exceptions:

- a. The magnitude of the test voltage shall be as specified in table XIII. (For maximum recommended working voltages, see 6.1.2).
- b. Fifty percent of the contacts available shall be tested, but in no case shall less than six dielectric withstanding voltage readings be taken. If the number of contacts is three or less, all contacts shall be tested. The test voltage shall be applied between each wired contact and each adjacent contact and the shell.

MIL-DTL-5015H

c. For acceptance testing, simulated contacts and special techniques are permitted to be used in performing this test.

TABLE XIII. Dielectric withstanding test voltages.

Service rating	Test voltage (volts-rms)	
	Sea level	70,000 ft
Instrument	1000	260
A	2000	360
D	2800	400
E	3500	440
B	4500	480
C	7000	560

4.6.7.2 Dielectric withstanding voltage (sea level, crimp contact connectors only). Mated or unmated connectors, as required, shall be tested in accordance with MIL-STD-1344, Method 3001. Fifty percent of the contacts shall be tested, but in no case shall less than six dielectric withstanding voltage readings be taken. If the number of contacts is three or less, all contacts shall be tested. The test voltage shall be applied between each wired contact and each adjacent contact and the shell. If an insert has more than one service rating, similar connections shall be made for the different test voltages as needed.

4.6.7.3 Dielectric withstanding voltage (altitude). Mated connectors and unmated connector halves with pin contacts shall be tested in accordance with MIL-STD-1344, Method 3001, with the following details and exceptions:

- a. The magnitude of the test voltage shall be as specified in table XIII.
- b. Fifty percent of the contacts available shall be tested, but in no case shall less than six dielectric withstanding voltage readings be taken. If the number of contacts is three or less, all contacts shall be tested. The test voltage shall be applied between each wired contact and each adjacent contact and the shell.
- c. The leads of all test circuits shall be brought out through the walls of the chamber. There shall be no wire splices inside the chamber. The wire ends of all leads shall be unsealed.
- d. Only the engaging faces of class H connectors shall be subjected to the high altitude. The rear face shall be protected.

## MIL-DTL-5015H

4.6.7.4 Dielectric withstanding voltage (after humidity at sea level). The mated connectors shall show no evidence of breakdown when the voltage indicated for the applicable service rating in table III is applied between the two closest contacts and between the shell and the contacts closest to the shell in accordance with MIL-STD-1344, Method 3001, except the test voltage shall be applied for 5 minutes (see 3.11).

4.6.7.5 Dielectric withstanding voltage (group A inspection at sea level). Unmated connectors or insert assemblies shall show no evidence of breakdown when the applicable test voltage of table XIII is applied between the two closest contacts, and between the shell (or simulated shell) and the contact closest to the shell in accordance with MIL-STD-1344, Method 3001. The period of application of voltage shall be two seconds minimum and simulated contacts are permitted to be used.

4.6.8 Vibration. Complete mated connectors shall be mounted and pass the applicable vibration test. Each receptacle shall be mounted on a fixture, which, in turn, shall be attached to a vibration table. A sensor shall monitor the vibration of the receptacle at a point on or near the receptacle. A counterpart plug shall be engaged with the receptacle and be attached without the use of safety wire. The wire bundles or cables shall be clamped to nonvibrating points at least 8 inches from the rear of the connectors. The clamping length shall be chosen to avoid resonance of the wire bundles or cables. All contacts shall be wired in a series circuit, and a current that shall be not greater than 100 milliamperes shall flow through the series circuit during the test. An instrument shall be employed to monitor the current flow and to indicate discontinuity of contact or interruption of current flow (see 3.12).

4.6.8.1 Sine vibration (solder contact connectors only). The mated connector shall be mounted as specified in 4.6.8 and vibrated in accordance with MIL-STD-1344, Method 2001, test condition II.

4.6.8.2 Sine vibration (series II only). Mated connectors shall be mounted as specified in 4.6.8 and tested in accordance with MIL-STD-1344, Method 2005, test condition III, and also in accordance with the endurance test of MIL-STD-167-1.

4.6.8.3 Random vibration (series III only). Wired, mated connectors shall be tested in accordance with to MIL-STD-1344, Method 2005. The following details shall apply:

- a. The connector shall be mounted on the table.
- b. Test condition VI - letter J.
- c. The duration of test shall be 8 hours in the longitudinal direction and 8 hours in the perpendicular direction.

## MIL-DTL-5015H

### 4.6.9 Shock (see 3.13).

4.6.9.1 Shock (except class D connectors). Mated connectors shall be tested in accordance with MIL-STD-1344, Method 2004, test condition A. Connectors shall be mounted and mated. All contacts shall be wired in a series circuit with a current that shall be not greater than 100 milliamps. The wire bundles or cables shall be clamped to structures that move with the connectors. A minimum of 8 inches of wire or cable shall be unsupported behind the rear of each connector.

4.6.9.2 High impact shock (class D connectors). Complete mated connectors with MIL-C-85049/11 backshells or SAE-AS31091 boots with 6 feet of unarmored cable (see table VIII) installed shall be tested in accordance with MIL-S-901, Grade A. Mounting fixtures shall be in accordance with MIL-S-901, lightweight. All contacts shall be wired in a series circuit with a current that shall be not greater than 100 milliamps flowing through the series circuit during the high impact shock. A device shall be used to monitor the current flow and to indicate any discontinuity which exceeds 10 microseconds interruption of current flow. The mated connectors shall be held together only by the locking device. Cable or wires shall be supported on a stationary frame not closer than 36 inches from the connector assembly.

4.6.10 Humidity. Mated connectors shall be exposed to a relative humidity in accordance with MIL-STD-1344, Method 1002, type 1, at a room temperature of  $71 \pm 2$  °C for 14 days. Immediately after exposure, without any forced drying, conduct the dielectric withstanding voltage test of 4.6.7.4. Class H receptacles and MS3102 receptacles shall have their rear portion enclosed and not exposed to humidity (see 3.14).

4.6.11 Contact resistance. The contact resistance shall be measured in accordance with MIL-STD-1344, Method 3004. Solder contact connectors shall be tested with the coupling ring removed (see 3.15 and 4.6.13.3).

4.6.12 Durability. Counterpart connectors shall be mated and unmated 100 times at a rate that shall not be greater than 60 cycles per hour in accordance with MIL-STD-1344, Method 2016 (see 3.16).

4.6.13 Corrosion. Unmated connectors and individual contact samples shall be tested in accordance with MIL-STD-1344, Method 1001. The samples shall not be mounted but suspended from the top of the chamber using waxed twine, string, glass rods, or glass cord. Wire ends shall be protected to prevent salt migration. The details and exceptions of this test shall be as specified in 4.6.13.1, 4.6.13.2, and 4.6.13.3 (see 3.17).

4.6.13.1 Corrosion (class A, B, C, E, F, P, R, and class H and MS3100 series class K ferrous alloy connectors). Test condition letter B.

## MIL-DTL-5015H

4.6.13.2 Corrosion (series II and series III class K ferrous alloy connectors and class L and U aluminum connectors). Test condition letter A. The connectors shall be subjected to the salt spray test for 48 hours mated followed by 48 hours unmated.

4.6.13.3 Dynamic corrosion (classes D, W, and DJ and class H, K, L, and U stainless steel connectors). Test condition letter D. The plugs and receptacles shall be mated and unmated 50 cycles at a rate that shall be not greater than 300 cycles per hour . The mating and unmating shall be accomplished so that the plugs and receptacles are completely separated during each cycle. The connectors shall then be subjected to the salt spray test for 952 hours mated, followed by 48 hours unmated. After salt spray exposure, the remaining number of durability cycles specified in 4.6.12 shall be completed.

### 4.6.14 Insulation resistance.

4.6.14.1 Insulation resistance at room temperature (see 3.18.1). Unmated connectors shall be tested in accordance with MIL-STD-1344, Method 3003. The following details and exceptions shall apply:

a. For lot acceptance testing simulated contacts and special techniques, as approved by the qualifying activity (see 6.2), are permitted to be used in performing this test.

b. The tolerance on the applied voltage shall be  $\pm 10$  percent.

4.6.14.2 Insulation resistance at room temperature (group A). Insulation resistance shall be measured in accordance with 4.6.14.1 between at least two closest adjacent contacts, and between the shell and at least one contact closest to shell. Simulated contacts and shells are permitted to be used (see 3.18.1).

4.6.14.3 Insulation resistance at elevated temperature (short time). The insulation resistance shall be measured in accordance with 4.6.14.1 except that the connectors shall have been exposed to an ambient temperature of 125 °C (257 °F) for 60 hours. After completion of the 60 hours and while at the 125 °C temperature, measurements shall be made. During the duration of the test sequence, and while at the 125 °C temperature measurements shall be made at least two times. The interval between each series of measurements shall be not less than 24 hours (see 3.18.2).

4.6.14.4 Insulation resistance at elevated temperature (long time). The insulation resistance shall be measured in accordance with 4.6.14.1. Elevated temperatures and required minimum insulation resistances are specified in table XIV. All measurements shall be made at the end of 1,000 hours while the connectors are at the elevated temperature (see 3.18.3).

MIL-DTL-5015H

TABLE XIV. Insulation resistance at elevated temperature (long time).

Class of connector	Minimum insulation resistance (megohms)	Test temperature +5 °C (41 °F) -0 °C (32 °F)
A, B, C, E, F, P, and R	30	85 °C (185 °F)
H	50	175 °C (347 °F)
K	100	175 °C (347 °F)
L, D, U, and W	1000	200 °C (392 °F)

4.6.15 Fluid immersion (see 3.19).

4.6.15.1 Limited capabilities (class A, B, C, E, F, P, and R). Unmated connectors shall be fully immersed in the fluids specified below for the required periods. At least one connector with its mating counterpart shall be immersed in each fluid. After removal from the fluid, each connector shall remain for 1 hour in air at room conditions. Connectors shall be fully mated with mating connectors that were immersed simultaneously in the same fluid.

- a. Hydraulic fluid conforming to MIL-H-5606 - 20 hours.
- b. Lubricating oil conforming to MIL-PRF-7808 - 20 hours.

4.6.15.2 Complete capabilities (class D, K, L, H, U, and W). Connector samples shall be tested in accordance with MIL-STD-1344, Method 1016 (one sample per fluid). Following the fluid immersion cycles, the connector shall be visually examined at 3X magnification for cracks and tears and shall be mated by hand.

4.6.16 Firewall (class K conductors). The mated, torqued, and wired connectors shall be tested in accordance with MIL-STD-1344, Method 1009 (see 3.20). The wire bundles shall be clamped to fixed points at least 8 inches behind the connectors. Test currents shall be as specified in table XV.

MIL-DTL-5015H

TABLE XV. Firewall test currents.

Contact size		DC test current (amperes)
Mating end	Wire barrel end	
16	16	22
12	12	41
8	8	73
4	4	135
0	0	245

4.6.17 Insert retention. Unmated connectors shall be tested in accordance with MIL-STD-1344, Method 2010 (see 3.21). The maximum pressure shall be as specified in table XVI.

TABLE XVI. Insert retention test pressures.

Shell size	Test pressure (psi gage)	
	All classes except H	Class H
8 through 12	150	200
14 through 18	100	
20 through 22	75	
24 through 28	60	
32 through 40	45	
44 through 48	30	

4.6.18 Moisture resistance. Moisture resistant test specimens shall be subjected to the high humidity (see 4.6.18.1) or extreme humidity range (see 4.6.18.2) moisture tests, as applicable. The connectors shall be wired and mated to the counterpart connectors. They shall be mounted horizontally with the wires descending into the backshell with no drip loops or splices within the chamber. The wires shall leave the chamber through vapor tight seals. Connectors without rear seal grommets shall have their terminals protected (see 3.22). Prior to the beginning of the test and at the end of the test period and while at the high humidity, the insulation resistance between each contact and other contacts shall be determined as specified in of MIL-STD-1344, Method 3003.

## MIL-DTL-5015H

4.6.18.1 Moisture resistance at high humidity (crimp contact connectors). Wired, mated connectors shall be tested in accordance with MIL-STD-1344, Method 1002. The following details and exceptions shall apply:

- a. Test procedure - type II.
- b. The mated connectors shall be mounted in a vertical position.
- c. Step 7a shall be performed during the last cycle.
- d. Three hours minimum after the start of step 7a, during the final cycle and while the connectors are still subjected to high humidity, the insulation resistance shall be measured when the chamber temperature reaches  $20 \pm 5$  °C ( $68 \pm 9$  °F) and condensation is observed on the connector.
- e. For qualification testing, insulation resistance readings shall be made on a minimum of 50 percent of the circuits.

4.6.18.2 Moisture resistance, extreme humidity range (solder contact connectors). Mated solder contact connectors shall be subjected to the following test. The test chamber shall consist of a box 12 inches deep by 16 inches wide by 24 inches long, capable of being sealed, and shall be constructed of materials that, in the presence of water, do not affect deterioration of the samples. An open screen tray shall be provided to support the test specimens 8 inches below the top of the box. Provisions shall be made to bring out wires for measurement purposes through vapor tight seals near the top of the box. Controls shall be provided that will cause the chamber air temperature to vary 5 °C (9 °F) once each hour for 20 days, from any temperature between 22 and 28 °C (72 and 82 °F) causing heavy condensation to form on the samples once each hour. The bottom of the test chamber shall be covered with 1/4 inch of tap water to start the test. The heat application to supply the temperature variation shall be radiant in nature and applied to the underside of the test chamber.

4.6.19 Water pressure. When specified (see 3.23.1 and 3.23.2), electrical connectors shall pass the water pressure tests of 4.16.9.1 or 4.6.19.2.

4.6.19.1 Solder contact receptacles (except class A, B, H, K, and P). The connectors shall be immersed in tap water to a depth of 6 feet for 48 hours as follows:

- a. Receptacles shall be mounted by using flange gaskets. Jam nut mounting receptacle flanges shall be sealed only with O-ring seals provided as accompanying hardware. One-half of the wall mounting receptacles shall be front mounted and the remaining half shall be back mounted. The terminal ends of the receptacles shall be external to the tank.

## MIL-DTL-5015H

b. Fifty percent of the connectors tested shall be mated, and insulation resistance of the mated immersed connectors shall be measured at the end of the 48 hour period. The other fifty percent of the connectors shall be tested unmated. Upon completion of the test, the connectors shall be removed from the tank, all external moisture removed from the connectors by shaking them at room temperature, and insulation resistance measured within one half hour after removal from the water. Receptacles, mated and unmated, shall be inspected for leakage through or around the insert and for leakage of the panel seals (see 3.23.1).

4.6.19.2 Crimp contact connectors and accessories. Crimp contact connectors or connector accessories shall be tested in accordance with 4.6.19.1 except 100 percent of the connectors shall be tested mated. Dummy connectors, duplicating crimp contact connector accessory interfacing features (see figure 1), are permitted for use in lieu of actual connectors in testing the accessories (see 3.23.2).

4.6.20 External bending moment. The receptacle shall be mounted to a rigid panel. Before mating the plug to the receptacle, a bending moment test arm shall be threaded onto the rear of the plug shell. The fixture shall be of any design which will permit the application of the load except it must not provide support for the connector shell in front of the engaged threads (see figure 9). After mating the plug and receptacle, the bending moment listed in table XVII measured from the panel shall be applied. The load shall be applied at a rate of 10 pounds per second until the required load is applied. The load shall then be held for 1 minute (see 3.24).

4.6.21 Contact engagement and separation forces. Socket contacts shall be tested in accordance with MIL-STD-1344, Method 2014. Contacts are permitted to be tested installed in the connectors (see 3.25).

4.6.22 Resistance to probe damage (size 16 only). Solder socket contacts shall be tested in accordance with MIL-STD-1344, Method 2006 (see 3.26).

4.6.23 Shell conductivity (crimp connectors). The shell to shell conductivity shall be measured in accordance with MIL-STD-1344, Method 3007. The test current used shall be  $0.100 \pm 0.01$  dc amps. The dc resistance shall not exceed the values specified in 3.27 using the voltmeter-ammeter method.

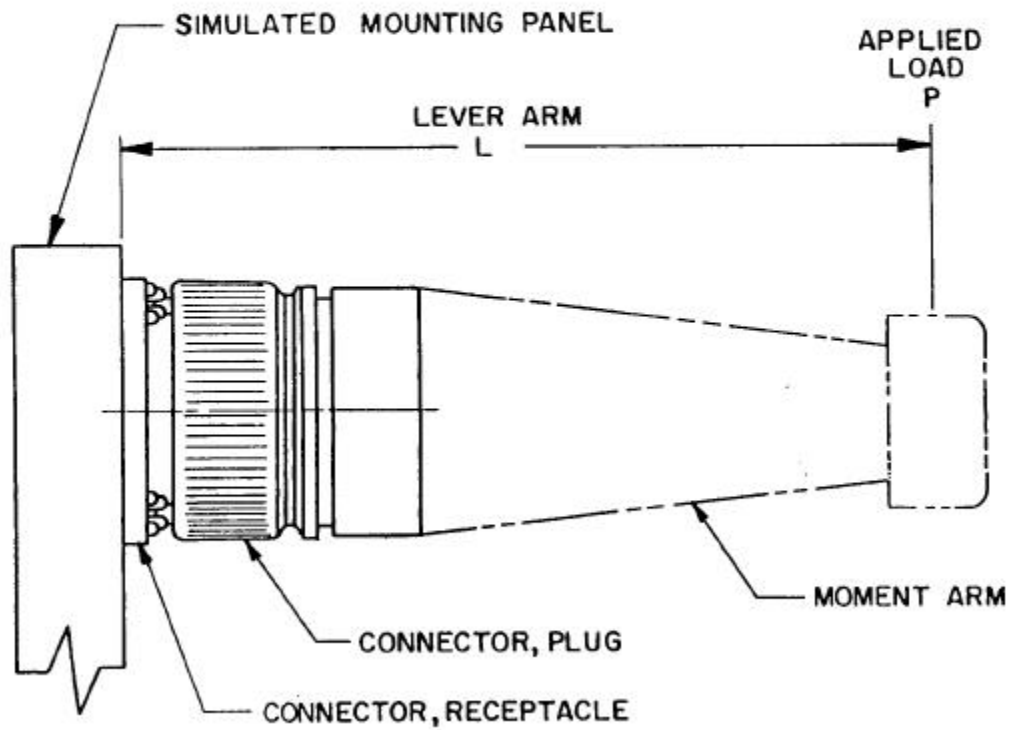

FIGURE 9. External bending moment test setup.

MIL-DTL-5015H

TABLE XVII. External bending moment.

Shell size	Bending moment (inch-pounds)
8S	60
10S, 10SL	110
12S, 12	170
14S, 14	300
16S, 16	370
18	420
20	450
22	520
24	570
28	630
32	750
36	810
40	870
44	930
48	990

4.6.24 Contact insertion and removal force (crimp contact connectors). With the grommet relaxed, a minimum of 20 percent of the contacts shall be removed and reinserted using the applicable tools specified in 3.4.1.2.1 or 3.4.1.2.2. The forces required to insert and remove the unlocked contacts shall be measured in accordance with MIL-STD-1344, Method 2012. The same contacts shall then be removed and reinserted nine more times. The contact insertion and removal forces shall be measured on the ninth cycle of half, but not less than three of the contacts selected for this test (see 3.28).

4.6.25 Altitude immersion (series III only, see 3.29). Mated connectors shall be tested in accordance with MIL-STD-1344, Method 1004. The following details shall apply:

- a. All wire ends shall be located within the chamber and exposed to the chamber atmosphere, but not submerged or sealed.

## MIL-DTL-5015H

b. At the end of the third cycle while the mated connectors are still submerged in the solution, the insulation resistance shall be measured as specified in 4.6.14.1 and the dielectric withstanding voltage test shall be performed as specified in 4.6.7.2.

c. The connector examination and value and observatory requirements of MIL-STD-1344, Method 1004 shall not apply.

### 5. PACKAGING

5.1 Packaging. For acquisition purposes, the packaging requirements shall be as specified in the contract or order (see 6.2). When actual packaging of materiel is to be performed by DoD personnel, these personnel need to contact the responsible packaging activity to ascertain requisite packaging requirements. Packaging requirements are maintained by the Inventory Control Point's packaging activity within the Military Department or Defense Agency, or within the Military Department's System Command. Packaging data retrieval is available from the managing Military Department's or Defense Agency's automated packaging files, CD-ROM products, or by contacting the responsible packaging activity.

### 6. NOTES

(This section contains information of a general or explanatory nature which may be helpful, but is not mandatory.)

6.1 Intended use. MIL-DTL-5015 is a specification that covers connectors with both military and commercial applications. Revision H to this document is a maintenance action, prior to conversion of the document to a nongovernment standard. These connectors are rated for operation within a temperature range of  $-55\text{ }^{\circ}\text{C}$  ( $-67\text{ }^{\circ}\text{F}$ ) to either  $125\text{ }^{\circ}\text{C}$  ( $257\text{ }^{\circ}\text{F}$ ),  $175\text{ }^{\circ}\text{C}$  ( $347\text{ }^{\circ}\text{F}$ ), or  $200\text{ }^{\circ}\text{C}$  ( $392\text{ }^{\circ}\text{F}$ ) depending upon the class. The upper temperature is the maximum internal hot spot temperature resulting from any combination of electrical load and ambient conditions. The various classes and types of connectors are intended for application as follows:

a. MS3100, MS3400, MS3450, and SAE-AS34001 are receptacles intended for wall or bulkhead mounting and for use with conduit or cable clamp.

b. MS3101, MS3401, MS3451, SAE-AS34011 are receptacles intended for use at the end of a cable where mounting provisions are not required.

c. MS3102, MS3402, MS3452, and SAE-AS34021 are receptacles intended for mounting on shielding boxes and equipment cases. They have no fittings and are for use with open wiring. They are nonenvironmental and are intended for use on boxes where environmental seal is achieved by some other means.

## MIL-DTL-5015H

d. MS3404, MS3412, MS3454, SAE-AS34041, SAE-AS34121, and SAE-AS34541 are receptacles intended for wall or bulkhead mounting and for use with conduit or a cable clamp.

e. MS3106, MS3406, MS3409, MS3456, and SAE-AS34061 are plugs intended for use at the end of a cable to be mated with a receptacle. MS3409 is a 45° plug intended for use at the end of a cable where space does not permit the use of a straight plug.

f. MS3107 and MS3507 are plugs intended for use at the end of a cable which may require rapid disconnect from a receptacle.

g. MS3108 and MS3408 are 90° plugs intended for use at the end of a cable where space does not permit the use of a straight plug.

h. MS3103 is a receptacle intended for use in applications where a potted seal around wires is required.

i. MS25183 is a plug intended for use in applications where a potted seal around wires is required.

j. SAE-AS34591 is a plug with a self-locking coupling nut which is designed for firewall applications.

k. All classes of the series I are either canceled or inactive for new design. For the status of specific classes see applicable MS sheets.

l. Class A connectors are solid shell connectors are intended for nonenvironmental applications.

m. Class B connectors are split shell connectors intended for nonenvironmental applications. The split shell provides greater accessibility to solder connections, as may be needed if the cable is contained in conduit.

n. Class C receptacles are intended for use on the walls and bulkheads of pressurized compartments and on the cases of pressurized equipment. They will limit air leakage to the amount specified by 3.9.1, regardless of the type and class of plug mated with them.

o. Class D connectors are intended for use where the connectors will be subjected to high-impact shock conditions beyond the capabilities of the other class connectors. These connectors have crimp contacts which are released from the front of the connector and a wire sealing range capable of sealing on naval shipboard cable. These connectors also have a specified shell conductivity.

## MIL-DTL-5015H

p. Class E connectors are inactive for new design.

q. Classes D, F, L, P, R, U, and W connectors are intended for use where the connector will be subject to heavy condensation and rapid changes in temperature or pressure, and where the connector is subject to high vibratory conditions. To ensure proper performance, a class D, F, L, P, R, U or W connector plug must always be mated to a class D, F, L, P, R, U or W receptacle. A type MS3102 (F and R), MS3402 (D, L, U, and W) MS3412 (D, L, U, and W) SAE-AS34021 (D, L, U, and W), or SAE-AS34121 (D, L, U, and W) receptacle does not provide moisture or vibration protection at its back end, and a type MS3100 (F and R), MS3400 (D, L, U, and W), or SAE-AS34001 (D, L, U, and W) should be used if such protection is desirable. Class F and R receptacles are intended for use on the walls and bulkheads of pressurized compartments and on the cases of pressurized equipment. They limit air leakage to the amount specified in 3.9.1 regardless of the type and class of plug mated to them. Potting form for class P connectors should remain with the connector after potting.

r. Class H receptacles are intended for use on hermetically sealed devices and their performance requirements are determined by the particular application. They should maintain the degree of seal required by the equipment specification and for mating with plugs conforming to the requirements of this specification.

s. Class K connectors are intended for use where it is necessary to maintain electrical continuity for a limited time even though the connector is subjected to continuous flame. To ensure such continuity, both receptacle and mated plug must be class K, and high-temperature wires must be used. If flame integrity only is desired, without the need for electrical continuity, a class K receptacle must be used but the mated plug may be of any type and class.

t. Class L connectors are intended for use where the connector will be subjected to elevated temperature 175 °C (347 °F) and where complete fluid resistance is required. These connectors have crimp contacts and are available in both front (MS34XX) and rear (MS345X) release retention systems. These connectors have a specified shell conductivity.

u. Class U connectors are intended for use where the connector will be subject to heavy condensation and rapid changes in temperature or pressure, and where the connector is subject to high vibratory conditions and elevated temperature 200 °C (392 °F). These connectors have crimp contacts and are available in both front (MS34XX) and rear (MS345X) release retention systems. In addition, these connectors provide complete fluid resistance.

v. Class W connectors are intended for general use where complete fluid resistance is required. These connectors have crimp contacts and are available in both front (MS34XX) and rear (MS345X) release retention systems.

MIL-DTL-5015H

w. Crimp contact connectors should have contacts installed in all positions when the connector is wired. Sealing plugs should be installed in the grommet holes when no wire is attached to the contact in grommet sealed connectors.

x. Counterpart solder and crimp contact connectors are intended to be intermateable. Moisture resistance capability is then reduced to that of the solder contact connectors.

y. If air leakage requirements are critical, a resilient insert receptacle or class H receptacle should be used or the connector should be potted.

6.1.1 Wire sizes to be used with contacts. It is intended that size 6 wire should be crimped or soldered to a size 4 contact because no size 6 contacts are provided and size 4 is the next larger. Except for class K connectors, satisfactory performance of connectors will be obtained if wire sizes are governed by table II. For wire diameters less than specified in table II, shrink-fit sleeving should be used over the wire. Where two or more wires are used in a solder cup, moisture sealing is not obtainable. Wires should be potted if seal is required. Electrically conductive bushings as provided for in MS3348 or SAE-AS33481 should be used in crimping sizes 10, 6, and 2 wire in contact sizes 8, 4, and 0 respectively. Only one conductor should be used in crimp removable contacts.

6.1.2 Working voltage. The maximum recommended sea level working voltage is shown in table XVIII.

TABLE XVIII. Working voltages.

Working voltages	
Service rating	(volts - rms)
Instrument	200
A	500
D	900
E	1250
B	1750
C	3000

MIL-DTL-5015H

6.2 Acquisition requirements. Acquisition documents must specify the following:

- a. Title, number, and date of this specification.
- b. Issue of the DoDISS to be cited in the solicitation, and if required, the specific issue of individual documents referenced (see 2.1).
- c. Title, number, and date of the applicable MS sheet and the complete part number.
- d. If an underplate, approved by the qualifying activity, has been used (see 3.3.2.2).
- e. If these connectors are furnished without contacts or grommet sealing plugs (see 3.4.1 and 3.4.6.1.2.1).
- f. If the insulation resistance test has been performed using simulated contacts and special techniques in lieu of actual contacts (see 4.6.14.1a).
- g. Packaging requirements (see 5.1).

6.3 Accessory hardware. Accessory hardware, such as dust covers or mounting hardware especially designed for use with the crimp type contact connectors is shown on separate drawings.

6.4 Crimp contacts. Crimp contacts may be ordered in bulk in accordance with MIL-C-39029.

6.5 Solder contacts. Solder contacts are not to be ordered or qualified separately from the connectors.

6.6 Military part or identifying number (PIN). The PIN for qualified connectors procured in accordance with this specification should be numbered as shown in the following example (see 3.30):

<u>MS3400</u>	<u>D</u>	<u>        </u>	<u>18</u>	<u>-</u>	<u>10</u>	<u>P</u>	<u>W</u>
Basic part no.	Class	Material designator	Shell size		Insert arrangement	Contact designator	Insert position
(6.6.1)	(6.6.2)	(6.6.2.1)	(6.6.3)	(6.6.4)	(6.6.5)	(6.6.6)	(6.6.7)

6.6.1 Basic part number. The basic part number is shown on the applicable MS sheet (see 3.1). Revision letters are not included.

## MIL-DTL-5015H

6.6.2 Classes. Connector classes are designated by a letter as shown in table XIX (all classes of the series I connectors are canceled or inactive for new design. See applicable MS sheet).

6.6.2.1 Material designator. Shell and coupling ring material are designated by a letter as indicated below:

S	- Stainless steel (see 3.3.6d and 3.3.6.1e).
T	- Ferrous alloy with cadmium plate for class K of MS3400 and SAE-AS34001 and MS3450 series with electrically conductive fused tin plate for class H (see 3.3.6c and 3.3.6.1d and f).
Leave blank	- Aluminum alloy (see 3.3.6a, 3.3.6.1b and g). Wrought aluminum (see 3.3.6b and 3.3.6.1b). Ferrous alloy with cadmium plate (series I, class K) (see 3.3.6c and 3.3.6.1g).
Leave blank	- Ferrous alloy with electroless nickel (class H, series II and series III, class K) (see 3.3.6c and 3.3.6.1c)

6.6.3 Shell sizes. Shell sizes are designated as follow, except for class DJ only where 10S, 12S, 14S, and 16S become 10, 13, 15, and 17 respectively and 10SL becomes 11:

8S	16	32
10S	16S	36
10SL	18	40
12	20	44
12S	22	48
14	24	
14S	28	

6.6.4 Class H terminations. For class H receptacles, the type of termination is designated by replacing the dash (-) with one of the following letters:

- C - Solder cup termination
- Y - Eyelet termination

6.6.5 Insert arrangement. The service rating, quantity, size, and position of contacts shown on the insert arrangement should be as indicated in MIL-STD-1651.

6.6.6 Contact designator.

6.6.6.1 Connectors with contacts. The following designators are used to indicate a full complement of power contacts (see 3.4.1):

## MIL-DTL-5015H

P - Pin contacts.

S - Socket contacts.

C - Feed through.

D - 16-22 pin contacts in lieu of 16-16 or where applicable, this designator indicates a full complement of 12-16 pin contacts in lieu of 12-12 (for series II only).

E - 16-22 socket contacts in lieu of 16-16 or where applicable, the designator indicates a full complement of 12-16 socket contacts in lieu of 12-12 (for series II only).

Connectors that accommodate crimp removable contacts P, S, D, and E are permitted to be ordered without contacts by adding a note on the purchase order; however, the connector part numbers and marking requirements remain unchanged.

6.6.6.2 Connectors without contacts. The following designators are used to indicate a connector less contacts. They are used only when other than power contacts are to be installed in the connector. Examples of this are shielded, thermocouple, and coaxial contacts (see 6.2).

A - Less pin contacts

B - Less socket contacts

6.6.7 Insert position. The insert position is the angular position of the insert relative to the shell key or keyway. Insert positions other than normal are indicated by the letter shown in MIL-STD-1651 (see 3.4.2.2).

6.7 Service life. Service life varies with temperature (see figure 10 and table XIX).

6.8 Coupling. MIL-C-5015 connectors use a threaded coupling except for quick disconnect MS3107 and MS3507.

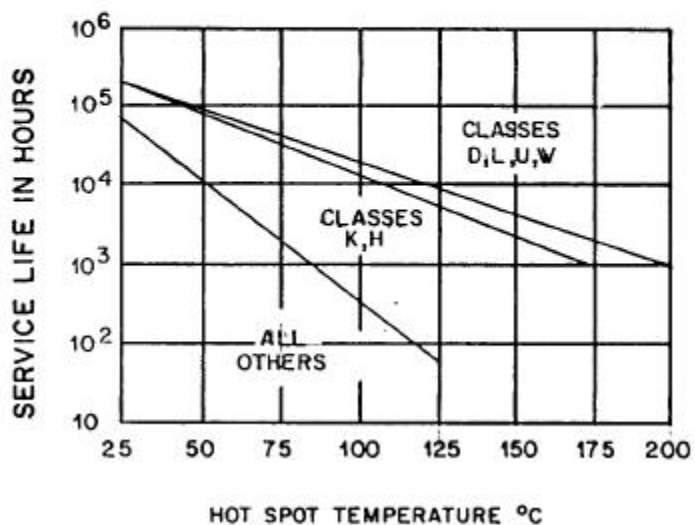
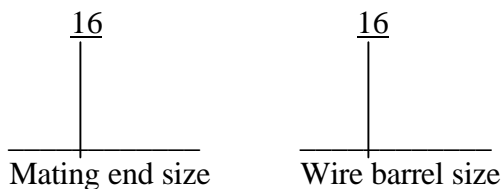

FIGURE 10. Service life vs hot spot temperature.

6.9 Contact size designation. The contact size designation for solder contacts is the mating end size. The contact size designation for crimp contacts is the mating end and wire barrel sizes as specified in MIL-C-39029.

Example of crimp contacts:



6.10 Wire range accommodations. Table II gives the wire ranges accommodated by MIL-DTL-5015 solder and crimp contact connectors.

TABLE XIX. Connector classes - physical characteristics.

Class <u>1/</u>	Feature <u>2/</u>	Solder contacts series I <u>4/</u>	Front release crimp contacts series II <u>4/</u>	Rear release crimp contacts series III <u>4/</u>	Environment resistant	Fluid resistant	Hot spot temp (°C)	Service life	Insert material	Shells and coupling rings	
										material	finish
A	Solid shell	X	---	---	---	Limited	85 125	1000 hrs 60 hrs	See 3.3.4.1	Aluminum	Cadmium olive drab
B	Split shell	X	---	---	---	Limited	85 125	1000 hrs 60 hrs	See 3.3.4.1	Aluminum	Cadmium olive drab
C	Pressurized <u>3/</u>	X	---	---	---	Limited	85 125	1000 hrs 60 hrs	See 3.3.4.1	Aluminum	Cadmium olive drab
D	High impact shock	---	X	---	X	Complete	125 175 <u>6/</u>	20 yrs 1000 hrs	Silicone	Wrought aluminum <u>7/</u> , <u>9/</u>	Cadmium olive drab
E	<u>3/</u>	X	---	---	X	Limited	85 125	1000 hrs 60 hrs	Neoprene	Aluminum	Cadmium olive drab
F	With clamp	X	---	---	X	Limited	85 125	1000 hrs 60 hrs	Neoprene	Aluminum	Cadmium olive drab
H	Hermetic seal	X	---	---	X	Complete	175	1000 hrs	Silicone	Ferrous alloy <u>7/</u> , <u>8/</u>	Electroless nickel <u>7/</u> , <u>8/</u> , <u>9/</u> , <u>10/</u>
K	Firewall	X <u>5/</u> ---	---	---	---	Limited Complete	175 <u>6/</u>	1000 hrs	Silicone	Ferrous alloy <u>7/</u> , <u>8/</u>	Cadmium, olive drab <u>7/</u> , <u>8/</u> , <u>10/</u> , <u>11/</u>

TABLE XIX. Connector classes - physical characteristics - Continued .

Class 1/	Feature 2/	Solder contacts series I 4/	Front release crimp contacts series II 4/	Rear release crimp contacts series III 4/	Environment resistant	Fluid resistant	Hot spot temp (°C)	Service life	Insert material	Shells and coupling rings	
										material	finish
L	Fluid resistant	---	X	X	X	Complete	200	1000 hrs	Silicone	Aluminum 7/, 8/	Electroless nickel 7/, 8/
P	Potting seal	X	---	---	X	Limited	85 125	1000 hrs 60 hrs	See 3.3,4.1	Aluminum	Cadmium, olive drab
R	Grommet seal without clamp	X	---	---	X	Limited	85 125	1000 hrs 60 hrs	Neoprene	Aluminum	Cadmium, olive drab
U	3/	---	X	X	X	Complete	200	1000 hrs	Silicone	Aluminum 7/, 8/	Electroless nickel 7/, 8/
W	General purpose	---	X	X	X	Complete	125 175 6/	20 yrs 1000 hrs	Silicone	Aluminum 7/	Cadmium, olive drab over nickel 7/, 9/
DJ	High impact shock with backshell connector assembly	---	X	---	X	Complete	125 175 6/	20 yrs 1000 hrs	Silicone	Wrought aluminum	Cadmium, olive drab over nickel 7/

TABLE XIX. Connector classes - physical characteristics - Continued.

NOTES:

- 1/ See applicable MS sheet for active or inactive status.
- 2/ Upgrade to 200 °C (392 °F).
- 3/ Inactive for new design, use class L.
- 4/ Only series III is authorized for Air Force new design.
- 5/ Crimp contacts.
- 6/ Hot spot temperature for inserts and seals should be 200 °C (392 °F).
- 7/ Also available in stainless steel (see 3.3.6 and 6.6.2.1).
- 8/ Also available in stainless steel; class HS, KS, LS, and US are passivated (see 3.3.6.1e and 6.6.2.1).
- 9/ Also available in stainless steel; cadmium over nickel, color black, for class DS (see 3.3.6.1d and 6.6.2.1).
- 10/ The finish of class HT connectors is electrically conductive fused tin.
- 11/ The finish of series II and III class K ferrous alloy connectors is electroless nickel.

## MIL-DTL-5015H

6.11 Interchangeability of MS and AN marked connectors. Connectors covered by the MS standards and AN aeronautical standard drawings and part numbers as described in 6.6 are interchangeable. Connectors bearing an MS part number may replace an AN marked connector of any modification marking, if all other identifying symbols are identical.

6.12 Interchangeability with pin contacts. Connectors with pin contacts bearing MS part numbers are interchangeable with connectors bearing AN part numbers, if all other portions of the part number are identical. The presence or absence of a modification letter in either type or marking has no bearing on the interchangeability of pin contact connectors.

6.13 Interchangeability with socket contacts. Connectors containing socket contacts and marked with an MS part number are interchangeable with connectors marked with an AN or MS part number with the same remaining identification symbol regardless of the presence of the modification letter. Connectors marked with AN part number but bearing no modification letter are not for use as replacement of parts for AN connectors with the modification letter or with MS marked connectors unless it can be established and certified that such parts are capable of passing applicable resistance to probe damage (see 4.6.22).

6.14 Qualification. With respect to products requiring qualification, awards will be made only for products which are, at the time of award of the contract, qualified for inclusion in Qualified Products List QPL No. 5015 whether or not such products have actually been so listed by that date. The attention of the contractors is called to these requirements, and manufacturers are urged to arrange to have the products that they propose to offer to the Federal Government tested for qualification in order that they may be eligible to be awarded contracts or purchase orders for the products covered by this specification. Information pertaining to qualification of products may be obtained from the Naval Air Warfare Center Aircraft Division, Code 4.4.4, Suite 5, 48142 Shaw Road, Unit 5, Patuxant River, MD 20670.

6.14.1 Provisions Governing Qualification. Copies of "Provisions Governing Qualification" are available from the DoDSSP Standardization Documents Order Desk, 700 Robbins Avenue, Building 4D, Philadelphia, PA 19111-5094.

6.15 Screw threads. Guidance regarding UNS class 2A or 2B screw threads and the use of ring and plug gages after plating is given in Federal handbook H-28 (see 3.4.3).

6.16 Contact materials. Contacts for class H connectors are permitted to be made of ferrous alloy. Thermocouple contacts are permitted to be magnetic (see 3.3.3.1)

6.17 Dissimilar metals. Guidance concerning the use of dissimilar metals is given in MIL-HDBK-454, guideline 16 (see 3.3.1).

MIL-DTL-5015H

6.18 Subject term (key word) listing.

Cable  
Cadmium  
Contact  
Crimp contact connector  
Grommet sealing plug  
Insertion and removal tools  
Insert arrangement  
Solder contact connector  
Thermal shock  
Wire

6.19 Changes from previous issue. Marginal notations are not used in this revision to identify changes with respect to the previous issue due to the extent of the changes.

CONCLUDING MATERIAL

Custodians:

Army - CR  
Navy - AS  
Air Force - 85

Preparing activity:

Navy - AS  
  
(Project 5935-4064)

Review activities:

Army – AR, MI  
Navy - EC  
Air Force - 17, 99  
DLA - CC  
NASA – NA

## STANDARDIZATION DOCUMENT IMPROVEMENT PROPOSAL

### INSTRUCTIONS

1. The preparing activity must complete blocks 1, 2, 3, and 8. In block 1, both the document number and revision letter should be given.
2. The submitter of this form must complete blocks 4, 5, 6, and 7, and send to preparing activity.
3. The preparing activity must provide a reply within 30 days from receipt of the form.

NOTE: This form may not be used to request copies of documents, nor to request waivers, or clarification of requirements on current contracts. Comments submitted on this form do not constitute or imply authorization to waive any portion of the referenced document(s) or to amend contractual requirements.

<b>I RECOMMEND A CHANGE:</b>	<b>1. DOCUMENT NUMBER</b> MIL-DTL-5015H	<b>2. DOCUMENT DATE (YYYYMMDD)</b> 20000518
<b>3. DOCUMENT TITLE</b> CONNECTORS, ELECTRICAL, CIRCULAR THREADED, AN TYPE, GENERAL SPECIFICATION FOR		
<b>4. NATURE OF CHANGE</b> ( <i>Identify paragraph number and include proposed rewrite, if possible. Attach extra sheets as needed.</i> )		
<b>5. REASON FOR RECOMMENDATION</b>		
<b>6. SUBMITTER</b>		
a. NAME ( <i>Last, First, Middle Initial</i> )	b. ORGANIZATION	
c. ADDRESS ( <i>Include ZIP Code</i> )	d. TELEPHONE ( <i>Include Area Code</i> ) (1) Commercial  (2) DSN ( <i>If applicable</i> )	<b>7. DATE SUBMITTED</b> (YYYYMMDD)
<b>8. PREPARING ACTIVITY</b>		
a. NAME COMMANDER NAVAL AIR WARFARE CENTER AIRCRAFT DIVISION	b. TELEPHONE ( <i>Include Area Code</i> ) (1) Commercial (732) 323-2947 (2) DSN 624-2947	
c. ADDRESS ( <i>Include ZIP Code</i> ) CODE 414100B120-3 HIGHWAY 547 LAKEHURST, NJ 08733-5100	<b>IF YOU DO NOT RECEIVE A REPLY WITHIN 45 DAYS, CONTACT:</b> Defense Standardization Program Office (DLSC-LM) 8725 John J. Kingman Road, Suite 2533 Fort Belvoir, Virginia 22060-6221 Telephone (703) 767-6888 DSN 427-6888	