

INCH-POUND

MIL-PRF-71185 (AR)

30 July 1999

## PERFORMANCE SPECIFICATION

### DYNAMIC REFERENCE UNIT HYBRID (DRUH)

This specification is approved for use by the U.S. Army Armament Research, Development and Engineering Center, and is available for use by all Departments and Agencies of the Department of Defense.

#### 1. SCOPE

1.1 Scope. This specification covers the Dynamic Reference Unit Hybrid (DRUH). The DRUH is the major line replaceable unit (LRU) of the Modular Azimuth Position System (MAPS) Hybrid integrated survey system.

#### 2. APPLICABLE DOCUMENTS

2.1 General. The documents listed in this section are specified in sections 3 and 4 of this specification. This section does not include documents cited in other sections of this specification or recommended for additional information or as examples. While every effort has been made to ensure the completeness of this list, document users are cautioned that they must meet all requirements documents cited in sections 3 and 4 of this specification, whether or not they are listed.

Beneficial comments (recommendations, additions, deletions) and any pertinent data which may be of use in improving this document, should be addressed to: Commander, U.S. Army ARDEC, ATTN: AMSTA-AR-QAW-E, Picatinny Arsenal, New Jersey 07806-5000 by using the Standardization Document Improvement Proposal (DD Form 1426) appearing at the end of this document or by letter.

AMSC N/A

FSC 1220

**DISTRIBUTION STATEMENT A.** Approved for public release; distribution is unlimited.

2.2 Government documents.

2.2.1 Specifications, standards, and handbooks. The following specifications, standards, and handbooks form a part of this document to the extent specified herein. Unless otherwise specified, the issues of these documents are those listed in the issue of the Department of Defense Index of Specifications and Standards (DODISS) and supplement thereto, cited in the solicitation (see 6.2).

SPECIFICATIONS

DEPARTMENT OF DEFENSE

MS27468 Connector, Receptacle, Electrical Jam Nut Mounting, Crimp Type, Bayonet Coupling Series I

STANDARDS

DEPARTMENT OF DEFENSE

MIL-STD-461 Electromagnetic Emission and Susceptibility Requirements for the Control of Electromagnetic Interference

MIL-STD-462 Electromagnetic Interference Characteristics, Measurements of

MIL-STD-810 Environmental Test Methods and Engineering Guidelines

MIL-STD-1275 Characteristics of 28 Volt DC Electrical Systems in Military Vehicles

MIL-STD-1553 Digital Time Division Command/Response Multiplex Data Bus

HANDBOOK

DEPARTMENT OF DEFENSE

MIL-HDBK-781 Reliability Test Methods, Plans and Environments for Engineering Development, Qualification, and Production

(Unless otherwise indicated, copies of the above specifications, standards, and handbooks are available from the Standardization Document Order Desk, Bldg. 4D, 700 Robbins Avenue, Philadelphia, PA 19111-5094.)

2.2.2 Other Government documents, drawings, and publications. The following other Government documents, drawings, and publications form a part of this specification to the extent specified herein. Unless otherwise specified, the issues are those cited herein.

PUBLICATIONS

ICD-GPS-153      GPS User Equipment Interface Control Document for the RS-232/RS-422 Interface of DoD Standard GPS UE Radio Receivers

SS-M/V-500      Specification for NAVSTAR Global Positioning System (GPS) Precision Lightweight GPS Receiver (PLGR)

(ICD-GPS-153 and SS-M/V-500 may be obtained from Global Positioning System (GPS) Joint Program Office (JPO), SMC/CZ, 2435 Vela Way, Suite 1613, Los Angeles Air Force Base, El Segundo, CA 90245-5500.)

Nuclear Survivability Criteria for the Modular Azimuth Position System (MAPS), equipment survivability category: man in truck or signal shelter, equipment exposed, 20 DEC 1984

(U. S. Army Nuclear and Chemical Agency, ATTN: MONA-ZB, 7150 Heller Loop, Suite 101, Springfield, VA 22150-3198.)

FM 3-5            NBC Decontamination

(Commandant, U.S. Army Chemical School, ATTN: ATZN-CM-FNB, Fort McClellan, AL 36205-5020.)

2.3 Non-Government publications. The following documents form a part of this specification to the extent specified herein. Unless otherwise specified, the issues of the documents which are DoD adopted are those listed in the issues of the DODISS cited in the solicitation. Unless otherwise specified, the issues of documents not listed in the DODISS are the issued of documents cited in the solicitation (see 6.2).

ELECTRONICS INDUSTRIES ALLIANCE (EIA)

EIA RS-422-B      Electrical Characteristics of Balanced Voltage Digital Interface Circuits

(Application for copies should be addressed to Electronic Industries Alliance, 2500 Wilson Boulevard, Arlington, VA 22201-3834.)

2.4 Order of precedence. In the event of a conflict between the text of this specification and the references cited herein, the text of this specification would take precedence. Nothing in this specification, however, supersedes applicable laws and regulations unless a specific exemption has been obtained.

### 3. REQUIREMENTS

3.1 Design verification. When specified in the contract (see 6.2), a sample of the DRUH shall be subjected to design verification in accordance with 4.5.

3.2 First article. When specified in the contract or purchase order (see 6.2), a sample shall be subjected to first article inspection in accordance with 4.6.

3.3 Interface and interoperability requirements. The DRUH shall be a self-contained surveying system for use in U.S. Army survey, weapon and target acquisition systems, and shall be capable of electronically exchanging data with a host, vehicle motion sensor, and external GPS Receiver.

3.3.1 Configuration tailoring. The DRUH shall tailor its operation and relate input and output parameters to specific host configurations using fixed and changeable configuration data in accordance with Appendix C.

3.3.2 Alternate functionality. The DRUH shall permit selection between DRU Hybrid functionality, as specified herein, and functionality of an alternate software package (see 3.3.13.6.3 and 6.2.) Both software packages shall reside within the DRUH.

3.3.3 Reprogramming capability. The DRUH and alternate survey software programs, fixed configuration data and datum data shall be separately reprogrammable without removal of the DRUH covers. An external programming device may be used. If the DRUH software is partitioned, that software partition which compensates raw sensor data is not required to be reprogrammable.

3.3.4 Host/DRUH data exchange. The DRUH shall receive commands and data from the host and send data to the host over Host RS-422 and MIL-STD-1553 data buses as specified in Appendices A and D. Command and message formats and specific data elements shall be as specified in the detailed command and message descriptions given in Appendices A and D. In this document, Host RS-422 bus commands and messages generally are specified. Unless otherwise specified, the functional requirements also apply to the equivalent MIL-STD-1553 bus commands and messages.

3.3.4.1 DRUH status reporting. The DRUH shall indicate its operational status as specified in Appendix B. Unless otherwise specified, the requirements to set and reset status indications are the same regardless of the data bus or output message.

3.3.4.2 DRUH alert reporting. The DRUH shall indicate alert conditions, including illegal operations and invalid input data, as specified in Appendix B. Unless otherwise specified, the requirements to set and reset alert indications are the same regardless of the data bus or output message. In this document, a requirement to set or reset an alert indication also infers the requirement to appropriately set and reset STATUS DATA S2/1 (DRUH Alert) and S5/3 (Change in ALERT DATA).

3.3.4.3 Failure reporting. The DRUH shall indicate failure conditions to the host as specified in Appendix B. The requirements to set and reset failure indications are the same regardless of the data bus or output message. In this document, a requirement to set or reset a failure indication also infers the requirement to appropriately set and reset STATUS DATA S2/5 (BIT Malfunction Detected) and S5/2 (Change in BIT DATA).

3.3.4.4 Command checking. Except for the command assigned to suppliers, the DRUH shall not accept any commands, data, or software changes except those specified herein. ALERT DATA D5/0 (Undefined Command Received) shall be set in response to any command containing an undefined command code, incorrect number of bytes, or transmission error. If the defective command was received on a Host RS-422 data bus, a STATUS DATA message shall be returned.

3.3.4.5 Data entry checking. Commands containing any data outside the allowable range(s), specified in the command description, shall be rejected. ALERT DATA D5/2 (Invalid Data Received) shall be set in response to any command containing out of range data. Additional alert indications shall be set for out of range position parameters as listed in Table I.

Table I - Out of range alert indications.

PARAMETER	ALERT DATA Byte/Bit
Easting or Northing	D4/3 (Horizontal Position Update Rejected)
Altitude	D4/4 (Altitude Update Rejected)
Latitude or Longitude	D4/3 (Horizontal Position Update Rejected)
Datum ID	D1/5 (Datum Update Rejected)

Specific out of range data values that indicate parameters are not to be updated (no change values) (3.3.7.5.3) shall not result in command rejection or alert indications.

3.3.5 Positioning. At any time after communication with the host has been established, the DRUH shall provide current estimates of position, velocity, and estimated position accuracy, when requested. The DRUH shall continuously determine position as it is moved. STATUS DATA S1/4 (OK To Move) shall be set after position has been initialized and position accuracy requirements for Interrupted Static Align (3.6.2) are met.

3.3.5.1 Motion detection. The DRUH shall set STATUS DATA S3/2 (DRUH In Motion) when the host is moving. Within 5 seconds after the host has stopped, the DRUH shall reset STATUS DATA S3/2. Externally observable responses, which are dependent on motion detection, shall be consistent with the current state of STATUS DATA S3/2.

When the host is nominally stationary, motion from rotating/aiming the pointing device, crew and cargo movement, wind buffeting, engine operation, and weapon recoil shall not cause STATUS DATA S3/2 to set. While the host is nominally stationary more than 60 seconds, position values output by the DRUH shall not change except to reflect position initialization or host position updates.

3.3.5.2 Position reference. Positions shall be referenced to the datum stored at the last shutdown or last accepted in an ACCEPT POSITION or ACCEPT GEODETIC DATA command in accordance with Appendix G.

Positions shall be referenced to the vehicle offset point (Orientation 1) or pointing device offset point (Orientation 2) specified in configuration data.

Grid positions shall be for the grid (UTM or BNG) designated in the data stored at the last shutdown or in the last accepted ACCEPT POSITION or ACCEPT GEODETIC DATA command.

UTM positions shall be for the normal or extended UTM zone as designated in the data stored at the last shutdown or in the last accepted ACCEPT POSITION command.

The DRUH shall have the capability to: reference positions to GPS (absolute) or to local survey control (relative); and switch between output of absolute or relative positions at any time.

When acceptable GPS data are available, the DRUH shall determine the relative offsets between GPS and host entered positions when specified in the last accepted ACCEPT POSITION or ACCEPT GEODETIC DATA command. STATUS DATA S2/0 (Relative Offsets Determined) shall be set when relative offsets have been determined. The

current relative offsets and state of STATUS DATA S2/0 shall be stored at shutdown. At power-on, relative offsets shall be initialized in accordance with 3.3.8.1 j. Relative offsets shall be zeroed and STATUS DATA S2/0 reset if the datum is changed and new relative offsets are not determined.

After power-on, the DRUH shall: output absolute or relative positions according to the state of the Initialize Relative Output flag (CONFIG D28/2); and set the Relative Offsets Applied flag in output messages to the corresponding state.

3.3.6 Orientation. Orientation reference frames, parameters and angular rates shall be as defined in 6.3.1, 6.3.2 and 6.3.3, respectively.

At any time after communication with the host has been established, the DRUH shall provide current estimates of vehicle and pointing device azimuth, pitch, roll or cant, pointing device angular rates, and estimated azimuth accuracy, when requested.

The DRUH shall output geodetic or grid azimuth and roll or cant as specified in configuration data.

Grid azimuths shall be for the grid (UTM or BNG) designated in the data stored at the last shutdown or in the last accepted ACCEPT POSITION or ACCEPT GEODETIC DATA command.

UTM grid azimuths shall be for the normal or extended UTM zone as designated in the data stored at the last shutdown or in the last accepted ACCEPT POSITION command.

Orientation attitudes and angular rates shall be related to the host pointing device and vehicle coordinate frames, as defined by configuration data, boresight angles, orientation (1 or 2), and travel lock state.

After STATUS DATA S3/1 (Orientation Attitude Data Valid) is set, the DRUH shall provide orientation and angular rate data to the specified accuracy requirements, when requested.

3.3.6.1 Orientation references. The DRUH shall reference position, orientation and angular rate data to host specific primary (Orientation 1) and secondary (Orientation 2) orientations.

- a. Orientation 1 shall be defined by: a DRUH Coordinate Frame code, vehicle boresight angles, pointing device boresight angles, and position offset distances.

- b. Orientation 2 shall be defined by: a DRUH Coordinate Frame code, pointing device boresight angles, and position offset distances.

Transition between Orientation 1 and Orientation 2 shall be triggered by one of the following conditions as specified by configuration data flags:

- a. Current orientation attitudes crossing predetermined vehicle specific limits;
- b. Transition of the travel lock discrete signal; or
- c. Receipt of an IN TRAVEL LOCK or OUT OF TRAVEL LOCK command.

STATUS DATA S3/7 (Orientation Transition In Process) shall be set while switching between Orientations 1 and 2. STATUS DATA S3/7 shall be reset when orientation transition is complete and position, velocity, orientation and angular rate data are referenced to the new orientation. The time to switch orientations and provide data referenced to the new orientation shall not exceed 3 seconds. STATUS DATA S4/7 (DRUH In Orientation 2) shall be set while in Orientation 2 and reset while in Orientation 1.

**Note:** STATUS DATA S4/7, position data, velocity data, attitude data and attitude rate data may not be referenced to either orientation when STATUS DATA S3/7 is set.

3.3.7 Aiding. The DRUH shall not use externally referenced aiding data except from the following:

- a. An external GPS receiver, meeting the requirements of SS-M/V-500, when the GPS Installed flag (CFIG D27/7) is set.
- b. An external Vehicle Motion Sensor (VMS) (see 3.3.13.4.6) when the Odometer Installed flag (CFIG D29/0) is set.
- c. Zero-velocity updates (ZUPTs) while stopped.
- d. Host position updates while stopped.

3.3.7.1 Aiding selection. The DRUH shall allow the host to enable and inhibit each aiding source. The DRUH shall use an aiding source only if: the external aiding source is specified in configuration data; and the external aiding source and communications link are operational; and the aiding source is enabled; and aiding data from the source meets the source data acceptance criteria. Unless otherwise specified:

- a. The DRUH shall not require VMS data or stops when useable GPS data are available.
- b. When useable VMS data are available and ZUPTs are enabled, the DRUH shall not require a stop before the time since the last ZUPT or useable GPS data set, whichever occurred last, exceeds the Odometer Mode ZUPT Interval, specified in configuration data.
- c. When ZUPTs are enabled, the DRUH shall not require a stop before the time since the last ZUPT or usable GPS data set, whichever occurred last, exceeds the Exclusive ZUPT Mode Interval, specified in configuration data.
- d. Host position updates may be required only when: an acceptable initial position isn't available from another source; or travel time since the last completed ZUPT or usable GPS data set, whichever occurred last, has exceeded 150 percent of the applicable ZUPT interval; or after completion of Air or Marine Transport and useable GPS data are not available.

3.3.7.2 GPS aiding. The DRUH may use GPS aiding when: the GPS Installed flag (CONFIG D27/7) is set; and the GPS receiver, antenna and communication link pass BIT; and GPS aiding is enabled; and current GPS data meet the acceptance criteria. The DRUH shall not use GPS aiding when: the GPS Installed flag (CONFIG D27/7) is reset; or the GPS receiver or antenna or communications link fail BIT; or GPS aiding is inhibited; or current GPS data do not meet the acceptance criteria.

3.3.7.2.1 GPS data acceptance criteria. The DRUH may use current valid GPS data sets having an Estimated Position Error (EPE)  $\leq$  the GPS Good Value specified in configuration data. The DRUH shall not use invalid GPS data sets, old (stale) GPS data sets or current GPS data sets having an EPE  $>$  the GPS Poor Value specified in configuration data.

If a USE DEGRADED GPS DATA command is accepted, the DRUH shall set STATUS DATA S6/6 (Degraded GPS Enabled) and may use valid GPS data sets having an EPE  $\leq$  the GPS Poor Value. When STATUS DATA S6/6 is set and a valid GPS data set with EPE  $\leq$  the GPS EPE Good Value becomes available, the acceptance criteria shall become the GPS Good Value and STATUS DATA S6/6 shall be reset.

The DRUH shall not use GPS position or velocity data for initialization or aiding when a GPS Antenna Fault is indicated (3.3.9.4.3.3).

GPS position and velocity data are valid if data in the current GPS Message 3 (Time Mark Data) meet all criteria listed in Table II.

Table II - GPS position and velocity validity criteria.

TIME MARK DATA WORD	BIT(s)	POSITION VALID	VELOCITY VALID
55 (Figure of Merit)	15/14 (State 5/State 3 Operation)	0/1 or 1/0	1/0
55 (Figure of Merit)	13 (< 4 meas. incorp.)	0	0
55 (Figure of Merit)	10 (Nav data not valid)	0	0
55 (Figure of Merit)	09 (RPU Failure)	0	0
45 (Chan. 1 Status A)	12 (Code Type)	0	0
47 (Chan. 2 Status A)	12 (Code Type)	0	0
49 (Chan. 3 Status A)	12 (Code Type)	0	0
51 (Chan. 4 Status A)	12 (Code Type)	0	0

3.3.7.3 VMS aiding. The DRUH may use VMS aiding when: the Odometer Installed flag (CFG D29/0) is set; and the VMS passes BIT; and VMS aiding is enabled. The DRUH shall not use VMS aiding when: the Odometer Installed flag (CFG D29/0) is reset; or the VMS failed BIT; or VMS aiding is inhibited. The set state of STATUS DATA S2/4 (Pointing Device In Travel Lock) indicates the host has established a nominally fixed relationship between the DRUH and the host direction of travel.

3.3.7.3.1 Faulty VMS aiding data. When a VMS malfunction or a significant amount of erroneous VMS data is detected, the DRUH shall:

- a. Inhibit VMS aiding.
- b. Set BIT DATA D2/1 (VMS Fail) and D2/0 (VMS Drive Fail).
- c. Perform VMS hardware BIT. The DRUH may wait until the host stops to perform VMS hardware BIT.
  - (1) If the VMS passes hardware BIT, BIT DATA D2/1 (VMS Fail) and D2/0 (VMS Drive Fail) shall remain set.
  - (2) If the VMS fails hardware BIT, BIT DATA D2/1 (VMS Fail) shall remain set and BIT D2/0 (VMS Drive Fail) shall be reset.

3.3.7.4 ZUPT aiding. The DRUH may utilize zero-velocity updates (ZUPTs) when STATUS DATA S3/2 (DRUH In Motion) and S3/4 (ZUPTs Inhibited) are reset. ZUPTs shall be initiated

automatically. The DRUH shall not require stopping for more than 30 seconds to complete a ZUPT during Survey, interrupted Static Align, or Dynamic Align. A ZUPT shall be terminated or interrupted when STATUS DATA S3/2 (DRUH In Motion) is set or when motion would result in excessive position or attitude error. Termination or interruption of a ZUPT shall not degrade DRUH performance.

3.3.7.4.1 Valid unscheduled ZUPT requests. When useable GPS data are not available, the DRUH may request ZUPTs, no more frequently than the Exclusive ZUPT Mode Interval, when severe road/terrain conditions, such as soft sand, mud, snow, or ice, result in excessive erroneous VMS data. The DRUH may request a ZUPT when gyro parameters must be adjusted because of severe thermal rates. Neither of these conditions shall be considered relief from 3.5.2.3 and 3.5.9.

3.3.7.5 Host position updates. The DRUH shall accept position updates via ACCEPT POSITION and ACCEPT GEODETIC DATA commands containing data meeting acceptance criteria. Position updates shall be relative to the WGS-84 datum, WGS-72 datum, preprogrammed local datums or user defined datums. Grid coordinates shall be relative to the UTM grid or British National Grid (BNG).

Position updates include horizontal position or altitude updates (3.3.7.5.7), use of the relative offset flags (3.3.7.5.7.4), datum updates (3.3.7.5.8) and grid updates (3.3.7.5.9).

3.3.7.5.1 Grid coordinate update. If acceptance criteria have been met, the DRUH shall accept updates of any combination of the following parameters in an ACCEPT POSITION command: Datum; Grid; Extended Zone; Horizontal Position (Northing, Easting, Hemisphere & Zone); and Altitude. Partial updates of horizontal position shall not be accepted.

3.3.7.5.2 Geodetic coordinate update. If acceptance criteria have been met, the DRUH shall accept updates of any combination of the following parameters in an ACCEPT GEODETIC DATA command: Datum; Horizontal Position (Latitude and Longitude); and Altitude. Partial updates of horizontal position shall not be accepted.

When an ACCEPT GEODETIC DATA command is used to initialize/update the DRUH, UTM grid positions and grid azimuths shall be output in the normal zone until such time that an ACCEPT POSITION command specifying extended zone output has been accepted.

3.3.7.5.3 Parameter no-change values. The DRUH shall accept the parameter values listed in Table III which indicate a parameter grouping is not to be updated.

Table III - No update parameter values.

PARAMETER GROUP	VALUE
<b>Horizontal Position</b>	
Hemisphere/Zone, and	0
Easting, and	1,048,575
Northing	16,777,215
or	
Latitude, and	91° 0'
Longitude	181° 0'
<b>Altitude</b>	16,383
<b>Datum</b>	6 ASCII spaces (20 hex)
<b>Grid</b>	15
<b>Extended Zone</b>	0

3.3.7.5.4 Position update characteristics. The DRUH shall not accept an update if any parameter is rejected. The DRUH shall not accept partial no-change value updates of horizontal position. The DRUH shall set ALERT DATA D5/7 (Invalid Update Request) if an invalid grouping is received. The DRUH may reject an update request and set ALERT DATA D5/7 (Invalid Update Request) if it is received while STATUS DATA S2/6 (Datum or Position Update In Progress) is set.

The DRUH shall accept UTM coordinate updates in terms of the normal zone or extended zone regardless of the designation of the zone/extended zone for output messages.

3.3.7.5.5 Position update reference. Positions input to the DRUH will be for the applicable vehicle (Orientation 1) or pointing device (Orientation 2) offset point. The DRUH shall relate the offset point position to the DRUH location.

3.3.7.5.6 Position update duration. When STATUS DATA S3/1 (Orientation Attitude Data Valid) is set, position updates shall be completed within 5 seconds after receipt of the update command. When STATUS DATA S3/1 is reset, position updates shall be completed within 60 seconds after receipt of the update command.

3.3.7.5.7 Horizontal position and altitude updates. The DRUH shall accept host updates of the horizontal and altitude coordinates, while the host is stationary, upon receipt of an ACCEPT POSITION or ACCEPT GEODETIC DATA command. If STATUS DATA S3/2 (DRUH In Motion) is in the set state when the update command

is received, the position update shall be rejected and ALERT DATA D3/5 (Motion During Update request) shall be set.

**NOTE:** Change in position output by the DRUH, during a position update, may reflect the update process, not host motion.

3.3.7.5.7.1 Acceptance criteria, GPS data not available. If valid GPS data are not available, the DRUH shall accept and use position parameters, input during Static Align via an ACCEPT POSITION or ACCEPT GEODETIC DATA command, meeting the allowable range limits.

While in Accelerated Align or Survey and valid GPS data are not available, the DRUH shall compare position coordinates, input via an ACCEPT POSITION or ACCEPT GEODETIC DATA command, to the present internal estimate of DRUH position. The DRUH shall accept or reject the update based on the absolute values of position differences as specified in Table IV. If any parameter is rejected, the entire update shall be rejected and the listed ALERT DATA bit(s) shall be set.

Table IV. Position acceptance criteria - no GPS.

<b>ABSOLUTE VALUE POSITION DIFFERENCE (meters)</b>	<b>ACCEPT REJECT</b>	<b>SET ALERT DATA</b>
<b>Horizontal Position</b>		
$\Delta Pos \leq (3 * DRUH\_EHE + 10)$	accept	
$(3 * DRUH\_EHE + 10) < \Delta Pos \leq (12 * DRUH\_EHE + 150)$	reject	D4/0 (Horizontal Position Update Excessive)
$\Delta Pos > (12 * DRUH\_EHE + 150)$	reject	D4/3 (Horizontal Position Update Rejected)
<b>Altitude</b>		
$\Delta Alt \leq (3 * DRUH\_EVE + 5)$	accept	
$(3 * DRUH\_EVE + 5) < \Delta Alt \leq (12 * DRUH\_EVE + 50)$	reject	D4/1 (Altitude Update Excessive)
$\Delta Alt > (12 * DRUH\_EVE + 50)$	reject	D4/4 (Altitude Update Rejected)

3.3.7.5.7.2 Acceptance criteria, valid GPS data available. When the DRUH is in Align or Survey and valid GPS data are available, the DRUH shall compare position coordinates in an ACCEPT POSITION or ACCEPT GEODETIC DATA command to the current GPS position, offset to a common reference point. The DRUH shall accept or reject the update based on the absolute values of position differences as specified in Table V. If any parameter is rejected, the entire update shall be rejected and the listed ALERT DATA bit(s) shall be set.

Table V. Position acceptance criteria - GPS.

<b>ABSOLUTE VALUE POSITION DIFFERENCE (meters)</b>	<b>ACCEPT REJECT</b>	<b>SET ALERT DATA</b>
<b>Horizontal Position</b>		
$\Delta\text{Pos} \leq 3 \cdot (\text{GPS\_EHE}^2 + 900)^{1/2}$	accept	
$3 \cdot (\text{GPS\_EHE}^2 + 900)^{1/2} < \Delta\text{Pos} \leq 12 \cdot (\text{GPS\_EHE}^2 + 900)^{1/2}$	reject	D4/0 (Horizontal Position Update Excessive) & D4/2 (GPS Position and Update Disagree)
$\Delta\text{Pos} > 12 \cdot (\text{GPS\_EHE}^2 + 900)^{1/2}$	reject	D4/3 (Horizontal Position Update Rejected) & D4/2 (GPS Position and Update Disagree)
<b>Altitude</b>		
$\Delta\text{Alt} \leq 3 \cdot (\text{GPS\_EVE}^2 + 100)^{1/2}$	accept	
$3 \cdot (\text{GPS\_EVE}^2 + 100)^{1/2} < \Delta\text{Alt} \leq 12 \cdot (\text{GPS\_EVE}^2 + 100)^{1/2}$	reject	D4/1 (Altitude Update Excessive) & D4/2 (GPS Position & Update Disagree)
$\Delta\text{Alt} > 12 \cdot (\text{GPS\_EVE}^2 + 100)^{1/2}$	reject	D4/4 (Altitude Update Rejected) & D4/2 (GPS Position & Update Disagree)

3.3.7.5.7.3 Update after rejection. When an update has been rejected, the data shall be retained for comparison if the data are reentered. If: the reentered data are the same; and the host has remained stationary; and ALERT DATA D4/3 (Horizontal Position Update Rejected) or D4/4 (Altitude Update Rejected) was not previously set, the reentered update shall be accepted. Otherwise, the data shall be tested in accordance with 3.3.7.5.7.1 or 3.3.7.5.7.2 as if the update was received for the first time.

3.3.7.5.7.4 Determine relative offsets. The DRUH shall perform as follows when valid horizontal position or altitude updates are received:

- a. If the Determine Relative Offsets flag = 1 and valid GPS data are not available, the position update shall be rejected and ALERT DATA D1/3 (Update Rejected GPS Invalid) shall be set. In this case, rejection based on error criteria shall not be reported.
- b. If the Determine Relative Offsets flag = 1, valid GPS data are available, and the update position meets the acceptance criteria (3.3.7.5.7.2): position shall be updated, new relative offsets shall be determined, STATUS DATA S2/0 (Relative Offsets Determined) shall be set, and the new

relative offsets applied according to the state of the Apply Relative Offsets flag.

- c. If the Determine Relative Offsets flag = 0, the update position meets the acceptance criteria (3.3.7.5.7.1 or 3.3.7.5.7.2), and the position update input datum is the same as the current datum: position shall be updated and the current relative offsets and state of STATUS DATA S2/0 (Relative Offsets Determined) shall be retained.
- d. If the Determine Relative Offsets flag = 0, the update position meets the acceptance criteria (3.3.7.5.7.1 or 3.3.7.5.7.2), and the position update input datum differs from the current datum: position shall be updated, the relative offsets shall be zeroed, and STATUS DATA S2/0 (Relative Offsets Determined) shall be reset.

If the position update is rejected, the current relative offsets and the current state of STATUS DATA S2/0 (Relative Offsets Determined) shall be retained regardless of the state of the Determine Relative Offsets flag.

Determination of Relative Offsets shall be independent of whether GPS aiding is enabled or inhibited.

3.3.7.5.8 Datum updates. The DRUH shall accept and then output coordinates referenced to the datum specified in a valid ACCEPT POSITION DATA or ACCEPT GEODETIC DATA command. If the datum and horizontal position are updated in the same command, the coordinates in the command shall be considered to be on the datum specified in the command. The DRUH shall accept an ACCEPT POSITION DATA or ACCEPT GEODETIC DATA command containing valid data, in which all items except Datum ID Code are no-change values, whether stationary or moving.

3.3.7.5.9 Grid updates. The DRUH shall accept and output coordinates with respect to the grid (BNG or UTM) as defined in a valid ACCEPT POSITION or ACCEPT GEODETIC DATA command.

The DRUH shall accept an ACCEPT POSITION DATA or ACCEPT GEODETIC DATA command containing valid data, in which all items except Host Grid are no-change codes, whether stationary or moving.

3.3.8 Functional states. The DRUH shall support the following functional states: Initialization, Accelerated Align, Static Align, Interrupted Static Align, Dynamic Align, Survey, Air Transport, Marine Transport, Restart Required and Shutdown Complete. As a minimum, the DRUH shall transition between the states indicated in Table VI in accordance with the conditions listed in Table VII.

**NOTE:** Functional states are used to describe required DRUH functionality. In general, state transition conditions are described in terms of responses that can be observed on the host interfaces. These descriptions are not intended to specify how functions are internally implemented.

Table VI - DRUH functional state transition matrix.

New State → ↓ Current State ↓	FS1	FS2	FS3	FS4	FS5	FS6	FS7	FS8	FS9	FSa
FS1 - Initialization		T12	T13							T1a
FS2 - Accelerated Align	T21		T23		T25	T26			T29	T2a
FS3 - Static Align	T31	T32		T34	T35	T36			T39	T3a
FS4 - Interrupted Static Align	T41		T43						T49	T4a
FS5 - Dynamic Align	T51		T53			T56			T59	T5a
FS6 - Survey	T61						T67	T78	T89	T6a
FS7 - Air Transport	T71					T76			T79	T7a
FS8 - Marine Transport	T81					T86			T89	T8a
FS9 - Restart Required	T91									T9a
FSa - Shutdown Complete										

3.3.8.1 Initialization. Except where noted, within 20 seconds after application of power or after acceptance of a RESTART command the DRUH shall:

- a. Initialize STATUS DATA, ALERT DATA, and BIT DATA in accordance with Appendix B.
- b. Set ALERT DATA D5/3 (Configuration Data Not Present) if configuration data are not present. Set ALERT DATA D5/4 (Pointing Device Boresight Angles Not Present) if pointing device boresight angles are not present. Set ALERT DATA D2/7 (Vehicle Boresight Angles Not Present) if vehicle boresight angles are not present. While ALERT DATA D5/3, D5/4, or D2/7 is set, the STATUS DATA bits listed in Table VIII shall remain in the states indicated.
- c. Determine BIT status of itself, and if there is any DRUH failure, set BIT DATA D1/7 (DRUH Fail). BIT DATA D1/6 (DRUH Inertial Fail) shall be set to indicate that DRUH determined position, attitude and rate data may be invalid. BIT DATA D1/5 (DRUH Non-Inertial Fail) shall be set to indicate that all transmitted data may be invalid.
- d. Set ALERT DATA D1/0 (Previous Shutdown Abnormal) and STATUS DATA S1/1 (Position Update Request) if the last shutdown was abnormal.

Exception: These bits shall not be set again for RESTART if previously reset.

Table VII - DRUH state transition conditions.

Transition(s)	Functional State Transition Conditions
T12	S1/6 (DRUH Startup Complete) transitions to 1 AND DRUH was shutdown with STORED HEADING SHUTDOWN Cmd. AND ALERT D1/0 (Previous Shutdown Abnormal) = 0 AND no RESTART command has been accepted
T13	S1/6 (DRUH Startup Complete) transitions to 1 AND [DRUH was shutdown with a SHUTDOWN Cmd. OR ALERT D1/0 (Previous Shutdown Abnormal) = 1 OR a RESTART command was previously accepted]
T1a, T2a, T3a, T4a, T5a, T6a, T7a, T8a, T9a	S4/4 (DRUH Shutdown Complete) = 1
T21, T31, T41, T51, T61, T71, T81, T91	RESTART command accepted
T23	Unable to successfully complete Accelerated Align
T25, T35	S3/2 (DRUH in Motion) = 1 AND S5/6 (GPS Enabled) = 1
T26	Accelerated Align successfully completed
T29	[S3/2 (DRUH in Motion) = 1 AND S5/6 (GPS Enabled) = 0] OR ALERT D3/1 (Excessive Rates) = 1
T32	STORED HEADING ALIGN command accepted
T34	[S3/2 (DRUH in Motion) = 1 AND S5/6 (GPS Enabled) = 0] AND S1/4 (Ok to Move) = 1
T36	Static Align successfully completed
T39, T49	[ALERT D1/0 (Previous Shutdown Abnormal) = 1 AND 3.5 minutes of Static Align has been completed] OR ALERT D2/3 (Align Interrupt) = 1 OR ALERT D2/4 (Unable to Complete Align) = 1 OR ALERT D3/1 (Excessive Rates) = 1
T43	S3/2 (DRUH in Motion) = 0 AND a ZUPT has been completed
T53	[S3/2 (DRUH in Motion) = 0 AND a ZUPT has been completed] OR {[S1/4 (Ok to Move) = 1 OR S3/2 (DRUH in Motion) = 0] AND [an ENABLE INERTIAL MODE command is received OR a GPS failure is detected]}
T56	Dynamic Align successfully completed with estimated azimuth error $\leq 1.0$ mil PE
T59	ALERT D2/4 (Unable to Complete Align) = 1 OR ALERT D3/1 (Excessive Rates) = 1 OR estimated azimuth error $> 3.0$ mils PE at end of nominal Dynamic Align Interval OR estimated azimuth error $> 1.0$ mils PE at end of extended Dynamic Align Interval
T67	AIR TRANSPORT command accepted
T68	MARINE TRANSPORT command accepted
T69, T79, T89	ALERT D3/1 (Excessive Rates) = 1
T76, T86	TRANSPORT COMPLETE command accepted

Table VIII - Initial STATUS settings.

STATUS DATA bit	STATE
S1/7 (DRUH In Startup)	set
S1/5 (DRUH In Align)	reset
S1/4 (OK To Move)	reset
S5/4 (DRUH In Dynamic Align)	reset
S2/2 (DRUH In Stored Heading Align)	reset

- e. After configuration data are present, check the GPS Installed flag (CFIG D27/7). If the flag is reset, the DRUH shall not: enable GPS aiding; or report GPS receiver, GPS Communication or GPS Antenna failures.

If the flag is set, the DRUH shall determine BIT status of the GPS receiver, GPS Communications and GPS Antenna and set BIT DATA D2/2 (GPS Fail), D2/3 (GPS Communication Fail), or D2/4 (GPS Antenna Fault), as applicable. If BIT DATA D2/4 is reset, GPS aiding shall be enabled. If BIT DATA D2/4 is set, GPS aiding shall be inhibited.

- f. After configuration data are present, check the Odometer Installed flag (CFIG D29/0). If the flag is reset, the DRUH shall set STATUS DATA S1/3 (VMS Inhibited) and shall not report VMS and VMS Drive failures.

If the flag is set, the DRUH shall initiate VMS hardware BIT. VMS BIT shall not be initiated prior to 3 seconds after application of power. If there is a BIT failure, the DRUH shall set BIT DATA D2/1 (VMS Fail) and STATUS DATA S1/3 (VMS Inhibited).

Exception: VMS BIT is not required after acceptance of a RESTART command if VMS BIT already was passed.

- g. After configuration data are present, set STATUS DATA S2/4 (Pointing Device In Travel Lock) unless: the Travel Lock Discrete flag (CFIG D29/3) is set and the Travel Lock Discrete indicates that the pointing device is out of travel lock; or the Travel Lock Commands flag (CFIG D29/4) is set and an OUT OF TRAVEL LOCK command has been received. Determination of the Travel Lock Discrete state shall not be made prior to 3 seconds after application of power.
- h. Respond to commands, received on the Host RS-422 and 1553 data interfaces, within 10 seconds after power-on.
- i. If initial position parameters have not been received, set ALERT DATA D2/6 (Align Initial Position Parameters Not Received).

- j. After configuration data are present, if the previous shutdown was normal and the Reset Relative Offsets flag (CFIG D28/3) is reset, set the relative offsets to their stored values and STATUS DATA S2/0 (Relative Offsets Determined) to its stored state. Otherwise, set the relative offsets to zero and reset STATUS DATA S2/0.

Exception: Previously determined relative offsets and state of STATUS DATA S2/0 shall be retained following acceptance of a RESTART command.

- k. Reset STATUS DATA S1/7 (DRUH In Startup) and set STATUS DATA S1/6 (DRUH Startup Complete) when: steps a. through j., above, have been completed; ALERT DATA D5/3, D5/4, and D2/7 all are reset; and the DRUH is ready to align.

- l. Transition to Align.

3.3.8.2 Position initialization. Before completing Accelerated Align, Static Align, or Dynamic Align and proceeding to Survey, the DRUH shall initialize position. Sources of initial positions, in priority order, shall be:

- a. Position stored at shutdown, if in Accelerated Align.
- b. Host position update via ACCEPT POSITION or ACCEPT GEODETIC DATA commands.
- c. GPS data when STATUS DATA S6/1 (EPE  $\leq$  GPS Good Level) is set.
- d. GPS data when STATUS DATA S6/6 (Degraded GPS Enabled) and S6/0 (EPE  $\leq$  GPS Poor Level) are set.
- e. Position stored at shutdown, if ALERT DATA D1/0 (Previous Shutdown Abnormal) is reset.
- f. GPS data when ALERT DATA D1/0 (Previous Shutdown Abnormal) and STATUS DATA S6/0 (EPE  $\leq$  GPS Poor Level) are set.

3.3.8.2.1 Host update after normal shutdown. If ALERT DATA D1/0 (Previous Shutdown Abnormal) is reset, the DRUH shall accept initial parameters input, using the ACCEPT POSITION or ACCEPT GEODETIC DATA commands, at anytime during Static Align if acceptance criteria are met (3.3.7.5.7.1 and 3.3.7.5.7.2). If one of these commands is accepted, ALERT DATA D2/6 (Align Initial Position Parameters Not Received) shall be reset. Until one of these commands is accepted, the DRUH shall use the current stored or GPS position and the stored datum.

ALERT DATA D2/6 (Align Initial Position Parameters Not Received) shall be reset at successful completion of Static Align.

3.3.8.2.2 Host update after abnormal shutdown. If ALERT DATA D1/0 (Previous Shutdown Abnormal) is set, the DRUH shall accept initial parameters input, using the ACCEPT POSITION or ACCEPT GEODETIC DATA commands, during the first 3.5 minutes of Static Align, if acceptance criteria are met (3.3.7.5.7.1 and 3.3.7.5.7.2).

On acceptance of the initial parameters: align may automatically be restarted; and STATUS DATA S1/1 (Position Update Request), ALERT DATA D2/6 (Align Initial Position Parameters Not Received), and ALERT DATA D1/0 (Previous Shutdown Abnormal) shall be reset.

3.3.8.2.3 Host update during accelerated align. If the DRUH receives a valid ACCEPT POSITION or ACCEPT GEODETIC DATA command while in Accelerated Align, the DRUH shall accept the command but may delay parameter update until transition to Survey or Static Align while stationary. STATUS DATA S2/6 (Datum or Position Update In Progress) shall be set while the update is pending.

If STATUS DATA S3/2 (DRUH In Motion) becomes set, the DRUH shall: reject a pending position update; and set ALERT DATA D2/2 (Position Update Interrupt); and reset STATUS DATA S2/6 (Datum or Position Update In Progress).

3.3.8.2.4 Initialization with GPS data. During Static Align, if a position update has not been accepted via an ACCEPT POSITION or ACCEPT GEODETIC DATA command and if STATUS DATA S5/6 (GPS Enabled) is set and:

- a. If STATUS DATA S6/1 (EPE  $\leq$  GPS Good Level) is set or [S6/0 (EPE  $\leq$  GPS Poor Level) is set and S6/6 (Degraded GPS Enabled) is set], the DRUH shall: initialize position parameters using GPS data, reset ALERT DATA D2/6 (Align Initial Position Parameters Not Received), reset ALERT DATA D1/0 (Previous Shutdown Abnormal), and reset STATUS DATA S1/1 (Position Update Request).
- b. If ALERT DATA D1/0 (Previous Shutdown Abnormal) is set, and STATUS DATA S6/1 (EPE  $\leq$  GPS Good Level) is reset and S6/0 (EPE  $\leq$  GPS Poor Level) is set, the DRUH shall perform an initial position parameters update using GPS data, reset ALERT DATA D2/6 (Align Initial Position Parameters Not Received), and reset ALERT DATA D1/0 (Previous Shutdown Abnormal).

The DRUH shall initialize position, as specified above, at 120 seconds after entering Static Align or when GPS data meeting the acceptance criteria are available, whichever is later. If orientation parameters are not sufficiently determined to accurately offset the GPS antenna location to the DRUH, when initialization is performed, the DRUH position shall be reinitialized when adequate orientation data are available. The DRUH may restart Static Align when position is initialized using GPS data.

3.3.8.3 Accelerated align. Accelerated Align shall be completed within 60 seconds after entry. For successful Accelerated Align completion, the DRUH may require that: the last shutdown was normal; and the DRUH remained stationary since the last shutdown. Before indicating successful Accelerated Align completion, the DRUH shall automatically transition to another align sub-mode if there is a high probability the DRUH coordinate frame is not accurately aligned to the earth referenced coordinate frame.

3.3.8.3.1 VMS aiding after accelerated align. Upon successful completion of Accelerated Align, the DRUH may inhibit use of VMS aiding and set STATUS DATA S1/2 (ZUPT Stop Request), after each 3.75 minutes of travel since the last stop or GPS position update, until stopped time or valid GPS data with EPE  $\leq$  the configuration data GPS EPE Good Value have been accumulated for 5 minutes.

3.3.8.4 Static align. The DRUH shall complete Static Align, within the time specified in configuration data, without requiring stored or entered orientation data. The DRUH shall be capable of Static Align in any orientation and after being elevated/rotated from its normal travel position.

STATUS DATA S1/4 (OK To Move) shall be set when the Interrupted Static Align Performance Criteria (3.6.2) can be met after movement, no later than 3.5 minutes after Static Align entry.

A reasonableness test shall be performed prior to completing Static Align. If the initial position or instrument biases are unreasonable; or if STATUS DATA 3/1 (Orientation Attitude Data Valid) is reset when Align Time To Go reaches zero, the DRUH shall transition to the Restart Required state.

3.3.8.5 Interrupted static align. In Static Align, if GPS aiding is inhibited and STATUS DATA S3/2 (DRUH In Motion) and S1/4 (OK To Move) are set, the DRUH shall transition to Interrupted Static Align.

In interrupted Static Align, STATUS DATA S1/2 (ZUPT Stop Request) may be set after each period of 3.75 minutes (minimum) of travel. Align Time To Go is not required to decrement: while STATUS DATA S3/2 (DRUH In Motion) is set; or for 30 seconds after stopping; or while excessive motion disturbances are present.

3.3.8.6 Dynamic align. In Accelerated or Static Align, if GPS aiding is enabled and STATUS DATA S3/2 (DRUH In Motion) is set, the DRUH shall transition to Dynamic Align. The DRUH shall not require stops or host position updates during Dynamic Align.

3.3.8.7 Survey. The DRUH shall successfully complete Align prior to entering Survey. During survey, the DRUH shall provide position, orientation and angular rate parameters to the accuracy requirements specified in 3.6.2. The DRUH may use any available and enabled aiding source during Survey.

3.3.8.8 Air transport. Air Transport shall allow the DRUH to operate while being transported by aircraft, for periods up to 2 hours in duration, without requiring realignment to restore normal survey accuracy upon transport completion. In Air Transport: VMS aiding shall be inhibited; ZUPTs and ZUPT requests shall be enabled before takeoff and inhibited during flight; and altitude shall not be fixed prior to takeoff or if usable GPS data are available.

3.3.8.9 Marine transport. Marine Transport shall allow the DRUH to operate while being transported by watercraft, for periods up to 2 hours in duration, without requiring realignment to restore normal survey accuracy upon transport completion. In Marine Transport: VMS aiding, ZUPTs and ZUPT requests shall be inhibited; and altitude shall not be fixed if usable GPS data are available.

3.3.8.10 Restart required. The DRUH shall be in the Restart Required state when it was unsuccessful in completing align or a condition was encountered which could result in seriously degraded accuracy.

3.3.8.11 Shutdown complete. The DRUH shall be in the Shutdown Complete state when a SHUTDOWN or STORED HEADING SHUTDOWN command was accepted, data has been saved for shutdown, and power can be removed without causing an abnormal shutdown condition. The DRUH shall enter Shutdown Complete within 4.5 seconds after receipt of the first bit of the initiating command. When in Shutdown Complete, the DRUH shall respond to data request commands but is not required to change operating modes.

3.3.9 BIT. The DRUH shall detect and report at least ninety-five percent of all malfunctions occurring in the DRUH. A

BIT indication of a malfunction when there is no actual malfunction is considered a malfunction.

The DRUH shall: utilize VMS and GPS receiver BIT; monitor VMS and GPS performance; and report VMS, VMS Drive, GPS receiver, GPS Communications and GPS Antenna failures.

3.3.9.1 BIT indications. Two BIT indicators (DS) shall be provided as shown in Appendix F. DS-1 shall indicate by a green display that the DRUH is receiving proper primary power. DS-2 shall indicate by a green display that the DRUH is operating correctly. The BIT indicators shall indicate a failed condition by a black or non-illuminated display.

Failure of the DRUH, GPS receiver, GPS Communications, GPS Antenna, VMS, or VMS Drive shall be reported over the serial data buses in accordance with Appendices A, B and D.

3.3.9.2 Turn-on BIT. At turn-on, if primary power voltage is outside the specified limits: the DRUH shall remain off, and DS-1 shall indicate a failed condition. If power is acceptable, the DRUH shall energize.

3.3.9.3 Initialization BIT. After being energized at turn-on or when commanded to RESTART, the DRUH shall perform BIT of itself. If the Odometer Installed flag (CFIG D29/0) is set, the DRUH shall perform VMS BIT; if reset, the DRUH shall not report VMS failures. If the GPS Installed flag (CFIG D27/7) is set, the DRUH shall perform/monitor GPS related BIT; if reset, the DRUH shall not report GPS failures.

3.3.9.4 Operational BIT. In addition to 3.3.9, the DRUH shall perform BIT as specified in the following subparagraphs during operation.

3.3.9.4.1 DRUH BIT. If primary power is outside acceptable limits, the DRUH shall de-energize, and DS-1 shall indicate a failed condition.

ALERT DATA D1/2 (DRUH Over Temperature) shall be set if the DRUH temperature is high enough to cause degraded accuracy. The DRUH shall automatically de-energize if the temperature is high enough to cause damage.

ALERT DATA D3/1 (Excessive Rates) shall be set if dynamic conditions have exceeded the DRUH capability to maintain specified accuracy requirements.

3.3.9.4.2 VMS BIT. If a VMS is used, the DRUH shall continuously evaluate the validity of VMS data. Should VMS data

be persistently in error or if there is a significant loss of VMS data, the DRUH shall:

- a. Set BIT DATA D2/1 (VMS Fail) and D2/0 (VMS Drive Fail).
- b. Automatically perform VMS hardware BIT, which may be delayed until the host is stopped:
  - (1) If the VMS passes hardware BIT, BIT DATA D2/1 (VMS Fail) and D2/0 (VMS Drive Fail) shall remain set.
  - (2) If the VMS fails hardware BIT, BIT DATA D2/1 (VMS Fail) shall remain set and D2/0 (VMS Drive Fail) shall be reset.

3.3.9.4.3 GPS BIT. When a GPS receiver is configured, the DRUH shall report GPS Fail BIT, GPS Communication BIT, and GPS Antenna Fault. The DRUH shall command test of the GPS receiver after recovery from a GPS communication loss of more than 120 seconds.

3.3.9.4.3.1 GPS fail BIT. If a RPU failure is indicated in GPS message #3 (Time mark data), the DRUH shall inhibit GPS aiding, reset STATUS DATA S5/6 (GPS Enabled), and set BIT DATA D2/2 (GPS Fail). BIT DATA D2/2 shall not be reset until (a RESTART command has been accepted or an ENABLE INTEGRATED MODE command has been received) and GPS data indicates no RPU failure.

3.3.9.4.3.2 GPS communication BIT. The DRUH shall monitor the GPS RS-422 data bus and the GPS 1PPS Discrete for proper communications. BIT DATA D2/3 (GPS Communication Fail) shall be set if communications are improper. BIT DATA D2/3 shall be reset when proper communications with the GPS receiver are established.

3.3.9.4.3.3 GPS antenna fault. BIT DATA D2/4 (GPS Antenna Fault) shall be set if the GPS Antenna Source, in GPS Message #5040 (Current Status), differs from that specified by the Integral/External Antenna flag (CFIG D27/3). BIT DATA D2/4 shall be reset when matching antenna sources are indicated. GPS aiding shall be inhibited when BIT DATA D2/4 is set.

3.3.10 GPS receiver control. When the GPS Installed flag (CFIG D27/7) is set, the DRUH shall: attempt to exchange messages with and control the GPS receiver, and report GPS status and warnings. When the GPS Installed flag is reset, the DRUH shall not: exchange messages with or control the GPS receiver; and report GPS related BIT failures.

3.3.10.1 GPS receiver initialization. Unless modified by receipt of a command (3.3.10.2), the DRUH shall initialize the GPS receiver as specified in Table IX.

Table IX. GPS receiver initial settings.

PARAMETER	SETTING
Mode	Continuous mode
Keyboard/display	Disable keyboard/display
SV Type	SV type stored at previous shutdown; or P- or Y-code if ALERT DATA D1/0 (Previous Shutdown Abnormal) is set.
Coordinate Reference	Lat/Lon in deg/min if the Geodetic/Grid GPS Data flag (CFIG D27/2) is set; or UTM/UPS if CFIG D27/2 is reset and ALERT DATA D1/0 is reset and the Host Grid = UTM; or UTM/UPS if CFIG D27/2 is reset and ALERT DATA D1/0 is set; or BNG if CFIG D27/2 is reset and ALERT DATA D1/0 is reset and the Host Grid = BNG.
Distance Units	metric
Elevation Units	meters
Elevation Reference	MSL
Angular Units	mils
North Reference	True North if CFIG D28/0 (Geodetic/Grid Azimuth) is set, or Grid North if D28/0 is reset.
MVAR Type	calculated by system
Navigation Type	2D Fast
Elevation Hold Type	manual
Time Reference	UTC time (ZULU)
Error Units	distance
Selected Datum	0
Auto Timer Off	5 minutes
HaveQuick	ON
1PPS	time mark
Datum Identifier	Datum identifier stored at previous shutdown; or WGD (WGS 84) if ALERT DATA D1/0 (Previous Shutdown Abnormal) is set.

3.3.10.2 Updating GPS receiver settings. The DRUH shall update GPS receiver settings of the parameters listed in Table X upon acceptance of any of the listed commands. If the DRUH and GPS receiver are not communicating when a command listed in Table X is received, the DRUH shall initialize or update the GPS

receiver, using the new settings, when communications are (re)established.

Table X. GPS receiver settings update.

PARAMETER	COMMAND(S)
SV Type	SELECT Y-CODE ONLY SATELLITES, SELECT P OR Y-CODE SATELLITES, or PASS GPS SETUP DATA
Coordinate Reference	For ACCEPT CONFIGURATION DATA, ACCEPT POSITION or ACCEPT GEODETIC DATA set to: Lat/Lon in deg/min if the Geodetic/Grid GPS Data flag (CFIG D27/2) is set; or UTM/UPS if CFIG D27/2 is reset and ALERT DATA D1/0 is reset and the Host Grid = UTM; or UTM/UPS if CFIG D27/2 is reset and ALERT DATA D1/0 is set; or BNG if CFIG D27/2 is reset and ALERT DATA D1/0 is reset and the Host Grid = BNG. or PASS GPS SETUP DATA
Distance Units	PASS GPS SETUP DATA
Elevation Units	PASS GPS SETUP DATA
Elevation Reference	PASS GPS SETUP DATA
Angular Units	PASS GPS SETUP DATA
North Reference	ACCEPT CONFIGURATION DATA set to: True North if CFIG D28/0 (Geodetic/Grid Azimuth) is set, or Grid North if D28/0 is reset. or PASS GPS SETUP DATA
MVAR Type	PASS GPS SETUP DATA
Entered MVAR	PASS GPS SETUP DATA
Navigation Type	PASS GPS SETUP DATA
Elevation Hold Type	PASS GPS SETUP DATA
Time Reference	PASS GPS SETUP DATA
Error Units	PASS GPS SETUP DATA
Datum Identifier	ACCEPT POSITION, or ACCEPT GEODETIC DATA

3.3.10.3 GPS at shutdown. The DRUH shall command the GPS receiver at shutdown as specified in Appendix C.

3.3.10.4 GPS status reporting. The DRUH shall report the operational status of the GPS receiver as specified in Appendix B.

3.3.10.5 GPS warning messages. The DRUH shall receive and queue, for later transmission, a minimum of eight GPS Warning Messages from the GPS receiver. STATUS DATA S6/5 (GPS Warning Present) shall be set when a GPS Warning Message is received.

STATUS DATA S6/5 shall be reset when the last stored message has been deleted from the queue by the RETURN NEXT GPS WARNING or CUE NEXT GPS WARNING command. In the case of queue overflow, the oldest warning in the queue shall be replaced with the most recent.

3.3.11 Determination of travel lock. The DRUH shall select the method used to determine the travel lock state in accordance with the Travel Lock Discrete (CFIG D29/3) and Travel Lock Commands (CFIG D29/4) flags (see Appendix C.)

If the DRUH is "out of travel lock" at turn-on, vehicle attitudes and travel lock pointing device azimuth and pitch references shall be set to any allowable value if the orientation of the pointing device to the host is unknown.

3.3.11.1 Out of travel lock transition. When the travel lock state transitions to "out of travel lock", the DRUH shall: freeze vehicle attitudes; freeze and store travel lock pointing device references (azimuth and pitch) in terms of the appropriate Orientation (1 or 2); reset STATUS DATA S2/4 (Pointing Device in Travel Lock); inhibit VMS aiding; and if motion is detected, set ALERT DATA D3/0 (Motion with Pointing Device out of Travel Lock).

3.3.11.2 In travel lock transition. When the travel lock state transitions to "in travel lock", the DRUH shall: provide present vehicle attitudes; provide present pointing device azimuth and pitch for travel lock reference; set STATUS DATA S2/4 (Pointing Device in Travel Lock); enable VMS aiding and reset STATUS DATA S1/3 (VMS Inhibited), if the Odometer Installed flag (CFIG D29/0) is set; and reset ALERT DATA D3/0 (Motion With Pointing Device Out of Travel Lock).

3.3.12 Shot detect. When STATUS DATA S1/4 (OK to Move) is set and S2/4 (Pointing Device In Travel Lock) is reset, the DRUH shall report gunfire shocks 0.25 g or greater, at the sensor assembly, if the Shot Detect flag (CFIG D29/5) is set. Upon detection of gunfire, STATUS DATA S2/3 (Shot Detect) shall be set. At the completion of the Shot Detect Interval specified in configuration data, STATUS DATA S2/3 shall be reset.

3.3.13 Electrical interface. The electrical interface of the DRUH shall be as defined in the following subparagraphs. The electrical signals at the DRUH connectors consist of power, host RS-422 serial data signals, GPS serial data signals, VMS signals, travel lock discrete, GPS 1PPS signal, configuration selection discretetes, software download selection discretetes, MIL-STD-1553 data bus signals, MIL-STD-1553 Remote Terminal (R/T) address discretetes, and test signals.

3.3.13.1 Connectors. The DRUH shall have three external electrical connectors for interface with the host. The main signal connector (J1) shall conform to MS27468T19F35S. The power connector (J2) shall conform to MS27468T15F15P. The secondary signal connector (J3) shall conform to MS27468T19F35SB. J1, J2 and J3 shall be located, oriented and identified in accordance with Appendix F.

3.3.13.1.1 Connector pin functions. J1 pin functions shall be as specified in Table XI. Signal circuits shall be terminated in accordance with Figure 1. J2 pin functions shall be as specified in Table XII. J3 pin functions shall be as specified in Table XIII.

Table XI. J1 pin functions

J1 PIN	PIN FUNCTION	TERMINATION
1	Auxiliary Clock (RS-422) - Hi	A
2	Spare	
3	Software Load Discrete	
4	Auxiliary Data Bus (RS-422) - Hi	B
5	Auxiliary Clock (RS-422) - Lo	A
6	Spare	
7	Spare	
8	Main Clock (RS-422) - Hi	A
9	Main Clock (RS-422) - Lo	A
10	Auxiliary Data Bus (RS-422) - Lo	B
11	Signal Ground (for Configuration Discrete)	
12	On Power Control	
13	On Power Control	
14	Signal Ground (for Configuration Discrete)	
15	Spare	
16	Main Data Bus (RS-422) - Hi	B
17	Travel Lock Discrete (RS-422) - Hi	C
18	Travel Lock Discrete (RS-422) - Lo	C
19	Vehicle Configuration Discrete 3	
20	Chassis Ground	
21	24 VDC Return	
22	24 VDC Return	
23	24 VDC Return	
24	Main Data Bus (RS-422) - Lo	B
25	GPS Data Bus, Transmit (RS-422) - Hi	
26	Signal Ground (for Configuration Discrete)	
27	+15 VDC	
28	Vehicle Configuration Discrete 4	
29	+15 VDC	
30	+5 VDC	
31	+5 VDC	
32	Signal Ground (for Configuration Discrete)	

Table XI. J1 pin functions

J1 PIN	PIN FUNCTION	TERMINATION
33	Vehicle Configuration Discrete 1	
34	GPS Data Bus, Transmit (RS-422) - Lo	
35	Spare	
36	+5 VDC	
37	-15 VDC	
38	-15 VDC	
39	DC Return	
40	DC Return	
41	Signal Ground (for Configuration Discrete)	
42	Vehicle Configuration Discrete 2	
43	GPS Data Bus, Receive (RS-422) - Hi	
44	Signal Ground (for Configuration Discrete)	
45	DC Return	
46	Spare	
47	GPS 1PPS Discrete	
48	No connection (Reserved for host use)	
49	VMS BIT Command 2 (RS-422) - Hi	
50	VMS BIT Command 2 (RS-422) - Lo	
51	GPS Data Bus, Receive (RS-422) - Lo	
52	+24 VDC	
53	VMS Reverse Data (RS-422) - Hi	C
54	VMS Reverse Data (RS-422) - Lo	C
55	No Connection (Reserved for host use)	
56	Hybrid Configuration Discrete	
57	VMS BIT Command 1 (RS-422) - Hi	
58	+24 VDC	
59	+24 VDC	
60	Spare	
61	No Connection (Reserved for host use)	
62	Wired Spare 2 (Supplier Reserved)	
63	VMS BIT Command 1 (RS-422) - Lo	
64	VMS Forward Data (RS-422) - Hi	C
65	VMS Forward Data (RS-422) - Lo	C
66	Wired Spare 1 (Supplier Reserved)	

3.3.13.2 Bonding and shield grounding. When secured to a conductive metal mount, the resistance between the DRUH chassis and mount, through the electrical bonding surfaces identified in Appendix F, shall be less than 0.1 Ohm. Shields of external cables mating with J1, J2 and J3 will be terminated to the connector backshells. The impedance between J1, J2 and J3 connector shells and the DRUH chassis shall be less than 2.5 milliohms from DC to 10 MHz.

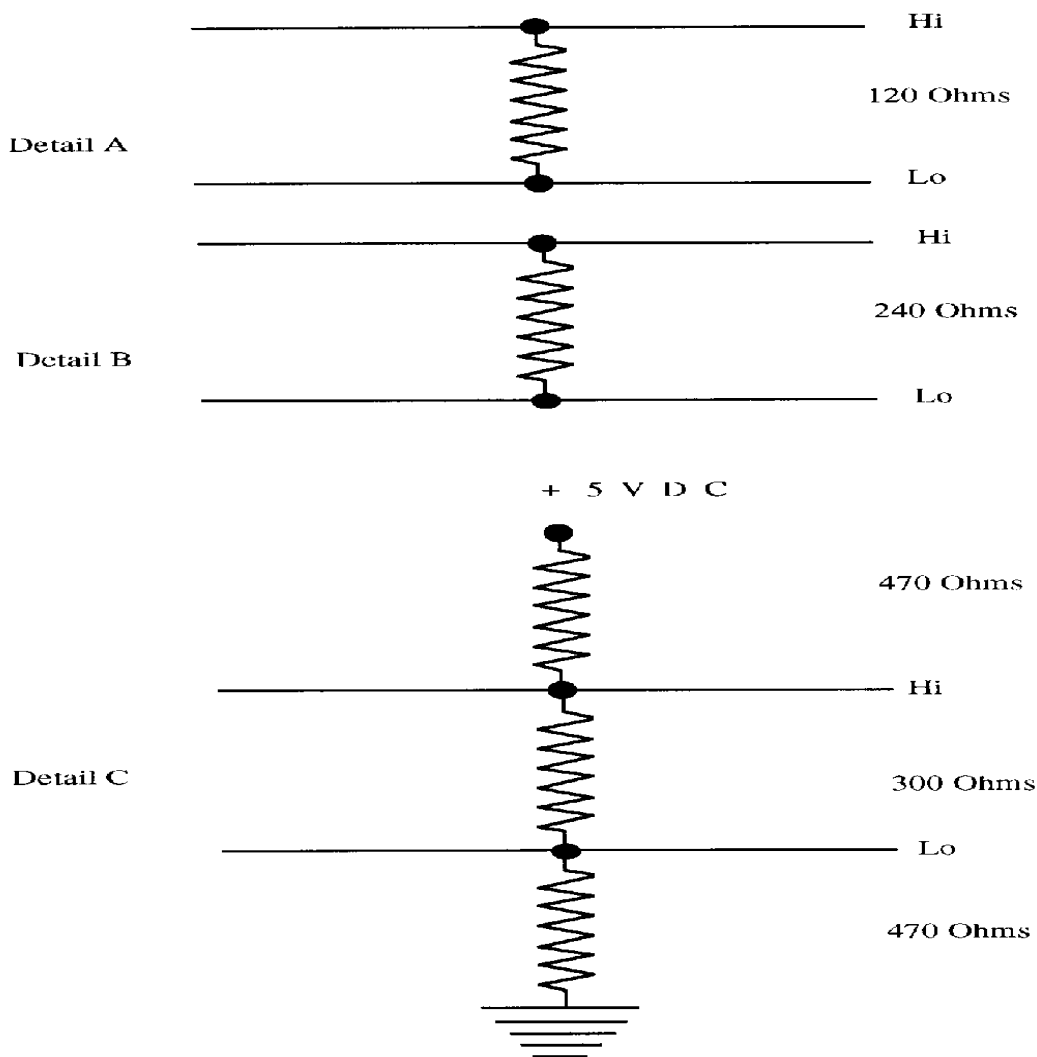

Figure 1. Termination details.

Table XII. J2 pin functions.

J2 PIN(S)	PIN FUNCTION
A	+24 VDC Power In
B	+24 VDC Power In
C	Power Control Designation
D	Power Control Designation
E - H, J - L, R	No Connection
M	DC Power Return
N	DC Power Return
P	Chassis Ground

Table XIII. J3 pin functions.

J3 PIN(S)	PIN FUNCTION
1	Contractor Identification Resistor (see note below)
2 - 4	Supplier Reserved
5	Contractor Identification Resistor (see note below)
6 - 33	Supplier Reserved
34	1553 Bus Address Bit 4
35	1553 Bus Address Common
36	1553 Bus Address Bit 3
37	1553 Bus Address Common
38	1553 Bus Address Bit 2
39	1153 Bus Address Common
40	1553 Bus Shield
41	1553 A Bus Transformer Hi
42	1553 A Bus Transformer Lo
43	1553 B Bus Transformer Hi
44	1553 B Bus Transformer Lo
45 - 53	Supplier Reserved
54	Signal Ground (for discretes)
55	1553 Bus Address Bit 1
56	1553 Bus Address Common
57	1553 Bus Address Bit 0
58	1553 Bus Address Common
59	1553 Bus Address Parity
60	1553 Bus Address Common
61	RS-422/1553 Load Discrete
62	Software Load Discrete
63 - 66	Spare

**NOTE:** Contractor ID Resistor ( $\pm 5$  percent); Honeywell = 10K, Other = Not Assigned

3.3.13.3 Power. The DRUH shall operate from power provided from a nominal 24 VDC vehicle power source. Input power for the DRUH and external devices drawing regulated power from the DRUH shall not exceed 150 watts. The DRUH shall:

- a. Activate and operate when the steady state primary power voltage is within the range 18.5 to 36.0 VDC and the host has requested turn-on (3.3.13.3.1).
- b. Remain activated and operational when the steady state primary power voltage is within the range 16.3 to 36.0 VDC.
- c. Be off when the steady state primary power voltage is 15.0 VDC or less.

- d. Operate with primary power ripple in the range of  $\pm 2$  Volts, from the steady state voltage, within the range of 50 Hz to 200 kHz.
- e. Operate with primary power surges and spikes in accordance with MIL-STD-1275. Power spikes may be limited to a range of  $\pm 100$  Volts.
- f. Not be damaged by primary power voltage polarity reversal.
- g. Not be damaged by surges, spikes, ripple, starting disturbances or steady state voltages within the range  $\pm 100$  Volts, peak, for normal operation, single fault conditions and multiple fault conditions of the primary power source, in accordance with MIL-STD-1275.
- h. Not be damaged by loss of power. Loss of power shall not affect DRUH computer program(s) or calibration data.
- i. Not require special alignment procedures after an unexpected power loss.

3.3.13.3.1 Power control. If an open circuit is present between pins C and D of J2, the DRUH shall:

- a. Automatically activate when the primary power is within the acceptable range (3.3.13.3).
- b. Deactivate when the primary power is outside the acceptable range (3.3.13.3). Acceptance of a SHUTDOWN or STORED HEADING SHUTDOWN command shall only initiate storage of data.
- c. After deactivation has started, reset to the beginning of initialization when acceptable primary power is next applied.

If a short circuit is present between pins C and D of J2, the DRUH shall:

- a. Activate when primary power is within the acceptable range and a momentary contact closure between pins 12 and 13 of J1 has occurred.
- b. Deactivate after completion of data storage following acceptance of a SHUTDOWN or STORED HEADING SHUTDOWN command or when the primary power is outside the acceptable range.

The voltage on J1 pins 12 and 13 shall not exceed the primary power voltage. The current flowing through J1 pins 12 and 13 shall not exceed 5.0 milliamperes.

The DRUH shall be able to reactivate within 5 seconds after power has been removed.

3.3.13.3.2 Overload protection. Current overload protection shall be provided. Current-interruption devices shall be used to open a circuit whenever a fault occurs. No over-current protective device shall be connected in series with any conductor that is grounded at the power source unless the device simultaneously opens all load conductors in the circuit and no pole operates independently.

Current overload protection devices shall not require manual reset. However, the host may be required to turn off primary power to reset overload protection.

The use of overload or other protective devices shall not alter the normal performance characteristics of the source or load.

3.3.13.3.3 Regulated power output. When activated, the DRUH shall supply the DC voltage and current requirements listed in Table XIV for external use.

Table XIV - External regulated power.

VOLTAGE	CURRENT	MAXIMUM RIPPLE
+15 VDC	350 ma	150 mv pk-pk
-15 VDC	350 ma	150 mv pk-pk
+5 VDC	700 ma	100 mv pk-pk

Output voltages shall be within  $\pm 5$  percent of the specified values including the effects of source and load regulation and ripple. Power supply outputs shall be protected from overloads and over voltages. The DRUH shall not deactivate or indicate a failure when momentary current surges are required to charge capacitors, up to 5 microfarads in value, in external devices powered by the DRUH.

3.3.13.3.4 Unregulated power output. The DRUH shall supply unregulated, 24 VDC, primary power for external use. This power output shall be active only when the DRUH has been activated. The load power will not exceed 32 watts and the surge current will not exceed 2.0 amperes. The DC returns, J1 pins 21 through 23, shall not connect to the DRUH chassis at any point.

3.3.13.4 RS-422 interfaces. The DRUH shall interface with the signals listed in Table XV, which shall be balanced

differential voltage circuits in accordance with EIA Standard RS-422:

3.3.13.4.1 RS-422 drivers and receivers. RS-422 line drivers shall comply with the generator electrical characteristics specified in RS-422. All RS-422 receivers shall comply with the requirements of RS-422 with the following changes:

- a. The common mode voltage range shall be  $\pm 15$  volts.
- b. Over the entire common mode voltage range, the receiver shall not require a differential input voltage of more than 500 millivolts to correctly assume the intended binary state.

The DRUH shall not be damaged or malfunction when RS-422 signal circuits are connected or disconnected with power on or off.

Table XV. RS-422 Signals.

RS-422 INTERFACE	SIGNAL(S)	DRUH INPUT/OUTPUT
Host Data (Appendix A)	Host Auxiliary Clock	Input
	Host Auxiliary Data Bus	Input/Output
	Host Main Clock	Input
	Host Main Data Bus	Input/Output
GPS Data (3.3.13.4.4) & Reprogramming	GPS Transmit Bus	Output
	GPS Receive Bus	Input
Travel Lock (3.3.13.4.5)	Travel Lock Discrete	Discrete Input
VMS (3.3.13.4.6)	VMS Bit Command 1	Discrete Output
	VMS Bit Command 2	Discrete Output
	VMS Forward Data	Pulse Input
	VMS Reverse Data	Pulse Input

3.3.13.4.2 RS-422 logic levels. A binary logic "1" or "set" condition shall be represented by a positive voltage on the "Hi" line with respect to the "Lo" line. A logic "0" or "reset" condition shall be represented by a positive voltage on the "Lo" line with respect to the "Hi" line.

3.3.13.4.3 Host RS-422 data interface. The DRUH shall have a host RS-422 data interface in accordance with Appendix A.

3.3.13.4.4 GPS RS-422 data interface. The DRUH shall have an asynchronous, bi-directional, full-duplex, serial RS-422 data bus for exchange of data messages between the DRUH and GPS receiver. The DRUH shall allow loading of new software,

configuration data and datum data via this interface. The input impedance of the GPS Receive bus shall be  $\geq 200$  Ohms.

3.3.13.4.4.1 GPS message characteristics. Protocols, formats, data elements, baud rates, and timing of messages exchanged by the DRUH and GPS receiver shall be as specified in ICD-GPS-153. The DRUH shall observe the ACK/NAK and handshaking requirements of ICD-GPS-153.

3.3.13.4.5 Travel lock discrete. If the Travel Lock Discrete flag (CONFIG D29/3) is set, the DRUH shall use the RS-422 travel lock discrete to determine whether the pointing device is in or out of travel lock. When the travel lock discrete signal is logic "0", the pointing device shall be considered in travel lock. When the travel lock discrete signal is logic "1", the pointing device shall be considered to be out of travel lock.

3.3.13.4.6 VMS interface. The DRUH shall accept forward and reverse odometer pulse signals,  $800 \pm 80$  micro-seconds in width at rates in the range of 0 to 711 pulses/second, from a VMS. The nominal scaling is 0.165 feet per pulse. The DRUH shall provide control signals (BIT Commands) to a VMS as specified in Table XVI.

Table XVI. VMS control and response signals.

BIT COMMAND		VMS RESPONSE (pulses/second)	
#1	#2	FORWARD PULSES	REVERSE PULSES
1	0	355 $\pm$ 53	0
0	1	0	355 $\pm$ 53
1	1	0	0
0	0	Normal Operating Condition	

3.3.13.5 GPS 1PPS interface. The DRUH shall accept GPS 1PPS time mark output pulses conforming to ICD-GPS-153.

3.3.13.6 Discrete interface. The DRUH shall provide four Vehicle Configuration Discretes, a Hybrid Configuration Discrete, and a Software Load Discrete on connector J1. An RS-422/1553 Load Discrete and Software Load Discrete shall be provided on connector J3. (The Software Load Discrete appears on both J1 and J3 to minimize cabling requirements for an external software load device.)

An open circuit shall indicate logic "0". A connection to signal ground shall indicate logic "1". The discrete input circuits shall require external drivers to source or sink no more than 2.0 milliamperes.

3.3.13.6.1 Vehicle configuration discrettes. Host Configuration Discrettes 1 through 4 shall be used to identify the configuration definition data to be used by the DRUH. Configuration codes and data are tabulated in Appendix C for specific hosts.

3.3.13.6.2 Hybrid configuration discrete. The DRUH shall use the Hybrid Configuration Discrete to determine which survey software functionality shall be used. If the discrete is a logic "1", the DRUH shall function as a DRU Hybrid, as specified herein. If a logic "0", the DRUH shall function in accordance with the requirements for the alternate software package.

3.3.13.6.3 Reprogramming discrettes. At power-on, the DRUH shall determine the state of the Software Load Discrete. If the Software Load Discrete is logic "0", the DRUH shall operate using the currently stored software. If logic "1", the DRUH shall accept and store new software from an external reprogramming device. If the RS-422/1553 Load Discrete is logic "0", the DRUH shall accept reprogramming data over the GPS RS-422 interface. If logic "1", over the MIL-STD-1553 interface.

3.3.13.7 1553 data interface. The DRUH shall have a MIL-STD-1553 interface in accordance with Appendix D. The DRUH shall allow loading of new software, configuration data and datum data via this interface.

3.3.14 Mechanical interface. Mechanical characteristics, mounting provisions, mechanical reference datums, and weight shall be in accordance with Appendix F.

3.3.15 Year 2000 (Y2K) compliance. The DRUH shall be Year 2000 compliant. The DRUH shall pass through two-digit years obtained from the GPS receiver in the messages specified in Appendices A and D without century processing.

3.4 Environmental requirements. Except as otherwise noted, the DRUH shall not be damaged while powered or non-powered, meet the interface requirements of 3.3 - 3.3.14 and meet the performance requirements of 3.6 - 3.6.6.2 operate under any combination of the environmental conditions specified below.

#### 3.4.1 Temperature.

3.4.1.1 Operational. The DRUH shall operate in ambient air and on a mount with temperatures within the range of +140°F (+60°C) to -50°F (-46°C).

3.4.1.2 Storage and transportation. The DRUH shall withstand storage and transportation temperatures from +160°F (+71°C) to -60°F (-51°C) without any deterioration or adverse effects that may cause failure when the DRUH is placed in operation.

3.4.2 Temperature shock. The DRUH shall not be damaged nor rendered inoperable when subjected to abrupt temperature changes from -60°F (-51°C) to +160°F (+71°C).

3.4.3 Altitude. The DRUH shall operate at altitudes from -1000 meters to +10,000 meters. The DRUH shall not be damaged by exposure to altitudes from -1000 to +21,336 meters.

3.4.4 Humidity. The DRUH shall not be damaged by operation, transportation, or storage with ambient relative humidity within the range of 1 to 100 percent.

3.4.5 Snow. The DRUH shall not be damaged and shall operate during and after exposure to:

- a. Falling snow with a rate of 3 inches per hour (76 mm/hr) and crystal size of  $2.0 \times 10^{-3}$  inch (0.05 mm) to 0.8 inch (20 mm) in diameter.
- b. Blowing snow with crystal size  $8.0 \times 10^{-3}$  inch (0.2 mm) to  $1.6 \times 10^{-2}$  inch (0.4 mm) diameter and winds of at least 16 ft/sec (5 m/sec).
- c. Snowload of 20 lbs/ft<sup>2</sup> (97.7 Kg/m<sup>2</sup>).

3.4.6 Ice. The DRUH shall not be damaged and shall operate during and after exposure to:

- a. Frost 3 inches (76 mm) thick with specific gravity of 0.2.
- b. Rime ice 6 inches (152 mm) thick with specific gravity of 0.2.
- c. Clear glaze ice 3 inches (76 mm) thick with specific gravity of 0.9.

3.4.7 Solar radiation. The DRUH shall operate during and after exposure to solar radiation of 360 BTU/ft<sup>2</sup>/hr (1135 watts/m<sup>2</sup>) for 4 hours at an ambient temperature of +125°F (+51.6°C) at winds of 8.5 ft/sec (2.6 m/sec) or less. Maximum solar radiation will be higher by 4 BTU/ft<sup>2</sup>/hr per 1,000 feet (43 w/m<sup>2</sup> per 1,000 m) and ambient air temperatures will be lower by

5°F per 1,000 feet for ground elevations above 3,000 feet, up to 15,000 feet.

3.4.8 Washdown. The DRUH shall suffer no damage or leakage when exposed to high pressure water washdown.

3.4.9 Salt fog. The DRUH shall not be damaged and shall operate without degradation to specified performance levels while being subjected to salt fallout of  $5.7 \times 10^{-4}$  lbs/ft<sup>2</sup>/year ( $2.8 \times 10^{-3}$  Kg/meter<sup>2</sup>/year).

3.4.10 Fungus. The DRUH shall not be damaged and shall operate after exposure for 90 days to a viable spore suspension containing at least the following fungi: Aspergillus Niger, Aspergillus Flavus, Aspergillus Versicolor, Penicillium Funiculosum, and Chaetomium Globosum.

3.4.11 Shock.

3.4.11.1 Operational (gunfire). When mounted in an M109A6 Self-Propelled Howitzer, the DRUH shall not be damaged and shall operate during and after repeated firing of all allowable combinations of rounds and charges. A non-operating DRUH shall not be damaged by gun firing shock.

3.4.11.2 Transportation. The DRUH shall not be damaged and shall operate during and after exposure to multiple sawtooth shock pulses with 40g peak amplitude and 6-9 milliseconds duration, in any direction.

3.4.11.3 Bench handling. With covers removed as for maintenance, the DRUH shall not be damaged and shall operate after a face has been dropped onto a horizontal wooden bench top after one edge has been raised 4 inches above the bench top with the opposite edge resting on the bench top. The DRUH shall withstand multiple drops onto all practical faces about all practical edges.

3.4.12 Vibration. The DRUH shall operate and not be damaged while being subjected to the vibration environment of the M109A6 Howitzer, M113 Armored Personnel Carrier, High Mobility Multi-purpose Wheeled Vehicle (HMMWV) and Commercial Utility Cargo Vehicle (CUCV) traveling over all types of roads and cross-country terrain at speeds ranging from zero to the maximum attainable. A non-operating DRUH shall not be damaged by the vibration environment.

3.4.13 Electromagnetic compatibility/interference (EMI/EMC). The DRUH shall meet the following MIL-STD-461 emission and susceptibility requirements: CE101 (Army aircraft, curve 2),

CE102, CS101 (curve 2), CS114 (curve 5), CS115, RE102 (Army aircraft), RSO1 (Army only), and RS103. Field strengths for RS103 shall be:

Frequency Range	Average Field Strength
10 kHz to 2 MHz	25 V/m
2 MHz to 1 GHz	50 V/m
1 GHz to 18 GHz	200 V/m

3.4.14 Electrostatic discharge. The DRUH shall not be damaged and shall operate as specified in 3.4 after being charged to potential differences of up to 300,000 volts with respect to ground potential, across a capacitance of 1,000 picofarads, and subsequently being discharged to ground potential through a series resistance of 500 ohms. Circuit modules and repair parts shall not be damaged by electrostatic discharge generated by normal handling during maintenance.

3.4.15 Lightning. The DRUH shall not be damaged and shall operate as specified in 3.4 after being subjected to close lightning strikes at distances of 10 meters or greater. The idealized current waveform generated by severe lightning strike is shown in Figure 2. Field strengths at 10 meters are:

Peak Magnetic Field            3,200 A/m  
Peak Electric Field            3        MV/m

Electric Field Spectral Density:

Frequency	Field Density (V/m/Hz)
10 Hz	160
100 Hz	3
1 kHz	0.5
10 kHz	500
40 kHz	5,000

The DRUH is permitted to turn off, without damage or loss of data needed to reinitialize, when exposed to close lightning strikes.

3.4.16 Explosive atmosphere. The DRUH shall preclude ignition or explosion when operated in hazardous atmospheres.

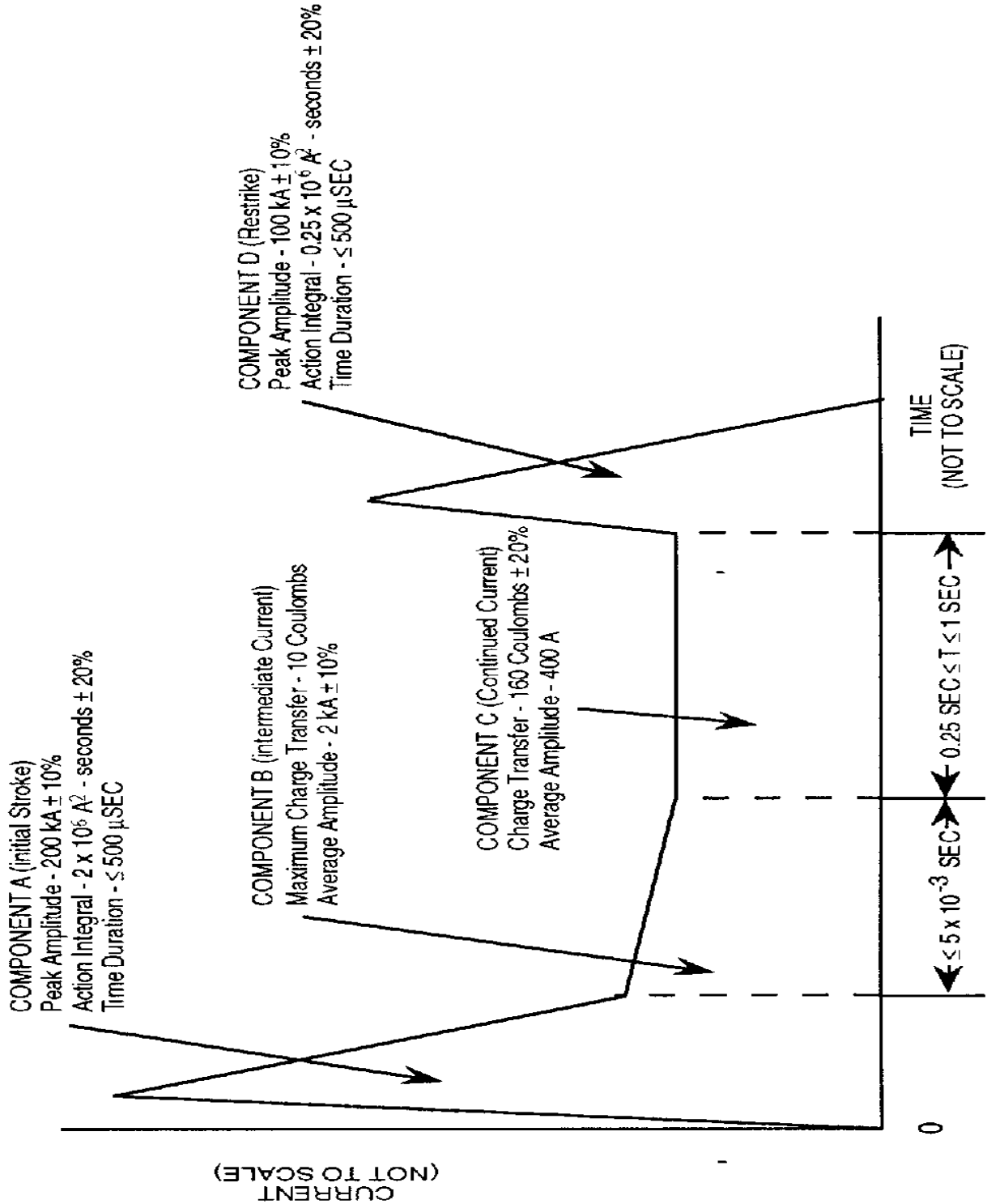

Figure 2. Lightning current pulse.

3.4.17 NBC survivability. The DRUH shall operate in and withstand an NBC contaminated environment as stated below.

3.4.17.1 Contamination/decontamination. NBC contamination and decontamination shall not damage the DRUH. After contamination and decontamination, the NBC contamination remaining on, or desorbed or reaerolized from, the DRUH shall result in no more than a negligible risk (see Table XVII) to unprotected personnel working on or around the DRUH. Information on decontamination agents and procedures may be found in FM 3-5.

No NBC contaminants or decontaminants shall be entrapped by the DRUH. Disassembly shall not be required to remove NBC contaminants or decontaminants.

Table XVII. Negligible risk values for NBC Contaminants.

CONTAMINANT	AMOUNT	
<b>CHEMICAL</b>	<b>VAPOR/AEROSOL</b>	<b>LIQUID (skin dose)</b>
VX	0.25 mg min/m <sup>3</sup>	1.4 mg/70-kg man
GD	2.5 mg min/m <sup>3</sup>	30 mg/70-kg man
HD	50 mg min/m <sup>3</sup>	0.01 mg/cm <sup>2</sup>
<b>BIOLOGICAL</b>	500 spores/m <sup>2</sup>	
<b>RADIOLOGICAL</b>	<b>maximum 12 hour exposure</b>	
Contaminants	25 cGy (rad)	
Induced Activity	25 cGy (rad)	

3.4.17.2 Hardness. The DRUH shall be hardened to ensure that degradation over a 30-day period of no more than 20 percent in reliability, availability, and maintainability caused by 5 exposures to NBC contaminants, decontaminants, and decontaminating procedures.

3.4.17.3 Induced activity. When exposed to neutron fluence from a nuclear detonation that results in a total dose of 3,000 cGy (rad), the neutron induced activity in the DRUH shall result in no more than a negligible risk (as defined in Table XVII) to unprotected personnel arriving 2 hours after detonation and remaining at a distance of 1 meter for 12 hours.

3.4.17.4 Compatibility. Personnel wearing the full NBC protective ensemble must be able to maintain the DRUH.

3.4.18 Nuclear survivability. The DRUH shall not be damaged after exposure to the nuclear environment as specified in "Nuclear Survivability Criteria for the Modular Azimuth Position System (MAPS) equipment survivability category: man in truck or signal shelter, equipment exposed". The DRUH is permitted to turn off, without damage, when exposed to nuclear events. After such a shutdown, the DRUH shall not turn on until power has been disconnected and reapplied and when reinitialized shall perform

as specified. Design margins shall be as specified in Table XVIII.

Table XVIII. Nuclear design margins.

ENVIRONMENT	Design Margin Category	
	I	II
Initial Radiation		
Neutron Fluence	2 to 10	> 10
Total Dose	2 to 10	> 10
Gamma Dose Rate		
Upset	2 to 10	> 10
Burnout	2 to 10	> 10
Latchup	2 to 5	> 5
EMP		
Voltage and Current ratios (Corresponding Design Margin for Power Dissipation)	2 to 10 6 to 20 dB	> 10 > 20 dB
Thermal Fluence	1.3 to 1.5	> 1.5
Air-Blast Peak Overpressure	1.3 to 1.5	> 1.5

Items are unacceptable when the design margin falls below the lower bound of Category I. If possible, the contractor shall avoid using items having design margins in the Category I range because there could possibly be significant hardness assurance/hardness maintenance impacts later in the life cycle. The contractor shall strive to incorporate Category II parts. Category II items shall be identified as Category IIA or IIB. The former refers to items that are special design/fabrications to achieve the nuclear hardness levels; the latter refers to items for which no special processes were incorporated to achieve the items' nuclear hardness.

### 3.5 Support or ownership requirements.

3.5.1 Reliability. The DRUH shall have a Mean-Time-Between-Failure (MTBF) of 4000 hours or greater.

Failure of the GPS receiver or VMS shall not inhibit the ability of the DRUH to operate.

3.5.2 Maintainability. The DRUH shall be designed for ease and economy of maintenance, as defined in the subparagraphs below.

3.5.2.1 Corrective maintenance. The DRUH shall, upon occurrence of a single malfunction, be restored to operation, by replacement, within a meantime-to-repair (MTTR) of 30 minutes at the organizational level. Times include fault isolation,

removal, and replacement, but do not include supply and administration time.

3.5.2.2 Preventive maintenance. The DRUH shall not require any preventative maintenance other than cleaning of exterior surfaces to remove dust, dirt, and other foreign material.

3.5.2.3 Adjustments/calibration. The DRUH shall not require any adjustments or calibrations in the field that require operator interaction, nor shall the DRUH require stops more frequently than stated herein.

3.5.3 Materials, processes, and parts. Materials, processes and parts shall be selected to meet all operational, environmental, and useful life requirements specified herein.

3.5.4 Elapsed time indicator. The DRUH shall display its cumulative operating time. The elapsed time indicator shall: be located and identified in accordance with Appendix F; be visible from outside the DRUH case without degrading case environmental sealing; be readable whether the DRUH is powered or not; have a minimum range of 0 - 9,999 hours; and have a resolution no coarser than 1 hour.

3.5.5 Illumination. No light shall be visible from the DRUH in normal operation. The elapsed time and BIT indicators may be covered, during normal operation, if ready access for maintenance personnel is provided (see Appendix F).

3.5.6 Treatment and finish. All surfaces of the DRUH shall be treated and finished for protection against corrosion. Dissimilar metal combinations shall be selected or protected to preclude corrosion. The exterior color shall be lusterless Army green. The exterior finish shall withstand exposure to the operational and storage environments, and NBC contamination and decontamination. The exterior finish shall permit damaged areas to be "touched up" in the field.

3.5.7 Marking and identification. The identification plate shall be in accordance with Figure 3. All equipment, parts and assemblies shall be legibly and permanently marked.

3.5.8 Grounding. Ground connection to the chassis and to other mechanical parts shall not be made to complete electrical circuits, but only to eliminate high-potential AC points. The DRUH shall be designed so that a DC power return circuit cannot be completed through the DRUH chassis to a grounded vehicle chassis.

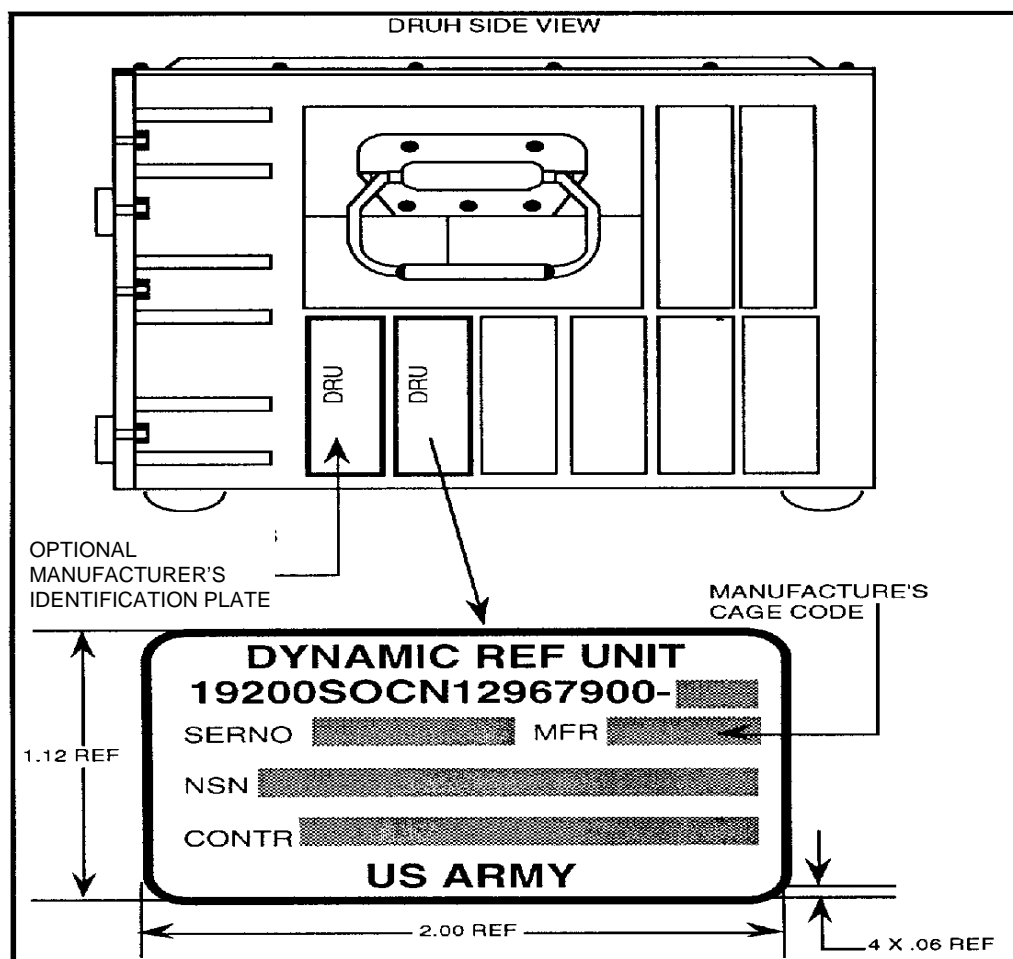

- NOTES:
1. Background color, black.
  2. Character color, natural aluminum.
  3. Characters shall be 0.125 inch high.

Figure 3. Identification plate.

3.5.9 Interchangeability. The DRUH shall be interchangeable from any host system to any other host system without requiring hardware changes, calibration procedures, vehicle driving constraints, or unscheduled ZUPTs.

Design tolerance shall permit parts, subassemblies and assemblies to be used in their parent assemblies without regard to the source of supply or manufacturer. Parts, subassemblies and assemblies having the full range of dimensions and characteristics permitted by the specification governing the part, subassembly or assembly shall be usable as replacement

items without selection and without deviation from the specified performance requirements of the parent item.

3.5.10 Safety. The DRUH shall provide fail-safe features for safety of personnel during the installation, operation, maintenance, and repair or interchanging of a DRUH or components thereof.

3.5.10.1 Environmental safety. The DRUH shall not produce nor emit toxic by-products capable of damaging the health of operators or their environment.

3.5.11 Human performance/human engineering. Human performance and human engineering design principles shall be applied to the DRUH to achieve simple and error free operation and maintenance. Equipment markings shall be legible. The DRUH shall be liftable, installable and removable, using the handles, by no more than two people wearing arctic or NBC protective clothing.

3.5.12 Useful life. The DRUH shall have a useful life of at least 15 years under any combination of operation and storage.

3.5.13 Workmanship. Electronics equipment shall be properly cleaned, positioned and protected from any foreign material that might detract from the intended operation, function, or appearance of the equipment.

### 3.6 Operating requirements.

3.6.1 General. Unless otherwise specified, operating requirements apply to performance under any and all combinations of conditions and environments specified herein.

3.6.2 Accuracy. Accuracy requirements, when GPS aided, assume the DRUH is receiving GPS positions accurate to 16 meters SEP, or better, at a minimum rate of one per minute.

The horizontal position and altitude accuracy requirements apply when the DRUH has completed Accelerated Align, Static Align, Interrupted Static Align with one travel period  $\leq 4$  minutes, or Dynamic Align; or when the following conditions are applicable:

- a. A position update is performed after interrupted Static Align (3.3.8.5) was completed with more than one vehicle travel period, or
- b. A position update is performed after interrupted Static Align was completed when travel time between vehicle stops exceeded four minutes.

After completion of Static Align or Dynamic Align, positioning and azimuth accuracy may vary as a function of the maximum Static Align Time specified in configuration data. Position and azimuth accuracy requirements, specified herein, shall be met when the specified maximum Static Align Time is 15 minutes or greater.

Horizontal position and altitude accuracy requirements are relative to the previous host position update and do not include errors in host input position update coordinates. If position is initialized from GPS, with no host update, accuracy requirements are relative to "absolute" WGS 84 positions as shifted to the selected datum.

Horizontal position and altitude accuracy requirements apply when the DRUH has been nominally stationary for 30 seconds and longer.

Accuracy requirements shall be met, without requiring host realign actions, during and after host operations such as: travel, deployment, antenna erection, stowing and pointing; radar activation; and weapon loading, aiming, firing and stowing.

3.6.2.1 Horizontal position accuracy. Horizontal position errors shall not exceed the values given in Table XIX for the specified aiding conditions, latitude ranges, and distances traveled from the last position update. No more than 1.0 percent of the radial errors shall exceed the value in the 99 percent column.

Table XIX. Horizontal position accuracy.

AIDING AVAILABLE	HORIZONTAL ERROR (meters)		
	LATITUDE 65°S - 65°N		65°S - 80°S 65°N - 84°N
	CEP	99 percent	CEP
VMS aided, no GPS, 60 min ZUPTs DIST ≤ 4,000 m DIST > 4,000 m	10.0 0.0025 x DIST	26.0 0.0065 x DIST	10.0 0.0025 x DIST
VMS aided, no GPS, 10 min ZUPTs DIST ≤ 27,000 m DIST ≤ 63,900 x Cos(Lat) m	18.0 n/a	47.0 n/a	n/a 18.0
No VMS, no GPS, 4 min ZUPTs DIST ≤ 27,000 DIST ≤ 63,900 x Cos(Lat) m	18.0 n/a	47.0 n/a	n/a 18.0
GPS aided, any distance	10.0	47.0	10.0

3.6.2.2 Altitude accuracy. Altitude errors shall not exceed the values given in Table XX for the specified aiding conditions, latitude range, and distances traveled from the last altitude

update. No more than 1.0 percent of altitude errors shall be outside the range in the 99 percent column.

Table XX. Altitude accuracy.

AIDING AVAILABLE	ALTITUDE ERROR (meters)	
	LATITUDE 80°S - 84°N	
	PE	99 percent
VMS aided, no GPS, 60 min ZUPTS DIST ≤ 10,000 m DIST > 10,000 m	6.7 0.00067 x DIST	±26.0 ±.0026 x DIST
VMS aided, no GPS, 10 min ZUPTS DIST ≤ 35,000 m	10.0	±39.0
No VMS, no GPS, 4 min ZUPTS DIST ≤ 35,000 m	10.0	±39.0
GPS aided, any distance	10.0	±39.0

3.6.2.3 Attitude accuracy. Attitude errors shall not exceed the values given in Table XXI for the specified conditions and latitude ranges. No more than 1.0 percent of attitude errors shall be outside the ranges in the 99 percent column.

Table XXI. Pointing device attitude accuracy.

PARAMETER & ALIGN TYPE	ATTITUDE ERROR (mils)		
	LATITUDE 65°S-65°N		65°S-80°S & 65°N-84°N
	PE	99 percent	PE
Initial Azimuth After: Accelerated Align	0.1 (see note below)		0.1 (see note below)
Static Align		±2.6	0.283 x Secant(Lat)
Dynamic Align	0.67	±2.6	0.67
	0.67		
Survey Azimuth:	0.67	±2.6	0.283 x Secant(Lat)
Pitch:	0.34	±1.3	0.34
Roll/Cant:	0.34	±1.3	0.34

**NOTE:** RMS error relative to the Stored Heading value

Initial azimuth requirements apply at completion of the specified align type. Survey azimuth, pitch, and roll/cant requirements apply at any time during missions of up to 24 hours in duration, commencing at align completion.

Attitude accuracy requirements stated herein shall be met at any DRUH case orientation.

Attitude accuracy requirements apply to Pointing Device attitudes and assume that the DRUH has been accurately aligned to the Pointing Device. Pointing Device Geodetic or Grid Azimuth may be in error when the pointing device's pointing axis is within 5 degrees of vertical.

Vehicle Attitudes shall be within 18 mils PE.

3.6.2.4 Transport accuracy. While in Air Transport, prior to takeoff, horizontal position and altitude accuracy shall be as specified in 3.6.2.1 and 3.6.2.2, respectively.

While in Air Transport, after takeoff, or Marine Transport and usable GPS aiding is not available, horizontal position error shall not exceed 1 nmi/hr CEP per hour of transport time and altitude error is not specified.

While in Marine or Air Transport and usable GPS aiding is available, horizontal position and altitude accuracy shall be as specified in 3.6.2.1 and 3.6.2.2, respectively.

Upon completion of Marine or Air Transport and acceptance of a host or GPS position update, horizontal position, altitude, and attitude accuracy shall be as specified in 3.6.2.1 - 3.6.2.3, respectively.

3.6.2.5 Angular rate accuracy. In Survey, Pointing Device Grid or Geodetic Azimuth rate, Pitch rate, and Roll rate errors shall not exceed:

- a. 0.5 mil per second RMS for angular rates in the range of -356 to +356 mils per second. Non-linearity shall not exceed 1 percent.
- b. 2.5 percent of the instantaneous rate RMS for angular rates in the ranges of -3276.8 to -356 and +356 to +3276.8 mils per second.

3.6.2.6 Data delay. Data delay shall be the sum of data latency and data staleness.

3.6.2.6.1 Data latency. Data latency is the delay between the time a sensor is strobed and the availability of data in the output buffers. Data latency shall not exceed: 10 msec for pointing device attitude data; 20 msec for pointing device attitude rate data; and 60 msec for position data.

3.6.2.6.2 Data staleness. Data staleness is the delay between the time the processed DRUH data are available in the output buffers and the time transmission of the message, containing that data, is completed. Data staleness shall not exceed the maximum response time specified for each message in Appendix A.

### 3.6.3 Reaction time.

3.6.3.1 Static align time. After application of power or acceptance of a RESTART command, Static Align shall be completed within the time specified in configuration data when the vehicle is nominally stationary for the entire period.

If Static Align is interrupted, reaction time may increase in accordance with 3.3.8.5.

3.6.3.2 Accelerated align time. Accelerated Align shall be completed within 60 seconds after receipt of the STORED HEADING command or after application of power if the DRUH previously was shut down with a STORED HEADING SHUTDOWN command.

Time to achieve VMS aiding following Accelerated Align shall be in accordance with 3.3.8.3.1.

3.6.3.3 Dynamic align time. After application of power, Dynamic Align shall be completed within the Static Align Time specified in configuration data. The nominal conditions for dynamic align are: vehicle speed greater than or equal to 20 Km/Hr; turns are performed along the vehicle trajectory; and usable GPS data, with EPE less than or equal to 16 meters, is available for the entire dynamic align period. If, at the end of the nominal dynamic align time, the estimated azimuth error is less than or equal to 3.0 mils PE, but greater than 1.0 mil PE, the dynamic align time may be extended up to 12 additional minutes. Dynamic align time may be extended if GPS data are invalid or are interrupted for periods greater than 60 seconds.

3.6.4 Mission length and duration. DRUH survey missions may range from 0 to 100 Km in length and 15 minutes to 24 hours in duration. Position updates at distances traveled no shorter than those specified in Table XIX and Table XX are permitted to maintain accuracy requirements when usable GPS aiding is not available.

### 3.6.5 Alignment conditions.

3.6.5.1 Off level. The DRUH shall perform as specified herein when mounted in any orientation.

3.6.5.2 Base motion while stationary. The DRUH shall perform as specified herein when the host vehicle, while nominally stationary, is subject to wind buffeting, normal crew movement, engine vibration, vibration from engine/generator sets, and other sources of motion usually found on the battlefield.

3.6.5.3 Base motion while in motion. The DRUH shall perform interrupted Static Align and Dynamic Align as specified herein when the host is subject to vehicle dynamics for Survey conditions.

### 3.6.6 Survey conditions.

3.6.6.1 Vehicle dynamics. The DRUH shall perform as specified herein when operated within the following dynamic conditions:

- a. In ground vehicles, horizontal velocity within the range of 0 to 80 miles per hour. While being transported by helicopter, ground speed within the range of 0 to 200 knots.
- b. In ground vehicles, vertical velocity within the range of 0 to 15 miles per hour up or down. While being transported by helicopter, vertical speed within the range of 0 to 2400 ft/min.
- c. Acceleration (excluding shock and vibration) within the range of 0 to 1.5g (not including gravitational acceleration) in any direction due to vehicle starting, stopping and turning.
- d. Vehicle pitch within the range of -40 to +40 degrees. Vehicle cant/roll within the range of -40 to +40 degrees.
- e. Angular velocities within the range of 0 to 200 degrees per second around any axis.
- f. Angular accelerations within the range of 0 to 6000 degrees per second<sup>2</sup> around any axis.
- g. Shock and vibration generated by the transporting vehicle, which may be a tracked vehicle, tracked trailer, wheeled vehicle, wheeled trailer, helicopter, or helicopter lift of a palletized system.
- h. Drop shock sustained when a helicopter lifted pallet is set down on the ground.

- i. Variations in odometer scale factor and direction of travel alignment resulting from changes in vehicle tire pressure, loading, wheel/track slippage, turns, crabbing, terrain conditions, and any other conditions normally encountered by a host vehicle. No external calibrations of odometer scale factor and direction of travel alignment shall be required.

3.6.6.2 Deployment. In addition to operating when subjected to the above vehicle dynamics, the DRUH shall perform as specified herein when operated under the following conditions:

- a. Shock and vibration generated by weapon firing.
- b. Rotation and elevation of a pointing device. When mounted to a pointing device, the DRUH shall be capable of being elevated through an angle of 105 degrees or rotated 360 degrees in azimuth when the pointing device is erected.

4. VERIFICATION

Table XXII. Requirement/verification cross-reference matrix

METHOD OF VERIFICATION N/A - NOT APPLICABLE 1 - ANALYSIS 2 - DEMONSTRATION 3 - EXAMINATION 4 - TEST						CLASSES OF VERIFICATION A - DESIGN VERIFICATION B - FIRST ARTICLE C - ACCEPTANCE			
SECTION 3 REQUIREMENT	VERIFICATION METHOD					VERIFICATION CLASS			SECTION 4 VERIFICATION
	N/A	1	2	3	4	A	B	C	
3.1		X	X	X	X	X			4.5
3.2			X	X	X		X		4.6
3.3	X								
3.3.1			X			X			4.8.9
3.3.2			X			X			4.8.9
3.3.3			X			X			4.8.9
3.3.4					X	X			4.8.9
3.3.4.1					X	X			4.8.9
3.3.4.2					X	X			4.8.9
3.3.4.3					X	X			4.8.9
3.3.4.4					X	X			4.8.9
3.3.4.5					X	X			4.8.9
3.3.5			X			X			4.8.9, 4.8.6.4
3.3.5.1			X			X			4.8.9, 4.8.6.4
			X			X	X		4.8.5
			X				X	X	4.8.2
3.3.5.2		X	X			X			4.8.9
3.3.6			X			X			4.8.9, 4.8.6.4
			X			X	X		4.8.5
			X				X	X	4.8.2
3.3.6.1		X	X			X			4.8.9
3.3.7			X			X			4.8.9, 4.8.6.4
			X			X	X		4.8.5
			X				X	X	4.8.2
3.3.7.1			X			X			4.8.9
3.3.7.2			X			X			4.8.9
3.3.7.2.1			X			X			4.8.9
3.3.7.3			X			X			4.8.9
3.3.7.3.1			X			X			4.8.9
3.3.7.4			X			X			4.8.9
3.3.7.4.1			X			X			4.8.9, 4.8.6.4
			X			X	X		4.8.5
			X				X	X	4.8.2
3.3.7.5			X			X			4.8.9
3.3.7.5.1			X			X			4.8.9
3.3.7.5.2			X			X			4.8.9
3.3.7.5.3			X			X			4.8.9
3.3.7.5.4			X			X			4.8.9

Table XXII. Requirement/verification cross-reference matrix

METHOD OF VERIFICATION N/A - NOT APPLICABLE 1 - ANALYSIS 2 - DEMONSTRATION 3 - EXAMINATION 4 - TEST					CLASSES OF VERIFICATION A - DESIGN VERIFICATION B - FIRST ARTICLE C - ACCEPTANCE				
SECTION 3 REQUIREMENT	VERIFICATION METHOD				VERIFICATION CLASS			SECTION 4 VERIFICATION	
	N/A	1	2	3	4	A	B		C
3.3.7.5.5			X			X			4.8.9
3.3.7.5.6			X			X			4.8.9
3.3.7.5.7			X			X			4.8.9
3.3.7.5.7.1			X			X			4.8.9
3.3.7.5.7.2			X			X			4.8.9
3.3.7.5.7.3			X			X			4.8.9
3.3.7.5.7.4			X			X			4.8.9
3.3.7.5.8			X			X			4.8.9
3.3.7.5.9			X			X			4.8.9
3.3.8		X	X			X			4.8.9
3.3.8.1			X			X			4.8.9
3.3.8.2			X			X			4.8.9
3.3.8.2.1			X			X			4.8.9
3.3.8.2.2			X			X			4.8.9
3.3.8.2.3			X			X			4.8.9
3.3.8.2.4			X			X			4.8.9
3.3.8.3			X			X			4.8.9
3.3.8.3.1			X			X			4.8.9
3.3.8.4			X			X			4.8.9, 4.8.6.4
			X			X	X		4.8.5
			X				X	X	4.8.2
3.3.8.5			X			X			4.8.9
3.3.8.6			X			X			4.8.9
3.3.8.7			X			X			4.8.9, 4.8.6.4
			X			X	X		4.8.5
			X				X	X	4.8.2
3.3.8.8			X			X			4.8.9
3.3.8.9			X			X			4.8.9
3.3.8.10			X			X			4.8.9
3.3.8.11			X			X			4.8.9
3.3.9		X	X			X			4.8.9
			X				X		4.8.9
3.3.9.1			X			X			4.8.9
3.3.9.2			X			X			4.8.9
3.3.9.3		X	X			X			4.8.9
3.3.9.4	X								
3.3.9.4.1		X	X			X			4.8.9
3.3.9.4.2		X	X			X			4.8.9
3.3.9.4.3		X	X			X			4.8.9
3.3.9.4.3.1		X	X			X			4.8.9
3.3.9.4.3.2			X			X			4.8.9
3.3.9.4.3.3			X			X			4.8.9
3.3.10			X			X			4.8.9

Table XXII. Requirement/verification cross-reference matrix

METHOD OF VERIFICATION N/A - NOT APPLICABLE 1 - ANALYSIS 2 - DEMONSTRATION 3 - EXAMINATION 4 - TEST					CLASSES OF VERIFICATION A - DESIGN VERIFICATION B - FIRST ARTICLE C - ACCEPTANCE				
SECTION 3 REQUIREMENT	VERIFICATION METHOD				VERIFICATION CLASS			SECTION 4 VERIFICATION	
	N/A	1	2	3	4	A	B		C
3.3.10.1			X			X			4.8.9
3.3.10.2			X			X			4.8.9
3.3.10.3			X			X			4.8.9
3.3.10.4			X			X			4.8.9
3.3.10.5		X	X			X			4.8.9
3.3.11			X			X			4.8.9
3.3.11.1			X			X			4.8.9
3.3.11.2			X			X			4.8.9
3.3.12			X			X			4.8.9
3.3.13	X								
3.3.13.1				X		X	X	X	4.8.1
3.3.13.1.1		X	X			X			4.8.9
3.3.13.2			X			X			4.8.9
3.3.13.3			X			X			4.8.9
			X				X	X	4.8.2
3.3.13.3.1			X			X			4.8.9
			X				X	X	4.8.2
3.3.13.3.2		X	X			X			4.8.9
3.3.13.3.3			X			X			4.8.9
			X				X	X	4.8.2
3.3.13.3.4			X			X			4.8.9
			X				X	X	4.8.2
3.3.13.4	X								
3.3.13.4.1		X				X			4.8.9
3.3.13.4.2		X				X			4.8.9
3.3.13.4.3		X			X	X			4.8.9
			X				X	X	4.8.2
3.3.13.4.4		X			X	X			4.8.9
			X				X	X	4.8.2
3.3.13.4.4.1		X			X	X			4.8.9
			X				X	X	4.8.2
3.3.13.4.5			X			X			4.8.9
			X				X	X	4.8.2
3.3.13.4.6		X	X			X			4.8.9
			X				X	X	4.8.2
3.3.13.5		X	X			X			4.8.9
			X				X	X	4.8.2
3.3.13.6		X	X			X			4.8.9
			X				X	X	4.8.2
3.3.13.6.1			X			X			4.8.9
			X				X	X	4.8.2
3.3.13.6.2			X			X			4.8.9
			X				X	X	4.8.2
3.3.13.6.3		X	X			X			4.8.9
			X				X	X	4.8.2

Table XXII. Requirement/verification cross-reference matrix

METHOD OF VERIFICATION N/A - NOT APPLICABLE 1 - ANALYSIS 2 - DEMONSTRATION 3 - EXAMINATION 4 - TEST					CLASSES OF VERIFICATION A - DESIGN VERIFICATION B - FIRST ARTICLE C - ACCEPTANCE				
SECTION 3 REQUIREMENT	VERIFICATION METHOD				VERIFICATION CLASS			SECTION 4 VERIFICATION	
	N/A	1	2	3	4	A	B		C
3.3.13.7		X	X			X			4.8.9
			X				X	X	4.8.2
3.3.14				X		X	X	X	4.8.1
3.3.15		X	X			X	X		4.8.11
3.4	X								
3.4.1	X								
3.4.1.1					X	X	X		4.8.4.4, 4.8.4.5
3.4.1.2					X	X	X		4.8.4.4, 4.8.4.5
3.4.2					X	X	X		4.8.4.6
3.4.3					X	X			4.8.4.3
3.4.4					X	X			4.8.4.8
3.4.5					X	X			4.8.4.9
3.4.6					X	X			4.8.4.10
3.4.7					X	X			4.8.4.7
3.4.8					X	X	X		4.8.4.11
3.4.9					X	X			4.8.4.12
3.4.10					X	X			4.8.4.13
3.4.11	X								
3.4.11.1					X	X			4.8.6.3
3.4.11.2					X	X	X		4.8.4.14.1
3.4.11.3					X	X	X		4.8.4.14.2
3.4.12					X	X	X		4.8.4.15
3.4.13					X	X	X		4.8.4.16
3.4.14					X	X			4.8.4.17
3.4.15					X	X			4.8.4.18
3.4.16					X	X			4.8.4.20
3.4.17	X								
3.4.17.1		X	X			X			4.8.4.19
3.4.17.2		X	X			X			4.8.4.19
3.4.17.3		X	X			X			4.8.4.19
3.4.17.4			X			X			4.8.4.19
3.4.18		X			X	X			4.8.10
3.5	X								
3.5.1		X	X			X			4.8.6
3.5.2	X								
3.5.2.1			X			X			4.8.7
3.5.2.2		X		X		X			4.8.7
3.5.2.3		X				X			4.8.7
3.5.3		X				X			4.8.9
				X		X	X	X	4.8.1
3.5.4				X		X	X	X	4.8.1
3.5.5			X			X			4.8.9
3.5.6		X				X			4.8.9

Table XXII. Requirement/verification cross-reference matrix

METHOD OF VERIFICATION N/A - NOT APPLICABLE 1 - ANALYSIS 2 - DEMONSTRATION 3 - EXAMINATION 4 - TEST					CLASSES OF VERIFICATION A - DESIGN VERIFICATION B - FIRST ARTICLE C - ACCEPTANCE				
SECTION 3 REQUIREMENT	VERIFICATION METHOD				VERIFICATION CLASS			SECTION 4 VERIFICATION	
	N/A	1	2	3	4	A	B		C
				X		X	X	X	4.8.1
3.5.7				X		X	X	X	4.8.1
3.5.8		X		X		X			4.8.9
3.5.9		X	X			X			4.8.9
3.5.10		X		X		X			4.8.9
				X		X	X	X	4.8.1
3.5.10.1		X				X			4.8.9
3.5.11		X		X		X			4.8.3
3.5.12		X				X			4.8.9
3.5.13				X		X	X	X	4.8.1
3.6	X								
3.6.1	X								
3.6.2	X								
3.6.2.1		X	X			X			4.8.9, 4.8.6.4
			X			X	X		4.8.5
			X				X	X	4.8.2
3.6.2.2		X	X			X			4.8.9, 4.8.6.4
			X			X	X		4.8.5
			X				X	X	4.8.2
3.6.2.3		X	X			X			4.8.9, 4.8.6.4
			X			X	X		4.8.5
			X				X	X	4.8.2
3.6.2.4		X	X			X			4.8.9
3.6.2.5		X	X			X			4.8.9
3.6.2.6	X								
3.6.2.6.1		X			X	X			4.8.9
3.6.2.6.2		X			X	X			4.8.9
3.6.3	X								
3.6.3.1		X	X			X			4.8.9
3.6.3.2		X	X			X			4.8.9
3.6.3.3		X	X			X			4.8.9
3.6.4		X	X			X			4.8.9
3.6.5	X								
3.6.5.1		X	X			X			4.8.9
3.6.5.2		X	X			X			4.8.9
			X			X	X		4.8.5
3.6.5.3		X	X			X			4.8.9
			X			X	X		4.8.5
3.6.6	X								
3.6.6.1		X	X			X			4.8.9
			X			X	X		4.8.5
3.6.6.2		X	X			X			4.8.9

Table XXII. Requirement/verification cross-reference matrix

METHOD OF VERIFICATION					CLASSES OF VERIFICATION				
N/A - NOT APPLICABLE					A - DESIGN VERIFICATION				
1 - ANALYSIS					B - FIRST ARTICLE				
2 - DEMONSTRATION					C - ACCEPTANCE				
3 - EXAMINATION									
4 - TEST									
SECTION 3 REQUIREMENT	VERIFICATION METHOD				VERIFICATION CLASS			SECTION 4 VERIFICATION	
	N/A	1	2	3	4	A	B	C	
			X			X	X		4.8.5

4.1 Verification methods. Methods utilized to accomplish verification include:

- a. Analysis. An element of verification that utilizes established technical or mathematical models or simulations, algorithms, charts, graphs, circuit diagrams, or other scientific principles and procedures to provide evidence that stated requirements were met.
- b. Demonstration. An element of verification which generally denotes the actual operation, adjustment, or re-configuration of items to provide evidence that the designed functions were accomplished under specific scenarios. The items may be instrumented and quantitative limits of performance monitored.
- c. Examination. An element of verification and inspection consisting of investigation, without the use of special laboratory appliances or procedures, of items to determine conformance to those specified requirements which can be determined by such investigations. Examination is generally nondestructive and typically includes the use of sight, hearing, smell, touch, and taste; simple physical manipulation; mechanical and electrical gauging and measurement; and other forms of investigation.
- d. Test. An element of verification and inspection that generally denotes the determination, by technical means, of the properties or elements of items, including functional operation, and involves the application of established scientific principles and procedures.

4.2 Verification classifications. The verification types specified herein are classified as follows:

- a. Design Verification (see 4.5)
- b. First article (see 4.6)
- c. Acceptance (see 4.7)

4.3 Verification conditions. Unless otherwise specified, test conditions shall be as specified in approved test plans and procedures.

4.4 Failure and rejection criteria. The following failure and rejection criteria shall be used during verification unless otherwise specified.

The term failure includes: part or component deterioration or breakage; damage evident from equipment inspection; non-conformance to the requirements specified for performance, operational, or physical characteristics; and deviations beyond the tolerances established in this specification, in the approved test procedures, or in the equipment design.

The following shall be classified as failures:

- a. Adjustment, replacement, or repair of a part or assembly.
- b. The need to reprogram the DRUH.
- c. Any Northing or Easting error within a static survey run exceeding 2 meters/hour (see note below).
- d. Any altitude error within a static survey run exceeding 4 meters/hour (see note below).
- e. Any BIT failure indication(s).
- f. Failure to complete alignment or necessity of restarting alignment.

**NOTE:** These values may vary depending on the contractor's test equipment and DRUH mechanization. Any variation must be approved by the Government.

Upon occurrence of a failure, or whenever it becomes evident that the DRUH will not meet a specified requirement, verification shall be stopped.

#### 4.5 Design verification.

4.5.1 Design verification routine. Design verification units shall be subjected to verification of all requirements identified in Table XXII in accordance with the specified section 4 paragraph.

4.5.2 Sample size. Unless otherwise specified, each verification shall be performed on one unit. All units submitted

for design verification shall undergo physical examination, operational demonstration, and operational low and high temperature testing. Three units shall undergo low and high storage temperature testing. Two units shall be used in Reliability Demonstration. Units used for Maintainability Demonstration shall be in accordance with 4.8.7.

4.5.3 Failures. Design verification must be completed without failure. The allowable failures to pass Reliability Demonstration shall be in accordance with the approved procedure.

#### 4.6 First article.

4.6.1 First article routine. As determined by the Government, the first article sample may be subjected to any or all of the examinations, demonstrations and tests specified herein and be inspected for compliance with any or all requirements of the applicable drawings.

Unless otherwise specified in the contract or purchase order or stipulated by the Contracting Officer, the first article sample shall be subjected to verification of all requirements identified in Table XXII in accordance with the specified section 4 paragraph. All units selected for first article Inspection shall have passed acceptance.

4.6.2 Sample size. Unless otherwise specified, one unit shall undergo each first article verification. Three units shall undergo low and high temperature testing. All first article units shall undergo operational demonstration.

4.6.3 Failures. If any sample unit fails to comply with any applicable requirement, the first article sample shall be rejected.

#### 4.7 Acceptance.

4.7.1 Acceptance routine. Units shall be subjected to verification of all requirements identified in Table XXII in accordance with the specified section 4 paragraph.

4.7.1.1 Sample size. All units shall undergo each acceptance inspection.

4.7.2 Failures. A unit must pass all acceptance verifications to be accepted. All failures shall be reported and analyzed.

4.7.3 Alternative inspection provisions. Unless otherwise specified, alternative acceptance procedures, methods, or equipment may be proposed to the Government by the contractor.

4.8 Methods of verification.

4.8.1 Physical examination. The equipment shall be examined for the following defects:

- a. Configuration record incomplete or inaccurate.
- b. Assemblies, parts or components missing or damaged.
- c. Materials that don't meet performance requirements or are damaged.
- d. Protective devices missing or damaged.
- e. System interfaces which don't meet specified interface characteristics.
- f. Treatment and painting missing or damaged.
- g. Assembly incomplete or incorrect.
- h. Identification marking missing, incomplete or not legible.
- i. Parts, sub-assemblies and assemblies contaminated by foreign substances.

The presence of one or more defect(s) shall constitute a failure of the examination.

4.8.2 Acceptance quality tests. Acceptance Quality Tests shall simulate normal operational conditions and verify BIT, modes of operating, updating of parameters, communication interfaces, VMS interface, discrettes, power supply outputs, correct operation with high and low input voltages, turn-on/turn-off and functional characteristics by measurement. Failure to meet specified values for any monitored parameter, any out of tolerance condition, or malfunction, shall constitute failure of the test and rejection of the DRUH.

Acceptance Quality Tests shall include azimuth alignment and pitch and roll accuracy tests. The unit shall be rejected if the azimuth error exceeds 1.0 mil RMS or if the pitch error or roll error exceeds 0.5 mil RMS. Data sample size(s) shall be as specified in the contract or order (see 6.2). No data shall be excluded from a RMS calculation.

Acceptance Quality Tests shall include position drift and survey azimuth accuracy tests.

4.8.3 Human factors examination. The equipment shall be examined for compliance with the requirements of 3.5.11. Equipment markings shall be viewed for legibility. The DRUH shall be installed in a Paladin, or simulated Paladin DRUH installation, using the handles and arctic and NBC clothing. Inability to read equipment markings, or lift, install or remove the DRUH shall constitute failure of this test.

#### 4.8.4 Environmental tests.

4.8.4.1 General. Where a test calls for a simulated survey mission, the DRUH shall be operated without GPS and VMS aiding with four minute simulated travel periods between 30 second ZUPTs.

The DRUH shall be operated for equal time periods with the input supply voltage at the nominal level, the lowest specified limit, and the highest specified limit.

During a simulated survey mission the DRUH shall be tested for: normal BIT, ALERT and STATUS indications; horizontal position and altitude values within approved limits; and azimuth within approved limits.

Failure to meet the specified value of any parameter shall constitute failure of the test.

4.8.4.2 Pre and post testing. Prior to and after each test, where the equipment is tested in a static mode (chamber and mechanical tests), a series of tests shall be performed to verify proper operation of the equipment. The equipment shall be inspected for physical damage, loose hardware, degradation of materials or any other defect after each test. Should the system set up remain the same from one major test to the next, the post-test verification test may serve as the pre-test verification test for the next major test.

4.8.4.3 Altitude. The DRUH shall be subjected to non-operating and operating low pressure (altitude) tests. A simulated altitude of 40,000 feet shall be maintained for 1 hour during the non-operating test. The operating test shall consist of a one hour simulated survey mission at a simulated altitude of 10,000 feet. The rate of altitude change shall not exceed 10 meters/second. MIL-STD-810, Method 500.2, procedures I (non-operating) and II (operating) provide guidance for altitude testing.

4.8.4.4 High temperature. The DRUH shall be subjected to storage and operating high temperature tests. The storage test shall be conducted at a temperature of +160°F for a minimum of 168 hours. The operating test shall be conducted using daily temperature cycles representing induced conditions in a hot climate. Precise humidity control is not required. The operating test duration shall be a minimum of 72 hours. Simulated survey missions shall be performed whenever the chamber temperature is +140°F or lower. The same sample shall be used for the storage and operating tests. The storage test shall be performed first. MIL-STD-810, Method 501.3, procedures I and II provide guidance for high temperature testing.

4.8.4.5 Low temperature. The DRUH shall be subjected to storage and operating low temperature tests. The storage test duration shall be a minimum of 72 hours at a stabilized temperature of -60°F. The operating test shall include a 24-hour non-operational cold soak at -60°F, followed by temperature stabilization at -50°F for a 6 hour simulated DRUH survey mission. The same sample shall be used for the storage and operating tests. The storage test shall be performed first. MIL-STD-810, Method 502.3, Procedures I and II provide guidance for low temperature testing.

4.8.4.6 Temperature shock. The DRUH shall be subjected to a low-high-low-high-low-high-low sequence of ambient temperatures. The low and high temperatures shall be -60°F and +160°F, respectively. The DRUH temperature shall be stabilized at each ambient temperature prior to changing the ambient temperature. When changing to a new ambient temperature, the ambient temperature shall be changed within 5 minutes. MIL-STD-810, Method 503.3 provides guidance for temperature shock testing.

4.8.4.7 Solar radiation. The DRUH shall be subjected to a minimum of three, 24-hour, solar radiation and temperature cycles. The diurnal temperature and solar radiation cycles shall represent exposure in a hot-dry climate and shall be applied simultaneously. The DRUH shall be operated during a 6 hour simulated survey mission at the peak temperature for each of the diurnal cycles. MIL-STD-810, Method 505.3, Procedure I provides guidance for solar radiation testing.

4.8.4.8 Humidity. The DRUH shall be subjected to a minimum of 10, 24-hour, temperature and humidity cycles. The relative humidity shall be 95 percent ±5 percent. The temperature cycle shall be:

TEMPERATURE (°F)		DURATION
START	END	(Hours)
86	140	2
140	140	6
140	86	8
86	86	8

The DRUH shall be operated in simulated survey missions throughout the last hour of the fifth and tenth cycles, while maintaining current chamber conditions. MIL-STD-810, Method 507.3, Procedure III provides guidance for humidity testing.

4.8.4.9 Snow. A snow test shall be performed using a suitable environmental chamber or climatic test area to show that the DRUH operates in snow in accordance with 3.4.5. The DRUH shall be operated in a simulated survey mission during the last hour of the test.

4.8.4.10 Icing. The DRUH shall be subjected to two cycles of Icing/Freezing Rain testing. In cycle one, the DRUH shall be exposed to rain spray until a minimum of 6 mm of glaze ice has accumulated on all sides and the top surface. After the ice has accumulated, the ambient temperature shall be adjusted to +21°F and the DRUH operated in a simulated survey mission for a minimum of two hours. Cycle two shall be similar except the minimum ice accumulation shall be 13 mm. MIL-STD-810, Method 521.1, Procedure I provides guidance for Icing/Freezing Rain testing.

4.8.4.11 Washdown. The DRUH shall be exposed to a water stream from a 1-inch diameter nozzle fed by a pressure of 50 ±5 pounds per square inch for a period of 30 minutes. The stream shall be directed onto each face, except the DRUH mounting surface, of the DRUH from a distance of 3 feet, for equal periods. At the start of the test the DRUH temperature shall be at least 18°F higher than the water temperature. Only the specified mating connectors or cap (J3) are permitted to cover connectors. Failure to operate as specified or evidence of damage or leakage shall constitute failure of the test.

4.8.4.12 Salt fog. The DRUH shall be subjected to a minimum of three cycles of exposure to salt fog using the conditions specified in 3.4.9. A cycle shall consist of exposure to the salt fog for 24 hours, followed by 24 hours of drying at room temperature. The DRUH shall be operated in a simulated survey mission during the last hour of each of the drying out cycles. MIL-STD-810, Method 509.3 provides guidance for salt fog testing.

4.8.4.13 Fungus. The DRUH shall be exposed to fungi, of the types specified in 3.4.10, for a minimum of 90 days. Suitable

controls shall be used to verify the fungi are viable throughout the test. If the DRUH is a sealed unit, it may remain sealed throughout the test. MIL-STD-810, Method 508.4 provides guidance for fungus testing.

#### 4.8.4.14 Shock.

4.8.4.14.1 Functional. The DRUH shall be subjected to a minimum of three shock pulses in each direction in each of three orthogonal axes (minimum of 18 shock pulses, total). The shock pulse peak amplitude shall be 40 g with a duration of 6-9 msec. The DRUH shall be operating in Survey when the shock pulses are applied. The DRUH shall be operated in a simulated survey mission after the six shock pulses have been applied to each axis. MIL-STD-810, Method 516.4 Procedure I provides guidance on functional shock testing.

4.8.4.14.2 Bench handling. The DRUH shall be subjected to a series of drops simulating the impacts that might be encountered in servicing. The DRUH shall be pivoted around all edges and dropped on all surfaces that could be impacted during servicing. MIL-STD-810, Method 516.4, Procedure VI provides guidance on bench handling testing.

4.8.4.15 Vibration. The DRUH shall be subjected to vibration testing using the profiles and durations specified in Appendix E. During exposure periods the DRUH shall be operating in Survey and ZUPTs shall not be performed. The procedure for verification of the performance (accuracy) criteria shall be detailed in the Government approved test procedures. MIL-STD-810, Method 514.4, Category 8, Procedure I provides guidance on vibration testing.

4.8.4.16 EMI-EMC. The DRUH shall be tested for compliance with the requirements of 3.4.13 in accordance with MIL-STD-462.

4.8.4.17 Electrostatic discharge. The DRUH shall be connected to an electrostatic generator through a 1000 pf high-voltage cable. After being charged to a potential difference of 300,000 volts, the DRUH shall be discharged through a 500 Ohm resistor. The DRUH shall be subjected to a total of 30 charge/discharge cycles using both positive and negative charging polarities and at least 3 different discharge points. The DRUH shall not be damaged and shall operate as specified in 3.4.14, after exposure to the charge/discharge cycles.

4.8.4.18 Lightning. The DRUH shall be installed in a lightning discharge test facility and subjected to 10 lightning pulses, approximating Figure 2, at a distance of 10 meters. The DRUH shall be operating in Survey when subjected to half the

strikes and inactive for the remaining exposures. The DRUH shall not be damaged and shall operate as specified in 3.4.15 after exposure to the lightning pulses.

4.8.4.19 NBC survivability. The DRUH shall be analyzed or tested for conformance with the requirements in 3.4.17. The following conditions apply:

- a. Exterior surfaces are uniformly and separately contaminated with:
  - (1). Ten g/m<sup>2</sup> of thickened droplets of soman (GD) having a mass median diameter (MMD) of 2-5 mm.
  - (2). Ten g/m<sup>2</sup> of unthickened G-Agent (VX).
  - (3). Ten g/m<sup>2</sup> of unthickened mustard (HD).
  - (4). 10<sup>5</sup> spores/m<sup>2</sup> of biological agent 1-5 micrometers in size.
  - (5). Four g/m<sup>2</sup> of insoluble radioactive contaminants 37-200 micrometers in size and 185 GBq/m<sup>2</sup> gamma activity.
- b. Initial contamination levels on interior surfaces subject to contamination are a factor of 10 lower than on exterior surfaces in the absence of evidence to the contrary.
- c. Decontamination begins one hour after contamination. The decontamination process, excluding monitoring, lasts no longer than 75 minutes.
- d. Surface temperature is 30°C and exterior wind speed no greater than 1 m/sec.

Testing shall be conducted at facilities approved by the Government using accept/reject criteria as specified in the contract or order (see 6.2).

4.8.4.20 Explosive atmosphere. The DRUH shall be operated in an explosive fuel vapor and air atmosphere at a simulated test altitude of 10,000 feet and a temperature of +140°F. Ignition or explosion of the fuel vapor and air mixture shall constitute failure of the test. MIL-STD-810, Method 511.3, Procedure I provides guidance for explosive atmosphere testing.

4.8.5 Operational demonstration. The DRUH, installed in a wheeled vehicle, shall be tested for two missions over a Government approved test course. The time to traverse the test course shall be approximately 6 hours. In addition to the

initialization point, the test course shall have at least 12 survey control points, spaced approximately equally in time, for measurement of DRUH survey parameters. Static align shall be used for both missions. GPS aiding shall not be used. VMS aiding shall be used for one mission.

The following parameters shall be measured:

- a. Alignment time.
- b. Time and duration of each zero-velocity stop.
- c. Horizontal position, altitude, pointing device attitude (azimuth, pitch, roll) and distance traveled at the initialization point and each survey control point.
- d. DRUH BIT failure indications.

Using the above data: the intervals between required ZUPTS shall be computed; and the position, altitude, and pointing device attitude (azimuth, pitch, and roll) error characteristics shall be calculated.

A DRUH BIT failure indication or failure to meet: Align time requirements of 3.6.3.1; ZUPT interval requirements of 3.3.7.1 and 3.3.7.4.1; ZUPT duration requirements of 3.3.7.4; or accuracy requirements of 3.6.2.1, 3.6.2.2 or 3.6.2.3 shall constitute failure of the test.

#### 4.8.6 Reliability demonstration.

4.8.6.1 General. The DRUH shall be tested as specified herein. Accept and reject criteria shall be as specified in the contract or order (see 6.2). The upper and lower test MTBF shall be 4000 and 2000 hours respectively. The consumer's risk of accepting equipment with an actual MTBF below 2000 hours shall not exceed 0.3. The contractor shall report, analyze and determine corrective action for all failures that occur during the reliability demonstration. The contractor shall treat all failures as chargeable. The Government will score all failures. MIL-HDBK-781 provides guidance on reliability testing.

4.8.6.2 Test conditions and procedures. The reliability demonstration shall consist of chamber test and functional survey test cycles. One functional test cycle shall be performed for each six chamber cycles. The following performance parameters shall be measured and evaluated to determine if the DRUH is functioning properly:

- a. Horizontal Position.

- b. Altitude.
- c. Pointing Device Attitudes.
- d. Alignment Time.

4.8.6.3 Chamber test. The chamber test cycle shall be in accordance with Figure 4. The DRUH shall be operated, without GPS or VMS aiding, with four minute simulated travel periods between ZUPTs. The procedure for verification of the performance (accuracy) criteria shall be detailed in the Government approved test procedure.

- a. Power voltage. The input power voltage shall be varied and the DRUH turned on and off in accordance with Figure 4. When turn-on is required with the power voltage at 16.4 VDC, the power voltage may be adjusted above the minimum turn-on voltage, and then reduced to 16.4 VDC when the DRUH turns on.
- b. Gunfire shock. The DRUH shall be exposed to simulated gunfire shocks in accordance with Figure 4. The shock spectra shall be in accordance with Appendix E. An equal number of simulated shocks shall be applied in each axis. Shock spectrum tolerances shall be in accordance with Appendix E. The DRUH shall be operating in Survey when the shock pulses are applied. ZUPTs are permitted between shock pulses. Verify that BIT and STATUS indications are normal after application of the pulses. Verify that position and altitude readings are stable and that azimuth drift is acceptable.

A separate gunfire shock test may be conducted instead of applying the shocks during the chamber cycle. If a separate test is performed, the DRUH shall be subjected to 32 shock pulses in each axis, at the start of the reliability test. After completing the gunfire shock test, the normal sequence of functional survey tests and chamber cycles shall be initiated. The gunfire shock test shall be repeated each time 24 chamber cycles have been completed.

- c. Temperature. Temperature shall be cycled in accordance with Figure 4.
- d. Vibration. The DRUH shall be subjected to the reliability vibration profiles contained in Appendix E, for 15 minutes periods, at the intervals indicated in Figure 4. The DRUH shall be vibrated for equal amounts of time in the vertical and longitudinal axes. In each axis, the DRUH shall be

vibrated for 50 percent of the time using the CUCV profile and 10 percent of the time using each of the five M109A6 profiles.

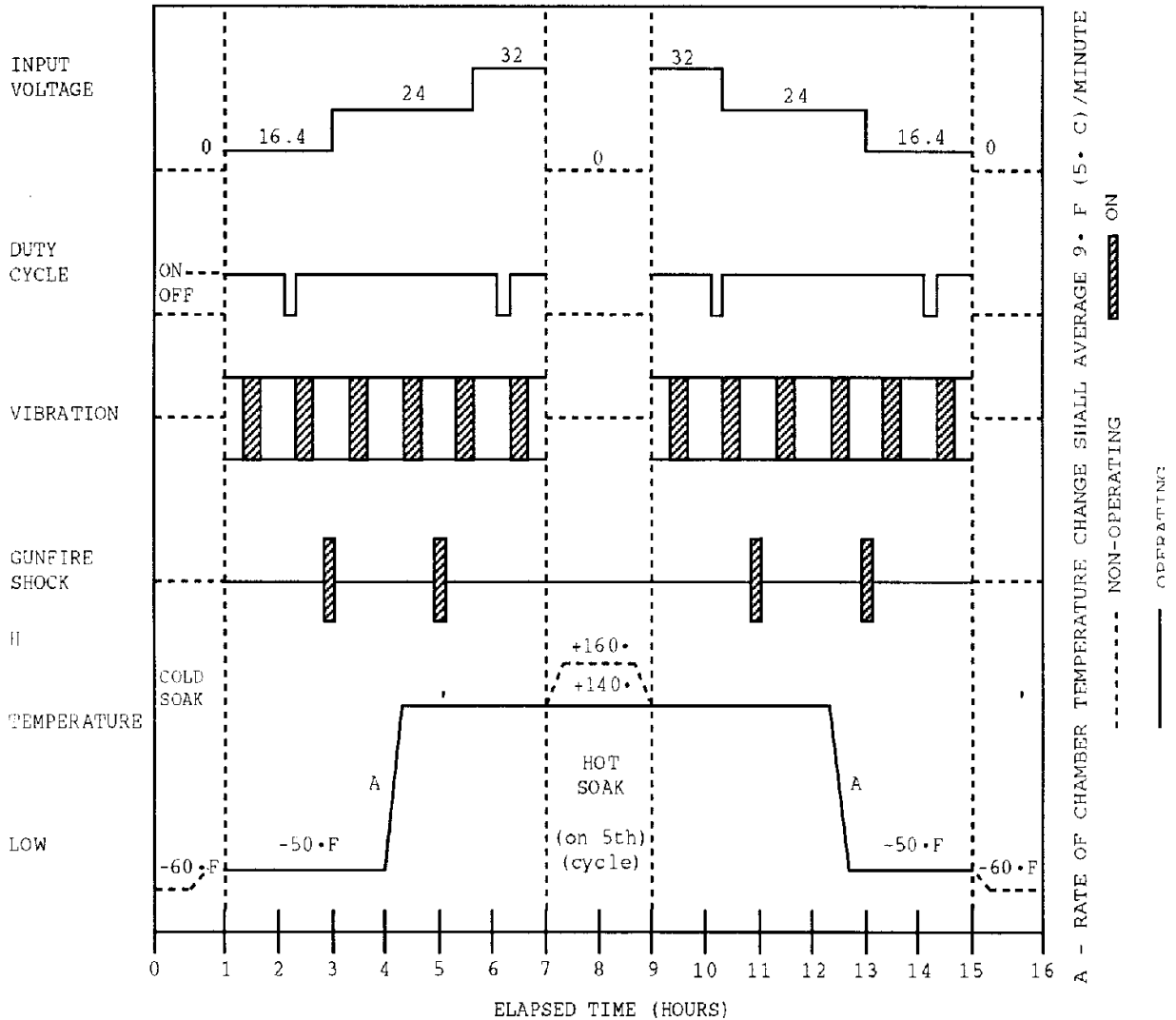

Figure 4. Chamber test cycle.

4.8.6.4 Functional survey test. Functional survey test conditions and procedures shall include:

- The DRUH shall be operated in a ground vehicle over a Government approved test course.
- One functional survey test will be run in an eight-hour period.

- c. Static Align shall be performed at the starting point. Host initiated restart or realign is not permitted.
- d. The DRUH shall be operated with VMS aiding available for all functional survey tests. GPS aiding shall be available for half the functional survey tests.
- e. The vehicle shall stop no more than once every hour for a requested ZUPT.
- f. The distance traveled per survey test shall be approximately 63 miles (100 km).
- g. The test course shall have at least 11 known survey points, including starting point, approximately equally spaced. Test data shall be taken at each survey point.
- h. The test data shall meet the accuracy requirements of 3.6.2.1 - 3.6.2.3.

4.8.6.4.1 Statistical performance criteria. The following sets of data shall meet the statistical criteria established for survey parameters (3.6.2):

- a. All accumulated data, excluding initialization point position data.
- b. At least 98 percent of the individual missions containing 10 or more survey control points. All data obtained in an individual mission shall be used to compute that mission's statistics. (Initialization point position data excluded.)
- c. All the individual survey control points at which 20 or more measurements were made using essentially the same mission trajectory. Only errors exceeding the maximum (99 percent) individual error limits may be excluded from these calculations. (Initialization point azimuth data shall be included.)

Statistical computations shall be as defined in 6.3.4.

4.8.6.5 Failure definition. The term failure is defined as any malfunction which causes or may cause the system to be inoperable or to:

- a. Fail to commence operation, cessation of operation or degradation of performance below designated levels.
- b. Damage to the system if operation is continued.

- c. Results in personnel or equipment safety hazards.

A pattern failure is defined as two or more occurrences of the same failure.

Malfunctions that require corrective action will be charged as a failure against the DRUH. The following are counted as equipment failures:

- a. A malfunction detected or corrected during the correction of another failure, provided the failures are totally unrelated.
- b. Actual or incipient malfunctions detected during technical inspection at termination of test.
- c. Failure to meet any accuracy requirement.
- d. Spurious BIT failure indications.

The following malfunctions are not considered to be equipment failures:

- a. Malfunctions caused by improper operational procedures.
- b. Malfunctions caused by abuse, unspecified operating conditions, or accidents.
- c. Malfunctions resulting from failure of the vehicle or other associated equipment unless it is determined that the DRUH contributed to the malfunction.

4.8.6.6 Action taken in event of an equipment failure.

Testing shall be stopped when a failure occurs, or whenever it becomes evident that the DRUH will not meet a specified requirement or will not pass a test. Occurrence of a pattern failure or design or software induced failure shall be a reject condition.

4.8.7 Maintainability demonstration. Maintenance operations required during the Reliability Demonstration specified in 4.8.6 shall be accomplished to determine conformance to 3.5.2. In the event that the maintenance operations performed are insufficient to quantitatively assess the corrective maintenance specified in 3.5.2, the Government may perform or simulate additional maintenance tasks as required to complete the assessment. Failure to maintain the DRUH as specified in 3.5.2 shall constitute failure of this test.

4.8.8 Performance demonstration. The Government may test the DRUH for compliance to any of the criteria specified in 3.6, including accuracy at high latitudes and for all align type and aiding combinations, and tolerance to gun firing shock. Actual or simulated installation conditions, environments, and operational scenarios may be used. Failure of the DRUH to perform as specified shall constitute failure of the test.

4.8.9 Design validation. The requirements specified in 3 shall be verified as identified in Table XXII. Characteristics to be verified shall include, but not be limited to, the following:

- a. Static align accuracy (3.6.2.3) and time (3.6.2, 3.6.3.1) shall be demonstrated at the latitude of the test facility, over the specified operating temperatures (3.4.1.1), with the DRUH oriented at each of the cardinal headings. The DRUH shall be turned off for 1 hour between alignments for tests performed at -50°F. Static align accuracy (3.6.2.3) and time (3.6.2, 3.6.3.1) shall be verified by analysis or demonstration at high latitudes in both hemispheres.
- b. Dynamic align accuracy (3.6.2.3) and time (3.6.3.3) shall be tested over the allowable ranges of GPS availability and host dynamics (3.6.5.3).
- c. Aiding selection characteristics (3.3.7.1) shall be demonstrated for all combinations of allowable aids (3.3.7).
- d. ZUPT characteristics, acceptance and duration (3.3.7.4, 3.3.7.4.1) shall be demonstrated over the allowable range of base motion (3.6.5.2).
- e. Insensitivity to odometer calibration and alignment of DRUH case to direction of travel (3.6.6.1 i.) shall be demonstrated over the range of vehicle and terrain conditions.
- f. Operation and power consumption over the input power voltage range, with ripple, surges and spikes, (3.3.13.3) shall be demonstrated.
- g. Protection from loss of power, surges, spikes, over-voltages, starting disturbances, polarity reversal, and over-current (3.3.13.3, 3.3.13.3.2) shall be verified by demonstration or analysis.
- h. Power control characteristics (3.3.13.3.1) shall be demonstrated.

- i. Regulated output power voltage, current, ripple and capacitor charging characteristics (3.3.13.3.3) shall be demonstrated.
- j. Unregulated output power voltage, current and switching characteristics (3.3.13.3.4) shall be demonstrated.
- k. RS-422 (3.3.13.4.1) and MIL-STD-1553 (3.3.13.7) signal circuit characteristics shall be verified by analysis or demonstration.
- l. Host RS-422 (3.3.13.4.3) and MIL-STD-1553 Data Bus (3.3.13.7), command acceptance and response message format, timing and data element characteristics shall be verified by analysis or demonstration.
- m. GPS receiver control, status reporting, warning message, and RS-422 data command and message format, timing and data element characteristics (3.3.10 - 3.3.10.5, 3.3.13.4.4, 3.3.13.4.4.1) shall be verified by analysis or demonstration.
- n. Travel Lock Discrete operation (3.3.13.4.5) shall be demonstrated.
- o. VMS interface control, data acceptance and BIT characteristics (3.3.13.4.6) shall be verified by analysis or demonstration.
- p. Travel lock determination, shot detect and related STATUS DATA and ALERT DATA indications (3.3.11 - 3.3.12) shall be demonstrated.
- q. Position update acceptance and rejection characteristics (3.3.7.5 - 3.3.7.5.9) shall be demonstrated over the range of acceptable and unacceptable input data.
- r. Configuration tailoring for fixed and host programmable configurations (3.3.1) shall be demonstrated over the allowable ranges of configuration codes and data elements.
- s. Angular rate accuracy (3.6.2.5) shall be verified by demonstration or analysis, over the allowable ranges of angular rates, in each axis.
- t. Insensitivity to off-level alignment conditions (3.6.5.1) shall be verified by demonstration or analysis over the range of allowable orientations.

- u. Operation when pitched 90 degrees (3.6.6.2 b.) shall be demonstrated.
- v. Interchangeability of DRUHs in host systems without hardware changes, calibration procedures, driving constraints and unscheduled ZUPTs (3.5.9) shall be demonstrated. Interchangeability of parts, subassemblies and assemblies shall be verified by analysis.
- w. Data entry checking and accept/reject responses(3.3.4.5) shall be demonstrated.
- x. Built-In-Test accuracy, characteristics, indications and reporting (3.3.9 - 3.3.9.4.3.3) shall be verified by demonstration or analysis.
- y. Personnel safety (3.5.10) shall be verified by examination or analysis for installation, operation, maintenance and repair.
- z. Useful life (3.5.12) shall be verified by analysis of component expected lifetimes and degradation resulting from operational and storage conditions.
- aa. Transport accuracy (3.6.2.4) shall be verified by demonstration or analysis for marine and air transport conditions, with and without GPS aiding.

Failure to meet any specified requirement shall constitute failure of the test.

#### 4.8.10 Nuclear survivability validation.

4.8.10.1 Tests and analyses. Tests and analyses shall be performed on the equipment in its intended operating configuration to assure the system nuclear survivability as specified in 3.4.18.

Simulation tests that do not reproduce all the required parameters of any stated environment must be extended through analysis to indicate the significance of that test and its relation to the threat environment.

4.8.10.2 Electromagnetic pulse (EMP). The equipment in its intended deployment configuration(s) and operational modes, which are worst case for the nuclear EMP environments, shall be exposed at the threat levels specified in "Nuclear Survivability Criteria for the Modular Azimuth Position System (MAPS), equipment survivability category: man in truck or signal shelter, equipment exposed".

4.8.10.3 Initial nuclear radiation. Ground-based systems and equipment shall be tested within the irradiation volume of an appropriate radiated-wave, ground-effect EMP simulator. Placement of the system equipment within the simulator test volume shall ensure worst-case EMP coupling. Current injection tests are necessary to verify the functionality of and hardness margin afforded by the protection devices employed at the equipment signal and power interfaces.

The equipment shall be exposed at threat level in the above orientations and in each operating mode of the equipment. The equipment shall meet the operational requirements of Section 3, upon completion of threat level tests. Where approved by the Government, test data to satisfy the EMP requirements may be obtained by extrapolation of diagnostic test levels to threat level and current injection pulsing at the calculated level.

4.8.10.4 Initial nuclear radiation. For the purpose of design, but not validation testing, optical components, electronic piece-parts, and circuits for which nuclear test data are available, or for which an acceptable level of confidence has been established through mathematical analysis need not be subjected to further nuclear design testing. Acceptance of these optical components, electronic piece-parts, circuits and mathematical analysis will be determined by the procuring agency from data or analyses supplied to the Government by the contractor. Nuclear survivability at the specified temperature extremes will be demonstrated by appropriate analysis and tests or, where acceptable, by analysis alone. The assembled equipment shall be tested for hardness to exposure to neutron fluence, total dose, and peak gamma dose rate.

4.8.10.4.1 Neutron fluence. The equipment shall be exposed in such a manner that all optical components, electronic piece-parts and circuits receive the Neutron Fluence specified in paragraph 3.4.18. The equipment shall be energized, if appropriate to examine worst case response. The equipment shall perform as specified in 3.

4.8.10.4.2 Total dose. The equipment shall be exposed in such a manner that all optical components, electronic piece-parts, and circuits receive the Total Dose specified in paragraph 3.4.18. The equipment shall be energized during exposure and shall then perform as specified in 3. Except for fiber optics and n-channel metal-oxide semiconductors (NMOS), verification of device hardness against permanent damage from gamma ray dose may be achieved by the gamma output that normally accompanies the Neutron Fluence. Gamma dose hardness of fiber optics and NMOS devices must be verified by Cobalt-60 irradiation

in which the Total Dose specified is delivered in a steady-state exposure on the order of 20 seconds duration.

4.8.10.4.3 Peak gamma dose rate. The equipment shall be exposed in such a manner that all optical components, electronic piece-parts, and circuits receive the Peak Gamma Dose specified. The equipment shall be energized during exposure and shall then perform as specified in 3.

4.8.10.5 Thermal radiation. The equipment in its intended deployment configuration(s), which are worst case(s) for the nuclear thermal and air-blast environments, shall be subjected to thermal radiation tests at appropriate thermal radiation levels over the entire exposed surface(s) of the equipment. In instances where only thermal radiation facilities that can be used provide these specified levels over only relatively small areas of the equipment's surfaces, individual exposures will be required for each of the candidate surface and outboard items to ensure the thermal radiation survivability of the equipment. In such instances, thermal radiation tests of selected material samples (of the surfaces and items) may be appropriate. Following the thermal radiation tests, the equipment shall then meet the performance requirements stipulated in 3.

4.8.10.6 Nuclear air blast. The equipment in its intended deployment configuration(s) which are worst case(s) for nuclear thermal and air-blast environments, shall be subjected to air-blast tests at the appropriate air-blast simulation facilities that provide the specified air-blast levels. The equipment air-blast sensitivity(ies) as determined through appropriate analyses, drive the selection of the simulation environments to be used. The selected air-blast simulator(s) must be capable of providing the specified air-blast threat environment characteristic(s) needed to demonstrate equipment compliance in meeting air-blast requirements. For equipment that is housed within an enclosure, the equipment must survive the induced shocks and accelerations that are transmitted through the enclosure when the enclosure is subjected to the specified nuclear air-blast environments. In both instances, for equipment exposed directly to the air-blast environment and for equipment protected within an enclosure, the equipment shall meet the operational requirements of 3 following the air-blast test.

Tests or analysis shall be performed to account for synergistic effects of thermal radiation received before the Nuclear Air-Blast.

4.8.11 Y2K Compliance. Demonstration or analysis shall verify proper rollover from the twentieth to twenty-first centuries. Output of incorrect date/time or failure of the DRUH

to operate in accordance with 3.6 shall constitute failure of this verification.

## 5. PACKAGING

5.1 Packaging requirements. For acquisition purposes, the packaging requirements shall be as specified in the contract or order (see 6.2). When actual packaging of materiel is to be performed by DoD personnel, those personnel need to contact the responsible packaging activity to ascertain requisite packaging requirements. Packaging requirements are maintained by the Inventory Control Point's packaging activity within the Military Department or Defense Agency, or within the Military Department's System Command. Packaging data retrieval is available from the managing Military Department's or Defense Agency's automated packaging files, CD-ROM products, or by contacting the responsible packaging activity.

## 6. NOTES

(This section contains information of a general or explanatory nature which may be helpful, but is not mandatory.)

6.1 Intended use. The DRUH is a positioning and orienting sub-system for use on weapon and target systems. Electronic odometer (VMS) signals and GPS position and time data may optionally aid it. The DRUH may be used in a variety of host system configurations. Figure 5 shows the DRUH integrated with a host computer, VMS and GPS receiver. Figure 6 shows a configuration using a Control and Display Unit (CDU) operator interface and no VMS or GPS aiding.

The DRUH covered by this specification is military unique. It is mounted to the gun trunnion of the M109A6 Self-Propelled Howitzer and must operate through the extreme levels of gunfire shock. It also must operate after exposure to the nuclear, biological and chemical warfare environments and subsequent decontamination. Commercial inertial navigation systems are not designed to withstand such extreme environmental conditions and would experience catastrophic failure. The DRUH is used by multiple host systems and has extensive electronic data interchange requirements. There is no commercial specification or standard covering the command and message formats.

6.2 Acquisition requirements. Acquisition documents must specify the following:

- a. Title, number and date of this specification.
- b. Issue of DODISS to be cited in the solicitation, and if required, the specific issue of individual documents referenced (see 2.2.1 and 2.3).
- c. Requirements for design verification.
- d. Requirements for submission of first article samples.
- e. Applicable National Stock Number (NSN).
- f. Packaging requirements, (see 5.1).
- g. Serialization requirements, if applicable.
- h. Certificate of conformance for each lot or shipment of product.

- j. Alternate software package functionality requirements (see 3.3.2).
- k. Year 2000 (Y2K) compliance certification requirements (see 3.3.15).

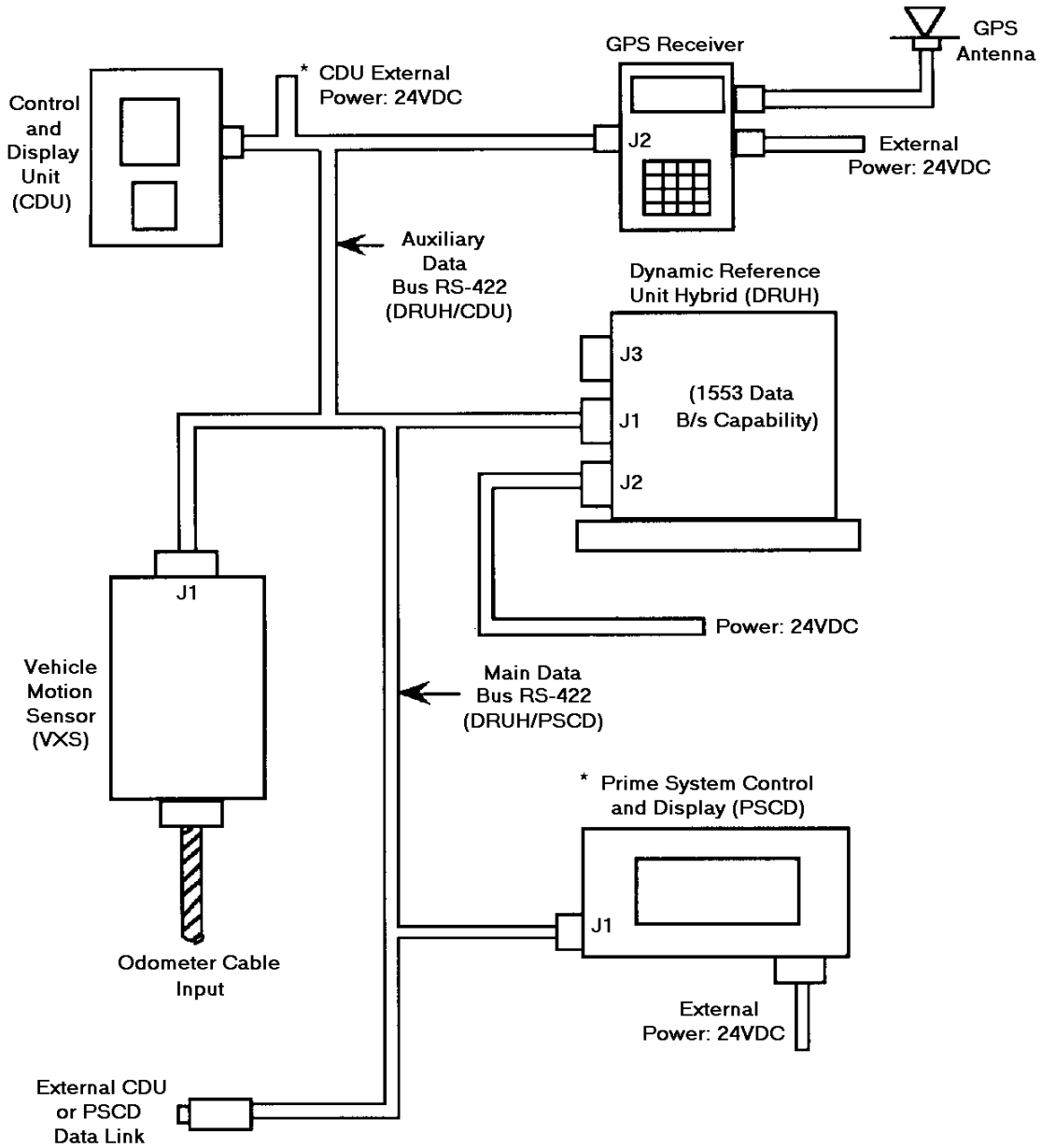

\* CDU Power may be provided via DRUH J1 connector.

Figure 5. Integrated system with VMS and GPS aiding.

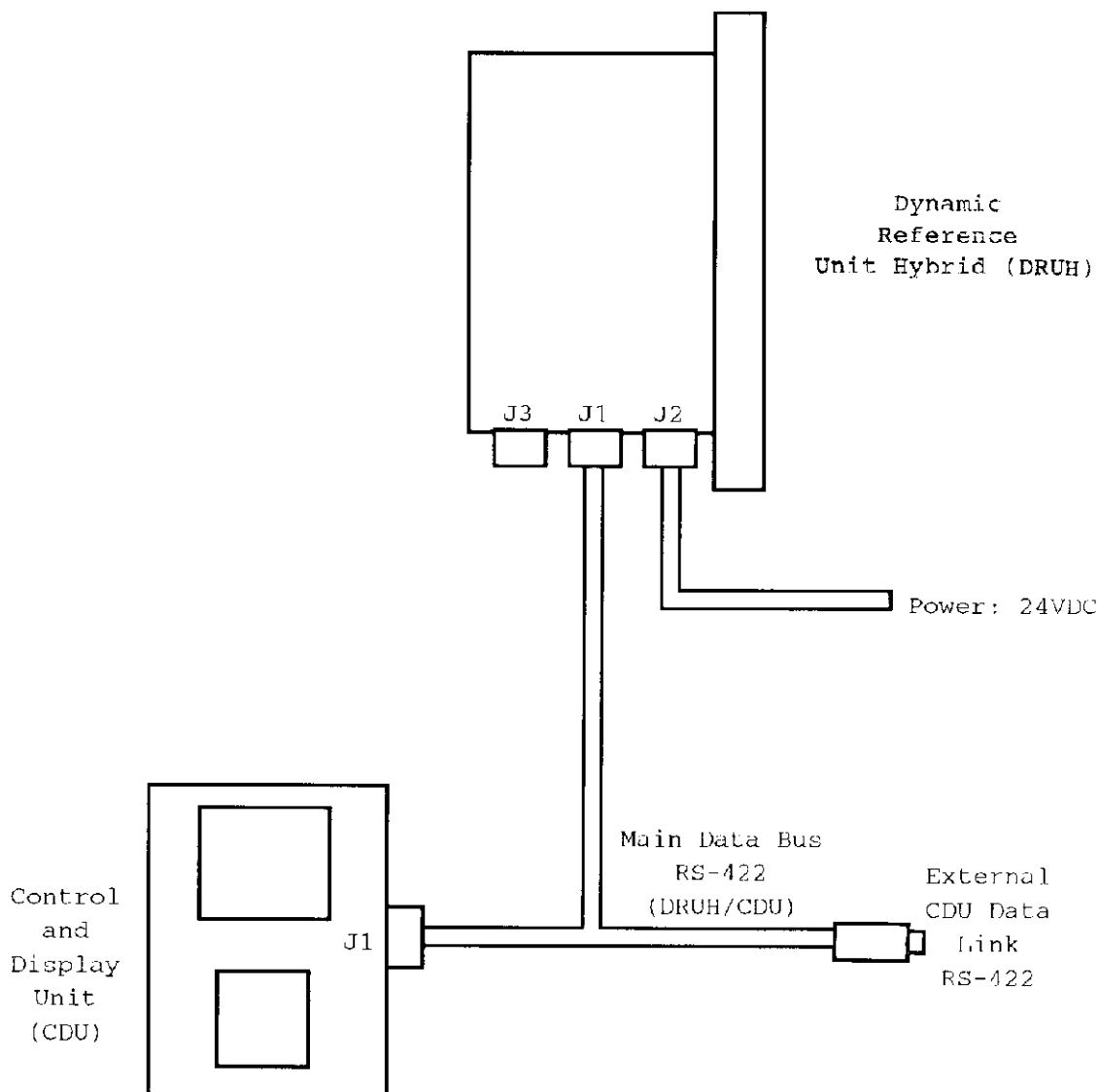

Figure 6. Stand alone system with no VMS or GPS aiding.

### 6.3 Definitions.

6.3.1 Orientation reference frames. DRUH orientation is defined by the relationship of the DRUH case coordinate frame to an earth referenced coordinate frame. An intermediate DRUH coordinate frame relates the case coordinate frame to the DRUH mounting orientation. Suitable DRUH coordinate frame codes and boresight angles should be selected for each installation to

insure proper definition of orientation parameters during pointing device deployment (DRUH rotation).

6.3.1.1 DRUH case coordinate frame. The DRUH case reference frame (Figure 7) is a set of right hand orthogonal axes,  $\bar{X}_C$ ,  $\bar{Y}_C$ ,  $\bar{Z}_C$ . The origin and axes are related to the case mechanical datums, shown in Appendix F, as follows. The origin is located where the center axis of alignment hole R (DATUM axis V) intersects the precision mounting surface, DATUM plane G-U. The longitudinal axis,  $\bar{X}_C$ , is along the intersection of DATUM plane G-U and Section A-A, which passes through the centers of alignment holes R and D. The transverse axis,  $\bar{Y}_C$ , coincides with DATUM axis V. The vertical axis,  $\bar{Z}_C$ , is along the intersection of DATUM plane G-U and DATUM plane Z, which passes through the center of the mounting holes.

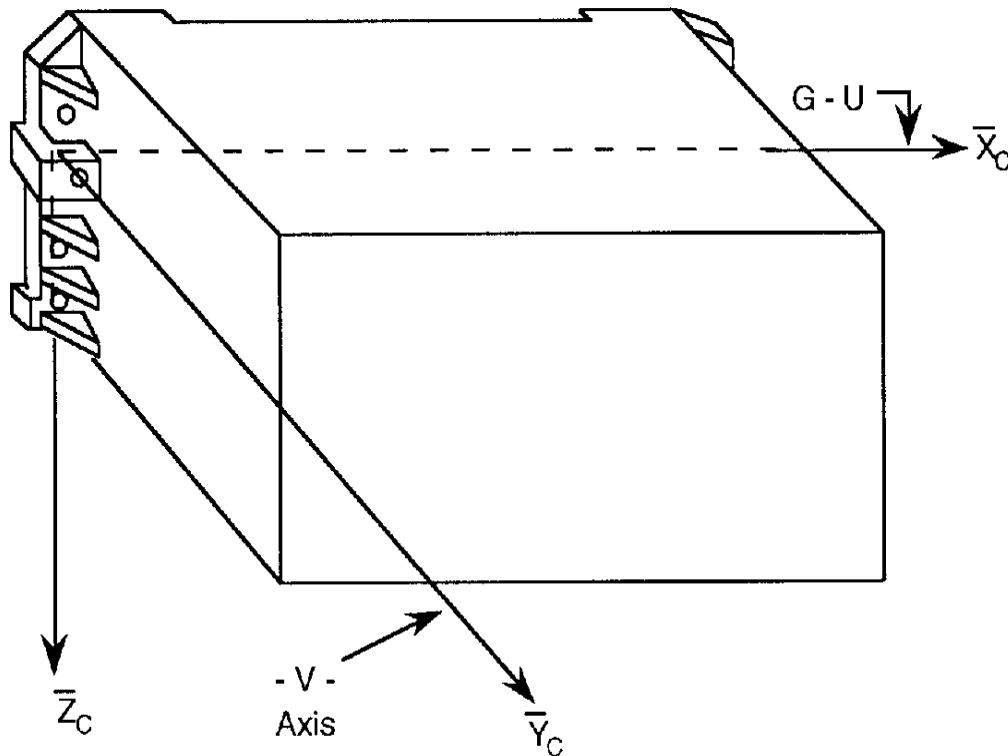

Figure 7. DRUH case coordinate frame.

6.3.1.2 DRUH coordinate frame. The DRUH coordinate frame is an intermediate set of right hand orthogonal axes,  $\bar{X}_D$ ,  $\bar{Y}_D$ ,  $\bar{Z}_D$ , as shown in Figure 8a. The case coordinate frame is related to the DRUH coordinate frame by a unit rotation matrix [R]. Elements of

the rotation matrix,  $R_{ij}$ , may have the values -1, 0, 1. Examples are shown in Figure 8b and Figure 8c. The relationship between the case and DRUH coordinate frames is specified by coordinate frame codes (see Appendix C.) There are separate coordinate frame codes for Orientations 1 and 2.

6.3.1.3 Pointing device reference frame. The Pointing Device reference frame is a body referenced set of right hand orthogonal axes,  $\bar{X}_P$ ,  $\bar{Y}_P$ ,  $\bar{Z}_P$ . The axes are related to the Pointing Device as follows. The longitudinal axis,  $\bar{X}_P$ , is along the direction of pointing and is positive in the direction of pointing. The transverse axis,  $\bar{Y}_P$ , coincides with the Pointing Device cross axis. The vertical axis,  $\bar{Z}_P$ , is orthogonal to  $\bar{X}_P$  and  $\bar{Y}_P$  and is positive downward when  $\bar{X}_P$  and  $\bar{Y}_P$  are level. The Pointing Device reference frame and DRUH coordinate frame are related by the Pointing Device Boresight Angles (see Appendix C.)

6.3.1.4 Vehicle reference frame. The Vehicle reference frame is a body referenced set of right hand orthogonal axes,  $\bar{X}_V$ ,  $\bar{Y}_V$ ,  $\bar{Z}_V$ . The axes are related to the vehicle chassis as follows. The longitudinal axis,  $\bar{X}_V$ , is along the direction of forward motion and is positive forward. The transverse axis,  $\bar{Y}_V$ , coincides with the Vehicle cross axis. The vertical axis,  $\bar{Z}_V$ , is orthogonal to  $\bar{X}_V$  and  $\bar{Y}_V$  and is positive downward when  $\bar{X}_V$  and  $\bar{Y}_V$  are level. The Vehicle reference frame and DRUH coordinate frame are related by the Vehicle Boresight Angles (see Appendix C.)

6.3.1.5 Earth reference coordinate frame. The earth reference coordinate frame is an orthogonal coordinate set  $\bar{X}_E$ ,  $\bar{Y}_E$ ,  $\bar{Z}_E$ .  $\bar{X}_E$  points north,  $\bar{Y}_E$  east, and  $\bar{Z}_E$  downward along the local vertical.

6.3.2 Orientation parameters. The DRUH orientation parameters are defined in terms of rotations between the earth reference, intermediate, and DRUH coordinate frames, as shown in Figure 9, and boresight angles (see Appendix C) relating the vehicle and pointing device reference frames to the DRUH coordinate frame.

6.3.2.1 Pointing device cant. Pointing Device Cant is the vertical angle between the pointing device transverse axis, immediately clockwise from the direction of pointing, and the projection of that transverse axis onto the horizontal plane. Pointing Device Cant is positive when the transverse axis lies below the horizontal plane and negative when above.

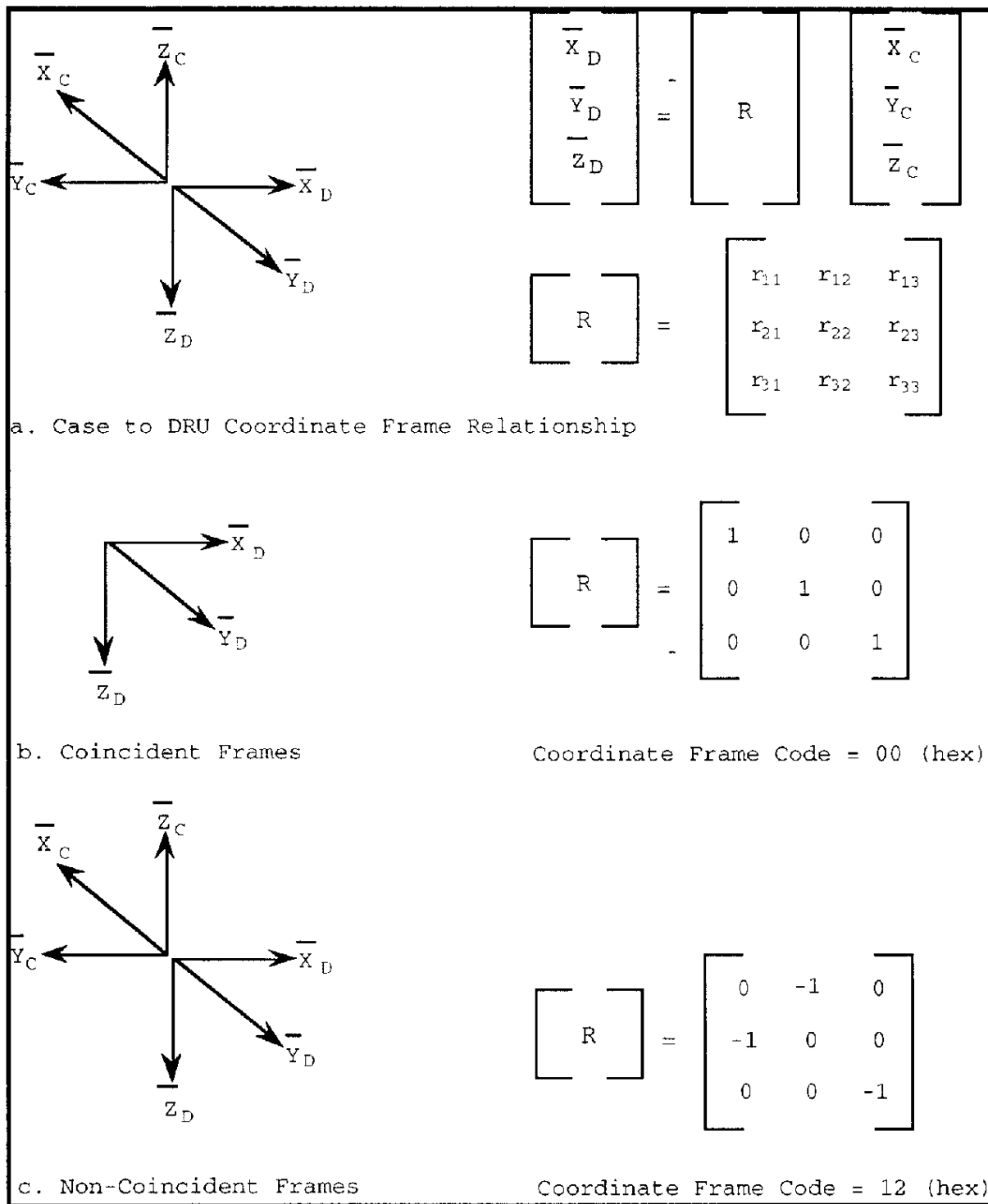
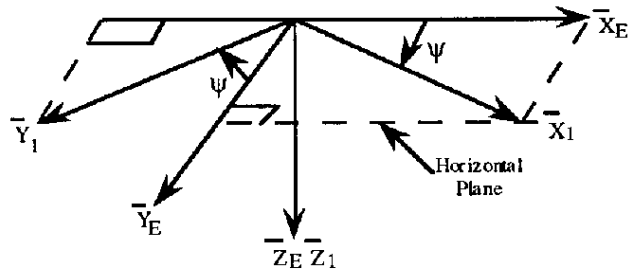

Figure 8. DRUH coordinate frame.

$$\begin{bmatrix} \bar{X}_D \\ \bar{Y}_D \\ \bar{Z}_D \end{bmatrix} = \Phi * \Theta * \Psi \begin{bmatrix} \bar{X}_E \\ \bar{Y}_E \\ \bar{Z}_E \end{bmatrix}$$

$$\Psi = \begin{bmatrix} \cos \Psi & \sin \Psi & 0 \\ -\sin \Psi & \cos \Psi & 0 \\ 0 & 0 & 1 \end{bmatrix}$$



$$\Theta = \begin{bmatrix} \cos \Theta & 0 & -\sin \Theta \\ 0 & 1 & 0 \\ \sin \Theta & 0 & \cos \Theta \end{bmatrix}$$

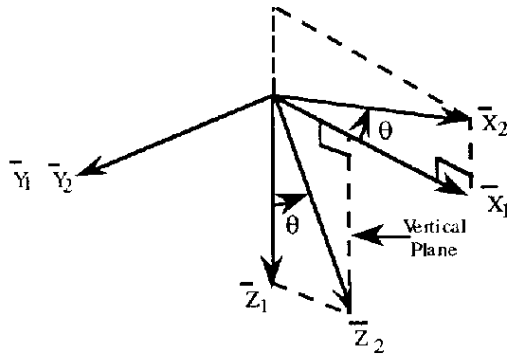

$$\Phi = \begin{bmatrix} 1 & 0 & 0 \\ 0 & \cos \Phi & \sin \Phi \\ 0 & -\sin \Phi & \cos \Phi \end{bmatrix}$$

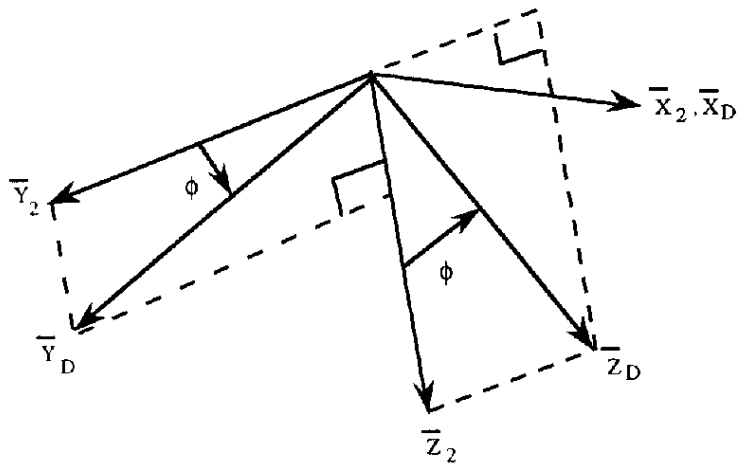

where:

$\Psi$  = Azimuth

$\Theta$  = Pitch

$\Phi$  = Roll

Figure 9. Orientation parameters.

6.3.2.2 Pointing device geodetic azimuth. Pointing Device Geodetic Azimuth is the horizontal angle between geodetic (true)

north and the vertical projection of the pointing device longitudinal axis, in the direction of pointing, onto the horizontal plane. Pointing Device Geodetic Azimuth is measured clockwise from geodetic north and is always positive.

6.3.2.3 Pointing device grid azimuth. Pointing Device Grid Azimuth is the horizontal angle between grid north (see Appendix G) and the vertical projection of the pointing device longitudinal axis, in the direction of pointing, onto the horizontal plane. Pointing Device Grid Azimuth is measured clockwise from grid north and is always positive.

6.3.2.4 Pointing device pitch. Pointing Device Pitch is the vertical angle between the projection of the pointing device longitudinal axis onto the horizontal plane and the axis. Pointing Device Pitch is positive when the axis, in the direction of pointing, lies above the horizontal plane and negative when below.

6.3.2.5 Pointing device roll. Pointing Device Roll is the angle between the horizontal plane and the pointing device transverse axis immediately clockwise from the direction of pointing measured in a plane normal to the pointing device longitudinal axis. Pointing Device Roll is positive when the transverse axis lies below the horizontal plane and negative when above.

6.3.2.6 Travel lock pointing device geodetic or grid azimuth reference. When the DRUH is in travel lock, Travel Lock Geodetic or Grid Azimuth Reference equals the present Pointing Device Geodetic or Grid Azimuth. When the DRUH is out of travel lock, Travel Lock Geodetic or Grid Azimuth Reference equals the value of Pointing Device Geodetic or Grid Azimuth when last in travel lock.

6.3.2.7 Travel lock pointing device pitch reference. When the DRUH is in travel lock, Travel Lock Pitch Reference equals the present Pointing Device Pitch. When the DRUH is out of travel lock, Travel Lock Pitch Reference equals the value of Pointing Device Pitch when the pointing device was last in travel lock.

6.3.2.8 Vehicle cant. When the DRUH is in travel lock, Vehicle Cant is the vertical angle between the vehicle cross axis immediately clockwise from the direction of travel and the projection of that cross axis onto the horizontal plane. Vehicle Cant is positive when the cross axis lies below the horizontal plane and negative when above. When the DRUH is out of travel lock, Vehicle Cant equals the value of Vehicle Cant when last in travel lock.

6.3.2.9 Vehicle geodetic or grid azimuth. When the DRUH is in travel lock, Vehicle Geodetic or Grid Azimuth is the geodetic or grid azimuth of the vehicle longitudinal axis in the direction of travel and is the horizontal angle between geodetic or grid north (see Appendix G) and the vertical projection of the longitudinal axis onto the horizontal plane. Vehicle Geodetic or Grid Azimuth is measured clockwise from geodetic or grid north and is always positive. When the DRUH is out of travel lock, Vehicle Geodetic or Grid Azimuth equals the value of Vehicle Geodetic or Grid Azimuth when last in travel lock.

6.3.2.10 Vehicle pitch. When the DRUH is in travel lock, Vehicle Pitch is the vertical angle between the projection of the longitudinal axis of the vehicle onto the horizontal plane and the axis. Vehicle Pitch is positive when the axis in the direction of travel lies above the horizontal plane and negative when below. When the DRUH is out of travel lock, Vehicle Pitch equals the value of Vehicle Pitch when last in travel lock.

6.3.2.11 Vehicle roll. When the DRUH is in travel lock, Vehicle Roll is the angle between the horizontal plane and the vehicle cross axis, immediately clockwise from the direction of travel, measured in a plane normal to the vehicle longitudinal axis. Vehicle Roll is positive when the cross axis lies below the horizontal plane and negative when above. When the DRUH is out of travel lock, Vehicle Roll equals the value of Vehicle Roll when last in travel lock.

6.3.3 Angular rate parameters. Pointing Device angular rate parameters are defined in terms of angular velocities around the Pointing Device reference frame axes. Pointing Device angular rates are body referenced, not earth referenced.

6.3.3.1 Pointing device azimuth rate. Pointing Device Azimuth Rate is the angular rate about the pointing device vertical axis,  $\bar{Z}_p$ . Pointing Device Azimuth Rate is positive when the pointing device reference frame is rotated about  $\bar{Z}_p$  in a positive direction, as defined by the right hand rule.

6.3.3.2 Pointing device pitch rate. Pointing Device Pitch Rate is the angular rate about the pointing device transverse axis,  $\bar{Y}_p$ . Pointing Device Pitch Rate is positive when the pointing device reference frame is rotated about  $\bar{Y}_p$  in a positive direction, as defined by the right hand rule.

6.3.3.3 Pointing device roll rate. Pointing Device Roll Rate is the angular rate about the pointing device longitudinal axis,  $\bar{X}_p$ . Pointing Device Roll Rate is positive when the

pointing device reference frame is rotated about  $\bar{X}_p$  in a positive direction, as defined by the right hand rule.

#### 6.3.4 Error Parameters.

6.3.4.1 Circular error probable (CEP). CEP is the radius of a circle, centered about true, such that any measured position, selected from the total sample population, has a 50 percent probability of lying inside the circle.

$$\text{CEP} = 1.1774 \times \frac{\text{RMS}_N + \text{RMS}_E}{2}$$

Where:  $\text{RMS}_N$  and  $\text{RMS}_E$  are the RMS errors in Northing and Easting, respectively

6.3.4.2 Radial error. Radial error is the linear difference in horizontal position between the measured reference values for a single position measurement.

$$\text{Radial Error} = [(\text{m}_E - \text{M}_E)^2 + (\text{m}_N - \text{M}_N)^2]^{1/2}$$

Where:  $\text{m}_E$  and  $\text{m}_N$  are the measured Easting and Northing, respectively

$\text{M}_E$  and  $\text{M}_N$  are the reference Easting and Northing, respectively

6.3.4.3 RMS error. RMS error is the square root of the mean of the sum of the squared errors, relative to the reference value(s), for all measurements in the sample population.

$$\text{RMS}_x = \sqrt{\frac{\sum_{i=1}^N (x_i)^2}{N}}$$

Where:

$N$  is the total number of measurements in the sample.

$x_i$  is the error in the  $i$ 'th measurement with respect to the reference value.

$x_i = m_i - M_i$  for linear or angular errors.

$x_i = 100 \times \frac{m_i - M_i}{S_i - S_0}$  for percent of distance traveled errors.

$$X_i = \frac{(m_i - M_i) - (m_0 - M_0)}{T_i - T_0} \quad \text{for drift errors.}$$

$m_i$  is the  $i$ 'th measurement in the sample. ( $m_0$  is the initial measurement)

$M_i$  is the reference value associated with the  $i$ 'th measurement.

$S_i - S_0$  is the odometer distance traveled since the last position update.

$T_i - T_0$  is the travel time since the last alignment.

6.3.4.4 Probable error (PE). PE is the equally likely deviation (50 percent probability) of a set of linear measurements about the true (reference) value.

$$PE = 0.6745 \times RMS_x$$

6.3.4.5 Standard deviation about the mean. The Standard Deviation about the Mean ( $\sigma$ ) is the measurement of the dispersion of the measurements in a sample about the arithmetic mean.

$$s = \sqrt{\frac{\sum_{i=1}^N (m_i - \bar{m})^2}{N-1}}$$

Where:

$N$  is the total number of measurements in the sample.

$m_i$  is the  $i$ 'th measurement in the sample.

$\bar{m}$  is the arithmetic mean of the sample.

$$\bar{m} = \frac{\sum_{i=1}^N m_i}{N}$$

6.3.5 Travel lock. If the host has a pointing device, such as a gun tube, radar antenna, or sensor pod, the DRUH is normally mounted to the pointing device. When the pointing device is stowed for travel by physically clamping it to the vehicle chassis, it is said to be "in travel lock". When the pointing device is unclamped and elevated/rotated, it is said to be "out of travel lock".

6.3.6 Year 2000 compliant. Information technology accurately processes date/time data (including, but not limited to, calculating, comparing, and sequencing) from, into, and between the twentieth and twenty-first centuries, and the years 1999 and 2000 and leap year calculations to the extent that other information technology, used in combination with the information technology being acquired, properly exchanges date/time data with it.

#### 6.4 Additional information.

6.4.1 Text conventions. The following conventions are used in the main text and appendices of this document:

- a. For discrete (binary) data elements, set = 1 (binary) and reset = 0 (binary).
- b. Command and message names are capitalized.
- c. Configuration definition flags are identified by their data byte/bit locations in the RS-422 ACCEPT CONFIGURATION DATA command (for example, CFG D26/7). (Appendix C.)
- d. Status indications are identified by their status byte/bit location in the RS-422 STATUS DATA message (for example, STATUS DATA S2/6). (Appendix B.)
- e. Alert indications are identified by their data byte/bit location in the RS-422 ALERT DATA message (for example, ALERT DATA D4/7). (Appendix B.)
- f. Failure indications (3.3.4.3) are identified by their data byte/bit location in the RS-422 BUILT-IN-TEST (BIT) DATA message (for example, BIT DATA D1/7). (Appendix B.)
- g. Expressions containing multiple uses of "and" or "or" are logical expressions. Punctuation, "()", "[ ]", and "{ }" indicate evaluation order in logical expressions.

6.4.2 Gun firing shock data. Gun firing shock data are available in the two TECOM Reports No. 86-LR(V)-41, Firing Test of M109E4 Howitzer, dated 24 September 1986 and 10 March 1987. The DRUH is trunnion mounted in the M109A6 application.

6.4.3 Vibration data. Vibration data for the M109 and M113 are contained in TECOM Reports, No. 87-LR(V)-2, Road Shock and Vibration Test of M109E4 Howitzer, 28 January 1987, and No. 87-LR(R)-1, Road Shock and Vibration Test of MAPS Hardware in M113A1, 14 January 1987, respectively.

6.5 Acronyms and abbreviations. The following acronyms and abbreviations may be used in the main text or appendices of this specification.

1PPS	One pulse per second
2b	Two's complement binary
ACK	Acknowledge
Alt	Altitude
ASCII	American Standard Code for Information Exchange
b	Binary
BIT	Built-In-Test
BNG	British National Grid
BTU	British Thermal Unit
C	Centigrade
CEP	Circular Error Probable
CFIG	Configuration Data
cGy	Centi-Gray
chan	Channel
cm	Centimeter
C/N <sub>0</sub>	Carrier to Noise ration (1 Hz bandwidth)
Cos	Cosine
CRC	Cyclic Redundancy Check
CSCI	Computer Software Configuration Item
CUCV	Commercial Utility Cargo Vehicle
dB	Decibels
DC	Direct Current
deg	Degrees
dis	Discrete
DIST	Distance
DODISS	Department of Defense Index of Specification and Standards
DRUH	Dynamic Reference Unit Hybrid
E	East
EIA	Electronic Industries Association
EHE	Estimated Horizontal Error
EMC	Electromagnetic Compatibility
EMI	Electromagnetic Interference
EMP	Electromagnetic Pulse
EPE	Estimated Position Error
ESS	Environmental Stress Screening
EVE	Estimated Vertical Error

F	Fahrenheit
FOM	Figure of Merit
fps	Feet per second
FREQ	Frequency
ft	Feet
g	Gram
G	Gravity
GBq	Giga-Becquerel
GHz	Giga-Hertz
GPS	Global Positioning System
hex	Hexadecimal
hi	High
hr	Hour
Hz	Hertz
ID	Identifier
in	Inch
K	One thousand
kg	Kilogram
kHz	Kilohertz
km	Kilometer
Lat	Latitude
lbs	Pounds
Lo	Low
Lon	Longitude
LRU	Line Replaceable Unit
LSB	Least Significant Bit
m	Meter
M	Mil
m/sec	Meters per Second
ma	Milliampere
max	Maximum
MGRS	Military Grid Reference System
MHz	Megahertz
min	Minutes
mm	Millimeter
MMD	Mass Median Diameter
mps	Meters per second
MSB	Most Significant Bit
msec	Millisecond
MSH	Most Significant Half
MSL	Mean-Sea-Level
MTBF	Mean-Time-Between-Failure
MTTR	Mean-Time-To-Repair
mv	Millivolt

N	North
n/a	Not Applicable
NAK	Negative Acknowledge
NBC	Nuclear-Biological-Chemical
nmi	Nautical miles
NRZ	Non-Return to Zero
PD	Pointing Device
PE	Probable Error
pk-pk	Peak-to-peak
PLGR	Precision Lightweight GPS Receiver
Pos	Position
PSD	Power Spectral Density
rad	Radian
rad	Radiation unit
RCVR	Receiver
RES	Resolution
RMS	Root Mean Square
RPU	Receiver Processor Unit (GPS receiver)
RT	Remote Terminal (MIL-STD-1553)
S	South
sb	Signed Binary
SCC	Serial Communication Controller
SDLC	Synchronous Data Link Control
S/N	Serial Number
S/N	Signal to Noise ratio
SV	Space Vehicle (satellite)
S/W	Software
sec	Second
T	Time
TFOM	Time Figure Of Merit
ub	Unsigned binary
UPS	Universal Polar Stereographic
UTC	Universal Time Coordinated
UTM	Universal Transverse Mercator
V	Volts
VMS	Vehicle Motion Sensor
W	Watt
WGS	World Geodetic System
Y2K	Year 2000
ZRP	Zero Reference Point

ZUPT        Zero Velocity Update

6.10    Subject term (key word) listing.

Fire Control  
MAPS  
Navigation  
Positioning System

## APPENDIX A

## DRUH/HOST RS-422 DATA INTERFACE

## A.1. SCOPE

A.1.1 Scope. This appendix provides the requirements for a DRUH/host digital interface using RS-422 data buses. This appendix is a mandatory part of this specification. The information herein is intended for compliance.

## A.2. APPLICABLE DOCUMENTS

A.2.1 General. The documents listed in this section are specified in section 3 of this appendix. This section does not include documents in other sections of this specification or recommended for additional information or as examples. While every effort has been made to ensure the completeness of this list, document users are cautioned that they must meet all specified requirements documents cited in section 3 of this appendix, whether or not they are listed.

A.2.2 Government documents.

A.2.2.1 Other Government documents, drawings, and publications. The following other Government documents, drawings, and publications form a part of this document to the extent specified herein. Unless otherwise specified, the issues are those cited in the solicitation (see 6.2).

## OTHER GOVERNMENT DOCUMENTS

ICD-GPS-153	GPS User Equipment Interface Control Document for the RS-232/RS-422 Interface of DoD Standard GPS UE Radio Receivers
-------------	--

(Copies of ICD-GPS-153 may be obtained from the Global Positioning System (GPS) Joint Program Office (JPO), SMC/CZ, SMC/CZ, 2435 Vela Way, Suite 1613, Los Angeles Air Force Base, El Segundo, CA 90245-5500.)

A.2.3 Non-Government documents. The following documents form a part of this specification to the extent specified herein. Unless otherwise specified, the issues of the documents which are DoD adopted are those listed in the issue of the DODISS cited in the solicitation. Unless otherwise specified, the issues of documents not listed in the DODISS are the issued of documents cited in the solicitation (see 6.2).

## TECHNICAL MANUALS

Z8030/8530 SCC    Zilog Serial Communications  
Controller

(Application for copies should be addressed to Zilog Inc., 210 Hacienda Avenue, Cambell, CA 95008-6609.)

A.2.4 Order of precedence. In the event of a conflict between the text of this document and the references cited herein, the text of this document shall take precedence. Nothing in this document, however, supersedes applicable laws and regulations unless a specific exemption has been obtained.

## A.3. REQUIREMENTS

A.3.1 Host RS-422 data bus characteristics. The DRUH shall have two, independent, bi-directional, half-duplex, synchronous, serial RS-422 data buses. The two buses are labeled Main and Auxiliary. Commands and messages may be transferred between the host system and DRUH via these data buses. Either bus may be used separately or both may be used simultaneously.

The electrical characteristics (see section 3 of the main body of this specification), protocols and data formats are the same for both data buses. The only difference between the two buses is the host can inhibit DRUH acceptance of data entry and mode change commands received on the Auxiliary Bus.

Each data bus shall be in receive mode unless the DRUH is sending a message on that particular bus. The DRUH shall be able to receive a command, on the same data bus, within 1.0 milliseconds after sending the end of the last bit of a message. The DRUH shall not start sending a message until at least 1.0 milliseconds has elapsed after receipt of the end of the last bit of the command that initiated the message.

A.3.1.1 Host RS-422 data bus protocols. The Host RS-422 buses shall use the normal Synchronous Data Link Control (SDLC) protocol compatible with the Zilog Z8030 Serial Communication Controller (SCC). Data shall change after the falling edge and be valid on the rising clock edge.

A.3.1.1.1 Data encoding. Data shall be encoded in the Non-Return-to-Zero (NRZ) format compatible with the Zilog Z8030 SCC.

A.3.1.1.2 Data rate. The data rate shall be 38.4 kilobits per second. The data buses shall operate properly when provided

with 38.4 kHz,  $\pm 0.01$  percent, symmetrical squarewave clock signals compatible with the Zilog Z8030 SCC.

A.3.1.1.3 SDLC flag. Each command and message shall start and end with a single byte (8 bits) flag containing the fixed binary sequence 01111110.

A.3.1.1.4 Error detection. Each command and message shall contain a two byte (16 bit) Cyclic Redundancy Check (CRC) compatible with the SDLC protocol as implemented in the Zilog Z8030 SCC (CRC-CCITT polynomial).

Each command received by the DRUH shall be tested for correct reception. If an error is detected, the DRUH shall ignore the command, set ALERT DATA D5/0 (Undefined Command Received) and return a STATUS DATA message.

Each message sent by the DRUH shall contain the CRC computed for the information being sent.

A.3.1.2 Command and message protocols. Commands to and messages from the DRUH on either the Auxiliary or the Main Bus shall follow the protocols below:

- a. The host shall be the bus master, which initiates commands to the DRUH (slave).
- b. The DRUH shall not initiate a message without a request (command). If no communications are detected on an RS-422 bus for more than 10 seconds, the DRUH may issue no more than three SDLC flag characters, on that bus.
- c. The DRUH shall send a message in response to each command received. The message shall be returned only on the bus over which the command was received.
- d. STATUS DATA and ALERT DATA indications applicable to only one data bus, such as improper command received or error detected, shall be returned only on the applicable bus.
- e. Commands and messages shall be constructed of 8-bit bytes. Bit positions within a byte are shown below:

msb							lsb
7	6	5	4	3	2	1	0

- f. Bytes shall be transmitted in the order specified. Multi-byte data fields shall be transmitted most significant byte first. The least significant bit within a byte shall be transmitted first.

A.3.1.3 Host RS-422 data bus control. The ability to enter data into the DRUH or change operating modes via the Auxiliary Bus shall be as follows:

- a. Auxiliary Bus control shall be inhibited for 15 seconds after DRUH turn-on unless an ENABLE AUXILIARY BUS CONTROL command was accepted over the Main Bus prior to that time.
- b. At any time after 15 seconds after turn-on, Auxiliary Bus control shall automatically be enabled if no command has been received on the Main Bus within the previous two seconds.
- c. Auxiliary Bus control shall be enabled if the ENABLE AUXILIARY BUS CONTROL command is received on the Main Bus.
- d. Auxiliary Bus control shall be inhibited if the INHIBIT AUXILIARY BUS CONTROL command is received on the Main Bus.
- e. STATUS DATA S1/0 (Auxiliary Bus Control Inhibited) shall be set on all data buses when Auxiliary Bus control is inhibited and shall be reset on all data buses when Auxiliary Bus control is enabled.
- f. When Auxiliary Bus control is inhibited, the DRUH shall: accept commands indicated by "no" in the "INH" column of Table A-1, if they otherwise meet acceptance criteria; and reject the command, set ALERT DATA D5/1 (Invalid Command Received) and return a STATUS DATA message for all other commands.
- g. When Auxiliary Bus control is inhibited, receipt of an OVERRIDE ALERT command on the Auxiliary Bus shall reset only those ALERT DATA bits specific to the Auxiliary Bus.
- h. When Auxiliary Bus control is enabled the DRUH shall respond to all commands except INHIBIT and ENABLE AUXILIARY BUS CONTROL, received on the Auxiliary Bus. Should either of those commands be received on the Auxiliary Bus, the DRUH shall set ALERT DATA D5/1 (Invalid Command Received) and return a STATUS DATA message.

A.3.2 Host RS-422 commands and messages. Host RS-422 commands and associated DRUH response messages are listed in Table A-I along with the decimal representation of the command code and subcode, if applicable, message ID, and the minimum command acceptance rate. The INH column indicates whether the command is inhibited (yes) or not (no) when the Auxiliary Bus is inhibited.

Messages transmitted over the Host RS-422 data bus shall contain only mutually consistent samples of information. Any invalid data transmitted over the data bus shall be indicated as invalid within the same message the data appears.

TABLE A-I. Commands and messages.

COMMAND				RATE (Hz)	RESPONSE MESSAGE	
CODE	SUB	NAME	INH		ID	NAME
0		RETURN TRAVEL LOCK DATA	no	100	3	TRAVEL LOCK DATA
1		RETURN ATTITUDE DATA	no	100	2	ATTITUDE DATA
2		RESERVED				
3		ACCEPT CONFIGURATION DATA	yes	5	0	STATUS DATA
4		RESERVED				
5		ACCEPT POSITION	yes	5	0	STATUS DATA
6	xx	SUPPLIER RESERVED		12	xx	SUPPLIER RESERVED
7		RESET DISTANCE	yes	5	0	STATUS DATA
8		OVERRIDE ALERT	no	5	0	STATUS DATA
9		RETURN POSITION DATA	no	5	8	POSITION DATA
10		INHIBIT AUXILIARY BUS CONTROL	yes	5	0	STATUS DATA
11		ENABLE AUXILIARY BUS CONTROL	yes	5	0	STATUS DATA
12		RETURN POINTING DEVICE ATTITUDE DATA	no	100	10	POINTING DEVICE ATTITUDE DATA
13		RETURN POINTING DEVICE RATE DATA	no	100	11	POINTING DEVICE RATE DATA
14		RESERVED				
15		INHIBIT ZERO-VELOCITY UPDATE	yes	5	0	STATUS DATA
16		RETURN STATUS	no	5	0	STATUS DATA
17		RETURN NAVIGATION DATA	no	5	1	NAVIGATION DATA
18		RETURN ALIGN TIME TO GO	no	5	7	ALIGN TIME TO GO DATA
19		RETURN ALERT DATA	no	5	6	ALERT DATA
20	1	INHIBIT ODOMETER REQUEST	yes	5	0	STATUS DATA
20	2	ENABLE ODOMETER REQUEST	yes	5	0	STATUS DATA
20	5	IN TRAVEL LOCK	yes	5	0	STATUS DATA
20	6	OUT OF TRAVEL LOCK	yes	5	0	STATUS DATA
20	7	RETURN CONFIGURATION DATA	no	5	18	CONFIGURATION DATA
20	8	RETURN POINTING DEVICE BORESIGHT	no	5	13	POINTING DEVICE BORESIGHT DATA
20	10	RETURN SURVEY QUALITY	no	5	15	SURVEY QUALITY
20	11	ACCEPT VEHICLE BORESIGHT	yes	5	0	STATUS DATA
20	12	RETURN VEHICLE BORESIGHT	no	5	16	VEHICLE BORESIGHT
20	13	RETURN GEODETIC DATA	no	5	17	GEODETIC DATA
20	14	ACCEPT GEODETIC DATA	yes	5	0	STATUS DATA
20	15	STORED HEADING SHUTDOWN	yes	5	0	STATUS DATA
20	16	AIR TRANSPORT MODE REQUEST	yes	5	0	STATUS DATA
20	17	MARINE TRANSPORT MODE REQUEST	yes	5	0	STATUS DATA
20	18	TRANSPORT MODE COMPLETE	yes	5	0	STATUS DATA
21		ENABLE ZERO-VELOCITY UPDATE	yes	5	0	STATUS DATA
22	1	ACCEPT USER DATUM	yes	5	0	STATUS DATA
22	2	PASS GPS SETUP DATA	yes	5	0	STATUS DATA
22	3	PASS GPS DIFFERENTIAL CORRECTION	yes	5	0	STATUS DATA
22	4	ACCEPT HOST STATUS	yes	5	0	STATUS DATA

TABLE A-I. Commands and messages.

COMMAND				RATE (Hz)	RESPONSE MESSAGE	
CODE	SUB	NAME	INH		ID	NAME
22	5	ENABLE INERTIAL MODE	yes	5	0	STATUS DATA
22	6	ENABLE INTEGRATED MODE	yes	5	0	STATUS DATA
22	7	USE DEGRADED GPS DATA	yes	5	0	STATUS DATA
22	8	SELECT Y-CODE ONLY SATELLITES	yes	5	0	STATUS DATA
22	9	SELECT P OR Y-CODE SATELLITES	yes	5	0	STATUS DATA
22	10	DO NOT APPLY RELATIVE OFFSETS	yes	5	0	STATUS DATA
22	11	APPLY RELATIVE OFFSETS	yes	5	0	STATUS DATA
22	12	RESET RELATIVE OFFSETS	yes	5	0	STATUS DATA
22	19	RETURN DATUM DATA	no	5	19	DATUM DATA
22	20	RETURN GPS TIME & DAY	no	5	20	GPS TIME & DAY
22	21	RETURN GPS POSITION DATA	no	5	21	GPS POSITION DATA
22	22	RETURN GPS WARNING	no	5	22	GPS WARNING
22	23	RETURN NEXT GPS WARNING	no	5	22	GPS WARNING
22	24	RETURN PRECISION NAV DATA	no	5	24	PRECISION NAV DATA
22	25	RETURN DRUH S/W ID DATA	no	5	25	DRUH S/W ID DATA
23		ACCEPT POINTING DEVICE BORESIGHT	yes	5	0	STATUS DATA
26		RESTART	yes	5	0	STATUS DATA
27		STORED HEADING ALIGN	yes	5	0	STATUS DATA
30		SHUTDOWN	yes	5	0	STATUS DATA
31		RETURN BIT DATA	no	5	4	BIT DATA

A.3.2.1 RS-422 command and message data description. The requirements for data in RS-422 commands and messages are set forth in tables. Each row specifies the requirements for a data field.

A data field shall occupy the byte(s) specified in the BYTE(s) column. Unless otherwise specified, the field shall completely fill the byte(s) specified in the BYTE(s) column. When the field does not completely fill the bytes specified in the BYTE(s) column, the field length is specified in the BITS column.

The data format for the field is specified in the TYPE column and applies to the entire field, regardless of length. Available data types are listed in Table A-II.

TABLE A-II Data types.

TYPE	DESCRIPTION
ASCII	ASCII coded characters. Each character contains 8 bits.
dis	Discrete - Individual bit(s) having a value of 0 (reset) or 1 (set).
hex	Hexadecimal coded characters. Each character contains 4 bits.
sb	Signed Binary - The most significant bit represents the sign (0 = +, 1 = -). The rest of the field is Unsigned Binary.
ub	Unsigned Binary - The entire field is positive.
2b	Two's Complement Binary

The allowable range of values for a field is specified in the RANGE column. When a single value is given, it is the only permissible value.

All numeric fields are scaled binary. The resolution of the least significant bit is specified in the RES. column.

The units applicable to both the range and resolution are specified in the UNITS column.

The data to be input or output in the field is identified in the DATA ELEMENT column. Data elements are defined either within the table or elsewhere in this specification.

A.3.2.2 Host RS-422 command formats. The DRUH shall accept, for processing, input commands in the following format:

F C D1.....DN E1 E2 F

DESCRIPTION OF SYMBOLS

- a. F, Flag. The SDLC flag byte.
- b. C, Command. The command byte identifies the requested DRUH response. The command code consists of 5 bits as specified in the detailed command description. Some commands contain a subcode, in data byte D1, which further identifies the requested response. The command byte also contains a 3 bit message sequence number assigned by the host.

<u>MESSAGE</u> <u>SEQ. NO.</u>	<u>COMMAND</u> <u>CODE</u>
XXX	XXXXX
bit position 765	43210

The DRUH shall set ALERT DATA D5/0 (Undefined Command Received) and return a STATUS DATA message if an undefined command code or subcode is received.

- c. D1.....DN, Data. A command may contain 0 to 64 data bytes as specified in the detailed command description. The DRUH shall set ALERT DATA D5/0 (Undefined Command Received), not further process the command, and return a STATUS DATA message if a command is received with an incorrect number of bytes.
- d. E1, E2, error detection code. The two byte CRC.
- e. X, symbol. An X indicates a binary "1" or "0".

A.3.2.3 Host RS-422 command rates. The DRUH shall accept and process commands received on both Auxiliary and Main data busses simultaneously within the range of zero to the minimum command acceptance rates listed in Table A-I. The two combinations of commands that are required to be processed simultaneously are: (1) 5 HZ commands received on both busses; (2) a 5 HZ command received on one bus and a 100 HZ command received on the other bus.

The DRUH is not required to accept a new command on a particular bus until the message associated with a command previously received on that bus has been transmitted or until the required response time for the command previously received plus 10 milliseconds has elapsed with no message being sent.

A.3.2.4 Commands. Host RS-422 commands are described in the following subparagraphs. Unless otherwise specified, the DRUH shall perform the requested function(s) and return the message specified in Table A-I upon receipt of a command containing a valid command code.

A.3.2.4.1 RETURN TRAVEL LOCK DATA command.

Function: Requests the DRUH to send a TRAVEL LOCK DATA message.

<b>COMMAND CODE</b>	0 (00000b)	<b>DATA BYTE COUNT</b>	0
---------------------	------------	------------------------	---

A.3.2.4.2 RETURN ATTITUDE DATA command.

Function: Requests the DRUH to send an ATTITUDE DATA message.

<b>COMMAND CODE</b>	1 (00001b)	<b>DATA BYTE COUNT</b>	0
---------------------	------------	------------------------	---

A.3.2.4.3 ACCEPT CONFIGURATION DATA command.

Function: When the configuration code is 15, requests the DRUH to accept a configuration data update and tailor operation using the new configuration data. Configuration data elements are defined in Appendix C.

When the configuration code is not 15, the DRUH shall reject the command and set ALERT DATA D5/7 (Invalid Update Request).

<b>COMMAND CODE</b>	3 (00011b)	<b>DATA BYTE COUNT</b>	53
---------------------	------------	------------------------	----

BYTE(s)	BITs	TYPE	RANGE	RES.	UNITS	DATA ELEMENT
D1		2b	0	1	n/a	Reserved Spare
D2-D3		2b	-3199.9 to +3200.0	0.1	mil	1 - 2 Threshold Angle
D4-D5		2b	-3199.9 to +3200.0	0.1	mil	2 - 1 Threshold Angle
D6-D7		2b	-25.00 to +25.00	0.01	meter	Orientation 1 Vehicle ΔX
D8-D9		2b	-25.00 to +25.00	0.01	meter	Orientation 1 Vehicle ΔY
D10-D11		2b	-25.00 to +25.00	0.01	meter	Orientation 1 Vehicle ΔZ
D12-D13		2b	-25.00 to +25.00	0.01	meter	Orientation 2 PD ΔX
D14-D15		2b	-25.00 to +25.00	0.01	meter	Orientation 2 PD ΔY
D16-D17		2b	-25.00 to +25.00	0.01	meter	Orientation 2 PD ΔZ
D18-D19		ub	2 to 15	0.25	minute	Exclusive ZUPT mode ZUPT interval
D20-D21		ub	2 to 63	1	minute	Odometer Mode ZUPT interval
D22-D23		ub	3.5 to 34.0	0.25	minute	Static Align Time
D24-D25		ub	0 to 10 (0 valid only if D29/5 is reset)	1	second	Shot Detect Interval
D26-D29		dis	n/a	n/a	n/a	Configuration definition flags
D30-D31		ub	0.750 to 1.250	0.001	n/a	Odometer Scale Factor
D32-D33		2b	-3276.8 to +3276.7	0.1	μ-radian /km	Fuel Consumption Factor
D34		hex	00 to 3F	n/a	n/a	DRUH Coordinate Frame Code for Orientation 1
D35		hex	00 to 3F	n/a	n/a	DRUH Coordinate Frame Code for Orientation 2
D36-D37		2b	-25.00 to +25.00	0.01	meter	Odometer action point ΔX
D38-D39		2b	-25.00 to +25.00	0.01	meter	Odometer action point ΔY
D40-D41		2b	-25.00 to +25.00	0.01	meter	Odometer action point ΔZ
D42-D43		2b	-25.00 to +25.00	0.01	meter	GPS antenna ΔX
D44-D45		2b	-25.00 to +25.00	0.01	meter	GPS antenna ΔY
D46-D47		2b	-25.00 to +25.00	0.01	meter	GPS antenna ΔZ
D48-D49		ub	10 to 900	1	second	GPS Update Time-out Interval
D50-D51		ub	0 to 256	1	meter	GPS EPE Good Value
D52-D53		ub	0 to 32,535	1	meter	GPS EPE Poor Value

A.3.2.4.4 ACCEPT POSITION command.

Function: Requests the DRUH to accept a grid coordinate position update.

<b>COMMAND CODE</b>	5 (00101b)	<b>DATA BYTE COUNT</b>	17
---------------------	------------	------------------------	----

BYTE(s)	BITS	TYPE	RANGE	RES.	UNITS	DATA ELEMENT
D1-D3		ub	0 to 10,000,000	1	meter	Northing
D4-D5	15	2b	-1,000 to +10,000	1	meter	Altitude
D6	7	2b	-61 to +61	1	n/a	Extended Zone Number + = northern hemisphere - = southern hemisphere (DRUH shall ignore sign) ±61 = Normal Zone
D7	7	2b	-60 to +60	1	n/a	DRUH Hemisphere & Zone + = northern hemisphere - = southern hemisphere
D8 bits 5-7	3	dis	0	n/a	n/a	Spare Bits
D8 bit 4	1	dis	0 or 1	n/a	n/a	Determine Relative Offsets flag
D8 bits 0-3	4	ub	0 to 1	1	n/a	DRUH Grid 0 = BNG 1 = UTM
D9-D11	20	ub	0 to 999,9999	1	meter	Easting
D12-D17		ASCII	Valid Datum ID Code (Appendix G)	n/a	n/a	Datum ID Code

A.3.2.4.5 Command - RESET DISTANCE.

Function: Requests the DRUH to reset to zero the total accumulated distance traveled by the vehicle.

<b>COMMAND CODE</b>	7 (00111b)	<b>DATA BYTE COUNT</b>	0
---------------------	------------	------------------------	---

A.3.2.4.6 OVERRIDE ALERT command.

Function: Requests the DRUH to reset overrideable ALERT DATA bits.

<b>COMMAND CODE</b>	8 (01000b)	<b>DATA BYTE COUNT</b>	0
---------------------	------------	------------------------	---

A.3.2.4.7 Command - RETURN POSITION DATA.

Function: Requests the DRUH to send a POSITION DATA message.

<b>COMMAND CODE</b>	9 (01001b)	<b>DATA BYTE COUNT</b>	0
---------------------	------------	------------------------	---

A.3.2.4.8 INHIBIT AUXILIARY BUS CONTROL command.

Function: Requests the DRUH to inhibit Host RS-422 Auxiliary Bus control.

<b>COMMAND CODE</b>	10 (01010b)	<b>DATA BYTE COUNT</b>	0
---------------------	-------------	------------------------	---

A.3.2.4.9 ENABLE AUXILIARY BUS CONTROL command.

Function: Requests the DRUH to enable Host RS-422 Auxiliary Bus control.

<b>COMMAND CODE</b>	11 (01011b)	<b>DATA BYTE COUNT</b>	0
---------------------	-------------	------------------------	---

A.3.2.4.10 RETURN POINTING DEVICE ATTITUDE DATA command.

Function: Requests the DRUH to send a POINTING DEVICE ATTITUDE DATA message.

<b>COMMAND CODE</b>	12 (01100b)	<b>DATA BYTE COUNT</b>	0
---------------------	-------------	------------------------	---

A.3.2.4.11 RETURN POINTING DEVICE RATE DATA command.

Function: Requests the DRUH to send a POINTING DEVICE RATE DATA message.

<b>COMMAND CODE</b>	13 (01101b)	<b>DATA BYTE COUNT</b>	0
---------------------	-------------	------------------------	---

A.3.2.4.12 INHIBIT ZERO VELOCITY UPDATES command.

Function: Requests the DRUH to inhibit zero-velocity updates while in Survey. The DRUH shall not request stops when ZUPT aiding is inhibited.

During Align, Air Transport and Marine Transport, the DRUH shall retain the current ZUPT aiding state and set ALERT DATA D5/6 (Invalid Mode Request).

<b>COMMAND CODE</b>	15 (01111b)	<b>DATA BYTE COUNT</b>	0
---------------------	-------------	------------------------	---

A.3.2.4.13 RETURN STATUS command.

Function: Requests the DRUH to send a STATUS DATA message.

<b>COMMAND CODE</b>	16 (10000b)	<b>DATA BYTE COUNT</b>	0
---------------------	-------------	------------------------	---

A.3.2.4.14 RETURN NAVIGATION DATA command.

Function: Requests the DRUH to send a NAVIGATION DATA message.

<b>COMMAND CODE</b>	17 (10001b)	<b>DATA BYTE COUNT</b>	0
---------------------	-------------	------------------------	---

A.3.2.4.15 RETURN ALIGN TIME TO GO command.

Function: Requests the DRUH to send an ALIGN TIME TO GO message.

<b>COMMAND CODE</b>	18 (10010b)	<b>DATA BYTE COUNT</b>	0
---------------------	-------------	------------------------	---

A.3.2.4.16 RETURN ALERT DATA command.

Function: Requests the DRUH to send an ALERT DATA message.

<b>COMMAND CODE</b>	19 (10011b)	<b>DATA BYTE COUNT</b>	0
---------------------	-------------	------------------------	---

A.3.2.4.17 INHIBIT ODOMETER REQUEST command.

Function: Requests the DRUH to inhibit using VMS data.

When the Odometer Installed flag (CFIG D29/0) is set and STATUS DATA S3/2 (DRUH In Motion) is reset, the DRUH shall: inhibit VMS aiding; inhibit VMS hardware and software BIT; and reset BIT DATA D2/0 (VMS Drive Fail) and D2/1 (VMS Fail).

When the Odometer Installed flag (CFIG D29/0) is reset or STATUS DATA S3/2 (DRUH In Motion) is set or in Air or Marine Transport, the current VMS aiding state shall be maintained and ALERT DATA D5/6 (Invalid Mode Request) shall be set.

<b>COMMAND CODE</b>	20 (10100b)	<b>DATA BYTE COUNT</b>	1
---------------------	-------------	------------------------	---

BYTE(s)	BITs	TYPE	RANGE	RES.	UNITS	DATA ELEMENT
D1		ub	1	1	n/a	Command Subcode

A.3.2.4.18 ENABLE ODOMETER REQUEST command.

Function: Requests the DRUH to perform VMS BIT and use VMS data.

When the Odometer Installed flag (CONFIG D29/0) is set and STATUS DATA S3/2 (DRUH In Motion) is reset, VMS hardware BIT shall be initiated. If the VMS fails BIT, VMS aiding shall be inhibited and STATUS DATA S1/3 (VMS Inhibited) shall be set. If the VMS passes BIT: BIT DATA D2/1 (VMS Fail) and D2/0 (VMS Drive Fail) shall be reset; STATUS DATA S1/3 (VMS Inhibited) shall be reset; and VMS aiding and BIT shall be enabled.

When the Odometer Installed flag (CONFIG D29/0) is reset or STATUS DATA S3/2 (DRUH In Motion) is set or in Air or Marine Transport, the current VMS aiding state shall be maintained and ALERT DATA D5/6 (Invalid Mode Request) shall be set.

<b>COMMAND CODE</b>	20 (10100b)	<b>DATA BYTE COUNT</b>	1
---------------------	-------------	------------------------	---

BYTE(s)	BITS	TYPE	RANGE	RES.	UNITS	DATA ELEMENT
D1		ub	2	1	n/a	Command Subcode

A.3.2.4.19 IN TRAVEL LOCK command.

Function: Indicates the DRUH is stowed for travel.

<b>COMMAND CODE</b>	20 (10100b)	<b>DATA BYTE COUNT</b>	1
---------------------	-------------	------------------------	---

BYTE(s)	BITS	TYPE	RANGE	RES.	UNITS	DATA ELEMENT
D1		ub	5	1	n/a	Command Subcode

A.3.2.4.20 OUT OF TRAVEL LOCK command.

Function: Indicates the DRUH is not stowed for travel.

<b>COMMAND CODE</b>	20 (10100b)	<b>DATA BYTE COUNT</b>	1
---------------------	-------------	------------------------	---

BYTE(s)	BITS	TYPE	RANGE	RES.	UNITS	DATA ELEMENT
D1		ub	6	1	n/a	Command Subcode

A.3.2.4.21 RETURN CONFIGURATION DATA command.

Function: Requests the DRUH to send a CONFIGURATION DATA message.

<b>COMMAND CODE</b>	20 (10100b)	<b>DATA BYTE COUNT</b>	1
---------------------	-------------	------------------------	---

BYTE(s)	BITS	TYPE	RANGE	RES.	UNITS	DATA ELEMENT
D1		ub	7	1	n/a	Command Subcode

A.3.2.4.22 RETURN POINTING DEVICE BORESIGHT command.

Function: Requests the DRUH to send a POINTING DEVICE BORESIGHT message.

<b>COMMAND CODE</b>	20 (10100b)	<b>DATA BYTE COUNT</b>	1
---------------------	-------------	------------------------	---

BYTE(s)	BITS	TYPE	RANGE	RES.	UNITS	DATA ELEMENT
D1		ub	8	1	n/a	Command Subcode

A.3.2.4.23 RETURN SURVEY QUALITY command.

Function: Requests the DRUH to send a SURVEY QUALITY message.

In Marine Transport, or in flight while in Air Transport, the DRUH shall reject the command and set ALERT DATA D5/5 (Invalid Data Request) if DRUH performance wouldn't be accurately reflected in the SURVEY QUALITY message.

<b>COMMAND CODE</b>	20 (10100b)	<b>DATA BYTE COUNT</b>	1
---------------------	-------------	------------------------	---

BYTE(s)	BITS	TYPE	RANGE	RES.	UNITS	DATA ELEMENT
D1		ub	10	1	n/a	Command Subcode

A.3.2.4.24 ACCEPT VEHICLE BORESIGHT command.

Function: If the Vehicle Boresight Angles flag (CFIG D29/6) is set, requests the DRUH to accept a vehicle boresight angles update. Boresight angle parameters are defined in Appendix C.

If the Vehicle Boresight Angles flag (CFIG D29/6) is reset, the DRUH shall reject the command and set ALERT DATA D5/7 (Invalid Update Request).

<b>COMMAND CODE</b>	20 (10100b)	<b>DATA BYTE COUNT</b>	7
---------------------	-------------	------------------------	---

BYTE(s)	BITS	TYPE	RANGE	RES.	UNITS	DATA ELEMENT
D1		ub	11	1	n/a	Command Subcode
D2-D3		ub	0 to 6399.9	0.1	mil	Vehicle $\alpha$
D4-D5		2b	-1600.0 to +1600.0	0.1	mil	Vehicle $\beta$
D6-D7		2b	-3199.9 to 3200.0	0.1	mil	Vehicle $\gamma$

A.3.2.4.25 RETURN VEHICLE BORESIGHT command.

Function: Requests the DRUH to send a VEHICLE BORESIGHT message.

<b>COMMAND CODE</b>	20 (10100b)	<b>DATA BYTE COUNT</b>	1
---------------------	-------------	------------------------	---

BYTE(s)	BITs	TYPE	RANGE	RES.	UNITS	DATA ELEMENT
D1		ub	12	1	n/a	Command Subcode

A.3.2.4.26 RETURN GEODETIC DATA command.

Function: Requests the DRUH to send a GEODETIC DATA message.

<b>COMMAND CODE</b>	20 (10100b)	<b>DATA BYTE COUNT</b>	1
---------------------	-------------	------------------------	---

BYTE(s)	BITs	TYPE	RANGE	RES.	UNITS	DATA ELEMENT
D1		ub	13	1	n/a	Command Subcode

A.3.2.4.27 ACCEPT GEODETIC DATA command.

Function: Requests the DRUH to accept a geodetic coordinate position update.

<b>COMMAND CODE</b>	20 (10100b)	<b>DATA BYTE COUNT</b>	25
---------------------	-------------	------------------------	----

BYTE(s)	BITs	TYPE	RANGE	RES.	UNITS	DATA ELEMENT
D1		ub	14	1	n/a	Command Subcode
D2		2b	0	1	n/a	Reserved Spare
D3 bits 5-7	3	dis	0	n/a	n/a	Spare Bits
D3 bit 4	1	dis	0 or 1	n/a	n/a	Determine Relative Offsets input flag
D3 bits 0-3	4	ub	0 to 1	1	n/a	DRUH Grid 0 = BNG 1 = UTM
D4-D5		sb	-90 to +90	1	degree	Latitude Degrees * + = Northern hemisphere - = Southern hemisphere
D6-D9		ub	0 to (60 - 1/2 <sup>24</sup> )	1/2 <sup>24</sup>	arc minute	Latitude Minutes *
D10-D11		sb	-180 to +180	1	degree	Longitude Degrees * + = East of Prime Meridian - = West of Prime Meridian
D12-D15		ub	0 to (60 - 1/2 <sup>24</sup> )	1/2 <sup>24</sup>	arc minute	Longitude Minutes *
D16-D19		2b	-1,000 to +10,000	0.01	meter	Altitude
D20-D25		ASCII	Valid Datum ID Code (Appendix G)	n/a	n/a	Datum ID Code

- \* In addition to the individual field range limits for degrees and minutes, the combination of degrees and minutes shall not exceed the degrees field range limits for latitude and longitude, respectively.

A.3.2.4.28 STORED HEADING SHUTDOWN command.

Function: Requests the DRUH to: save current position, attitude, and any other data necessary to initiate normal operation when the DRUH is next energized; and automatically enter Accelerated Align at the next turn-on.

The command shall be rejected and ALERT DATA D3/7 (Motion During Shutdown Request) set if STATUS DATA S3/2 (DRUH in Motion) is set when the command is received. ALERT DATA D2/0 (Shutdown Interrupt) shall be set if STATUS DATA S3/2 (DRUH in Motion) is set when the command is being processed. The command shall be rejected and ALERT DATA D3/4 (Insufficient Align Time) set if a STORED HEADING SHUTDOWN command is received prior to completing a Static Align or accumulating a total of 15 minutes stationary time after starting Accelerated Align.

<b>COMMAND CODE</b>	20 (10100b)	<b>DATA BYTE COUNT</b>	1
---------------------	-------------	------------------------	---

BYTE(s)	BITs	TYPE	RANGE	RES.	UNITS	DATA ELEMENT
D1		ub	15	1	n/a	Command Subcode

A.3.2.4.29 AIR TRANSPORT MODE REQUEST command.

Function: If STATUS DATA S1/5 (DRUH in Align) and S3/2 (DRUH In Motion) and S4/0 (DRUH In Marine Transport) are reset, and S1/4 (Ok to Move) is set, the DRUH shall: inhibit VMS aiding; set STATUS DATA S1/3 (VMS Inhibited) and S4/1 (DRUH in Air Transport Mode); and enter Air Transport.

If STATUS DATA S1/5 (DRUH in Align) or S3/2 (DRUH In Motion) or S4/0 (DRUH In Marine Transport) is set, or S1/4 (Ok to Move) is reset, the DRUH shall: remain in the current mode; and set ALERT DATA D5/6 (Invalid Mode Request).

<b>COMMAND CODE</b>	20 (10100b)	<b>DATA BYTE COUNT</b>	1
---------------------	-------------	------------------------	---

BYTE(s)	BITs	TYPE	RANGE	RES.	UNITS	DATA ELEMENT
D1		ub	16	1	n/a	Command Subcode

A.3.2.4.30 MARINE TRANSPORT MODE REQUEST command.

Function: If STATUS DATA S1/5 (DRUH in Align) and S3/2 (DRUH In Motion) and S4/1 (DRUH In Air Transport) are reset, and S1/4 (Ok to Move) is set, the DRUH shall: inhibit VMS aiding; inhibit ZUPTs; inhibit ZUPT requests; set STATUS DATA S1/3 (VMS Inhibited), S3/4 (ZUPTs Inhibited), and S4/0 (DRUH in Marine Transport Mode); and enter Marine Transport.

If STATUS DATA S1/5 (DRUH in Align) or S3/2 (DRUH In Motion) or S4/1 (DRUH In Air Transport) is set, or S1/4 (Ok to Move) is reset, the DRUH shall: remain in the current mode; and set ALERT DATA D5/6 (Invalid Mode Request).

<b>COMMAND CODE</b>	20 (10100b)	<b>DATA BYTE COUNT</b>	1
---------------------	-------------	------------------------	---

BYTE(s)	BITs	TYPE	RANGE	RES.	UNITS	DATA ELEMENT
D1		ub	17	1	n/a	Command Subcode

A.3.2.4.31 TRANSPORT MODE COMPLETE command.

Function: While in Air or Marine Transport, the DRUH shall: reset STATUS DATA S4/0 (DRUH in Marine Transport Mode), S4/1 (DRUH in Air Transport Mode) and S3/4 (ZUPTs Inhibited); enable ZUPTs and ZUPT requests; release altitude, if fixed; reset STATUS DATA S3/0 (Inertial Altitude Fixed); and, if VMS aiding was enabled prior to transport, enable VMS aiding and reset STATUS S1/3 (VMS Inhibited). The DRUH may set STATUS DATA S1/1 (Position Update Request) if useable GPS data are not available.

The DRUH may regard the TRANSPORT MODE COMPLETE command as an indication the host is stationary. If the DRUH is unable to restore normal motion detection after transport complete processing has been completed, ALERT DATA D4/1 (Excessive Rates) shall be set.

If in neither Air or Marine Transport, the DRUH shall reject the command and set ALERT DATA D5/6 (Invalid Mode Request).

<b>COMMAND CODE</b>	20 (10100b)	<b>DATA BYTE COUNT</b>	1
---------------------	-------------	------------------------	---

BYTE(s)	BITs	TYPE	RANGE	RES.	UNITS	DATA ELEMENT
D1		ub	18	1	n/a	Command Subcode

A.3.2.4.32 ENABLE ZERO-VELOCITY UPDATES command.

Function: Requests the DRUH to enable zero-velocity updates while in survey.

During Align, Air Transport and Marine Transport, the DRUH shall retain the current ZUPT aiding state and set ALERT DATA D5/6 (Invalid Mode Request).

<b>COMMAND CODE</b>	21 (10101b)	<b>DATA BYTE COUNT</b>	0
---------------------	-------------	------------------------	---

A.3.2.4.33 ACCEPT USER DATUM command.

Function: Requests the DRUH to retain the input data for use as USER1 or USER2 datum parameters, corresponding to the validity flag. Acceptance of this command shall not change the datum parameters currently used by the DRUH. (For the DRUH to use newly entered user datum parameters, the host must send a position update command containing the appropriate Datum ID.)

The user defined datum parameters are delta values (WGS 84 minus local datum).

<b>COMMAND CODE</b>	22 (10110b)	<b>DATA BYTE COUNT</b>	40
---------------------	-------------	------------------------	----

BYTE(s)	BITS	TYPE	RANGE	RES.	UNITS	DATA ELEMENT
D1		ub	1	1	n/a	Command Subcode
D2-D7		ASCII	Valid Datum ID Code (Appendix G)	n/a	n/a	Datum ID Code
D8-D11		2b	±2000.000	0.001	meter	User datum delta-a *
D12-D15		2b	±2000.000	0.001	n/a	User datum delta-f x10E7 *
D16-D17		2b	±2000.0	0.1	meter	User datum delta-x *
D18-D19		2b	±2000.0	0.1	meter	User datum delta-y *
D20-D21		2b	±2000.0	0.1	meter	User datum delta-z *
D22-D23		ub	0 to 26	1	n/a	MGRS Row Advance *
D24-D39		ASCII	See Appendix G	n/a	n/a	Datum Descriptor
D40		ub	0 thru 2	1	n/a	User Datum Validity: 0 = data not valid, 1 = data valid, DRUH USER1 2 = data valid, DRUH USER2

- \* When the GPS Installed flag (CFIG D27/7) is set, the DRUH shall send these data elements to the GPS receiver via GPS message #5038 (User Datums). The GPS receiver range limits may differ from those of the DRUH. If so, data outside the GPS receiver range limits may cause ALERT D1/6 (Datums Do Not Agree) to occur.

A.3.2.4.34 PASS GPS SETUP DATA command.

Function: Requests the DRUH to send setup data to the GPS receiver via GPS Message #5030 (Setup Data). The DRUH maintains control of Code Type and Elevation Hold Type and may override data input in this command.

<b>COMMAND CODE</b>	22 (10110b)	<b>DATA BYTE COUNT</b>	31
---------------------	-------------	------------------------	----

BYTE(s)	BITs	TYPE	RANGE	RES.	UNITS	DATA ELEMENT
D1		ub	2	1	n/a	Command Subcode
D2-D3	*	*	*	*	*	Validity (Word 5)
D4-D5	*	*	*	*	*	Code Type (Word 6)
D6-D7	*	*	*	*	*	Coordinate Reference (Word 7)
D8-D9	*	*	*	*	*	Distance Units (Word 8)
D10-D11	*	*	*	*	*	Elevation Units (Word 9)
D12-D13	*	*	*	*	*	Elevation Reference (Word 10)
D14-D15	*	*	*	*	*	Angular Units (Word 11)
D16-D17	*	*	*	*	*	North Reference (Word 12)
D18-D19	*	*	*	*	*	MVAR Type (Word 13)
D20-D21	*	*	*	*	*	Entered MVAR (Word 14)
D22-D23	*	*	*	*	*	Entered MVAR (Word 15)
D24-D25	*	*	*	*	*	Navigation Type (Word 16)
D26-D27	*	*	*	*	*	Elevation Hold Type (Word 17)
D28-D29	*	*	*	*	*	Time Reference (Word 18)
D30-D31	*	*	*	*	*	Error Units (Word 19)

- \* Shall be as specified in ICD-GPS-153 for message #5030 (Setup Data) for the data elements and words listed in the DATA ELEMENT column.

A.3.2.4.35 PASS GPS DIFFERENTIAL CORRECTIONS command.

Function: Requests the DRUH to send Differential GPS (DGPS) corrections to the GPS receiver via GPS Message #260 (Differential Corrections).

<b>COMMAND CODE</b>	22 (10110b)	<b>DATA BYTE COUNT</b>	41
---------------------	-------------	------------------------	----

BYTE(s)	BITs	TYPE	RANGE	RES.	UNITS	DATA ELEMENT
D1		ub	3	1	n/a	Command Subcode
D2-D3	*	*	*	*	*	Bytes 1 and 2 of data (Word 1)
D4-D5	*	*	*	*	*	Bytes 3 and 4 of data (Word 2)
D6-D7	*	*	*	*	*	Bytes 5 and 6 of data (Word 3)
D8-D9	*	*	*	*	*	Bytes 7 and 8 of data (Word 4)
D10-D11	*	*	*	*	*	Bytes 9 and 10 of data (Word 5)
D12-D13	*	*	*	*	*	Bytes 11 and 12 of data (Word 6)
D14-D15	*	*	*	*	*	Bytes 13 and 14 of data (Word 7)
D16-D17	*	*	*	*	*	Bytes 15 and 16 of data (Word 8)
D18-D19	*	*	*	*	*	Bytes 17 and 18 of data (Word 9)
D20-D21	*	*	*	*	*	Bytes 19 and 20 of data (Word 10)
D22-D23	*	*	*	*	*	Bytes 21 and 22 of data (Word 11)
D24-D25	*	*	*	*	*	Bytes 23 and 24 of data (Word 12)
D26-D27	*	*	*	*	*	Bytes 25 and 26 of data (Word 13)
D28-D29	*	*	*	*	*	Bytes 27 and 28 of data (Word 14)
D30-D31	*	*	*	*	*	Bytes 29 and 30 of data (Word 15)
D32-D33	*	*	*	*	*	Bytes 31 and 32 of data (Word 16)
D34-D35	*	*	*	*	*	Bytes 33 and 34 of data (Word 17)
D36-D37	*	*	*	*	*	Bytes 35 and 36 of data (Word 18)
D38-D39	*	*	*	*	*	Bytes 37 and 38 of data (Word 19)
D40-D41	*	*	*	*	*	Bytes 39 and 40 of data (Word 20)

\* Shall be as specified in ICD-GPS-153 for GPS message #260 (Differential Corrections) for the data elements and words listed in the DATA ELEMENT column.

**NOTE:** More than one PASS GPS DIFFERENTIAL CORRECTIONS command may be required to transmit an entire RTCM DGPS data set to the DRUH and GPS receiver. Unused bytes following the last DGPS data byte in this command should be filled with "00000000".

A.3.2.4.36 ACCEPT HOST STATUS command.

Function: Requests the DRUH to set or reset Host Status A and B STATUS DATA bits to the values in D2.

<b>COMMAND CODE</b>	22 (10110b)	<b>DATA BYTE COUNT</b>	2
---------------------	-------------	------------------------	---

BYTE(s)	BITs	TYPE	RANGE	RES.	UNITS	DATA ELEMENT
D1		ub	4	1	n/a	Command Subcode
D2 bits 2-7	6	dis	0	1	n/a	Spare bits
D2 bit 1	1	dis	0 or 1	1	n/a	Host Status B
D2 bit 0	1	dis	0 or 1	1	n/a	Host Status A

**NOTE:** STATUS DATA S5/1 (Host Status A) and S5/0 (Host Status B) allow host devices to communicate with each other through the DRUH. For example, the host may use them, in conjunction with S4/6 (1553 Bus Active) and S4/5 (Host RS-422 Bus Active), to signal that one host device asserts master control of the DRUH.

A.3.2.4.37 ENABLE INERTIAL MODE command.

Function: Requests the DRUH to inhibit use of GPS aiding.

If the GPS Installed flag (CFG D27/7) is set, the DRUH shall: inhibit GPS aiding; and reset STATUS DATA S5/6 (GPS Enabled) unless [GPS aiding is enabled, and the DRUH is in Dynamic Align, and STATUS DATA S1/4 (OK To Move) is reset, and STATUS DATA S3/2 (DRUH In Motion) is set]. In which case the DRUH shall: keep GPS aiding enabled; and set ALERT DATA D5/6 (Invalid Mode Request).

If the GPS Installed flag (CFG D27/7) is reset, the DRUH shall: inhibit GPS aiding; and set ALERT DATA D5/6 (Invalid Mode Request).

<b>COMMAND CODE</b>	22 (10110b)	<b>DATA BYTE COUNT</b>	1
---------------------	-------------	------------------------	---

BYTE(s)	BITs	TYPE	RANGE	RES.	UNITS	DATA ELEMENT
D1		ub	5	1	n/a	Command Subcode

A.3.2.4.38 ENABLE INTEGRATED MODE command.

Function: Requests the DRUH to enable use of GPS aiding.

If the GPS Installed flag (CFIG D27/7) is, the DRUH shall determine BIT status of the GPS receiver, antenna, and communications link. If BIT passes, the DRUH shall: enable GPS aiding; and set STATUS DATA S5/6 (GPS Enabled). If BIT fails, the DRUH shall: inhibit GPS aiding; reset STATUS DATA S5/6 (GPS Enabled); and set ALERT DATA D5/6 (Invalid Mode Request).

If the GPS Installed flag (CFIG D27/7) is reset, the DRUH shall: inhibit GPS aiding; and set ALERT DATA D5/6 (Invalid Mode Request).

<b>COMMAND CODE</b>	22 (10110b)	<b>DATA BYTE COUNT</b>	1
---------------------	-------------	------------------------	---

BYTE(s)	BITs	TYPE	RANGE	RES.	UNITS	DATA ELEMENT
D1		ub	6	1	n/a	Command Subcode

A.3.2.4.39 USE DEGRADED GPS DATA command.

Function: Requests the DRUH to accept GPS updates when STATUS DATA S6/0 (EPE ≤ GPS Poor Level) is set and S6/1 (EPE ≤ GPS Good Level) is reset.

<b>COMMAND CODE</b>	22 (10110b)	<b>DATA BYTE COUNT</b>	1
---------------------	-------------	------------------------	---

BYTE(s)	BITs	TYPE	RANGE	RES.	UNITS	DATA ELEMENT
D1		ub	7	1	n/a	Command Subcode

A.3.2.4.40 SELECT Y-CODE ONLY SATELLITES command.

Function: Requests the DRUH to command the GPS receiver to use only Y-code satellites for GPS data.

<b>COMMAND CODE</b>	22 (10110b)	<b>DATA BYTE COUNT</b>	1
---------------------	-------------	------------------------	---

BYTE(s)	BITs	TYPE	RANGE	RES.	UNITS	DATA ELEMENT
D1		ub	8	1	n/a	Command Subcode

A.3.2.4.41 SELECT P OR Y-CODE SATELLITES command.

Function: Requests the DRUH to command the GPS receiver to use either P-code or Y-code satellites for GPS data.

<b>COMMAND CODE</b>	22 (10110b)	<b>DATA BYTE COUNT</b>	1
---------------------	-------------	------------------------	---

BYTE(s)	BITs	TYPE	RANGE	RES.	UNITS	DATA ELEMENT
D1		ub	9	1	n/a	Command Subcode

A.3.2.4.42 DO NOT APPLY RELATIVE OFFSETS command.

Function: When received, the DRUH shall reset the Relative Offsets Applied flag and provide positions without relative offsets applied whenever position data are requested.

<b>COMMAND CODE</b>	22 (10110b)	<b>DATA BYTE COUNT</b>	1
---------------------	-------------	------------------------	---

BYTE(s)	BITS	TYPE	RANGE	RES.	UNITS	DATA ELEMENT
D1		ub	10	1	n/a	Command Subcode

A.3.2.4.43 APPLY RELATIVE OFFSETS command.

Function: When received, the DRUH shall set the Relative Offsets Applied flag and provide offset positions whenever position data are requested.

<b>COMMAND CODE</b>	22 (10110b)	<b>DATA BYTE COUNT</b>	1
---------------------	-------------	------------------------	---

BYTE(s)	BITS	TYPE	RANGE	RES.	UNITS	DATA ELEMENT
D1		ub	11	1	n/a	Command Subcode

A.3.2.4.44 RESET RELATIVE OFFSETS command.

Function: When received, the DRUH shall set the relative offsets to zero and reset STATUS DATA S2/0 (Relative Offsets Determined).

<b>COMMAND CODE</b>	22 (10110b)	<b>DATA BYTE COUNT</b>	1
---------------------	-------------	------------------------	---

BYTE(s)	BITS	TYPE	RANGE	RES.	UNITS	DATA ELEMENT
D1		ub	12	1	n/a	Command Subcode

A.3.2.4.45 RETURN DATUM DATA command.

Function: Requests the DRUH to send a DATUM DATA message.

<b>COMMAND CODE</b>	22 (10110b)	<b>DATA BYTE COUNT</b>	2
---------------------	-------------	------------------------	---

BYTE(s)	BITS	TYPE	RANGE	RES.	UNITS	DATA ELEMENT
D1		ub	19	1	n/a	Command Subcode
D2		ub	0-64	1	n/a	Number of Datum to be returned: 0 = DRUH Datum In Use 1 thru 60 = DRUH preprogrammed Datums 61 = DRUH USER1 Datum 62 = DRUH USER2 Datum 63 = GPS USER1 Datum 64 = GPS USER2 Datum

A.3.2.4.46 RETURN GPS TIME & DAY command.

Function: Requests the DRUH to send a GPS TIME & DAY message.

<b>COMMAND CODE</b>	22 (10110b)	<b>DATA BYTE COUNT</b>	1
---------------------	-------------	------------------------	---

BYTE(s)	BITs	TYPE	RANGE	RES.	UNITS	DATA ELEMENT
D1		ub	20	1	n/a	Command Subcode

A.3.2.4.47 RETURN GPS POSITION DATA command.

Function: Requests the DRUH to send a GPS POSITION DATA message.

<b>COMMAND CODE</b>	22 (10110b)	<b>DATA BYTE COUNT</b>	1
---------------------	-------------	------------------------	---

BYTE(s)	BITs	TYPE	RANGE	RES.	UNITS	DATA ELEMENT
D1		ub	21	1	n/a	Command Subcode

A.3.2.4.48 RETURN GPS WARNING command.

Function: Requests the DRUH to send the currently queued GPS warning in a GPS WARNING message.

<b>COMMAND CODE</b>	22 (10110b)	<b>DATA BYTE COUNT</b>	1
---------------------	-------------	------------------------	---

BYTE(s)	BITs	TYPE	RANGE	RES.	UNITS	DATA ELEMENT
D1		ub	22	1	n/a	Command Subcode

A.3.2.4.49 RETURN NEXT GPS WARNING command.

Function: Requests the DRUH to delete the current GPS warning, and queue and send the next GPS warning in a GPS WARNING message.

<b>COMMAND CODE</b>	22 (10110b)	<b>DATA BYTE COUNT</b>	1
---------------------	-------------	------------------------	---

BYTE(s)	BITs	TYPE	RANGE	RES.	UNITS	DATA ELEMENT
D1		ub	23	1	n/a	Command Subcode

A.3.2.4.50 RETURN PRECISION NAVIGATION DATA command.

Function: Requests the DRUH to send a PRECISION NAVIGATION DATA message.

<b>COMMAND CODE</b>	22 (10110b)	<b>DATA BYTE COUNT</b>	1
---------------------	-------------	------------------------	---

BYTE(s)	BITs	TYPE	RANGE	RES.	UNITS	DATA ELEMENT
D1		ub	24	1	n/a	Command Subcode

A.3.2.4.51 RETURN DRUH S/W IDENTIFICATION DATA command.

Function: Requests the DRUH to send a DRUH S/W IDENTIFICATION DATA message.

<b>COMMAND CODE</b>	22 (10110b)	<b>DATA BYTE COUNT</b>	1
---------------------	-------------	------------------------	---

BYTE(s)	BITS	TYPE	RANGE	RES.	UNITS	DATA ELEMENT
D1		ub	25	1	n/a	Command Subcode

A.3.2.4.52 ACCEPT POINTING DEVICE BORESIGHT command.

Function: When the Pointing Device Boresight Angles flag (CFIG D29/7) is set, requests the DRUH to accept a pointing device boresight angles update. Boresight angle parameters are defined in Appendix C.

When the Pointing Device Boresight Angles flag (CFIG D29/7) is reset, the DRUH shall reject the command and set ALERT DATA D5/7 (Invalid Update Request).

<b>COMMAND CODE</b>	23 (10111b)	<b>DATA BYTE COUNT</b>	13
---------------------	-------------	------------------------	----

BYTE(s)	BITS	TYPE	RANGE	RES.	UNITS	DATA ELEMENT
D1		2b	0	1	n/a	Reserved Spare
D2-D3		ub	0 to 6399.9	0.1	mil	Pointing Device Orientation 1 A
D4-D5		2b	-1600.0 to +1600.0	0.1	mil	Pointing Device Orientation 1 B
D6-D7		2b	-3199.9 to +3200.0	0.1	mil	Pointing Device Orientation 1 Γ
D8-D9		ub	0 to 6399.9	0.1	mil	Pointing Device Orientation 2 A
D10-D11		2b	-1600.0 to +1600.0	0.1	mil	Pointing Device Orientation 2 B
D12-D13		2b	-3199.9 to 3200.0	0.1	mil	Pointing Device Orientation 2 Γ

A.3.2.4.53 RESTART command.

Function: Requests the DRUH to reinitiate Align. Upon receipt of a RESTART command the DRUH shall reinitialize within 2 seconds and perform Static Align or Dynamic Align.

When GPS aiding is inhibited, the DRUH shall accept a RESTART command only if STATUS DATA S3/2 (DRUH in Motion) is reset; or ALERT DATA D2/4 (Unable to Complete Align), or D2/3 (Align Interrupt), or D3/1 (Excessive Rates) is set.

When GPS aiding is enabled, the DRUH shall accept a RESTART command at any time.

<b>COMMAND CODE</b>	26 (11010b)	<b>DATA BYTE COUNT</b>	0
---------------------	-------------	------------------------	---

A.3.2.4.54 STORED HEADING ALIGN command.

Function: Requests the DRUH to enter Accelerated Align if received before 60 seconds of Static Align have been completed. The DRUH shall remain in the current mode and set ALERT DATA D5/6 (Invalid Mode Request) if a STORED HEADING ALIGN command is received when: the DRUH has been in Static Align more than 60 seconds; or the previous shutdown was abnormal; or a RESTART command was previously accepted; or ALERT DATA D2/3 (Align Interrupt) is set; or ALERT DATA D5/3 (Configuration Data Not Present) or D2/7 (Vehicle Boresight Angles Not Present) or D5/4 (Pointing Device Boresight Angles Not Present) was previously set.

<b>COMMAND CODE</b>	27 (11011b)	<b>DATA BYTE COUNT</b>	0
---------------------	-------------	------------------------	---

A.3.2.4.55 SHUTDOWN command.

Function: Requests the DRUH to save current position, attitude, and any other data necessary to initiate normal operation when the DRUH is next energized; and enter Static Align at the next turn-on.

ALERT DATA D3/7 (Motion During Shutdown Request) shall be set if STATUS DATA S3/2 (DRUH in Motion) is set when the command is received. ALERT DATA D1/0 (Previous Shutdown Abnormal) shall be set at the next turn-on if STATUS DATA S3/2 (DRUH in Motion) is set when the command is being processed.

<b>COMMAND CODE</b>	30 (11110b)	<b>DATA BYTE COUNT</b>	0
---------------------	-------------	------------------------	---

A.3.2.4.56 RETURN BIT DATA command.

Function: Requests the DRUH to send the BIT DATA message.

<b>COMMAND CODE</b>	31 (11111b)	<b>DATA BYTE COUNT</b>	0
---------------------	-------------	------------------------	---

A.3.2.5 Host RS-422 message response times. The DRUH shall complete transmission of a message in response to a 5 Hz command within 130 msec. The DRUH shall complete transmission of a message in response to a 100 Hz command within 9 msec. Response times are measured beginning with transmission of the first bit of the command by the host and ending with receipt of the last bit of the message by the host.

A.3.2.6 Host RS-422 message formats. The format of DRUH output messages shall be:

F I S1..S6 D1.....DN E1 E2 F

DESCRIPTION OF SYMBOLS

- a. F, Flag. The SDLC flag byte.
- b. I, identifier. The identifier byte shall indicate the type of message sent by the DRUH. The identifier code is 5 bits, as specified in the detailed message description. The identifier shall contain the 3 bit sequence number echoed from the initiating command. The complete message identifier can be used by the host to correlate responses with requests.

MESSAGE SEQ. NO.	IDENTIFIER CODE
XXX	XXXXX
bit position 765	43210

- c. S1.....S6, status data. Six bytes of STATUS DATA as specified in Appendix B.
- d. D1.....DN, Data. The data field shall contain 0 to 64 bytes of data as specified in the detailed message description.
- e. E1, E2, error detection code. The two byte CRC.
- f. X, symbol. An X indicates a binary "1" or "0".

A.3.2.7 Messages. Host RS-422 messages are described in the following subparagraphs. Message contents shall be as specified therein.

A.3.2.7.1 STATUS DATA message.

Function: Provides the current status of the DRUH.

<b>IDENTIFIER</b>	0 (00000b)	<b>DATA BYTE COUNT</b>	0
-------------------	------------	------------------------	---

A.3.2.7.2 NAVIGATION DATA message.

Function: Provides grid position, vehicle attitudes, and distance traveled data.

<b>IDENTIFIER</b>	1 (00001b)	<b>DATA BYTE COUNT</b>	28
-------------------	------------	------------------------	----

BYTE(s)	BITS	TYPE	RANGE	RES.	UNITS	DATA ELEMENT
D1-D3		ub	0 to 10,000,000	1	meter	Northing
D4-D5	15	2b	-16,384 to +16,383 **	1	meter	Altitude
D6-D8	17	ub	0 to 1,310,710 **	10	meter	Distance Traveled ***
D9-D10		ub	0 to 6,399.9	0.1	mil	Pointing Device Geodetic Azimuth or Grid Azimuth
D11-D12	15	2b	-1,638.4 to +1,638.3**	0.1	mil	Vehicle Roll or Cant
D13-D14	15	2b	-1600.0 to +1600.0	0.1	mil	Vehicle Pitch
D15-D16		ub	0 to 6,399.9	0.1	mil	Vehicle Geodetic or Grid Azimuth
D17 bits 5-7	3	dis	0	n/a	n/a	Spare Bits
D17 bit 4	1	dis	0 or 1	n/a	n/a	Relative Offsets Applied output flag
D17 bits 0-3	4	ub	0 to 1	1	n/a	Host (DRUH) Grid 0 = BNG 1 = UTM
D18-D20	20	ub	0 to 999,999 *	1	meter	Easting
D21	7	2b	-61 to +61	1	n/a	Extended Zone Number 61 = normal zone DRUH shall ignore sign
D22	7	2b	-60 to +60	1	n/a	DRUH Hemisphere & Zone + = northern hemisphere - = southern hemisphere
D23-D28		ASCII	Valid Datum ID Code (Appendix G)	n/a	n/a	Datum ID Code (6 ASCII Characters)

\* Actual limits are the UTM zone boundaries plus zone extension which are latitude and datum dependent.

\*\* For values outside the range, the output value shall be fixed at the appropriate positive or negative range limit.

\*\*\* Total distance traveled since turn-on or last RESET DISTANCE command. Distance Traveled may not accurately reflect the actual vehicle trajectory during Dynamic Align.

A.3.2.7.3 ATTITUDE DATA message.

Function: Provides Pointing Device geodetic or grid azimuth, Pointing Device Pitch; Vehicle pitch; Vehicle cant or roll; and Pointing Device azimuth and pitch rates.

<b>IDENTIFIER</b>	2 (00010b)	<b>DATA BYTE COUNT</b>	12
-------------------	------------	------------------------	----

BYTE(s)	BITS	TYPE	RANGE	RES.	UNITS	DESCRIPTION
D1-D2		ub	0 to 6,399.9	0.1	mil	Pointing Device Geodetic Azimuth or Grid Azimuth
D3-D4	15	2b	-1600.0 to +1600.0	0.1	mil	Pointing Device Pitch
D5-D6	15	2b	-1638.4 to +1638.3 *	0.1	mil	Vehicle Roll or Cant
D7-D8	15	2b	-1600.0 to +1600.0	0.1	mil	Vehicle Pitch
D9-D10		2b	-5898.24 to +5898.06 *	0.18	mil/sec	Pointing Device Azimuth Rate
D11-D12		2b	-5898.24 to +5898.06 *	0.18	mil/sec	Pointing Device Pitch Rate

\* For values outside the range, the output value shall be fixed at the appropriate positive or negative range limit.

A.3.2.7.4 TRAVEL LOCK DATA message.

Function: Provides Travel Lock Reference attitudes and associated data.

<b>IDENTIFIER</b>	3 (00011b)	<b>DATA BYTE COUNT</b>	12
-------------------	------------	------------------------	----

BYTE(s)	BITS	TYPE	RANGE	RES.	UNITS	DESCRIPTION
D1-D2		ub	0 to 6,399.9	0.1	mil	Pointing Device Geodetic Azimuth or Grid Azimuth
D3-D4	15	2b	-1600.0 to +1600.0	0.1	mil	Pointing Device Pitch
D5-D6		ub	0 to 6,399.9	0.1	mil	Travel Lock Pointing Device Geodetic or Grid Azimuth Reference
D7-D8		2b	-1600 to +1600	0.1	mil	Travel Lock Pointing Device Pitch Reference
D9-D10		2b	-5898.24 to +5898.06 *	0.18	mil/sec	Pointing Device Azimuth Rate
D11-D12		2b	-5898.24 to +5898.06 *	0.18	mil/sec	Pointing Device Pitch Rate

\* For values outside the range, the output value shall be fixed at the appropriate positive or negative range limit.

A.3.2.7.5 BUILT-IN-TEST (BIT) DATA message.

Function: Provides BIT status.

<b>IDENTIFIER</b>	4 (00100b)	<b>DATA BYTE COUNT</b>	2
-------------------	------------	------------------------	---

BYTE(s)	BITs	TYPE	RANGE	RES.	UNITS	DESCRIPTION
D1-D2		dis	n/a	n/a	n/a	BIT DATA per Appendix B

Spare BIT DATA bits shall be reset (= 0).

**NOTE:** Since spares may be activated in future revisions, host checking of spare BIT DATA bit values is not recommended.

A.3.2.7.6 ALERT DATA message.

Function: Provides DRUH ALERT DATA.

<b>IDENTIFIER</b>	6 (00110b)	<b>DATA BYTE COUNT</b>	6
-------------------	------------	------------------------	---

BYTE(s)	BITs	TYPE	RANGE	RES.	UNITS	DESCRIPTION
D1-D6		dis	n/a	n/a	n/a	ALERT DATA per Appendix B

Spare ALERT DATA bits shall be reset (= 0).

**NOTE:** Since spares may be activated in future revisions, host checking of spare ALERT DATA bit values is not recommended.

A.3.2.7.7 ALIGN TIME TO GO message.

Function: Indicates time remaining to complete Align related functions.

<b>IDENTIFIER</b>	7 (00111b)	<b>DATA BYTE COUNT</b>	2
-------------------	------------	------------------------	---

BYTE(s)	BITS	TYPE	RANGE	RES.	UNITS	DESCRIPTION
D1-D2	11	ub	0 to 2047	1	second	Align Time To Go *

- \* Align Time To Go shall be the time remaining to complete Accelerated, Static, or Dynamic Align. It shall be zero when: [Accelerated Align is complete and the Odometer Installed flag (CFIG D29/0) is reset]; or Static Align is complete; or Dynamic Align is complete; or Align has been terminated.

When Accelerated Align is complete and the Odometer Installed flag is set, Align Time To Go shall be the time remaining until VMS aiding can be used. It shall be zero when VMS aiding can be used.

Align Time To Go may be frozen when moving and GPS aided time isn't being accumulated.

A.3.2.7.8 POSITION DATA message.

Function: Provides grid position data.

<b>IDENTIFIER</b>	8 (01000b)	<b>DATA BYTE COUNT</b>	16
-------------------	------------	------------------------	----

BYTE(s)	BITS	TYPE	RANGE	RES.	UNITS	DATA ELEMENT
D1 bits 5-7	3	dis	0	n/a	n/a	Spare Bits
D1 bit 4	1	dis	0 or 1	n/a	n/a	Relative Offsets Applied output flag
D1 bits 0-3	4	ub	0 to 1	1	n/a	Host (DRUH) Grid 0 = BNG 1 = UTM
D2	7	2b	-60 to +60	1	n/a	DRUH Hemisphere & Zone + = northern hemisphere - = southern hemisphere
D3-D5	20	ub	0 to 999,999 *	1	meter	Easting
D6-D8		ub	0 to 10,000,000	1	meter	Northing
D9-D10	15	2b	-16,384 to +16,383 **	1	meter	Altitude
D11-D16		ASCII	Valid Datum ID Code (Appendix G)	n/a	n/a	Datum ID Code

- \* Actual limits are the UTM zone boundaries plus zone extension which are latitude and datum dependent.

- \*\* For values outside the range, the output value shall be fixed at the appropriate positive or negative range limit.

A.3.2.7.9 POINTING DEVICE ATTITUDE DATA message.

Function: Provides Pointing Device Attitude data.

<b>IDENTIFIER</b>	10 (01010b)	<b>DATA BYTE COUNT</b>	6
-------------------	-------------	------------------------	---

BYTE(s)	BITS	TYPE	RANGE	RES.	UNITS	DESCRIPTION
D1-D2		ub	0 to 6,399.9	0.1	mil	Pointing Device Geodetic Azimuth or Grid Azimuth
D3-D4		2b	-1600.0 to +1600.0	0.1	mil	Pointing Device Pitch
D5-D6		2b	-3199.9 to +3200.0	0.1	mil	Pointing Device Roll or Cant

A.3.2.7.10 POINTING DEVICE RATE DATA message.

Function: Provides Pointing Device angular rates.

<b>IDENTIFIER</b>	11 (01011b)	<b>DATA BYTE COUNT</b>	6
-------------------	-------------	------------------------	---

BYTE(s)	BITS	TYPE	RANGE	RES.	UNITS	DESCRIPTION
D1-D2		2b	-3276.8 to +3276.7 *	0.1	mil/sec	Pointing Device Azimuth Rate
D3-D4		2b	-3276.8 to +3276.7 *	0.1	mil/sec	Pointing Device Pitch Rate
D5-D6		2b	-3276.8 to +3276.7 *	0.1	mil/sec	Pointing Device Roll Rate

\* For values outside the range, the output value shall be fixed at the appropriate positive or negative range limit.

A.3.2.7.11 POINTING DEVICE BORESIGHT message.

Function: Provides Pointing Device boresight angle values. If the Pointing Device Boresight Present flag is reset, the data returned in a POINTING DEVICE BORESIGHT message may be invalid. Pointing Device Boresight angles are defined in Appendix C.

<b>IDENTIFIER</b>	13 (01101b)	<b>DATA BYTE COUNT</b>	12
-------------------	-------------	------------------------	----

BYTE(s)	BITS	TYPE	RANGE	RES.	UNITS	DATA ELEMENT
D1-D2		ub	0 to 6399.9	0.1	mil	Pointing Device Orient. 1 A
D3-D4		2b	-1600.0 to +1600.0	0.1	mil	Pointing Device Orient. 1 B
D5-D6		2b	-3199.9 to +3200.0	0.1	mil	Pointing Device Orient. 1 Γ
D7-D8		ub	0 to 6399.9	0.1	mil	Pointing Device Orient. 2 A
D9-D10		2b	-1600.0 to +1600.0	0.1	mil	Pointing Device Orient. 2 B
D11-D12		2b	-3199.9 to +3200.0	0.1	mil	Pointing Device Orient. 2 Γ

A.3.2.7.12 SURVEY QUALITY message.

Function: Provides the values of relative offsets and current DRUH estimates of DRUH position and azimuth errors.

<b>IDENTIFIER</b>	15 (01111b)	<b>DATA BYTE COUNT</b>	20
-------------------	-------------	------------------------	----

BYTE(s)	BITs	TYPE	RANGE	RES.	UNITS	DATA ELEMENT
D1-D2		ub	0 to 2047	0.0625	meter	DRUH Estimated Horizontal CEP
D3-D4		ub	0 to 2047	0.0625	meter	DRUH Estimated Vertical Probable Error
D5-D6		ub	0 to 2047	0.0625	meter	DRUH Estimated Heading Probable Error
D7-D8		ub	0 to 2047	0.0625	meter	Odometer Damped Horizontal CEP Specification (0.25 percent x distance traveled since last position update)
D9-D10		ub	0 to 2047	0.0625	meter	Odometer Damped Vertical Probable Error Specification (0.067 percent x distance traveled since last altitude update)
D11-D12		ub	0.1 to 10.0	0.0625	n/a	Estimated Horizontal Spec Multiplier
D13-D14		ub	0.1 to 10.0	0.0625	n/a	Estimated Vertical Spec Multiplier
D15-D16		2b	±2000.0	0.1	meter	North Relative Offset
D17-D18		2b	±2000.0	0.1	meter	East Relative Offset
D19-D20		2b	±2000.0	0.1	meter	Altitude Relative Offset

A.3.2.7.13 VEHICLE BORESIGHT message.

Function: Provides Vehicle Boresight angle values. If the Vehicle Boresight Present Flag is reset, the data returned in a VEHICLE BORESIGHT message may be invalid. Vehicle Boresight angles are defined in Appendix C.

<b>IDENTIFIER</b>	16 (10000b)	<b>DATA BYTE COUNT</b>	6
-------------------	-------------	------------------------	---

BYTE(s)	BITs	TYPE	RANGE	RES.	UNITS	DATA ELEMENT
D1-D2		ub	0 to 6399.9	0.1	mil	Vehicle $\alpha$
D3-D4		2b	-1600.0 to +1600.0	0.1	mil	Vehicle $\beta$
D5-D6		2b	-3199.9 to +3200.0	0.1	mil	Vehicle $\gamma$

A.3.2.7.14 GEODETIC DATA message.

Function: Provides geodetic position, altitude and velocity data.

<b>IDENTIFIER</b>	17 (10001b)	<b>DATA BYTE COUNT</b>	36
-------------------	-------------	------------------------	----

BYTE(s)	BITS	TYPE	RANGE	RES.	UNITS	DESCRIPTION
D1-D2		sb	-90 to +90	1	degree	Latitude Degrees * + = Northern hemisphere - = Southern hemisphere
D3-D6		ub	0 to (60 - 1/2 <sup>24</sup> )	1/2 <sup>24</sup>	arc minute	Latitude Minutes *
D7-D8		sb	-180 to +180	1	degree	Longitude Degrees * + = East of Prime Meridian - = West of Prime Meridian
D9-D12		ub	0 to (60 - 1/2 <sup>24</sup> )	1/2 <sup>24</sup>	arc minute	Longitude Minutes *
D13-D16		2b	-32,768 to +32,767	0.01	meter	Altitude
D17-D20		2b	-32,768 to +32,767	1/2 <sup>16</sup>	meter /sec	Velocity North
D21-D24		2b	-32,768 to +32,767	1/2 <sup>16</sup>	meter /sec	Velocity East
D25-D28		2b	-32,768 to +32,767	1/2 <sup>16</sup>	meter /sec	Velocity Up
D29		2b	0	1	n/a	Reserved Spare
D30 bits 5-7	3	dis	0	n/a	n/a	Spare Bits
D30 bit 4	1	dis	0 or 1	n/a	n/a	Relative Offsets Applied output flag
D30 bits 0-3	4	ub	0 to 1	1	n/a	Host (DRUH) Grid 0 = BNG 1 = UTM
D31-D36		ASCII	Valid Datum ID Code (Appendix G)	n/a	n/a	Datum ID Code

- \* In addition to the individual field range limits for degrees and seconds, the combination of degrees and minutes shall not exceed the degrees field range limit for latitude and longitude, respectively.

A.3.2.7.15 CONFIGURATION DATA message.

Function: Provides the configuration data presently used by the DRUH. If the Configuration Data Present flag is reset, the data returned in a CONFIGURATION DATA message may be invalid. Configuration data elements are defined in Appendix C.

<b>IDENTIFIER</b>	18 (10010b)	<b>DATA BYTE COUNT</b>	54
-------------------	-------------	------------------------	----

BYTE(s)	BITs	TYPE	RANGE	RES.	UNITS	DATA ELEMENT
D1-D2		2b	-3199.9 to +3200.0	0.1	mil	1 - 2 Threshold Angle
D3-D4		2b	-3199.9 to +3200.0	0.1	mil	2 - 1 Threshold Angle
D5-D6		2b	-25.00 to +25.00	0.01	meter	Orientation 1 Vehicle ΔX
D7-D8		2b	-25.00 to +25.00	0.01	meter	Orientation 1 Vehicle ΔY
D9-D10		2b	-25.00 to +25.00	0.01	meter	Orientation 1 Vehicle ΔZ
D11-D12		2b	-25.00 to +25.00	0.01	meter	Orientation 2 PD ΔX
D13-D14		2b	-25.00 to +25.00	0.01	meter	Orientation 2 PD ΔY
D15-D16		2b	-25.00 to +25.00	0.01	meter	Orientation 2 PD ΔZ
D17-D18		2b	2 to 15	0.25	minute	Exclusive ZUPT mode ZUPT interval
D19-D20		ub	2 to 63	1	minute	Odometer Mode ZUPT interval
D21-D22		ub	3.5 to 34.0	0.25	minute	Static Align Time
D23-D24		ub	0 to 10 (0 valid only if D29/5 is reset)	1	second	Shot Detect Interval
D25-D28		dis	n/a	n/a	n/a	Configuration definition flags (See Appendix C)
D29-D30		ub	0.750 to 1.250	0.001	n/a	Odometer Scale Factor
D31-D32		2b	-3276.8 to +3276.7	0.1	μ-radian /km	Fuel Consumption Factor
D33		hex	00 to 3F	n/a	n/a	DRUH Coordinate Frame Code for Orientation 1
D34		hex	00 to 3F	n/a	n/a	DRUH Coordinate Frame Code for Orientation 2
D35-D36		ub	0 thru 15	1	n/a	Current Configuration Code Number
D37-D38		2b	-25.00 to +25.00	0.01	meter	Odometer action point ΔX
D39-D40		2b	-25.00 to +25.00	0.01	meter	Odometer action point ΔY
D41-D42		2b	-25.00 to +25.00	0.01	meter	Odometer action point ΔZ
D43-D44		2b	-25.00 to +25.00	0.01	meter	GPS antenna ΔX
D45-D46		2b	-25.00 to +25.00	0.01	meter	GPS antenna ΔY
D47-D48		2b	-25.00 to +25.00	0.01	meter	GPS antenna ΔZ
D49-D50		ub	10 to 900	1	second	GPS Update Time-out Interval
D51-D52		ub	0 to 256	1	meter	GPS EPE Good Value
D53-D54		ub	0 to 32,535	1	meter	GPS EPE Poor Value

A.3.2.7.16 DATUM DATA message.

Function: Provides datum data for the datum number in the requesting RETURN DATUM DATA command. Update of datums #63 and #64 may require up to two seconds following an ACCEPT USER DATUM command. Datum data elements are defined in Appendix G.

<b>IDENTIFIER</b>	19 (10011b)	<b>DATA BYTE COUNT</b>	40
-------------------	-------------	------------------------	----

BYTE(s)	BITs	TYPE	RANGE	RES.	UNITS	DESCRIPTION
D1		ub	1 to 64	1	n/a	Reference Number for DRUH datum in use
D2		ub	0 to 64	1	n/a	Requested Datum Reference Number
D3-D8		ASCII	Valid Datum ID Code (Appendix G)	n/a	n/a	Datum ID Code
D9-D12		2b	±2000.000	0.001	meters	Datum delta-a
D13-D16		2b	±2000.000	0.001	n/a	Datum delta-f x10E7
D17-D18		2b	±2000.0	0.1	meters	Datum delta-x
D19-D20		2b	±2000.0	0.1	meters	Datum delta-y
D21-D22		2b	±2000.0	0.1	meters	Datum delta-z
D23-D24		ub	0 to 26	1	n/a	MGRS Row Advance
D25-D40		ASCII	See Appendix G	n/a	n/a	Datum Descriptor

A.3.2.7.17 GPS TIME & DAY DATA message.

Function: Passes time and day data provided to the DRUH in GPS message #5040. The time represented is the time of validity of the last time mark message. If GPS message #5040 has never been received or has not been refreshed within two seconds of its previous reception, or if the GPS receiver has failed; GPS Time shall be zero and other data elements may be outside their specified limits.

<b>IDENTIFIER</b>	20 (10100b)	<b>DATA BYTE COUNT</b>	24
-------------------	-------------	------------------------	----

BYTE(s)	BITs	TYPE	RANGE	RES.	UNITS	DATA ELEMENT
D1-D2	*	*	*	*	*	GPS Time (Word 1)
D3-D4	*	*	*	*	*	GPS Time (Word 2)
D5-D6	*	*	*	*	*	GPS Time (Word 3)
D7-D8	*	*	*	*	*	GPS Time (Word 4)
D9-D10	*	*	*	*	*	Time Reference (Word 19)
D11-D12	*	*	*	*	*	Hours (Word 20)
D13-D14	*	*	*	*	*	Minutes (Word 21)
D15-D16	*	*	*	*	*	Seconds (Word 22)
D17-D18	*	*	*	*	*	Day of Week (Word 23)
D19-D20	*	*	*	*	*	Day of Month (Word 24)
D21-D22	*	*	*	*	*	Month (Word 25)
D23-D24	*	*	*	*	*	Year (Word 26)

- \* Shall be as specified in ICD-GPS-153 for the GPS message #5040 (Current Status) data elements and words specified in the DATA ELEMENT column.

A.3.2.7.18 GPS POSITION DATA message.

Function: Passes GPS receiver derived antenna position and status indicators of position accuracy provided to the DRUH in GPS message #5040 (Current Status). If GPS message #5040 has never been received or has not been refreshed within two seconds of its previous reception, or if the GPS receiver has failed; GPS Time shall be set to 0 and other data elements may be outside the specified limits.

<b>IDENTIFIER</b>	21 (10101b)	<b>DATA BYTE COUNT</b>	64
-------------------	-------------	------------------------	----

BYTE(s)	BITS	TYPE	RANGE	RES.	UNITS	DATA ELEMENT
D1-D2	*	*	*	*	*	GPS Time (Word 1)
D3-D4	*	*	*	*	*	GPS Time (Word 2)
D5-D6	*	*	*	*	*	GPS Time (Word 3)
D7-D8	*	*	*	*	*	GPS Time (Word 4)
D9-D10	*	*	*	*	*	Position (Word 5)
D11-D12	*	*	*	*	*	Position (Word 6)
D13-D14	*	*	*	*	*	Position (Word 7)
D15-D16	*	*	*	*	*	Position (Word 8)
D17-D18	*	*	*	*	*	Position (Word 9)
D19-D20	*	*	*	*	*	Position (Word 10)
D21-D22	*	*	*	*	*	Position (Word 11)
D23-D24	*	*	*	*	*	Position (Word 12)
D25-D26	*	*	*	*	*	Position (Word 13)
D27-D28	*	*	*	*	*	Position (Word 14)
D29-D30	*	*	*	*	*	Position (Word 15)
D31-D32	*	*	*	*	*	Position (Word 16)
D33-D34	*	*	*	*	*	Position (Word 17)
D35-D36	*	*	*	*	*	Position (Word 18)
D37-D38	*	*	*	*	*	FOM (Word 35)
D39-D40	*	*	*	*	*	TFOM (Word 36)
D41-D42	*	*	*	*	*	EPE (Word 40)
D43-D44	*	*	*	*	*	EPE (Word 41)
D45-D46	*	*	*	*	*	EPE Units (Word 42)
D47-D48	*	*	*	*	*	Nav Converge (Word 43)
D49-D50	*	*	*	*	*	Elevation Status (Word 44)
D51-D52	*	*	*	*	*	Current DOP (Word 45)
D53-D54	*	*	*	*	*	Current DOP (Word 46)
D55-D56	*	*	*	*	*	Datum Identifier (Word 86)
D57-D58	*	*	*	*	*	Datum Identifier (Word 87)
D59-D60	*	*	*	*	*	Datum Identifier (Word 88)
D61-D62	*	*	*	*	*	SA/A-S Message (Word 78)
D63-D64		ub	0	1	n/a	Spare

- \* Shall be as specified in ICD-GPS-153 for the GPS message #5040 (Current Status) data elements and words specified in the DATA ELEMENT column.

A.3.2.7.19 GPS WARNING message.

Function: Outputs GPS Warning Message, #5044, ASCII character strings output by the GPS receiver and queued by the DRUH. In response to the RETURN GPS WARNING command, the currently queued warning shall be returned. In response to the RETURN NEXT GPS WARNING the currently queued warning shall be deleted and the next saved warning shall become the current warning and be returned. When no GPS Warning Messages are saved, the DRUH shall return: GPS Time = 0; Warning ID = 0; and Warning Message, (W6-W9) = "No PLGR "; (W10-W13) = " "; (W14-W17) = "Warnings"; (W18-W21) = " ".

<b>IDENTIFIER</b>	22 (10110b)	<b>DATA BYTE COUNT</b>	42
-------------------	-------------	------------------------	----

BYTE(s)	BITS	TYPE	RANGE	RES.	UNITS	DATA ELEMENT
D1-D2	*	*	*	*	*	GPS Time (Word 1)
D3-D4	*	*	*	*	*	GPS Time (Word 2)
D5-D6	*	*	*	*	*	GPS Time (Word 3)
D7-D8	*	*	*	*	*	GPS Time (Word 4)
D9-D10	*	*	*	*	*	Warning ID (Word 5)
D11-D12	*	*	*	*	*	Warning Message (Word 6)
D13-D14	*	*	*	*	*	Warning Message (Word 7)
D15-D16	*	*	*	*	*	Warning Message (Word 8)
D17-D18	*	*	*	*	*	Warning Message (Word 9)
D19-D20	*	*	*	*	*	Warning Message (Word 10)
D21-D22	*	*	*	*	*	Warning Message (Word 11)
D23-D24	*	*	*	*	*	Warning Message (Word 12)
D25-D26	*	*	*	*	*	Warning Message (Word 13)
D27-D28	*	*	*	*	*	Warning Message (Word 14)
D29-D30	*	*	*	*	*	Warning Message (Word 15)
D31-D32	*	*	*	*	*	Warning Message (Word 16)
D33-D34	*	*	*	*	*	Warning Message (Word 17)
D35-D36	*	*	*	*	*	Warning Message (Word 18)
D37-D38	*	*	*	*	*	Warning Message (Word 19)
D39-D40	*	*	*	*	*	Warning Message (Word 20)
D41-D42	*	*	*	*	*	Warning Message (Word 21)

- \* Shall be as specified in ICD-GPS-153 for the GPS message #5044 (Warning Messages) data elements and words specified in the DATA ELEMENT column.

A.3.2.7.20 PRECISION NAVIGATION DATA message.

Function: Provides high resolution grid position data.

<b>IDENTIFIER</b>	24 (11000b)	<b>DATA BYTE COUNT</b>	48
-------------------	-------------	------------------------	----

BYTE(s)	BITS	TYPE	RANGE	RES.	UNITS	DATA ELEMENT
D1 bits 5-7	4	dis	0	n/a	n/a	Spare Bits
D1 bit 4	1	dis	0 or 1	n/a	n/a	Relative Offsets Applied output flag
D1 bits 0-3	4	ub	0 to 1	1	n/a	Host (DRUH) Grid 0 = BNG 1 = UTM
D2	7	2b	-60 to +60	1	n/a	DRUH Hemisphere & Zone + = northern hemisphere - = southern hemisphere
D3-D6		ub	0 to 999,999.99 *	0.01	meter	Easting
D7-D10		ub	0 to 10,000,000.00	0.01	meter	Northing
D11-D14		2b	-32,768.00 to +32,767.00	0.01	meter	Altitude
D15-D18	17	ub	0 to 1,310,710 **	10	meter	Distance Traveled ***
D19-D24		ASCII	Valid Datum ID Code (Appendix G)	n/a	n/a	Datum ID Code (6 ASCII Characters)
D25-D28		ub	0 to 6,399.99	0.01	mil	Pointing Device Geodetic Azimuth or Grid Azimuth
D29-D32		2b	-1600.00 to +1600.00	0.01	mil	Pointing Device Pitch
D33-D36		2b	-3199.99 to +3200.00	0.01	mil	Pointing Device Roll or Cant
D37-D40		ub	0 to 6,399.99	0.01	mil	Vehicle Geodetic or Grid Azimuth
D41-D44		2b	-1600.00 to +1600.00	0.01	mil	Vehicle Pitch
D45-D48		2b	-3199.99 to +3200.00	0.01	mil	Vehicle Roll or Cant

\* Actual limits are the UTM zone boundaries plus zone extension, which are latitude and datum dependent.

\*\* If the actual value of the parameter is outside the range, the output value shall be fixed at the appropriate positive or negative range limit.

\*\*\* Total distance traveled since turn-on or last RESET DISTANCE command. Distance Traveled may not accurately reflect the actual vehicle trajectory during Dynamic Align.

A.3.2.7.21 DRUH S/W IDENTIFICATION DATA message.

Function: Provides the ID and revision numbers for the seven CSCIs of the DRUH, the DRUH S/N, and the GPS receiver hardware and software version numbers.

<b>IDENTIFIER</b>	25 (11001b)	<b>DATA BYTE COUNT</b>	64
-------------------	-------------	------------------------	----

BYTES(s)	BITs	TYPE	RANGE	RES.	UNITS	DESCRIPTION
D1-D4		ub	0 to 4,294,967,295	1	N/A	ID Number, DRUH Navigation Processor
D5-D8		ub	0 to 4,294,967,295	1	N/A	ID Number, Sensor Processor
D9-D12		ub	0 to 4,294,967,295	1	N/A	ID Number, DRUH Permanently Stored Configuration Data
D13-D16		ub	0 to 4,294,967,295	1	N/A	ID Number, DRUH Permanently Stored Datum Data
D17-D20		ub	0 to 4,294,967,295	1	N/A	ID Number, Bootstrap Loader
D21-D22		ub	0 to 65,535	1	N/A	Rev. Number, DRUH Nav. Processor
D23-D24		ub	0 to 65,535	1	N/A	Rev. Number, DRUH Sensor Processor
D25-D26		ub	0 to 65,535	1	N/A	Rev. Number, DRUH Config. Data
D27-D28		ub	0 to 65,535	1	N/A	Rev. Number, DRUH Datum Data
D29-D30		ub	0 to 65,535	1	N/A	Rev. Number, Bootstrap Loader
D31-D32		ub	0 to 65,535	1	N/A	DRUH Serial Number (Customer)
D33-D34		ub	0 to 65,535	1	N/A	DRUH Serial Number (Vendor)
D35-D36		2b	-32,768 to + 32,767	1	N/A	GPS receiver S/W Version from GPS message #5040 (Word 48)
D37-D38		2b	-32,768 to + 32,767	1	N/A	GPS receiver H/W Version from GPS message #5040 (Word 49)
D39-D40		ASCII	A-Z, a-z, 0-9, -, space	N/A	N/A	Loader Revision ID (2 ASCII Characters)
D41-D45		ASCII	A-Z, a-z, 0-9, -, space	N/A	N/A	DRUH Software Version ID (5 ASCII Characters)
D46-D56		ASCII	Note 1	N/A	N/A	DRUH Software Build Date (11 ASCII Characters)
D57-D64		ASCII	Note 2	N/A	N/A	DRUH Software Build Time (8 ASCII Characters)

Note 1: 11 ASCII characters shall be formatted as MMM/DD/YYYY, where:

MMM is the month code, for the build month, per Note 3

DD is the build day of the month (range: 01-31)

YYYY is the build year (for example, 1996)

/ is the ASCII / character

Note 2: 8 ASCII characters shall be formatted as hh:mm:ss, where:

hh is the build hour (range: 00 - 23)

mm is the build minute (range: 00 - 59)

ss is the build second (range: 00 - 59)

: is the ASCII : character

Note 3: Month Code/Month

JAN	January
FEB	February
MAR	March
APR	April
MAY	May
JUN	June
JUL	July
AUG	August
SEP	September
OCT	October
NOV	November
DEC	December

This Page Intentionally Left Blank.

## APPENDIX B

## STATUS, ALERT, AND BIT DATA

## B.1. SCOPE

B.1.1 Scope. This appendix provides the requirements for DRUH use of STATUS DATA, ALERT DATA, and BIT DATA. This appendix is a mandatory part of this specification. The information herein is intended for compliance.

## B.2. APPLICABLE DOCUMENTS

(This section is not applicable to this appendix.)

## B.3. REQUIREMENTS

B.3.1 STATUS DATA. The DRUH shall report STATUS DATA in every DRUH/host RS-422 interface response message and in the DRUH/host 1553 interface ATTITUDE DATA BLOCK, GRID POSITION DATA BLOCK, and GEODETIC POSITION DATA BLOCK messages. STATUS DATA indications, word/byte and bit positions, and set and reset conditions shall be as specified in Table B-I. Additional requirements for setting and resetting STATUS DATA bits are specified throughout this document.

B.3.1.1 Status states and initialization. At turn-on, all STATUS DATA bits shall be reset (= 0) unless otherwise indicated in Table B-1. A STATUS DATA bit shall be set (= 1) when a condition specified in the SET CONDITION column of Table B-I occurs. A set STATUS DATA bit shall be reset (= 0) when a condition specified in the RESET CONDITION column of Table B-I occurs. Unless otherwise indicated in Table B-I, STATUS DATA bits shall retain their current state upon acceptance of a RESTART command.

B.3.1.2 Alert status reporting. STATUS DATA S2/1 (DRUH Alert) and S5/3 (Change In ALERT DATA) shall be reported separately for each data bus.

STATUS DATA S2/1 (DRUH Alert), for a data bus, shall be set whenever any ALERT DATA bit, applicable to that bus, is set and shall be reset whenever all ALERT DATA bits, applicable to that bus, are reset.

For a RS-422 data bus, STATUS DATA S5/3 (Change In ALERT DATA) shall be set when any ALERT DATA bit, applicable to that bus, changes state. When a RETURN ALERT DATA command is received on a RS-422 data bus, STATUS DATA S5/3, only for that bus, shall be reset prior to sending the response ALERT DATA message. STATUS

DATA S5/3 shall always be in the reset state for the MIL-STD-1553 data bus.

B.3.1.3 Change in BIT status reporting. STATUS DATA S5/2 (Change In BIT DATA) shall be reported separately for each data bus. For a RS-422 data bus, STATUS DATA S5/2 shall be set when any BIT DATA bit changes state. When a RETURN BUILT-IN-TEST DATA command is received on a RS-422 data bus, STATUS DATA S5/2, only for that bus, shall be reset prior to sending the response BUILT-IN-TEST DATA message. STATUS DATA S5/2 shall always be in the reset state for the MIL-STD-1553 data bus.

B.3.2 ALERT DATA. The DRUH shall report ALERT DATA in the DRUH/host RS-422 interface ALERT DATA message and in the DRUH/host 1553 interface ATTITUDE DATA BLOCK, GRID POSITION DATA BLOCK, and GEODETIC POSITION DATA BLOCK messages. ALERT DATA indications, word/byte and bit positions, data bus requirements, and set and reset conditions shall be as specified in Table B-II. Additional requirements for setting and resetting ALERT DATA bits are specified throughout this document.

ALERT DATA shall be reported separately for each data bus. Bus applicability requirements are given in the BUS(ES) SET ON column of Table B-II.

B.3.2.1 Alert states. At initialization, the default (initial) state for all ALERT DATA bits shall be reset (= 0). An ALERT DATA bit shall be set (= 1) when a condition specified in the ALERT SET CONDITION column of Table B-II occurs. A set ALERT DATA bit shall be reset (= 0) when a condition specified in the ALERT RESET CONDITION column of Table B-II occurs.

B.3.2.2 OVERRIDE ALERT command. Upon receipt of an OVERRIDE ALERT command, the DRUH shall reset all overrideable ALERT DATA bits which were transmitted in the last ALERT DATA message. ALERT DATA bits set after the last ALERT DATA message shall not be reset. Non-overrideable ALERT DATA bits shall not be reset until the appropriate reset action has occurred. Overrideable ALERT DATA bits are indicated by "OVERRIDE ALERT command" in the ALERT RESET CONDITION column of Table B-II. All other ALERT DATA bits are non-overrideable.

B.3.3 STATUS DATA and ALERT DATA timing.

- a. A change in the following STATUS DATA bits, triggered by receipt of a command, shall be available for output within 200 msec of command receipt and shall be reported in the command response message, if the command was received on a Host RS-422 bus:

- S1/6 (DRUH Startup Complete)
- S1/5 (DRUH In Align)
- S1/1 (Position Update Request)
- S1/0 (Auxiliary Bus Control Inhibited)
- S2/6 (Datum or Position Update In Progress)
- S2/4 (Pointing Device In Travel Lock)
- S2/2 (DRUH In Stored Heading Align)
- S3/7 (Orientation Transition In Process)
- S3/4 (ZUPTs Inhibited)
- S4/1 (DRUH In Air Transport)
- S4/0 (DRUH In Marine Transport)
- S5/4 (DRUH In Dynamic Align)
- S5/1 (Host Status A)
- S5/0 (Host Status B)
- S6/5 (GPS Warning Present)

b. The ALERT DATA bit(s) and STATUS DATA S2/1 (DRUH Alert) and S5/3 (Change in ALERT DATA) shall be set within 1 second after receipt of a command that triggers any of the following ALERT DATA bits:

- D2/2 (Position Update Interrupt)
- D2/0 (Shutdown Interrupt)
- D3/7 (Motion During Shutdown Request)
- D3/6 (Motion During Restart Request)
- D3/5 (Motion During Update Request)
- D4/7 (DRUH Datum Change)
- D4/6 (DRUH Hemisphere/Zone Change)
- D4/4 (Altitude Update Rejected)
- D4/3 (Horizontal Position Update Rejected)
- D4/2 (GPS Position and Update Disagree)
- D4/1 (Altitude Update Excessive)
- D4/0 (Horizontal Position Update Excessive)

For deferred commands, the above requirement shall apply within 1 second of end of the deferring condition.

c. For a command, received on a Host RS-422 bus, which triggers any of the following ALERT DATA bits, the ALERT DATA bit(s) shall be set before the command response message is sent and STATUS DATA S2/1 (DRUH Alert) and S5/3 (Change in ALERT DATA) shall be set in the command response message:

- D5/7 (Invalid Update Request)
- D5/6 (Invalid Mode Request)
- D5/5 (Invalid Data Request)
- D5/2 (Invalid Data Received)
- D5/1 (Invalid Command Received)
- D5/0 (Undefined Command Received)

If the triggering command was received on a MIL-STD-1553 bus, the ALERT DATA bit(s) and S2/1 shall be set within 200 msec of receiving the command.

B.3.4 BIT DATA. The DRUH shall report BIT DATA in the DRUH/host RS-422 interface BUILT-IN-TEST-DATA message and in the DRUH/host 1553 interface ATTITUDE DATA BLOCK, GRID POSITION DATA BLOCK, and GEODETIC POSITION DATA BLOCK messages. BIT DATA indications, word/byte and bit positions, and set and reset conditions shall be as specified in Table B-III. Additional requirements for setting and resetting BIT DATA bits are specified throughout this specification.

B.3.4.1 BIT states. At initialization, the default state for all BIT DATA bits shall be reset (= 0). A BIT DATA bit shall be set (= 1) when a condition specified in the SET CONDITION column of Table B-III occurs. A set BIT DATA bit shall be reset (= 0) when a condition specified in the RESET CONDITION column of Table B-III occurs.

TABLE B-I. Status.

1553 WORD /BIT	RS-422 BYTE /BIT	STATUS NAME	SET CONDITION	RESET CONDITION
W1/00	S1/7	DRUH In Startup	Turn-on.	DRUH operations are sufficient for proceeding with alignment.
W1/01	S1/6	DRUH Startup Complete	DRUH operations are sufficient for proceeding with alignment.	A RESTART command is accepted.
W1/02	S1/5	DRUH In Align	DRUH is in Accelerated, Static or Dynamic Align.	DRUH completes Accelerated, Static or Dynamic Align; or DRUH in Restart Required state; or a RESTART command is accepted. Shall reset within 8 seconds of Align Time To Go becoming zero.
W1/03	S1/4	OK To Move	In Static or Dynamic Align, when alignment accuracy can support Interrupted Static Align positioning accuracy (the host system can be moved); or upon successful Accelerated Align completion.	DRUH in Restart Required state; or a RESTART command is accepted.
W1/04	S1/3	VMS Inhibited	VMS aiding is inhibited.	VMS aiding is enabled; or RESTART command accepted.
W1/05	S1/2	ZUPT Stop Request	DRUH determines it needs a ZUPT. Shall not transition to set while S3/2 (DRUH In Motion) = 0.	Requested ZUPT completed; or useable GPS data available; or RESTART command accepted.
W1/06	S1/1	Position Update Request	Position not initialized after an abnormal shutdown; or position initialized from GPS with EPE > good value; or time since last completed ZUPT or last usable GPS data > 150 percent of the applicable ZUPT interval; or time since last ZUPT in Interrupted Static Align > 6 minutes.	Host position update or GPS position update accepted; or in Dynamic Align.
W1/07	S1/0	Auxiliary Bus Control Inhibited	INHIBIT AUXILIARY BUS CONTROL command accepted.	ENABLE AUXILIARY BUS CONTROL command accepted; or inactivity on Main RS-422 Bus for two seconds.

TABLE B-I. Status. (Continued)

1553 WORD/ BIT	RS-422 BYTE/ BIT	STATUS NAME	SET CONDITION	RESET CONDITION
W1/08	S2/7	ZUPT In Progress	ZUPT initiation.	Completion or interruption of a ZUPT; or RESTART command accepted.
W1/09	S2/6	Datum or Position Update In Progress	Receipt of a position or datum update from the host.	Completion or termination of a position or datum update.
W1/10	S2/5	BIT Malfunction Detected	Any BIT DATA bit is set.	All BIT DATA bits are reset.
W1/11	S2/4	Pointing Device in Travel Lock	Host signals pointing device is in travel lock. [Default state at turn-on if: CFG D29/4 (Travel Lock Commands) is set; or CFG D29/4 and D29/3 (Travel Lock Discrete) are both reset.]	Host signals pointing device is out of travel lock.
W1/12	S2/3	Shot Detect	DRUH detects a gun shot.	Completion of Shot Detect Interval delay; or RESTART command accepted. Shall always be reset if CFG D29/5 (Shot Detect) is reset.
W1/13	S2/2	DRUH In Stored Heading Align	DRUH is in Accelerated Align.	DRUH is not in Accelerated Align; or a RESTART command is accepted. Shall be reset within 8 seconds of Align Time To Go becoming zero.
W1/14	S2/1	DRUH Alert	Any ALERT DATA bit is set. (Data bus dependent)	All ALERT DATA bits are reset. (Data bus dependent)
W1/15	S2/0	Relative Offsets Determined	At initialization CFG D28/3 (Reset Relative Offsets) is reset and the previously stored state of S2/0 was true; or the DRUH determines relative offsets during a position update.	At initialization CFG D28/3 (Reset Relative Offsets) is set or a RESET RELATIVE OFFSETS command is received; or the datum is changed without new offsets being determined.

TABLE B-I. Status. (Continued)

1553 WORD/ BIT	RS-422 BYTE/ BIT	STATUS NAME	SET CONDITION	RESET CONDITION
W2/0	S3/7	Orientation Transition in Process	STATUS DATA S3/1 & S4/7 may be invalid and orientation/attitude accuracy may be degraded because the Orientation (1 or 2) or boresight angles are in the process of being changed.	Orientation (1 or 2) or boresight angle changes are completed; or a RESTART command is accepted.
W2/1	S3/6	VMS Damping in Process	DRUH starts VMS aiding.	DRUH stops VMS aiding; or a RESTART command is accepted.
W2/2	S3/5	VMS Calibration Completed	Accurate DRUH-to-Host alignment and VMS scale factor determined.	DRUH-to-Host alignment and VMS scale factor inadequate to maintain VMS aided accuracy requirements; or a RESTART command is accepted.
W2/3	S3/4	ZUPTs Inhibited	INHIBIT ZERO-VELOCITY UPDATES command accepted; or ZUPTs inhibited in Air or Marine Transport.	ENABLE ZERO-VELOCITY UPDATES, or RESTART, or TRANSPORT MODE COMPLETE command accepted.
W2/4	S3/3	DRUH Zone Extension Enabled	DRUH is operating in Extended Zone mode.	DRUH is operating in Normal Zone mode.
W2/5	S3/2	DRUH In Motion	Linear motion, in excess of nominal stationary conditions, is detected by the DRUH.	Linear motion is within the nominal stationary conditions; or a RESTART command is accepted.
W2/6	S3/1	Orientation Attitude Data Valid	In Static or Dynamic Align, when the DRUH estimated azimuth error $\leq 1.0$ mil PE; or upon successful completion of Accelerated Align.	A RESTART command is accepted.
W2/7	S3/0	Inertial Altitude Fixed	When altitude is fixed in Air or Marine Transport.	When altitude is not fixed; or a RESTART command is accepted.

TABLE B-I. Status. (Continued)

1553 WORD/ BIT	RS-422 BYTE/ BIT	STATUS NAME	SET CONDITION	RESET CONDITION
W2/08	S4/7	DRUH In Orientation 2	DRUH in Orientation 2.	DRUH in Orientation 1.
W2/09	S4/6	1553 Bus Active	Activity is present on the 1553 data bus.	There was no 1553 data bus activity for two seconds; or a RESTART command is accepted.
W2/10	S4/5	RS-422 Bus Active	Activity is present on the host RS-422 data bus.	There was no host RS-422 data bus activity for two seconds; or a RESTART command is accepted.
W2/11	S4/4	DRUH Shutdown Complete	The DRUH has completed shutdown processing and is ready to have power removed.	The DRUH has not completed shutdown processing and is not ready to have power removed.
W2/12	S4/3	Supplier Reserved	Supplier Specified.	Supplier Specified.
W2/13	S4/2	Supplier Reserved	Supplier Specified.	Supplier Specified.
W2/14	S4/1	DRUH In Air Transport	AIR TRANSPORT MODE REQUEST command accepted.	A TRANSPORT MODE COMPLETE or RESTART command is accepted.
W2/15	S4/0	DRUH In Marine Transport	MARINE TRANSPORT MODE REQUEST command accepted.	A TRANSPORT MODE COMPLETE or RESTART command is accepted.

TABLE B-I. Status. (Continued)

1553 WORD/ BIT	RS-422 BYTE/ BIT	STATUS NAME	SET CONDITION	RESET CONDITION
W3/0	S5/7	GPS Damping in Process	A usable GPS data set is available to aid the DRUH.	Time since the last accepted GPS update exceeds the GPS Update Time-out Interval (configuration data); or GPS aiding is inhibited; or a RESTART command is accepted.
W3/1	S5/6	GPS Enabled	[CONFIG D27/7 (GPS Installed) is set at initialization, or an ENABLE INTEGRATED MODE command is accepted] and BIT DATA D2/2 (GPS Fail) is reset.	CONFIG D27/7 (GPS Installed) is reset; or an ENABLE INERTIAL MODE or RESTART command is accepted; or BIT DATA D2/2 (GPS Fail) is set.
W3/2	S5/5	Y-code SVs Selected	The GPS receiver was last setup to select Y-code satellites only.	The GPS receiver was last setup to select P or Y code satellites.
W3/3	S5/4	DRUH In Dynamic Align	DRUH is in Dynamic Align.	DRUH is not in Dynamic Align; or a RESTART command is accepted. Shall be reset within 8 seconds of Align Time To Go becoming zero.
W3/4	S5/3	Change In ALERT DATA	An ALERT DATA bit has changed state since the last ALERT DATA message. (Data bus dependent)	Transmission of an ALERT DATA message; or a RESTART command is accepted. (Data bus dependent)
W3/5	S5/2	Change in BIT DATA	A BIT DATA bit has changed state since the last BIT DATA message. (Data bus dependent)	Transmission of a BIT DATA message; or a RESTART command is accepted. (Data bus dependent)
W3/6	S5/1	Host Status A	An ACCEPT HOST STATUS command was accepted with Host Status A set.	An ACCEPT HOST STATUS command was accepted with Host Status A reset.
W3/7	S5/0	Host Status B	An ACCEPT HOST STATUS command was accepted with Host Status B set.	An ACCEPT HOST STATUS command was accepted with Host Status B reset.

TABLE B-I. Status. (Continued)

1553 WORD/ BIT	RS-422 BYTE/ BIT	STATUS NAME	SET CONDITION	RESET CONDITION
W3/08	S6/7	Low GPS S/N Ratio	GPS data indicates $C/N_0 < 35$ dB/Hz on all 4 solution channels.	CFIG D27/7 (GPS Installed) = 0; or BIT DATA D2/3 (GPS Commo Fail) = 1; or GPS data indicates $C/N_0 \geq 35$ dB/Hz on at least one channel; or a RESTART command is accepted; or GPS data not received for $\geq 2$ seconds.
W3/09	S6/6	Degraded GPS Enabled	A USE DEGRADED GPS DATA command is accepted.	DRUH accepts a GPS update with EPE GPS Good Level; or an INERTIAL MODE or RESTART command is accepted.
W3/10	S6/5	GPS Warning Present	DRUH receives and queues a warning from GPS message #5044 (Warning Messages).	RETURN NEXT GPS WARNING or CUE NEXT GPS WARNING commands have deleted the last queued warning.
W3/11	S6/4	1553 Address Parity Fail	The 1553 R/T Address Parity is in error.	The 1553 R/T Address Parity is correct; or a RESTART command is accepted.
W3/12 & 13	S6/3 & 2	GPS Tracking	Indicates number of GPS SVs currently tracked in state 3, 4 or 5 by receiver channels 1-4: 11 signifies = 4 SVs, 10 signifies = 3 SVs, 01 signifies = 1 or 2 SVs, 00 signifies = no SVs	Set = 00 if: CFIG D27/7 (GPS Installed) = 0; or BIT DATA D2/3 (GPS Commo Fail) = 1; or a RESTART command is accepted; or GPS data not received for $\geq 2$ seconds.
W3/14	S6/1	$EPE \leq$ GPS Good Level	Valid GPS data received with $EPE \leq$ GPS Good Level (configuration data); and CFIG D27/7 (GPS Installed) = 1; and BIT DATA D2/3 (GPS Commo Fail) = 0.	GPS data received with $EPE >$ GPS Good Level; or invalid GPS data received; or CFIG D27/7 (GPS Installed) = 0; or BIT DATA D2/3 (GPS Commo Fail) = 1; or a RESTART command is accepted; or GPS data not received for $\geq 2$ seconds.
W3/15	S6/0	$EPE \leq$ GPS Poor Level	Valid GPS data received with $EPE \leq$ GPS Poor Level (configuration data); and CFIG D27/7 (GPS Installed) = 1; and BIT DATA D2/3 (GPS Commo Fail) = 0.	GPS data received with $EPE >$ GPS Poor Level; or invalid GPS data received; or CFIG D27/7 (GPS Installed) = 0; or BIT DATA D2/3 (GPS Commo Fail) = 1; or a RESTART command is accepted; or GPS data not received for $\geq 2$ seconds.

TABLE B-II. Alerts.

1553 WORD/ BIT	RS-422 BYTE/ BIT	ALERT NAME	ALERT SET CONDITION	BUS(ES) SET ON	ALERT RESET CONDITION
W4/00	D1/7	Datum Not Initialized	The DRUH datum has not been initialized.	All data buses.	Completion of update with valid datum from accepted ACCEPT POSITION or ACCEPT GEODETIC DATA command.
W4/01	D1/6	Datums Do Not Agree	The datums used by the DRUH and GPS receiver do not match. (Datums match when: pre-programmed datum IDs are the same; or user datum shift parameters are the same.)	All data buses.	CFIG D27/7 (GPS Installed) = 0; or BIT DATA D2/3 (GPS Commo Fail) = 1; or the datums used by the DRUH and GPS receiver match.
W4/02	D1/5	Datum Update Rejected	A requested datum ID is invalid or an ACCEPT USER DATUM command data element parameter is outside it's allowable range.	Data bus which sent the ACCEPT POSITION, ACCEPT GEODETIC DATA or ACCEPT USER DATUM command.	OVERRIDE ALERT command.
W4/03	D1/4	GPS Unkeyed	GPS message #5040 (Current Status) indicates the GPS receiver is not keyed.	All data buses.	CFIG D27/7 (GPS Installed) = 0; or BIT DATA D2/3 (GPS Commo Fail) = 1; or GPS message #5040 (Current Status) indicates GPS is keyed.
W4/04	D1/3	Update Rejected GPS Invalid	Rejection of position update, with Determine Relative Offsets flag = 1, because current GPS data wasn't usable.	Data bus which sent the ACCEPT POSITION or ACCEPT GEODETIC DATA command.	OVERRIDE ALERT command.
W4/05	D1/2	DRUH Over Temperature	DRUH temperature is too high.	All data buses.	DRUH temperature is not too high.
W4/06	D1/1	DRUH Auto. Temperature Compensation In Process	DRUH is performing its automatic temperature compensation process.	All data buses.	Temperature compensation action is completed.
W4/07	D1/0	Previous Shutdown Abnormal	The DRUH last turned off while: STATUS DATA S3/2 (DRUH in Motion) is set; or shutdown processing wasn't complete; or Align wasn't completed; or ALERT DATA D2/4 (Unable to Complete Align) or D2/3 (Align Interrupt) or D3/1 (Excessive rates) was set.	All data buses.	ACCEPT POSITION or ACCEPT GEODETIC DATA command, or GPS Position Update is accepted.

TABLE B-II. Alerts. (continued)

1553 WORD/ BIT	RS-422 WORD/ BIT	ALERT NAME	ALERT SET CONDITION	BUS(ES) SET ON	ALERT RESET CONDITION
W4/08	D2/7	Vehicle Boresight Angles Not Present	Vehicle Boresight Angles are not initialized.	All data buses.	ACCEPT VEHICLE BORESIGHT Command is accepted.
W4/09	D2/6	Align Initial Position Parameters Not Received	Position has not been initialized by the host or GPS receiver; or Accelerated Align is terminated before successful completion.	All data buses.	In Accelerated Align; or ACCEPT POSITION or ACCEPT GEODETIC DATA command, or GPS Position Update is accepted; or Static Align completed with stored position.
W4/10	D2/5	Stored Heading/Attitude No Good	The saved heading/attitude data are not adequate to accurately complete Accelerated align; or Accelerated Align is terminated for motion.	All data buses.	OVERRIDE ALERT command.
W4/11	D2/4	Unable to Complete Align	Align can't be completed to the required accuracy within the allotted time.	All data buses.	RESTART command is accepted.
W4/12	D2/3	Align Interrupt	[STATUS DATA S3/2 (DRUH in Motion) is set during Accelerated Align or the first 3.5 minutes (maximum) of Static Align, and GPS aiding is inhibited] or [a GPS failure is detected during Dynamic Align and S3/2 (DRUH in Motion) is set and S1/4 (OK to Move) is reset].	All data buses.	RESTART command is accepted.
W4/13	D2/2	Position Update Interrupt	STATUS DATA S3/2 (DRUH in Motion) is set while a position update is processed and the update is rejected.	Data bus which sent the ACCEPT POSITION or ACCEPT GEODETIC DATA command.	ACCEPT POSITION or ACCEPT GEODETIC DATA command is accepted; or after 60 seconds, if S1/1 (Position Update Request) is reset.
W4/14	D2/1	ZUPT Interrupt	STATUS DATA S3/2 (DRUH in Motion) transitions to set while S1/2 (ZUPT Stop Request) is set.	All data buses.	Completion of a ZUPT.
W4/15	D2/0	Shutdown Interrupt	STATUS DATA S3/2 (DRUH in Motion) is set while a STORED HEADING SHUTDOWN command is being processed and the shutdown is rejected.	All data buses.	OVERRIDE ALERT command.

TABLE B-II. Alerts. (continued)

1553 WORD/ BIT	RS-422 BYTE/ BIT	ALERT NAME	ALERT SET CONDITION	BUS(ES) SET ON	ALERT RESET CONDITION
W5/00	D3/7	Motion During Shutdown Request	STATUS DATA S3/2 (DRUH in Motion) is set when a SHUTDOWN or STORED HEADING SHUTDOWN command is received.	Data bus which sent the command.	OVERRIDE ALERT command.
W5/01	D3/6	Motion During Restart Request	RESTART command was rejected because the DRUH was moving.	Data bus which sent the command.	OVERRIDE ALERT command.
W5/02	D3/5	Motion During Update Request	STATUS DATA S3/2 (DRUH in Motion) is set when an update command is received.	Data bus which sent the command.	OVERRIDE ALERT command.
W5/03	D3/4	Insufficient Align Time	A STORED HEADING SHUTDOWN command was rejected because Static align or 15 minutes (maximum) stationary time wasn't completed.	All data buses.	OVERRIDE ALERT command.
W5/04	D3/3	Position Update Beyond Range of Zone Extension	The grid position in an ACCEPT POSITION command is outside the extended boundaries of the designated zone.	Data bus which sent the command.	OVERRIDE ALERT command.
W5/05	D3/2	Verify Input Coordinates	The coordinates in an ACCEPT POSITION or ACCEPT GEODETIC DATA command are more than 2500 meters from the current DRUH position.	Data bus which sent the command.	OVERRIDE ALERT command.
W5/06	D3/1	Excessive Rates	DRUH linear or angular rate capability was exceeded and survey data may be erroneous.	All data buses.	RESTART command is accepted.
W5/07	D3/0	Motion with Pointing Device Out of Travel Lock	STATUS DATA S3/2 (DRUH in Motion) transitions to set while S2/4 (Pointing Device in Travel Lock) is reset.	All data buses.	OVERRIDE ALERT command.

TABLE B-II. Alerts. (continued)

1553 WORD/ BIT	RS-422 BYTE/ BIT	ALERT NAME	ALERT SET CONDITION	BUS(ES) SET ON	ALERT RESET CONDITION
W5/08	D4/7	DRUH Datum Change	The datum in use was changed via a host position update.	Data bus which sent the ACCEPT POSITION or ACCEPT GEODETIC DATA command.	OVERRIDE ALERT command.
W5/09	D4/6	DRUH Hemisphere/ Zone Change	The DRUH hemisphere or UTM zone was changed via a host position update.	Data bus which sent the ACCEPT POSITION or ACCEPT GEODETIC DATA command.	OVERRIDE ALERT command.
W5/10	D4/5	Spare		All data buses.	Always reset.
W5/11	D4/4	Altitude Update Rejected	A host position update was rejected because the altitude closure error exceeded the "reject" criteria.	Data bus which sent the ACCEPT POSITION or ACCEPT GEODETIC DATA command.	OVERRIDE ALERT command.
W5/12	D4/3	Horizontal Position Update Rejected	A host position update was rejected because the horizontal position closure error exceeded the "reject" criteria.	Data bus which sent the ACCEPT POSITION or ACCEPT GEODETIC DATA command.	OVERRIDE ALERT command.
W5/13	D4/2	GPS Position and Update Disagree	A host position update was rejected because the difference between GPS and update positions exceeded the acceptance criteria.	Data bus which sent the ACCEPT POSITION or ACCEPT GEODETIC DATA command.	OVERRIDE ALERT command.
W5/14	D4/1	Altitude Update Excessive	A position update was rejected because the altitude closure error exceeded the "excessive" criteria.	Data bus which sent the ACCEPT POSITION or ACCEPT GEODETIC DATA command.	OVERRIDE ALERT command.
W5/15	D4/0	Horizontal Position Update Excessive	A position update was rejected because the horizontal position closure error exceeded the "reject" criteria.	Data bus which sent the ACCEPT POSITION or ACCEPT GEODETIC DATA command.	OVERRIDE ALERT command.

TABLE B-II. Alerts. (continued)

1553 WORD/ BIT	RS-422 BYTE/ BIT	ALERT NAME	ALERT SET CONDITION	BUS(ES) SET ON	ALERT RESET CONDITION
W6/00	D5/7	Invalid Update Request	A data update request was rejected because the DRUH can not currently accept it.	Data bus which made the request.	OVERRIDE ALERT command.
W6/01	D5/6	Invalid Mode Request	A mode change request was rejected because the DRUH can not currently accept it.	Data bus which made the request.	OVERRIDE ALERT command.
W6/02	D5/5	Invalid Data Request	A RETURN SURVEY QUALITY command was rejected while in Air or Marine Transport.	Data bus which made the request.	OVERRIDE ALERT command.
W6/03	D5/4	Pointing Device Boresight Angles Not Present	Pointing Device Boresight Angles are not initialized.	All data buses.	ACCEPT POINTING DEVICE BORESIGHT command is accepted.
W6/04	D5/3	Configuration Data Not Present	Configuration Data are not initialized.	All data buses.	ACCEPT CONFIGURATION DATA command is accepted.
W6/05	D5/2	Invalid Data Received	A data update command was rejected because a data element was outside the allowable range.	Data bus that sent the invalid data.	OVERRIDE ALERT command.
W6/06	D5/1	Invalid Command Received	An invalid or inhibited command was received on the auxiliary RS-422 data bus.	The auxiliary RS-422 data bus.	OVERRIDE ALERT command.
W6/07	D5/0	Undefined Command Received	An unrecognized command was received.	Data bus which sent the undefined command.	OVERRIDE ALERT command.

TABLE B-II. Alerts. (continued)

1553 WORD/ BIT	RS-422 BYTE/ BIT	ALERT NAME	ALERT SET CONDITION	BUS(ES) SET ON	ALERT RESET CONDITION
W6/08	D6/7	Supplier Reserved	Supplier Specified.	Supplier Specified.	OVERRIDE ALERT command.
W6/09	D6/6	Supplier Reserved	Supplier Specified.	Supplier Specified.	OVERRIDE ALERT command.
W6/10	D6/5	Supplier Reserved	Supplier Specified.	Supplier Specified.	OVERRIDE ALERT command.
W6/11	D6/4	Supplier Reserved	Supplier Specified.	Supplier Specified.	OVERRIDE ALERT command.
W6/12	D6/3	Boundary Crossed	The DRUH has crossed the equator, or normal or extended UTM zone boundary.	All data buses.	OVERRIDE ALERT command.
W6/13	D6/2	DRUH Using Previous VMS Calibration	Having been unable to establish the current DRUH to host alignment and VMS scale factor, the DRUH is using the values from the last successful VMS calibration on the current host.	All data buses.	OVERRIDE ALERT command. *
W6/14	D6/1	VMS Calibration Failed	The DRUH was unable to establish the current DRUH to host alignment and VMS scale factor within the Exclusive ZUPT Mode Interval (configuration data).	All data buses.	OVERRIDE ALERT command. *
W6/15	D6/0	VMS Data Unusable	VMS aiding has been discontinued for the current mission leg because VMS data are unacceptable for aiding.	All data buses.	Completion of a ZUPT.

\* When overridden, this alert may immediately set again if the condition which caused the alert has not changed.

NOTE: Integrators should not implement checking of "spare" or "supplier reserved" ALERT DATA bits. They are subject to future change.

TABLE B-III. BIT data.

1553 WORD/ BIT	RS-422 BYTE/ BIT	FAULT NAME	SET CONDITION	RESET CONDITION
W7/00	D1/7	DRUH Fail	DRUH fault(s) present. Once set, shall remain set until shutdown.	No DRUH faults present.
W7/01	D1/6	DRUH Inertial Fail	DRUH sensor related fault(s) present.	No DRUH sensor related faults present.
W7/02	D1/5	DRUH Non-Inertial Fail	DRUH non-sensor related fault(s) present.	No DRUH non-sensor related faults present.
W7/03	D1/4	spare		Always reset.
W7/04	D1/3	spare		Always reset.
W7/05	D1/2	spare		Always reset.
W7/06	D1/1	spare		Always reset.
W7/07	D1/0	spare		Always reset.
W7/08	D2/7	spare		Always reset.
W7/09	D2/6	spare		Always reset.
W7/10	D2/5	spare		Always reset.
W7/11	D2/4	GPS Antenna Fault	CFIG D27/7 (GPS Installed) = 1, and GPS communications OK, and Antenna source in GPS message #5040 (Current Status) ≠ CFIG D27/3 (Integral/External Antenna).	CFIG D27/7 (GPS Installed) = 0, or GPS communications failed, or Antenna source in GPS message #5040 (Current Status) = CFIG D27/3 (Integral/External Antenna).
W7/12	D2/3	GPS Communication Fail	CFIG D27/7 (GPS Installed) = 1, and DRUH and GPS receiver are not properly communicating serial data and/or 1 PPS time mark pulses.	CFIG D27/7 (GPS Installed) = 0, or DRUH and GPS receiver are properly communicating serial data and 1 PPS time mark pulses.
W7/13	D2/2	GPS Fail	CFIG D27/7 (GPS Installed) = 1, and GPS communications OK, and RPU fail indicated in GPS message #3 (Time Mark).	CFIG D27/7 (GPS Installed) = 0, or GPS communications failed, or RPU fail not indicated in GPS message #3 (Time Mark) and a RESTART or ENABLE INTEGRATED MODE command has been accepted.
W7/14	D2/1	VMS Fail	CFIG D29/0 (Odometer Installed) = 1, and a VMS fault was detected.	CFIG D29/0 (Odometer Installed) = 0, or No VMS faults detected.
W7/15	D2/0	VMS Drive Fail	CFIG D29/0 (Odometer Installed) = 1, and a VMS fault was detected, and [VMS hardware BIT passed or VMS hardware BIT not performed].	CFIG D29/0 (Odometer Installed) = 0, or no VMS faults detected, or VMS hardware BIT failed.

NOTE: Integrators should not implement checking of "spare" BIT DATA bits. They are subject to future change.

This Page Intentionally Left Blank.

## APPENDIX C

## CONFIGURATION DATA

## C.1. SCOPE

C.1.1 Scope. This appendix contains requirements for using configuration data to tailor DRUH functionality to specific hosts. This appendix is a mandatory part of this specification. The information herein is intended for compliance.

## C.2. APPLICABLE DOCUMENTS

(This section is not applicable to this appendix.)

## C.3. REQUIREMENTS

C.3.1 Configuration data. The DRUH shall use configuration data to tailor its operation to host requirements. The DRUH shall contain 15 sets of fixed configuration data and shall accept changeable configuration data via the data buses. Unless otherwise specified, the requirements associated with configuration data apply whether the data are fixed or were entered via ACCEPT CONFIGURATION DATA, ACCEPT VEHICLE BORESIGHT, or ACCEPT POINTING DEVICE BORESIGHT commands.

C.3.2 Initializing configuration data. Upon activation, the DRUH shall: determine the configuration code number from the configuration discrettes on J1; and use the corresponding configuration data. For configuration codes 0 - 14, the DRUH shall use the corresponding permanently stored configuration data set. For configuration code 15, the DRUH shall use configuration data loaded via an ACCEPT CONFIGURATION DATA command.

For configuration code 15, if configuration data are invalid, the DRUH shall: Set ALERT DATA D5/3 (Configuration Data Not Present); set STATUS DATA S1/7 (DRUH In Startup); reset STATUS DATA S1/4 (OK to Move), S1/5 (DRUH In Align), S2/2 (DRUH In Stored Heading Align) and S5/4 (DRUH In Dynamic Align); and remain in initialization.

For configuration codes 0 - 14, the DRUH shall set BIT DATA D1/7 (DRUH Fail) if configuration data are invalid.

C.3.2.1 ACCEPT CONFIGURATION DATA command response. For configuration code 15, when an ACCEPT CONFIGURATION DATA command is received, the DRUH:

- a. Shall accept the command if all data elements are within their allowable ranges and STATUS DATA S3/2 (DRUH in Motion) is reset.
- b. Shall reject the command and set ALERT DATA D5/2 (Invalid Data Received) if any data element is outside the allowable range.
- c. May reject the command and set ALERT DATA D3/5 (Motion During Update Request) if STATUS DATA S3/2 (DRUH in Motion) is set.

For configuration codes 0 - 14, the DRUH shall reject the command and set ALERT DATA D5/7 (Invalid Update Request) when an ACCEPT CONFIGURATION DATA command is received.

When an ACCEPT CONFIGURATION DATA command is accepted, the DRUH:

- a. Shall retain and use the new configuration data until changed or rendered invalid.
- b. May set STATUS DATA S1/1 (Position Update Request).
- c. Shall set ALERT DATA D5/4 (Pointing Device Boresight Angles Not Present) if the Pointing Device Boresight Angles flag (CFIG D29/7) is set.
- d. Shall set ALERT DATA D2/7 (Vehicle Boresight Angles Not Present) if the Vehicle Boresight Angles flag (CFIG D29/6) is set.
- e. Shall reset ALERT DATA D5/3 (Configuration Data Not Present).
- f. Shall complete initialization and start alignment if STATUS DATA S1/7 (DRUH In Startup) is set and boresight data requirements have been satisfied.

C.3.2.2 Invalid configuration data. Upon activation, the DRUH shall consider changeable configuration data to be invalid if: a fault is detected where the stored configuration data may have been altered; or the configuration code number is not 15. Once rendered invalid, changeable configuration data shall not be considered valid until an ACCEPT CONFIGURATION DATA command has been accepted.

C.3.3 Configuration data output. Upon receipt of a RETURN CONFIGURATION DATA command, the DRUH shall return the values of configuration data presently being used via a CONFIGURATION DATA message.

C.3.4 Configuration data elements. The following subparagraphs describe the configuration data elements.

C.3.4.1 Configuration definition flags. The DRUH shall use configuration definition flags as indicated in the following subparagraphs. Bit references (for example, CFG D26/7) are for the RS-422 ACCEPT CONFIGURATION DATA command and are provided for identification purposes, only. The requirements apply to permanently stored and changeable configuration data. Table C-I cross-references the RS-422 CONFIGURATION DATA message and 1553 ACCEPT CONFIGURATION DATA command and CONFIGURATION DATA BLOCK message.

TABLE C-I. Configuration Definition Flags.

1553 WORD/BIT	RS-422 COMMAND BYTE/BIT	RS-422 MESSAGE BYTE/BIT	CONFIGURATION DEFINITION FLAG
W14/0	D26/7	D25/7	Orientation 2 Based on Travel Lock
W14/1	D26/6	D25/6	Orient. 1 - 2 Based on Point. Device Pitch/Roll
W14/2	D26/5	D25/5	Orient. 2 - 1 Based on Point. Device Pitch/Roll
W14/3&4	D26/4&3	D25/4&3	Orientation 1 - 2 Direction of Traverse
W14/5&6	D26/2&1	D25/2&1	Orientation 2 - 1 Direction of Traverse
W14/7	D26/0	D25/0	Orient. 2 Based on Pointing Device Attitude.
W14/8	D27/7	D26/7	GPS Installed
W14/9	D27/6	D26/6	Spare
W14/10	D27/5	D26/5	Spare
W14/11	D27/4	D26/4	Spare
W14/12	D27/3	D26/3	Integral/External Antenna
W14/13	D27/2	D26/2	Geodetic/Grid GPS Position Data
W14/14	D27/1	D26/1	GPS Command at DRUH Shutdown
W14/15	D27/0	D26/0	GPS OFF/STANDBY at DRUH Shutdown
W15/0	D28/7	D27/7	Supplier Reserved
W15/1	D28/6	D27/6	Supplier Reserved
W15/2	D28/5	D27/5	Supplier Reserved
W15/3	D28/4	D27/4	Pointing Device Roll/Cant
W15/4	D28/3	D27/3	Reset Relative Offsets
W15/5	D28/2	D27/2	Initialize Relative Output
W15/6	D28/1	D27/1	Vehicle Roll/Cant
W15/7	D28/0	D27/0	Geodetic/Grid Azimuth
W15/8	D29/7	D28/7	Pointing Device Boresight Angles
W15/9	D29/6	D28/6	Vehicle Boresight Angles
W15/10	D29/5	D28/5	Shot Detect
W15/11	D29/4	D28/4	Travel Lock Commands
W15/12	D29/3	D28/3	Travel Lock Discrete
W15/13	D29/2	D28/2	Tracked/Wheeled Vehicle
W15/14	D29/1	D28/1	Spare
W15/15	D29/0	D28/0	Odometer Installed

C.3.4.1.1 Orientation 2 based on travel lock (CFG D26/7).  
When set, the DRUH shall transition between Orientations 1 and 2 based on the state of STATUS DATA S2/4 (Pointing Device In Travel Lock).

- a. When STATUS DATA S2/4 is set, the DRUH shall operate as defined by the Orientation 1: Coordinate Frame code, Vehicle and Pointing Device Boresight Angles, and position offset distances.
- b. When STATUS DATA S2/4 is reset, the DRUH shall operate as defined by the Orientation 2: Coordinate Frame code, Pointing Device Boresight Angles, and position offset distances.

- c. While STATUS DATA S2/4 is reset, the DRUH shall output the frozen travel lock pointing device reference values in terms of Orientation 2.

When reset, the DRUH shall not change between Orientations 1 and 2 based on travel lock state.

C.3.4.1.2 Orientation transition based on attitude. When the Orientation 2 Based on Pointing Device Attitude flag (CFIG D26/0) is set, the DRUH shall transition between Orientations 1 and 2, based on Pointing Device (PD) pitch or roll and the states of the Orientation 1-2 Based on Pointing Device Pitch/Roll (CFIG D26/6), Orientation 2-1 Based on Pointing Device Pitch/Roll (CFIG D26/5), Orientation 1-2 Direction of Traverse (CFIG D26/4-3) and Orientation 2-1 Direction of Traverse (CFIG D26/2-1) flags, in accordance with Tables C-II and C-III.

When the Orientation 2 Based on Pointing Device Attitude flag (CFIG D26/0) is reset the DRUH shall not transition between Orientations 1 and 2 based on Pointing Device attitudes.

C.3.4.1.3 GPS installed (CFIG D27/7). When set, this flag indicates a GPS receiver is installed and the DRUH shall use GPS aiding unless otherwise inhibited.

When reset, the DRUH shall not use GPS aiding, communicate with the GPS receiver, or report GPS related BIT failures.

C.3.4.1.4 Spare (CFIG D27/6-4, D28/7-5 and D29/1). Spare configuration definition flags should be set to zero in ACCEPT CONFIGURATION DATA commands. Spares may be output in either state in CONFIGURATION DATA messages. CFIG D28/7-5 are supplier reserved.

TABLE C-II. Orientation 1 to 2 transition attitude flags.

CFIG D26/			THE DRUH SHALL TRANSITION FROM ORIENTATION 1 to 2 WHEN:
6	4	3	
0	0	0	Absolute value of PD roll, in terms of Orientation 1, decreases when crossing the 1-2 Threshold Angle.
0	0	1	PD roll, in terms of Orientation 1, numerically increases when crossing the 1-2 Threshold Angle
0	1	0	PD roll, in terms of Orientation 1, numerically decreases when crossing the 1-2 Threshold Angle
0	1	1	Absolute value of PD roll, in terms of Orientation 1, increases when crossing the 1-2 Threshold Angle.
1	0	0	Absolute value of PD pitch, in terms of Orientation 1, decreases when crossing the 1-2 Threshold Angle.
1	0	1	PD pitch, in terms of Orientation 1, numerically increases when crossing the 1-2 Threshold Angle
1	1	0	PD pitch, in terms of Orientation 1, numerically decreases when crossing the 1-2 Threshold Angle
1	1	1	Absolute value of PD pitch, in terms of Orientation 1, increases when crossing the 1-2 Threshold Angle.

TABLE C-III. Orientation 2 to 1 transition attitude flags.

CFIG D26/			THE DRUH SHALL TRANSITION FROM ORIENTATION 2 to 1 WHEN:
5	2	1	
0	0	0	Absolute value of PD roll, in terms of Orientation 2, decreases when crossing the 2-1 Threshold Angle.
0	0	1	PD roll, in terms of Orientation 2, numerically increases when crossing the 2-1 Threshold Angle
0	1	0	PD roll, in terms of Orientation 2, numerically decreases when crossing the 2-1 Threshold Angle
0	1	1	Absolute value of PD roll, in terms of Orientation 2, increases when crossing the 2-1 Threshold Angle.
1	0	0	Absolute value of PD pitch, in terms of Orientation 2, decreases when crossing the 2-1 Threshold Angle.
1	0	1	PD pitch, in terms of Orientation 2, numerically increases when crossing the 2-1 Threshold Angle
1	1	0	PD pitch, in terms of Orientation 2, numerically decreases when crossing the 2-1 Threshold Angle
1	1	1	Absolute value of PD pitch, in terms of Orientation 2, increases when crossing the 2-1 Threshold Angle.

C.3.4.1.5 Integral/external antenna (CFIG D27/3). This flag indicates which GPS antenna is used in the host. When set, the GPS receiver is expected to use its integral antenna. When reset, the GPS receiver is expected to use an external antenna.

C.3.4.1.6 Geodetic/grid GPS data (CFIG D27/2). When set, the DRUH shall request the GPS receiver to format position data in GPS message #5040 as Latitude and Longitude.

When reset, the DRUH shall request the GPS receiver to format position data in GPS message #5040 as UTM/UPS data, if the Host (DRUH) Grid = 1, or BNG data, if the Host (DRUH) Grid = 0.

C.3.4.1.7 GPS shutdown control. When a SHUTDOWN or STORED HEADING SHUTDOWN command has been accepted, the DRUH shall command the GPS receiver to turn off or go to stand-by, according to the states of the GPS Command at Shutdown (CFIG D27/1) and GPS OFF/Standby at Shutdown (CFIG D27/0) flags, in accordance with Table C-IV.

TABLE C-IV. GPS shutdown flags.

CFIG		GPS COMMAND AT DRUH SHUTDOWN
D27/1	D27/0	
0	0 or 1	No command at shutdown
1	0	GPS message #5001, Stand-by mode (Word 5 = 05h)
1	1	GPS message #5001, Turn RCVR off (Word 5 = 14h)

C.3.4.1.8 Pointing device roll/cant (CFIG D28/4). When set, the DRUH shall output Pointing Device Roll. When reset, the DRUH shall output Pointing Device Cant.

C.3.4.1.9 Reset relative offsets (CFIG D28/3). When set, the DRUH shall reset the relative offsets to zero and reset STATUS DATA S2/0 (Relative Offsets Determined) at initialization. When reset, the DRUH shall initialize the relative offsets to the values last determined.

C.3.4.1.10 Initialize relative output (CFIG D28/2). When set, the DRUH shall initialize to output relative (biased) positions. When reset, the DRUH shall initialize to output unbiased positions.

C.3.4.1.11 Vehicle roll/cant (CFIG D28/1). When set, the DRUH shall output Vehicle Roll. When reset, the DRUH shall output Vehicle Cant.

C.3.4.1.12 Geodetic/grid azimuth (CFIG D28/0). When set, the DRUH shall output Geodetic Azimuth in all messages providing azimuth output. When reset, the DRUH shall output Grid Azimuth, referenced to the grid specified by the Host (DRUH) Grid designation, in all messages providing azimuth output.

C.3.4.1.13 Pointing device boresight angles (CFIG D29/7). When set, the DRUH shall use Pointing Device Boresight Angles

entered via an ACCEPT POINTING DEVICE BORESIGHT command. When reset, the DRUH shall use Pointing Device Boresight Angle values stored for configuration codes 0 - 14 and values of zero for configuration code 15.

C.3.4.1.14 Vehicle boresight angles (CFIG D29/6). When set, the DRUH shall use Vehicle Boresight Angles entered via the ACCEPT VEHICLE BORESIGHT command. When reset, the DRUH shall use Vehicle Boresight Angle values stored for configuration codes 0 - 14 and values of zero for configuration code 15.

C.3.4.1.15 Shot detect (CFIG D29/5). When set, the DRUH shall set STATUS DATA S2/3 (Shot Detect) for the Shot Detect Interval when a shot is detected. When the Shot Detect flag (CFIG D29/5) is reset, STATUS DATA S2/3 shall always be reset.

C.3.4.1.16 Travel lock commands (CFIG D29/4). When set, the DRUH shall change travel lock state based on receipt of IN TRAVEL LOCK and OUT OF TRAVEL LOCK commands. At activation, the DRUH shall assume it is in travel lock when the Travel Lock Commands Flag is set.

When reset, the DRUH shall reject IN TRAVEL LOCK and OUT OF TRAVEL LOCK commands and shall set ALERT DATA D5/6 (Invalid Mode Request) if either command is received.

If both the Travel Lock Discrete and Travel Lock Commands flags are reset, the DRUH shall assume it is always in travel lock.

C.3.4.1.17 Travel lock discrete (CFIG D29/3). When set, the DRUH shall use the travel lock discrete to determine if it is in or out of travel lock. When reset, the DRUH shall ignore the travel lock discrete.

C.3.4.1.18 Tracked/wheeled vehicle (CFIG D29/2). When set, this flag indicates the host is a tracked vehicle. When reset, it indicates a wheeled vehicle.

C.3.4.1.19 Odometer installed (CFIG 29/0). When set, this flag indicates a VMS is connected and the DRUH may use useable VMS data. When reset, the DRUH shall not use VMS data or report VMS related BIT failures.

C.3.4.2 DRUH coordinate frame code. The DRUH shall use DRUH Coordinate Frame Codes, as defined in Table C-V, to relate the case coordinate frame to the intermediate DRUH Coordinate Frame (see 6.3.1), for Orientations 1 and 2.

TABLE C-V. DRUH Case Coordinate Frame Codes.

CODE (hex)	CONNECTORS	BOTTOM COVER	MOUNTING SURFACE
00	Forward	Down	Left
10	Right	Down	Forward
20	Aft	Down	Right
30	Left	Down	Aft
02	Forward	Up	Right
12	Right	Up	Aft
22	Aft	Up	Left
32	Left	Up	Forward
03	Forward	Right	Down
13	Right	Aft	Down
23	Aft	Left	Down
33	Left	Forward	Down
01	Forward	Left	Up
11	Right	Forward	Up
21	Aft	Right	Up
31	Left	Aft	Up
04	Up	Forward	Left
07	Up	Right	Forward
06	Up	Aft	Right
05	Up	Left	Aft
0E	Down	Forward	Right
0F	Down	Right	Aft
0C	Down	Aft	Left
0D	Down	Left	Forward

C.3.4.3 Vehicle boresight angles. The DRUH shall use Vehicle Boresight Angles,  $\alpha$ ,  $\beta$ ,  $\gamma$ , to calculate Vehicle Pitch, Vehicle Cant, Vehicle Roll, Vehicle Grid Azimuth, and Vehicle Geodetic Azimuth.  $\alpha$ ,  $\beta$ ,  $\gamma$  relate the DRUH coordinate frame (see 6.3.1.2) to the host vehicle coordinate frame when the DRUH is stowed for travel.

- a.  $\alpha$  is the horizontal angle between the vehicle longitudinal axis and the vertical projection of  $\overline{X}_D$  onto the horizontal plane when the vehicle longitudinal and cross axes are level.  $\alpha$  is measured clockwise from the vehicle longitudinal axis direction of travel and is always positive.
- b.  $\beta$  is the vertical angle between the vertical projection of  $\overline{X}_D$  onto the horizontal plane and  $\overline{X}_D$  when the vehicle

longitudinal and cross axes are level.  $\beta$  is negative when  $\bar{X}_D$  lies above the horizontal plane and positive when below.

- c.  $\gamma$  is the angle between the horizontal plane and  $\bar{Y}_D$  measured in the  $\bar{Y}_D, \bar{Z}_D$  plane when the vehicle longitudinal and cross axes are level.  $\gamma$  is positive when  $\bar{Y}_D$  lies below the horizontal plane and negative when above.

C.3.4.3.1 Vehicle boresight angle initialization. When the Vehicle Boresight Angles flag (CFIG D29/6) is set:

- a. The DRUH shall use valid Vehicle Boresight Angles entered via an ACCEPT VEHICLE BORESIGHT command.
- b. If Vehicle Boresight Angles are invalid, the DRUH shall: set ALERT DATA D2/7 (Vehicle Boresight Angles Not Present); set STATUS DATA S1/7 (DRUH In Startup); and reset STATUS DATA S1/4 (OK To Move), S1/5 (DRUH In Align), S2/2 (DRUH In Stored Heading Align), and S5/4 (DRUH In Dynamic Align).

When the Vehicle Boresight Angles flag (CFIG D29/6) is reset, the DRUH shall:

- a. Use Vehicle Boresight Angle values stored for configuration codes 0 - 14 and values of zero for configuration code 15.
- b. Set BIT DATA D1/7 (DRUH Fail) if Vehicle Boresight Angles are invalid.

C.3.4.3.2 ACCEPT VEHICLE BORESIGHT command response. When the Vehicle Boresight Angles flag (CFIG D29/6) is set and an ACCEPT VEHICLE BORESIGHT command is received, the DRUH:

- a. Shall accept the command if all data elements are within their allowable ranges and STATUS DATA S3/2 (DRUH in Motion) is reset.
- b. Shall reject the command and set ALERT DATA D5/2 (Invalid Data Received) if any data element is outside the allowable range.
- c. May reject the command and set ALERT DATA D3/5 (Motion During Update Request) if STATUS DATA S3/2 (DRUH in Motion) is set.

When the Vehicle Boresight Angles flag (CFIG D29/6) is reset, the DRUH shall set ALERT DATA D5/7 (Invalid Update Request) when an ACCEPT VEHICLE BORESIGHT command is received.

When an ACCEPT VEHICLE BORESIGHT command is accepted, the DRUH shall:

- a. Retain and use the new Vehicle Boresight Angles until changed or rendered invalid.
- b. Set STATUS DATA S3/7 (Orientation Transition In Progress) if orientation parameters aren't referenced to the new boresight values. STATUS DATA S3/7 shall be reset when orientation parameters are referenced to the new boresight values.
- c. Reset ALERT DATA D2/7 (Vehicle Boresight Angles Not Present).
- d. Complete initialization and start Align if STATUS DATA S1/7 (DRUH In Startup) is set and pointing device boresight and configuration data requirements have been satisfied.

C.3.4.3.3 Invalid vehicle boresight angles. Upon activation, changeable Vehicle Boresight Angles shall be invalid when: the current configuration code number differs from the configuration code number when the DRUH was last shut off; or a fault condition is detected where the stored Vehicle Boresight Angles may have been altered. Once rendered invalid, changeable Vehicle Boresight Angles shall not be considered valid until an ACCEPT VEHICLE BORESIGHT command has been accepted.

C.3.4.3.4 Output of vehicle boresight angles. Upon receipt of a RETURN VEHICLE BORESIGHT command, the DRUH shall transmit the currently used Vehicle Boresight Angles in a VEHICLE BORESIGHT Message.

C.3.4.4 Pointing device boresight angles. The DRUH shall use Orientation 1 and 2 pointing device boresight angles, A, B,  $\Gamma$ , to calculate Pointing Device Grid Azimuth, Pointing Device Geodetic Azimuth, Pointing Device Pitch, Pointing Device Cant, Pointing Device Roll, Pointing Device Pitch Rate, Pointing Device Roll Rate, and Pointing Device Azimuth Rate. A, B,  $\Gamma$  relate the DRUH coordinate frame (see 6.3.1.2) to that of the pointing device.

- a. A is the horizontal angle between the axis of the pointing device and the vertical projection of  $\bar{X}_D$  onto the horizontal plane when the pointing device axis and cross axis are level. A is measured clockwise from the direction of pointing and is always positive.

- b.  $B$  is the vertical angle between the vertical projection of  $\bar{X}_D$  onto the horizontal plane and  $\bar{X}_D$  when the pointing device axis and cross axis are level.  $B$  is negative when  $\bar{X}_D$  lies above the horizontal plane and positive below.
- c.  $\Gamma$  is the angle between the horizontal plane and  $\bar{Y}_D$  measured in the  $\bar{Y}_D, \bar{Z}_D$  plane when the pointing device axis and cross axis are level.  $\Gamma$  is positive when  $\bar{Y}_D$  lies below the horizontal plane and negative when above.

C.3.4.4.1 Pointing device boresight angle initialization.

When the Pointing Device Boresight Angles flag (CFIG D29/7) is set:

- a. The DRUH shall use valid Pointing Device Boresight Angles entered via an ACCEPT POINTING DEVICE BORESIGHT command.
- b. When Pointing Device Boresight Angles are invalid, the DRUH shall: set ALERT DATA D5/4 (Pointing Device Boresight Angles Not Present); set STATUS DATA S1/7 (DRUH In Startup); and reset STATUS DATA S1/4 (OK To Move), S1/5 (DRUH In Align), S2/2 (DRUH In Stored Heading Align), and S5/4 (DRUH In Dynamic Align).

When the Pointing Device Boresight Angles flag (CFIG D29/7) is reset, the DRUH shall:

- a. Use Pointing Device Boresight Angle values stored for configuration codes 0 - 14 and values of zero for configuration code 15.
- b. Set BIT DATA D1/7 (DRUH Fail) if Pointing Device Boresight Angles are invalid.

C.3.4.4.2 ACCEPT POINTING DEVICE BORESIGHT command response.

When the Pointing Device Boresight Angles flag (CFIG D29/7) is set and an ACCEPT POINTING DEVICE BORESIGHT command is received, the DRUH:

- a. Shall accept the command if all data elements are within their allowable ranges and STATUS DATA S3/2 (DRUH in Motion) is reset.
- b. Shall reject the command and set ALERT DATA D5/2 (Invalid Data Received) if any data element is outside the allowable range.

- c. May reject the command and set ALERT DATA D3/5 (Motion During Update Request) if STATUS DATA S3/2 (DRUH in Motion) is set.

When the Pointing Device Boresight Angles flag (CFIG D29/7) is reset, the DRUH shall set ALERT DATA D5/7 (Invalid Update Request) when an ACCEPT POINTING DEVICE BORESIGHT command is received.

When an ACCEPT POINTING DEVICE BORESIGHT command is accepted, the DRUH shall:

- a. Retain and use the new Pointing Device Boresight Angles until changed or rendered invalid.
- b. Set STATUS DATA S3/7 (Orientation Transition In Progress) if orientation parameters aren't referenced to the new boresight values. STATUS DATA S3/7 shall be reset when orientation parameters are referenced to the new boresight values.
- c. Reset ALERT DATA D5/4 (Pointing Device Angles Not Present).
- d. Complete initialization and start Align if STATUS DATA S1/7 (DRUH In Startup) is set and vehicle boresight and configuration data requirements have been satisfied.

C.3.4.4.3 Invalid pointing device boresight angles. Upon activation, changeable Pointing Device Boresight Angles shall be invalid when: the current configuration code number differs from the configuration code number when the DRUH was last shut off; or a fault condition is detected where the stored Pointing Device Boresight Angles may have been altered. Once rendered invalid, changeable Pointing Device Boresight Angles shall not be considered valid until an ACCEPT POINTING DEVICE BORESIGHT command has been accepted.

C.3.4.4.4 Output of pointing device boresight angles. Upon receipt of a RETURN POINTING DEVICE BORESIGHT command, the DRUH shall transmit the currently used pointing device boresight angles in a POINTING DEVICE BORESIGHT message.

C.3.4.5 Position offset distances. The DRUH shall use position offset distances to transfer positions to/from a reference point on the host. There shall be separate sets of position offset distances for Orientation 1, Orientation 2, GPS antenna reference points and odometer action point.

C.3.4.5.1 Orientation 1 offset distances. In Orientation 1, the position offset distances,  $\Delta X$ ,  $\Delta Y$ , and  $\Delta Z$ , are in the

vehicle coordinate frame and are measured from the DRUH case reference frame origin.

- a.  $\Delta X$ , the offset along the vehicle longitudinal axis, is positive if the offset point is forward of the DRUH in the direction of travel and is negative if behind.
- b.  $\Delta Y$ , the offset along the vehicle cross axis, is positive if the offset point is to the right of the DRUH, looking in the direction of forward travel, and is negative if to the left.
- c.  $\Delta Z$ , the offset along the vehicle vertical axis, is positive if the offset point is above the DRUH and is negative if below.

C.3.4.5.2 Orientation 2 offset distances. In Orientation 2, the position offset distances,  $\Delta X$ ,  $\Delta Y$ , and  $\Delta Z$ , are in the pointing device coordinate frame. They are measured from the DRUH case reference frame origin to the offset point on the pointing device when the pointing device pointing axis and cross-axis are level.

- a.  $\Delta X$ , the offset along the pointing device pointing axis, is positive if the offset point is forward of the DRUH in the direction of pointing and is negative if behind.
- b.  $\Delta Y$ , the offset along the pointing device cross-axis, is positive if the offset point is to the right of the DRUH, looking in the direction of pointing, and is negative if to the left.
- c.  $\Delta Z$ , the offset along the pointing device vertical axis, is positive if the offset point is above the DRUH and is negative if below.

C.3.4.5.3 GPS antenna offset distances. The DRUH shall use GPS antenna offset distances to compensate GPS data from the GPS antenna location to the DRUH case reference frame origin. The offset distances from the DRUH to the GPS antenna,  $\Delta X$ ,  $\Delta Y$ , and  $\Delta Z$ , are in a local level coordinate frame when the vehicle is level. GPS antenna offset distances are measured from the DRUH case reference frame origin.

- a.  $\Delta X$ , the offset along the vehicle longitudinal axis, is positive if the antenna is forward of the DRUH in the direction of travel and is negative if behind.

- b.  $\Delta Y$ , the offset along the vehicle cross axis, is positive if the antenna is to the right of the DRUH, looking in the direction of forward travel, and is negative if to the left.
- c.  $\Delta Z$ , the offset along the vehicle vertical axis, is positive if the antenna is above the DRUH and is negative if below.

The DRUH may use the same GPS offset distances in Orientations 1 and 2. Only one set is specified in the ACCEPT CONFIGURATION DATA commands and CONFIGURATION DATA messages.

C.3.4.5.4 Odometer action offset distances. The DRUH may use the offset distances from the DRUH to the odometer action point,  $\Delta X$ ,  $\Delta Y$ , and  $\Delta Z$ . These offsets are in the vehicle coordinate frame with the DRUH operating in Orientation 1 (pointing device in travel lock or ready for travel) and are measured from the DRUH case reference frame origin.

- a.  $\Delta X$ , the offset along the vehicle longitudinal axis, is positive if the action point is forward of the DRUH in the direction of travel and is negative if behind.
- b.  $\Delta Y$ , the offset along the vehicle cross axis, is positive if the action point is to the right of the DRUH, looking in the direction of forward travel, and is negative if to the left.
- c.  $\Delta Z$ , the offset along the vehicle vertical axis, is positive if the action point is above the DRUH and is negative if below.

#### C.3.4.6 Time intervals.

C.3.4.6.1 Exclusive ZUPT mode ZUPT interval. The DRUH may request ZUPTs at no more frequent intervals than the Exclusive ZUPT Mode ZUPT Interval when usable GPS and VMS aiding data are not available.

C.3.4.6.2 Odometer mode ZUPT interval. The DRUH may request ZUPTs at no more frequent intervals than the Odometer Mode ZUPT Interval when usable GPS aiding data are not available and usable VMS data are available.

C.3.4.6.3 Static align time. The DRUH shall complete Static Align within the Static Align time.

C.3.4.6.4 Shot detect interval. When the Shot Detect flag (CFIG D29/5) is set, the DRUH shall set STATUS DATA S2/3 (Shot Detect) for the Shot Detect Interval when a shot is detected.

When the Shot Detect flag (CFIG D29/5) is reset, STATUS DATA S2/3 shall always be reset and an ACCEPT CONFIGURATION DATA command shall not be rejected for an out-of-range Shot Detect Interval.

C.3.4.6.5 GPS update time-out interval. The DRUH shall reset STATUS DATA S5/7 (GPS Damping In Process) if the time since the last usable GPS update exceeds the GPS Update Time-out Interval.

C.3.4.7 Odometer scale factor. The DRUH may use the nominal odometer scale factor which is [(nominal number of VMS pulses/mile)/(32000 pulses/mile)].

C.3.4.8 Fuel consumption factor. The DRUH may use the Fuel Consumption Factor which is the change in vehicle pitch per unit distance traveled due to consumption of fuel.

C.3.4.9 Threshold angles. When the Orientation 2 Based on Pointing Device Attitude flag (CFIG D26/0) is set, the DRUH shall change orientations when the 1-2 or 2-1 Threshold Angle is crossed.

C.3.4.9.1 1-2 threshold angle. The DRUH shall transition from Orientation 1 to 2 when the 1-2 Threshold Angle is crossed in the direction specified by the Orientation 1-2 Direction of Traverse flags (CFIG D26/4 & 3). The 1-2 Threshold Angle is specified in terms of Orientation 1.

C.3.4.9.2 2-1 threshold angle. The DRUH shall transition from Orientation 2 to 1 when the 2-1 Threshold Angle is crossed in the direction specified by the Orientation 2-1 Direction of Traverse flags (CFIG D26/2 & 1). The 2-1 Threshold Angle is specified in terms of Orientation 2.

C.3.4.10 GPS EPE criteria.

C.3.4.10.1 GPS EPE good value. When the GPS EPE (estimated position error) associated with a GPS position update is less than or equal to the GPS EPE Good Value, the DRUH may accept the update.

C.3.4.10.2 GPS EPE poor value. When the GPS EPE associated with a GPS position update is less than or equal to the GPS EPE Poor Value but greater than the GPS EPE Good Value, the DRUH may accept the update only if STATUS DATA S6/6 (Degraded GPS Enabled) is set.

When the GPS EPE associated with a GPS position update is greater than the GPS Poor Value, the DRUH shall reject the update.

The DRUH may require the GPS EPE Poor Value to be greater than the GPS EPE Good Value.

C.3.5 Permanently stored configuration data. Permanently stored configuration data shall be reprogrammable, via the GPS RS-422 and 1553 reprogramming interfaces, separately from the survey software. Values for permanently stored configuration data shall be as listed in Table C-VI. The allowable ranges for permanently stored configuration data values shall be no less than those for the corresponding elements in the ACCEPT CONFIGURATION DATA command. The resolution for permanently stored configuration data values shall be no coarser than for the corresponding elements in the ACCEPT CONFIGURATION DATA command.

TABLE C-VI. Permanently stored configuration data.

CODE	HOST	CONFIG. DISCRETE	1234	1234	1234	1234
0	- Paladin		0000			
1	- unassigned			0001		
2	- AN/TPQ-36 (V)				0010	
3	- unassigned	UNITS				0011
DRUH COORDINATE FRAME CODE:						
	Orientation 1:	hex	00	00	03	00
	Orientation 2:	hex	00	00	03	00
BORESIGHT ANGLES:						
	Vehicle Orientation $\alpha$ :	mils	0.0	0.0	0.0	0.0
	Vehicle Orientation $\beta$ :	mils	0.0	0.0	0.0	0.0
	Vehicle Orientation $\gamma$ :	mils	0.0	0.0	0.0	0.0
	Pointing Device Orient. 1 A:	mils	0.0	0.0	0.0	0.0
	Pointing Device Orient. 1 B:	mils	0.0	0.0	0.0	0.0
	Pointing Device Orient. 1 $\Gamma$ :	mils	0.0	0.0	0.0	0.0
	Pointing Device Orient. 2 A:	mils	0.0	0.0	0.0	0.0
	Pointing Device Orient. 2 B:	mils	0.0	0.0	0.0	0.0
	Pointing Device Orient. 2 $\Gamma$ :	mils	0.0	0.0	0.0	0.0
ZRP OFFSET DISTANCES:						
	Orientation 1 Vehicle $\Delta X$ :	meters	0.00	0.00	1.00	0.00
	Orientation 1 Vehicle $\Delta Y$ :	meters	0.00	0.00	0.45	0.00
	Orientation 1 Vehicle $\Delta Z$ :	meters	0.00	0.00	-0.86	0.00
	Orientation 2 PD $\Delta X$ :	meters	0.00	0.00	0.00	0.00
	Orientation 2 PD $\Delta Y$ :	meters	0.00	0.00	0.00	0.00
	Orientation 2 PD $\Delta Z$ :	meters	0.00	0.00	0.00	0.00
	Odometer Action Point 1 $\Delta X$ :	meters	0.80	0.00	0.40	0.00
	Odometer Action Point 1 $\Delta Y$ :	meters	-1.59	0.00	-0.42	0.00
	Odometer Action Point 1 $\Delta Z$ :	meters	-1.92	0.00	-0.56	0.00
	GPS Antenna $\Delta X$ :	meters	-3.02	0.00	-0.02	0.00
	GPS Antenna $\Delta Y$ :	meters	-2.19	0.00	-0.19	0.00
	GPS Antenna $\Delta Z$ :	meters	1.50	0.00	1.05	0.00
TIME INTERVALS:						
	ZUPT (Exclusive ZUPT Mode):	minutes	4.00	4.00	4.00	4.00
	ZUPT (Odometer Mode):	minutes	60	60	60	60
	Static Align Time:	minutes	15.00	15.00	15.00	15.00
	Shot Detect Interval:	seconds	4	0	0	0
	GPS Update Time-out Interval:	seconds	20	20	20	20
VMS SCALE FACTOR:						
	VMS Scale Factor:	n/a	1.000	1.000	1.000	1.000
FUEL CONSUMPTION FACTOR:						
	Consumption Factor:	$\mu$ -rad/km	-42.0	0.0	0.0	0.0
THRESHOLD ANGLES:						
	1-2 Threshold Angle:	mils	0.0	0.0	0.0	0.0
	2-1 Threshold Angle:	mils	0.0	0.0	0.0	0.0
GPS ACCEPTANCE CRITERIA:						
	EPE 'Good' Criteria:	meters	16	16	16	16
	EPE 'Poor' Criteria:	meters	76	76	76	76

TABLE C-VI. Permanently stored configuration data.(Continued)

CODE	HOST	CONFIG. DISCRETE	1234	1234	1234	1234
0	-	Paladin	0000			
1	-	unassigned		0001		
2	-	AN/TPQ-36 (V)			0010	
3	-	unassigned				0011
1553 *	RS-422 *	MODE OR CONDITION	0	1	2	3
WORD/BIT	CHAR/BIT					
W14/0	D26/7	Orient. 2 Based on Travel Lock	1	0	0	0
W14/1	D26/6	Orient. 1-2 Based on PD P/R	0	0	0	0
W14/2	D26/5	Orient. 2-1 Based on PD P/R	0	0	0	0
W14/3&4	D26/4&3	Orient. 1-2 Dir. of Traverse	00	00	00	00
W14/5&6	D26/2&1	Orient. 2-1 Dir. of Traverse	00	00	00	00
W14/7	D26/0	Orient. 2 Based on PD Attitude	0	0	0	0
W14/8	D27/7	GPS Installed.	1	0	1	0
W14/9	D27/6	Spare	1	0	0	0
W14/10	D27/5	Spare	0	0	0	0
W14/11	D27/4	Spare	1	0	0	0
W14/12	D27/3	Integral/External Antenna.	0	0	0	0
W14/13	D27/2	Geodetic/Grid GPS Data	0	0	0	0
W14/14	D27/1	GPS Command at Shutdown	1	0	0	0
W14/15	D27/0	OFF/STANDBY at Shutdown	0	0	0	0
W15/0	D28/7	Supplier Reserved	0	0	0	0
W15/1	D28/6	Supplier Reserved	0	0	0	0
W15/2	D28/5	Supplier Reserved	0	0	0	0
W15/3	D28/4	Pointing Device Roll/Cant	0	0	0	0
W15/4	D28/3	Reset Relative Offsets	0	0	0	0
W15/5	D28/2	Initial Relative Output	1	0	1	0
W15/6	D28/1	Vehicle Roll/Cant	0	0	0	0
W15/7	D28/0	Geodetic/Grid Azimuth	0	0	0	0
W15/8	D29/7	PD Boresight Angles	1	0	0	0
W15/9	D29/6	Vehicle Boresight Angles	1	0	0	0
W15/10	D29/5	Shot Detect	1	0	0	0
W15/11	D29/4	Travel Lock Commands	1	0	0	0
W15/12	D29/3	Travel Lock Discretes	0	0	0	0
W15/13	D29/2	Tracked/Wheeled Vehicle	1	0	0	0
W15/14	D29/1	Spare	0	0	0	0
W15/15	D29/0	Odometer Installed	1	0	1	0

\* Word and character bit references to the ACCEPT CONFIGURATION DATA commands are for reference, only.

TABLE C-VI. Permanently stored configuration data. (Continued)

CODE	HOST	CONFIG. DISCRETE	1234	1234	1234	1234	
4	-	unassigned	0100				
5	-	unassigned		0101			
6	-	unassigned			0110		
7	-	unassigned				0111	
		<b>UNITS</b>					
DRUH COORDINATE FRAME CODE:							
		Orientation 1:	hex	00	00	00	00
		Orientation 2:	hex	00	00	00	00
BORESIGHT ANGLES:							
		Vehicle Orientation $\alpha$ :	mils	0.0	0.0	0.0	0.0
		Vehicle Orientation $\beta$ :	mils	0.0	0.0	0.0	0.0
		Vehicle Orientation $\gamma$ :	mils	0.0	0.0	0.0	0.0
		Pointing Device Orient. 1 A:	mils	0.0	0.0	0.0	0.0
		Pointing Device Orient. 1 B:	mils	0.0	0.0	0.0	0.0
		Pointing Device Orient. 1 $\Gamma$ :	mils	0.0	0.0	0.0	0.0
		Pointing Device Orient. 2 A:	mils	0.0	0.0	0.0	0.0
		Pointing Device Orient. 2 B:	mils	0.0	0.0	0.0	0.0
		Pointing Device Orient. 2 $\Gamma$ :	mils	0.0	0.0	0.0	0.0
ZRP OFFSET DISTANCES:							
		Orientation 1 Vehicle $\Delta X$ :	meters	0.00	0.00	0.00	0.00
		Orientation 1 Vehicle $\Delta Y$ :	meters	0.00	0.00	0.00	0.00
		Orientation 1 Vehicle $\Delta Z$ :	meters	0.00	0.00	0.00	0.00
		Orientation 2 PD $\Delta X$ :	meters	0.00	0.00	0.00	0.00
		Orientation 2 PD $\Delta Y$ :	meters	0.00	0.00	0.00	0.00
		Orientation 2 PD $\Delta Z$ :	meters	0.00	0.00	0.00	0.00
		Odometer Action Point 1 $\Delta X$ :	meters	0.00	0.00	0.00	0.00
		Odometer Action Point 1 $\Delta Y$ :	meters	0.00	0.00	0.00	0.00
		Odometer Action Point 1 $\Delta Z$ :	meters	0.00	0.00	0.00	0.00
		GPS Antenna $\Delta X$ :	meters	0.00	0.00	0.00	0.00
		GPS Antenna $\Delta Y$ :	meters	0.00	0.00	0.00	0.00
		GPS Antenna $\Delta Z$ :	meters	0.00	0.00	0.00	0.00
TIME INTERVALS:							
		ZUPT (Exclusive ZUPT Mode):	minutes	4.00	4.00	4.00	4.00
		ZUPT (Odometer Mode):	minutes	60	60	60	60
		Static Align Time:	minutes	15.00	15.00	15.00	15.00
		Shot Detect Interval:	seconds	0	0	0	0
		GPS Update Time-out Interval:	seconds	20	20	20	20
VMS SCALE FACTOR:							
		VMS Scale Factor:	n/a	1.000	1.000	1.000	1.000
FUEL CONSUMPTION FACTOR:							
		Consumption Factor:	$\mu$ -rad/km	0.0	0.0	0.0	0.0
THRESHOLD ANGLES:							
		1-2 Threshold Angle:	mils	0.0	0.0	0.0	0.0
		2-1 Threshold Angle:	mils	0.0	0.0	0.0	0.0
GPS ACCEPTANCE CRITERIA:							
		EPE 'Good' Criteria:	meters	16	16	16	16
		EPE 'Poor' Criteria:	meters	76	76	76	76

TABLE C-VI. Permanently stored configuration data (Continued)

CODE	HOST	CONFIG. DISCRETE	1234	1234	1234	1234
4	-	unassigned	0100			
5	-	unassigned		0101		
6	-	unassigned			0110	
7	-	unassigned				0111
1553 WORD/BIT	RS-422 CHAR/BIT	MODE OR CONDITION	4	5	6	7
W14/0	D26/7	Orient. 2 Based on Travel Lock	0	0	0	0
W14/1	D26/6	Orient. 1-2 Based on PD P/R	0	0	0	0
W14/2	D26/5	Orient. 2-1 Based on PD P/R	0	0	0	0
W14/3&4	D26/4&3	Orient. 1-2 Dir. of Traverse	00	00	00	00
W14/5&6	D26/2&1	Orient. 2-1 Dir. of Traverse	00	00	00	00
W14/7	D26/0	Orient. 2 Based on PD Attitude	0	0	0	0
W14/8	D27/7	GPS Installed.	0	0	0	0
W14/9	D27/6	Spare	0	0	0	0
W14/10	D27/5	Spare	0	0	0	0
W14/11	D27/4	Spare	0	0	0	0
W14/12	D27/3	Integral/External Antenna	0	0	0	0
W14/13	D27/2	Geodetic/Grid GPS Data	0	0	0	0
W14/14	D27/1	GPS Command at Shutdown	0	0	0	0
W14/15	D27/0	OFF/STANDBY at Shutdown	0	0	0	0
W15/0	D28/7	Supplier Reserved	0	0	0	0
W15/1	D28/6	Supplier Reserved	0	0	0	0
W15/2	D28/5	Supplier Reserved	0	0	0	0
W15/3	D28/4	Pointing Device Roll/Cant	0	0	0	0
W15/4	D28/3	Reset Relative Offsets	0	0	0	0
W15/5	D28/2	Initialize Relative Output	0	0	0	0
W15/6	D28/1	Vehicle Roll/Cant	0	0	0	0
W15/7	D28/0	Geodetic/Grid Azimuth	0	0	0	0
W15/8	D29/7	PD Boresight Angles	0	0	0	0
W15/9	D29/6	Vehicle Boresight Angles	0	0	0	0
W15/10	D29/5	Shot Detect	0	0	0	0
W15/11	D29/4	Travel Lock Commands	0	0	0	0
W15/12	D29/3	Travel Lock Discrettes	0	0	0	0
W15/13	D29/2	Tracked/Wheeled Vehicle	0	0	0	0
W15/14	D29/1	Spare	0	0	0	0
W15/15	D29/0	Odometer Installed	0	0	0	0

TABLE C-VI. Permanently stored configuration data. (Continued)

CODE	HOST	CONFIG. DISCRETE	1234	1234	1234	1234
8	- unassigned		1000			
9	- unassigned			1001		
10	- unassigned				1010	
11	- unassigned	UNITS				1011
DRUH COORDINATE FRAME CODE:						
	Orientation 1:	hex	00	00	00	00
	Orientation 2:	hex	00	00	00	00
BORESIGHT ANGLES :						
	Vehicle Orientation $\alpha$ :	mils	0.0	0.0	0.0	0.0
	Vehicle Orientation $\beta$ :	mils	0.0	0.0	0.0	0.0
	Vehicle Orientation $\gamma$ :	mils	0.0	0.0	0.0	0.0
	Pointing Device Orient. 1 A:	mils	0.0	0.0	0.0	0.0
	Pointing Device Orient. 1 B:	mils	0.0	0.0	0.0	0.0
	Pointing Device Orient. 1 $\Gamma$ :	mils	0.0	0.0	0.0	0.0
	Pointing Device Orient. 2 A:	mils	0.0	0.0	0.0	0.0
	Pointing Device Orient. 2 B:	mils	0.0	0.0	0.0	0.0
	Pointing Device Orient. 2 $\Gamma$ :	mils	0.0	0.0	0.0	0.0
ZRP OFFSET DISTANCES :						
	Orientation 1 Vehicle $\Delta X$ :	meters	0.00	0.00	0.00	0.00
	Orientation 1 Vehicle $\Delta Y$ :	meters	0.00	0.00	0.00	0.00
	Orientation 1 Vehicle $\Delta Z$ :	meters	0.00	0.00	0.00	0.00
	Orientation 2 PD $\Delta X$ :	meters	0.00	0.00	0.00	0.00
	Orientation 2 PD $\Delta Y$ :	meters	0.00	0.00	0.00	0.00
	Orientation 2 PD $\Delta Z$ :	meters	0.00	0.00	0.00	0.00
	Odometer Action Point 1 $\Delta X$ :	meters	0.00	0.00	0.00	0.00
	Odometer Action Point 1 $\Delta Y$ :	meters	0.00	0.00	0.00	0.00
	Odometer Action Point 1 $\Delta Z$ :	meters	0.00	0.00	0.00	0.00
	GPS Antenna $\Delta X$ :	meters	0.00	0.00	0.00	0.00
	GPS Antenna $\Delta Y$ :	meters	0.00	0.00	0.00	0.00
	GPS Antenna $\Delta Z$ :	meters	0.00	0.00	0.00	0.00
TIME INTERVALS:						
	ZUPT (Exclusive ZUPT Mode):	minutes	4.00	4.00	4.00	4.00
	ZUPT (Odometer Mode):	minutes	60	60	60	60
	Static Align Time:	minutes	15.00	15.00	15.00	15.00
	Shot Detect Interval:	seconds	0	0	0	0
	GPS Update Time-out Interval	seconds	20	20	20	20
VMS SCALE FACTOR:						
	VMS Scale Factor:	n/a	1.000	1.000	1.000	1.000
FUEL CONSUMPTION FACTOR:						
	Consumption Factor:	$\mu$ -rad/km	0.0	0.0	0.0	0.0
THRESHOLD ANGLES:						
	1-2 Threshold Angle:	mils	0.0	0.0	0.0	0.0
	2-1 Threshold Angle:	mils	0.0	0.0	0.0	0.0
GPS ACCEPTANCE CRITERIA:						
	EPE 'Good' Criteria:	meters	16	16	16	16
	EPE 'Poor' Criteria:	meters	76	76	76	76

TABLE C-VI. Permanently stored configuration data. (Continued)

CODE		HOST	CONFIG. DISCRETE	1234	1234	1234	1234
8		-	unassigned	0100			
9		-	unassigned		0101		
10		-	unassigned			0110	
11		-	unassigned				0111
1553 WORD/BIT	RS-422 CHAR/BIT	MODE OR CONDITION		8	9	10	11
W14/0	D26/7	Orient. 2 Based on Travel Lock		0	0	0	0
W14/1	D26/6	Orient. 1-2 Based on PD P/R		0	0	0	0
W14/2	D26/5	Orient. 2-1 Based on PD P/R		0	0	0	0
W14/3&4	D26/4&3	Orient. 1-2 Dir. of Traverse		00	00	00	00
W14/5&6	D26/2&1	Orient. 2-1 Dir. of Traverse		00	00	00	00
W14/7	D26/0	Orient. 2 Based on PD Attitude		0	0	0	0
W14/8	D27/7	GPS Installed.		0	0	0	0
W14/9	D27/6	Spare		0	0	0	0
W14/10	D27/5	Spare		0	0	0	0
W14/11	D27/4	Spare		0	0	0	0
W14/12	D27/3	Integral/External Antenna		0	0	0	0
W14/13	D27/2	Geodetic/Grid GPS Data		0	0	0	0
W14/14	D27/1	GPS Command at Shutdown		0	0	0	0
W14/15	D27/0	OFF/STANDBY at Shutdown		0	0	0	0
W15/0	D28/7	Supplier Reserved		0	0	0	0
W15/1	D28/6	Supplier Reserved		0	0	0	0
W15/2	D28/5	Supplier Reserved		0	0	0	0
W15/3	D28/4	Pointing Device Roll/Cant		0	0	0	0
W15/4	D28/3	Reset Relative Offsets		0	0	0	0
W15/5	D28/2	Initialize Relative Output		0	0	0	0
W15/6	D28/1	Vehicle Roll/Cant		0	0	0	0
W15/7	D28/0	Geodetic/Grid Azimuth		0	0	0	0
W15/8	D29/7	PD Boresight Angles		0	0	0	0
W15/9	D29/6	Vehicle Boresight Angles		0	0	0	0
W15/10	D29/5	Shot Detect		0	0	0	0
W15/11	D29/4	Travel Lock Commands		0	0	0	0
W15/12	D29/3	Travel Lock Discrettes		0	0	0	0
W15/13	D29/2	Tracked/Wheeled Vehicle		0	0	0	0
W15/14	D29/1	Spare		0	0	0	0
W15/15	D29/0	Odometer Installed		0	0	0	0

TABLE C-VI. Permanently stored configuration data.(Continued)

CODE	HOST	CONFIG. DISCRETE	1234	1234	1234	1234
12 - AN/TPQ-37 (V)			1100			
13 - unassigned				1101		
14 - unassigned					1110	
15 - ACCEPT CONFIG. DATA cmd.		UNITS				0111
DRUH COORDINATE FRAME CODE:						
Orientation 1:	hex	00	00	00	00	n/a
Orientation 2:	hex	00	00	00	00	n/a
BORESIGHT ANGLES:						
Vehicle Orientation $\alpha$ :	mils	0.0	0.0	0.0	0.0	n/a
Vehicle Orientation $\beta$ :	mils	0.0	0.0	0.0	0.0	n/a
Vehicle Orientation $\gamma$ :	mils	0.0	0.0	0.0	0.0	n/a
Pointing Device Orient. 1 A:	mils	0.0	0.0	0.0	0.0	n/a
Pointing Device Orient. 1 B:	mils	0.0	0.0	0.0	0.0	n/a
Pointing Device Orient. 1 $\Gamma$ :	mils	0.0	0.0	0.0	0.0	n/a
Pointing Device Orient. 2 A:	mils	0.0	0.0	0.0	0.0	n/a
Pointing Device Orient. 2 B:	mils	0.0	0.0	0.0	0.0	n/a
Pointing Device Orient. 2 $\Gamma$ :	mils	0.0	0.0	0.0	0.0	n/a
ZRP OFFSET DISTANCES:						
Orientation 1 Vehicle $\Delta X$ :	meters	0.00	0.00	0.00	0.00	n/a
Orientation 1 Vehicle $\Delta Y$ :	meters	0.00	0.00	0.00	0.00	n/a
Orientation 1 Vehicle $\Delta Z$ :	meters	0.00	0.00	0.00	0.00	n/a
Orientation 2 PD $\Delta X$ :	meters	0.00	0.00	0.00	0.00	n/a
Orientation 2 PD $\Delta Y$ :	meters	0.00	0.00	0.00	0.00	n/a
Orientation 2 PD $\Delta Z$ :	meters	0.00	0.00	0.00	0.00	n/a
Odometer Action Point 1 $\Delta X$ :	meters	0.00	0.00	0.00	0.00	n/a
Odometer Action Point 1 $\Delta Y$ :	meters	0.00	0.00	0.00	0.00	n/a
Odometer Action Point 1 $\Delta Z$ :	meters	0.00	0.00	0.00	0.00	n/a
GPS Antenna $\Delta X$ :	meters	0.00	0.00	0.00	0.00	n/a
GPS Antenna $\Delta Y$ :	meters	0.00	0.00	0.00	0.00	n/a
GPS Antenna $\Delta Z$ :	meters	0.00	0.00	0.00	0.00	n/a
TIME INTERVALS:						
ZUPT (Exclusive ZUPT Mode):	minutes	4.00	4.00	4.00	4.00	n/a
ZUPT (Odometer Mode):	minutes	60	60	60	60	n/a
Static Align Time:	minutes	15.00	15.00	15.00	15.00	n/a
Shot Detect Interval:	seconds	0	0	0	0	n/a
GPS Update Time-out Interval:	seconds	20	20	20	20	n/a
VMS SCALE FACTOR:						
VMS Scale Factor:	n/a	1.000	1.000	1.000	1.000	n/a
FUEL CONSUMPTION FACTOR:						
Consumption Factor:	$\mu$ -rad/km	0.0	0.0	0.0	0.0	n/a
THRESHOLD ANGLES:						
1-2 Threshold Angle:	mils	0.0	0.0	0.0	0.0	n/a
2-1 Threshold Angle:	mils	0.0	0.0	0.0	0.0	n/a
GPS ACCEPTANCE CRITERIA:						
EPE 'Good' Criteria:	meters	16	16	16	16	n/a
EPE 'Poor' Criteria:	meters	76	76	76	76	n/a

TABLE C-VI. Permanently stored configuration data.(Continued)

CODE	HOST	CONFIG. DISCRETE	1234	1234	1234	1234
12	- AN/TPQ-37 (V)		1100			
13	- unassigned			1101		
14	- unassigned				1110	
15	- use ACCEPT CONFIGURATION DATA cmd.					1111
1553 WORD/BIT	RS-422 CHAR/BIT	MODE OR CONDITION	12	13	14	15
W14/0	D26/7	Orient. 2 Based on Travel Lock	0	0	0	n/a
W14/1	D26/6	Orient. 1-2 Based on PD P/R	0	0	0	n/a
W14/2	D26/5	Orient. 2-1 Based on PD P/R	0	0	0	n/a
W14/3&4	D26/4&3	Orient. 1-2 Dir. of Traverse	00	00	00	n/a
W14/5&6	D26/2&1	Orient. 2-1 Dir. of Traverse	00	00	00	n/a
W14/7	D26/0	Orient. 2 Based on PD Attitude	0	0	0	n/a
W14/8	D27/7	GPS Installed.	0	0	0	n/a
W14/9	D27/6	Spare	0	0	0	n/a
W14/10	D27/5	Spare	0	0	0	n/a
W14/11	D27/4	Spare	0	0	0	n/a
W14/12	D27/3	Integral/External Antenna	0	0	0	n/a
W14/13	D27/2	Geodetic/Grid GPS Data	0	0	0	n/a
W14/14	D27/1	GPS Command at Shutdown	0	0	0	n/a
W14/15	D27/0	OFF/STANDBY at Shutdown	0	0	0	n/a
W15/0	D28/7	Supplier Reserved	0	0	0	n/a
W15/1	D28/6	Supplier Reserved	0	0	0	n/a
W15/2	D28/5	Supplier Reserved	0	0	0	n/a
W15/3	D28/4	Pointing Device Roll/Cant	0	0	0	n/a
W15/4	D28/3	Reset Relative Offsets	0	0	0	n/a
W15/5	D28/2	Initialize Relative Output	0	0	0	n/a
W15/6	D28/1	Vehicle Roll/Cant	0	0	0	n/a
W15/7	D28/0	Geodetic/Grid Azimuth	0	0	0	n/a
W15/8	D29/7	PD Boresight Angles	0	0	0	n/a
W15/9	D29/6	Vehicle Boresight Angles	0	0	0	n/a
W15/10	D29/5	Shot Detect	0	0	0	n/a
W15/11	D29/4	Travel Lock Commands	0	0	0	n/a
W15/12	D29/3	Travel Lock Discretes	0	0	0	n/a
W15/13	D29/2	Tracked/Wheeled Vehicle	0	0	0	n/a
W15/14	D29/1	Spare	0	0	0	n/a
W15/15	D29/0	Odometer Installed	0	0	0	n/a

## APPENDIX D

## DRUH/HOST MIL-STD-1553 DATA INTERFACE

## D.1. SCOPE

D.1.1 Scope. This appendix provides the requirements for a DRUH/host digital data interface using MIL-STD-1553 data buses. This appendix is a mandatory part of this specification. The information herein is intended for compliance.

## D.2. APPLICABLE DOCUMENTS

D.2.1 General. The documents listed in this section are specified in section 3 of this appendix. This section does not include documents in other sections of this specification or recommended for additional information or as examples. While every effort has been made to ensure the completeness of this list, document users are cautioned that they must meet all specified requirements documents cited in section 3 of this appendix, whether or not they are listed.

D.2.2 Government documents.

D.2.2.1 Specifications, standards, and handbooks. The following specifications, standards, and handbooks form a part of this appendix to the extent specified herein. Unless otherwise specified, the issues of these documents are those listed in the issue of the Department of Defense Index of Specifications and Standards (DODISS) and supplement thereto, cited in the solicitation (see 6.2).

## STANDARDS

## DEPARTMENT OF DEFENSE

MIL-STD-1553      Digital Time Division Command/Response  
Multiplex Data Bus

(Unless otherwise indicated, copies of the above specifications, standards, and handbooks are available from the Standardization Document Order Desk, Bldg. 4D, 700 Robbins Avenue, Philadelphia, PA 19111-5094.)

D.2.2.2 Other Government documents, drawings, and publications. The following other Government documents, drawings, and publications form a part of this document to the extent specified herein. Unless otherwise specified, the issues are those cited in the solicitation (see 6.2).

## OTHER GOVERNMENT DOCUMENTS

ICD-GPS-153	GPS User Equipment Interface Control
IRN-001	Document for the RS-232/RS-422
IRN-002	Interface of DoD Standard GPS UE Radio Receivers

(Copies of ICD-GPS-153 may be obtained from the Global Positioning System (GPS) Joint Program Office (JPO), SMC/CZ, SMC/CZ, 2435 Vela Way, Suite 1613, Los Angeles Air Force Base, El Segundo, CA 90245-5500.)

D.2.3 Order of precedence. In the event of a conflict between the text of this document and the references cited herein, the text of this document shall take precedence. Nothing in this document, however, supersedes applicable laws and regulations unless a specific exemption has been obtained.

## D.3. REQUIREMENTS

D.3.1 MIL-STD-1553 data bus. The DRUH shall be capable of data transfer between itself and the host system via a dual standby-redundant digital data bus in accordance with MIL-STD-1553. The DRUH shall function as a remote terminal (RT) on the data bus.

The DRUH RT shall implement the following MIL-STD-1553 non-broadcast and broadcast message formats, as a minimum:

- a. Mode commands,
- b. RT to BC transfers (transmit),
- c. BC to RT transfers (receive), and
- d. RT to RT transfers (receive and transmit).

D.3.1.1 Bus termination. DRUH 1553 data bus connections shall accept transformer coupled stubs as shown in Figure 9 of MIL-STD-1553.

D.3.1.2 Bus address and parity. The 1553 data bus terminal address shall be programmable via five discrete inputs on J3 to provide any address from 0 to 31. A sixth discrete input shall be used to produce odd ones parity for the terminal address.

An open circuit shall indicate a logic "0". A connection to signal ground shall indicate a logic "1". The discrete input circuitry shall require external drivers to source or sink no more than 2.0 milliamperes.

D.3.1.3 Data wrap-around. The DRUH RT shall implement a data wrap-around capability and shall use a data wrap-around receive and transmit sub-address of 30 (11110).

D.3.1.4 Mode commands. Receive and transmit sub-addresses 0 (00000) and 31 (11111) shall be used for mode commands in accordance with MIL-STD-1553.

The following mode codes shall be implemented and treated as legal commands:

- a. Mode code 00001, Synchronize (no data)
- b. Mode code 00010, Transmit Status Word
- c. Mode code 00011, Initiate Self-test
- d. Mode code 00100, Transmitter Shutdown
- e. Mode code 00101, Override Transmitter Shutdown
- f. Mode code 01000, Reset Remote Terminal
- g. Mode code 10001, Synchronize (with data)
- h. Mode code 10010, Transmit Last Command
- i. Mode code 10011, Transmit BIT Word

All remaining mode codes shall be treated as illegal commands.

D.3.1.5 Reset remote terminal. The DRUH RT shall implement the Reset Remote Terminal Command as specified in MIL-STD-1553 and shall complete the reset function within 5.0 milliseconds. While being reset, the DRUH RT shall not respond to messages sent to it on either bus.

D.3.1.6 Initiate self-test. The DRUH RT shall implement the Initiate Self-test Command in accordance with MIL-STD-1553 and shall have the test results available within 100.0 milliseconds. While in self-test, the DRUH RT shall respond by transmitting a status word with the busy bit set.

D.3.1.7 Status word. The DRUH RT shall be capable of responding with status information and shall implement the following status flags in accordance with MIL-STD-1553.

- a. Message Error, bit 9

- b. Broadcast Command Received, bit 15
- c. Busy, bit 16
- d. Subsystem Flag, bit 17
- e. Terminal Flag, bit 19
- f. Parity, bit 20

The following status flags shall not be implemented.

- a. Instrumentation, bit 10
- b. Service Request, bit 11
- c. Reserved Status, bits 12 through 14
- d. Dynamic Bus Control Acceptance, bit 18

D.3.1.8 Busy bit. The busy bit shall be implemented as specified in MIL-STD-1553 and returned only when the DRUH RT is performing self-test.

D.3.1.9 Terminal flag bit. A terminal flag bit shall be used which does not discriminate between the two channels of the dual standby-redundant DRUH RT.

D.3.1.10 Illegal commands. The DRUH RT shall recognize illegal commands and to respond to them in accordance with MIL-STD-1553.

D.3.1.11 Sample consistency. Messages transmitted over the 1553 data bus shall contain only mutually consistent samples of information. Any invalid data transmitted over the data bus shall be indicated as invalid within the same message the data appears.

D.3.1.12 Variable message blocks. The DRUH RT shall be capable of receiving a message of up to 32 words for any valid subaddress, provided the word count is valid and equal to or greater than the defined minimum word count.

The DRUH RT shall be capable of transmitting a subset of any message defined for it. These subsets shall consist of messages with word counts varying from one to 32. If the word count exceeds the maximum word count defined for the particular message, words beyond the maximum word count shall be zero filled.

D.3.2 1553 command and message data description. The requirements for data in 1553 commands and messages are set forth in tables. Each row specifies the requirements for a data field.

A data field shall occupy the word or words specified in the WORD(s) column. Unless otherwise specified, the field shall completely fill the word(s) specified in the WORD(s) column. (msh) means the most significant half of a word, (lsh), the least significant half. Specific bit positions within a word, required to define a data field (for example, discrete data type), are identified in the BIT column. Otherwise this column is blank.

The data format for the field is specified in the TYPE column and applies to the entire field, regardless of length. Available data types are listed in Table D-I.

TABLE D-I Data types.

TYPE	DESCRIPTION
ASCII	ASCII coded characters. Each character contains 8 bits.
dis	Discrete - Individual bit(s) having a value of 0 (reset) or 1 (set).
hex	Hexadecimal coded characters. Each character contains 4 bits.
sb	Signed Binary - The most significant bit represents the sign (0 = +, 1 = -). The rest of the field is Unsigned Binary.
ub	Unsigned Binary - The entire field is positive.
2b	Two's Complement Binary

The allowable range of values for a field is specified in the RANGE column. When only a single value is given, it is the only permissible value.

All numeric fields are scaled binary. The resolution of the least significant bit is specified in the RES. column.

The units applicable to both the range and resolution are specified in the UNITS column.

The data to be input or output in the field is identified in the DATA ELEMENT column. Data elements are defined either within the table or elsewhere in this specification.

D.3.2.1 Time tags. Output data blocks containing DRUH position, attitude, and attitude rate data shall contain relative time tags that are updated each time the data in the corresponding output buffers are refreshed. The time tag count shall be incremented every 64 microseconds. When the time tag count exceeds the field size, the value shall rollover to zero.

D.3.3 RS-422 command equivalence. Commands that input data or change modes may have different names or implementations on the 1553 and RS-422 host data interfaces. 1553 commands or sequences equivalent to the RS-422 commands are listed in Table D-II. Normally, only the RS-422 command names are used in this specification. Unless otherwise specified, equivalent 1553 data interface functionality shall be implemented for each RS-422 command.

D.3.4 STATUS and ALERT timing. For changes in STATUS DATA and ALERT DATA initiated by receipt of a command, the DRUH shall be able to transmit, on the 1553 bus, the changed state(s) of the applicable bit(s) within: 200 msec after receipt of the initiating command, for all bits specified to be changed in the RS-422 response message; and the specified RS-422 response time for all other bits.

TABLE D-II. RS-422/1553 host command equivalence.

RS-422 COMMAND	1553 EQUIVALENT
ACCEPT CONFIGURATION DATA	ACCEPT CONFIGURATION DATA command
ACCEPT POSITION	ACCEPT POSITION DATA command
ACCEPT POINTING DEVICE BORESIGHT	ACCEPT BORESIGHT DATA command with W1 set valid
ACCEPT VEHICLE BORESIGHT	ACCEPT BORESIGHT DATA command with W8 set valid
ACCEPT GEODETIC DATA	ACCEPT GEODETIC DATA command
ACCEPT USER DATUM	ACCEPT USER DATUM command
PASS GPS SETUP DATA	PASS GPS SETUP DATA command
PASS GPS DIFFERENTIAL CORRECTIONS	PASS GPS DIFFERENTIAL CORRECTIONS command
ACCEPT HOST STATUS	ACCEPT MISCELLANEOUS DATA command with desired Host Status Valid flags set and desired Host Status data
RETURN DATUM DATA	ACCEPT MISCELLANEOUS DATA command, with Requested Datum Valid = 1 and desired datum number, followed by DATUM DATA message request
RETURN NEXT GPS WARNING	ACCEPT MODE command, code = 21 (QUEUE NEXT GPS WARNING) followed by GPS WARNING message request
RESET DISTANCE	ACCEPT MODE command, code = 1
OVERRIDE ALERT	ACCEPT MODE command, code = 2
INHIBIT AUXILIARY BUS CONTROL	Not required
ENABLE AUXILIARY BUS CONTROL	Not required
INHIBIT ZERO-VELOCITY UPDATES	ACCEPT MODE command, code = 3
ENABLE ZERO-VELOCITY UPDATES	ACCEPT MODE command, code = 4
RESTART	ACCEPT MODE command, code = 5
STORED HEADING ALIGN	ACCEPT MODE command, code = 6
SHUTDOWN	ACCEPT MODE command, code = 7
INHIBIT ODOMETER REQUEST	ACCEPT MODE command, code = 8
ENABLE ODOMETER REQUEST	ACCEPT MODE command, code = 9
IN TRAVEL LOCK	ACCEPT MODE command, code = 10
OUT OF TRAVEL LOCK	ACCEPT MODE command, code = 11
STORED HEADING SHUTDOWN	ACCEPT MODE command, code = 12
AIR TRANSPORT MODE REQUEST	ACCEPT MODE command, code = 13
MARINE TRANSPORT MODE REQUEST	ACCEPT MODE command, code = 14
TRANSPORT MODE COMPLETE	ACCEPT MODE command, code = 15
ENABLE INERTIAL MODE	ACCEPT MODE command, code = 16
ENABLE INTEGRATED MODE	ACCEPT MODE command, code = 17
USE DEGRADED GPS DATA	ACCEPT MODE command, code = 18
SELECT Y-CODE ONLY SATELLITES	ACCEPT MODE command, code = 19
SELECT P OR Y-CODE SATELLITES	ACCEPT MODE command, code = 20
DO NOT APPLY RELATIVE OFFSETS	ACCEPT MODE command, code = 22
APPLY RELATIVE OFFSETS	ACCEPT MODE command, code = 23
RESET RELATIVE OFFSETS	ACCEPT MODE command, code = 24

D.3.5 1553 receive command messages. The receive commands and associated data words from the host that provide mode control of the DRUH or data transfer to the DRUH are summarized below. The DRUH shall be capable of receiving any combination of command messages listed in Table D-III, including data, at rates up to 5 commands per second.

TABLE D-III. Receive command messages.

SUBADDRESS	WORDS *	RECEIVE COMMAND MESSAGE
0	-	Reserved (MIL-STD-1553 Mode Control)
1	1	ACCEPT MODE
2	27	ACCEPT CONFIGURATION DATA
3	12	ACCEPT POSITION DATA
4	11	ACCEPT BORESIGHT DATA
5	12	ACCEPT GEODETIC DATA
6	20	ACCEPT USER DATUM
7	15	PASS GPS SETUP DATA
8	20	PASS GPS DIFFERENTIAL CORRECTION
9	4	ACCEPT MISCELLANEOUS DATA
10	-	Not Used (Host System Spare)
11	-	Not Used (Host System Spare)
12	-	Not Used (Host System Spare)
13	-	Not Used (Host System Spare)
14	-	Not Used (Host System Spare)
15	-	Not Used (Host System Spare)
16-29	-	Reserved (Vendor Unique Messages)
30	-	Reserved (MIL-STD-1553 Data Wrap)
31	-	Reserved (MIL-STD-1553 Mode Control)

\* The data word count listed is the minimum required for a valid message. An integrator may choose to send a valid message with a larger word count (up to 32 words).

D.3.5.1 ACCEPT MODE command.

Function: Requests the DRUH to make a mode or operation change.

<b>RECEIVE SUBADDRESS</b>	1	<b>DATA WORD COUNT</b>	1
---------------------------	---	------------------------	---

WORD(s)	BIT	TYPE	RANGE	RES.	UNITS	DATA ELEMENT
W1		ub	1 thru 24	1	n/a	Mode Command Code Number

Mode command code numbers and functions shall be as specified below. Mode command accept/reject criteria and responses are specified elsewhere in this document. The DRUH shall accept only one mode command code number per ACCEPT MODE command.

CODE	MODE COMMAND NAME	FUNCTION
1	RESET DISTANCE	Reset distance traveled to zero.
2	OVERRIDE ALERT	Reset overrideable ALERT DATA bits.
3	INHIBIT ZERO-VELOCITY UPDATES	Inhibit ZUPTs and ZUPT stop requests.
4	ENABLE ZERO-VELOCITY UPDATES	Enable ZUPTs and ZUPT stop requests.
5	RESTART	Initiate Restart.
6	STORED HEADING ALIGN	Initiate Accelerated Align.
7	SHUTDOWN	Initiate normal shutdown.
8	INHIBIT ODOMETER REQUEST	Inhibit use of VMS aiding and VMS test.
9	ENABLE ODOMETER REQUEST	Perform VMS test and enable use of VMS aiding.
10	IN TRAVEL LOCK	Host signal indicating DRUH is stowed for travel.
11	OUT OF TRAVEL LOCK	Host signal indicating DRUH is not stowed for travel.
12	STORED HEADING SHUTDOWN	Initiate Stored Heading shutdown.
13	AIR TRANSPORT MODE REQUEST	Initiate Air Transport operation.
14	MARINE TRANSPORT MODE REQUEST	Initiate Marine Transport operation.
15	TRANSPORT MODE COMPLETE	End transport mode operation.
16	ENABLE INERTIAL MODE	Inhibit GPS aiding.
17	ENABLE INTEGRATED MODE	Enable GPS aiding.
18	USE DEGRADED GPS DATA	Allow use of GPS data meeting the "poor" EPE criteria.
19	SELECT Y-CODE ONLY SATELLITES	Request the GPS receiver to use only Y-code satellites.
20	SELECT P OR Y-CODE SATELLITES	Request the GPS receiver to use mixed P and Y-code satellites.
21	QUEUE NEXT GPS WARNING	Load the next GPS warning message into the output buffer.
22	DO NOT APPLY RELATIVE OFFSETS	Output positions without relative offsets applied.
23	APPLY RELATIVE OFFSETS	Output positions with relative offsets applied.
24	RESET RELATIVE OFFSETS	Reset relative offsets to zero.

D.3.5.2 ACCEPT CONFIGURATION DATA command.

Function: Requests the DRUH to accept a configuration data update and tailor operation using the new configuration data. Configuration data elements are defined in Appendix C.

<b>RECEIVE SUBADDRESS</b>	2	<b>DATA WORD COUNT</b>	27
---------------------------	---	------------------------	----

WORD(s)	BIT	TYPE	RANGE	RES.	UNITS	DATA ELEMENT
W1		2b	0	1	n/a	Reserved Spare
W2		2b	-3199.9 to +3200.0	0.1	mil	1 - 2 Threshold Angle
W3		2b	-3199.9 to +3200.0	0.1	mil	2 - 1 Threshold Angle
W4		2b	-25.00 to +25.00	0.01	meter	Orientation 1 Vehicle ΔX
W5		2b	-25.00 to +25.00	0.01	meter	Orientation 1 Vehicle ΔY
W6		2b	-25.00 to +25.00	0.01	meter	Orientation 1 Vehicle ΔZ
W7		2b	-25.00 to +25.00	0.01	meter	Orientation 2 PD ΔX
W8		2b	-25.00 to +25.00	0.01	meter	Orientation 2 PD ΔY
W9		2b	-25.00 to +25.00	0.01	meter	Orientation 2 PD ΔZ
W10		ub	2 to 15	0.25	minute	Exclusive ZUPT mode ZUPT interval
W11		ub	2 to 63	1	minute	Odometer Mode ZUPT interval
W12		ub	3.5 to 34.0	0.25	minute	Static Align Time
W13		ub	0 to 10 (0 valid only if D29/5 is reset)	1	second	Shot Detect Interval
W14-W15		dis	n/a	n/a	n/a	Configuration definition flags (See Appendix C.)
W16		ub	0.750 to 1.250	0.001	n/a	Odometer Scale Factor
W17		2b	-3276.8 to +3276.7	0.1	μ-radian /km	Fuel Consumption Factor
W18 (msh)		hex	00 to 3F	n/a	n/a	DRUH Coordinate Frame Code for Orientation 1
W18 (lsh)		hex	00 to 3F	n/a	n/a	DRUH Coordinate Frame Code for Orientation 2
W19		2b	-25.00 to +25.00	0.01	meter	Odometer action point ΔX
W20		2b	-25.00 to +25.00	0.01	meter	Odometer action point ΔY
W21		2b	-25.00 to +25.00	0.01	meter	Odometer action point ΔZ
W22		2b	-25.00 to +25.00	0.01	meter	GPS antenna ΔX
W23		2b	-25.00 to +25.00	0.01	meter	GPS antenna ΔY
W24		2b	-25.00 to +25.00	0.01	meter	GPS antenna ΔZ
W25		ub	10 to 900	1	second	GPS Update Time-out Interval
W26		ub	0 to 256	1	meter	GPS EPE Good Value
W27		ub	0 to 32,535	1	meter	GPS EPE Poor Value

D.3.5.3 ACCEPT POSITION DATA command.

Function: Requests the DRUH to accept a grid coordinate position update.

<b>RECEIVE SUBADDRESS</b>	<b>3</b>	<b>DATA WORD COUNT</b>	<b>12</b>
---------------------------	----------	------------------------	-----------

WORD(s)	BIT	TYPE	RANGE	RES.	UNITS	DATA ELEMENT
W1, W2		ub	0 to 10,000,000	0.01	meter	Northing
W3, W4		ub	0 to 999,9999	0.01	meter	Easting
W5, W6		2b	-1,000 to +10,000	0.01	meter	Altitude
W7		2b	-61 to +61	1	n/a	Extended Zone Number + = northern hemisphere - = southern hemisphere (DRUH shall ignore sign) ±61 = Normal Zone
W8		2b	-60 to +60	1	n/a	Hemisphere & Zone of DRUH + = northern hemisphere - = southern hemisphere
W9	00 thru 10	dis	0	n/a	n/a	Spare Bits
W9	11	dis	0 or 1	n/a	n/a	Determine Relative Offsets flag
W9	12 thru 15	ub	0 to 1	1	n/a	Host (DRUH) Grid 0 = BNG 1 = UTM
W10-W12		ASCII	Valid Datum ID Codes (Appendix G)	n/a	n/a	Datum ID Code (6 ASCII Characters)

D.3.5.4 ACCEPT BORESIGHT DATA command.

Function: Requests the DRUH to accept a pointing device boresight angles and/or vehicle boresight angles update. Boresight angle parameters are defined in Appendix C.

The DRUH shall not validate or update pointing device boresight angles if W1 = 0. If W1 = 1, the DRUH shall update and use the new pointing device boresight angles if: the Pointing Device Boresight flag (CFIG D29/7) is set; the DRUH is stationary; and all pointing device boresight angles are within their allowable ranges. Otherwise, the DRUH shall not update pointing device boresight angles and shall set the appropriate rejection ALERT DATA bit(s).

The DRUH shall not update or check for acceptance vehicle boresight angles if W8 = 0. If W8 = 1, the DRUH shall update and use the new vehicle boresight angles if: the Vehicle Boresight flag (CFIG D29/6) is set; the DRUH is stationary; and all vehicle boresight angles are within their allowable ranges. Otherwise, the DRUH shall not update vehicle boresight angles and shall set the appropriate rejection ALERT DATA bit(s).

<b>RECEIVE SUBADDRESS</b>	4	<b>DATA WORD COUNT</b>	11
---------------------------	---	------------------------	----

WORD(s)	BIT	TYPE	RANGE	RES.	UNITS	DATA ELEMENT
W1		ub	0 to 1	1	n/a	Pointing Device Boresight Valid invalid = 0; valid = 1
W2		ub	0 to 6399.9	0.1	mil	Pointing Device Orient. 1 A
W3		2b	-1600.0 to +1600.0	0.1	mil	Pointing Device Orient. 1 B
W4		2b	-3199.9 to +3200.0	0.1	mil	Pointing Device Orient. 1 $\Gamma$
W5		ub	0 to 6399.9	0.1	mil	Pointing Device Orient. 2 A
W6		2b	-1600.0 to +1600.0	0.1	mil	Pointing Device Orient. 2 B
W7		2b	-3199.9 to 3200.0	0.1	mil	Pointing Device Orient. 1 $\Gamma$
W8		ub	0 to 1	1	n/a	Vehicle Boresight Valid invalid = 0; valid = 1
W9		ub	0 to 6399.9	0.1	mil	Vehicle $\alpha$
W10		2b	-1600.0 to +1600.0	0.1	mil	Vehicle $\beta$
W11		2b	-3199.9 to 3200.0	0.1	mil	Vehicle $\gamma$

D.3.5.5 ACCEPT GEODETIC DATA command.

Function: Requests the DRUH to accept a geodetic coordinate position update from the host.

<b>RECEIVE SUBADDRESS</b>	5	<b>DATA WORD COUNT</b>	12
---------------------------	---	------------------------	----

WORD(s)	BIT	TYPE	RANGE	RES.	UNITS	DATA ELEMENT
W1		sb	-90 to +90	1	degree	Latitude Degrees * + = Northern hemisphere - = Southern hemisphere
W2, W3		ub	0 to $(60 - 1/2^{24})$	$1/2^{24}$	arc minute	Latitude Minutes *
W4		sb	-180 to +180	1	degree	Longitude Degrees * + = East of Prime Meridian - = West of Prime Meridian
W5, W6		ub	0 to $(60 - 1/2^{24})$	$1/2^{24}$	arc minute	Longitude Minutes *
W7, W8		2b	-1,000 to +10,000	0.01	meter	Altitude
W9	00 thru 10	dis	0	n/a	n/a	Spare Bits
W9	11	dis	0 or 1	n/a	n/a	Determine Relative Offsets input flag
W9	12 thru 15	ub	0 to 1	1	n/a	Host (DRUH) Grid 0 = BNG 1 = UTM
W10-W12		ASCII	Valid Datum ID Codes (Appendix G)	n/a	n/a	Datum ID Code (6 ASCII Characters)

- \* In addition to the individual field range limits for degrees and minutes, the combination of degrees and minutes shall not exceed the degrees field range limits for latitude and longitude, respectively.

D.3.5.6 ACCEPT USER DATUM command.

Function: Requests the DRUH to retain the input data for use as USER1 or USER2 datum parameters, corresponding to the validity flag. Acceptance of this command shall not change the datum parameters currently used by the DRUH. (For the DRUH to use newly entered user datum parameters, the host must send a position update command containing the appropriate Datum ID.)

The user defined datum parameters are difference (delta) values (WGS 84 minus local datum).

<b>RECEIVE SUBADDRESS</b>	<b>6</b>	<b>DATA WORD COUNT</b>	<b>20</b>
---------------------------	----------	------------------------	-----------

WORD(s)	BIT	TYPE	RANGE	RES.	UNITS	DATA ELEMENT
W1-W3		ASCII	Valid Datum ID Code (Appendix G)	n/a	n/a	Datum ID Code
W4, W5		2b	±2000.000	0.001	meter	User datum delta-a *
W6, W7		2b	±2000.000	0.001	n/a	User datum delta-f x10E7 *
W8		2b	±2000.0	0.1	meter	User datum delta-x *
W9		2b	±2000.0	0.1	meter	User datum delta-y *
W10		2b	±2000.0	0.1	meter	User datum delta-z *
W11		ub	0 to 26	1	n/a	MGRS Row Advance *
W12-W19		ASCII	See Appendix G	n/a	n/a	Datum Descriptor
W20		ub	0 thru 2	1	n/a	User Datum Validity: 0 = data not valid, 1 = data valid, DRUH USER1 2 = data valid, DRUH USER2

- \* When the GPS Installed flag (CFIG D27/7) is set, the DRUH shall send these data elements to the GPS receiver via GPS message #5038 (User Datums). The GPS receiver range limits may differ from those of the DRUH. If so, data outside the GPS receiver range limits may cause ALERT D1/6 (Datums Do Not Agree) to occur.

D.3.5.7 PASS GPS SETUP DATA command.

Function: Requests the DRUH to send setup data to the GPS receiver via GPS Message #5030 (Setup Data). The DRUH maintains control of Code Type and Elevation Hold Type and may override data input in this command.

<b>RECEIVE SUBADDRESS</b>	7	<b>DATA WORD COUNT</b>	15
---------------------------	---	------------------------	----

WORD(s)	BIT	TYPE	RANGE	RES.	UNITS	DATA ELEMENT
W1	*	*	*	*	*	Validity (Word 5)
W2	*	*	*	*	*	Code Type (Word 6)
W3	*	*	*	*	*	Coordinate Reference (Word 7)
W4	*	*	*	*	*	Distance Units (Word 8)
W5	*	*	*	*	*	Elevation Units (Word 9)
W6	*	*	*	*	*	Elevation Reference (Word 10)
W7	*	*	*	*	*	Angular Units (Word 11)
W8	*	*	*	*	*	North Reference (Word 12)
W9	*	*	*	*	*	MVAR Type (Word 13)
W10	*	*	*	*	*	Entered MVAR (Word 14)
W11	*	*	*	*	*	Entered MVAR (Word 15)
W12	*	*	*	*	*	Navigation Type (Word 16)
W13	*	*	*	*	*	Elevation Hold Type (Word 17)
W14	*	*	*	*	*	Time Reference (Word 18)
W15	*	*	*	*	*	Error Units (Word 19)

- \* Shall be as specified in ICD-GPS-153 for message #5030 (Setup Data) for the data elements and words listed in the DATA ELEMENT column.

D.3.5.8 PASS GPS DIFFERENTIAL CORRECTIONS command.

Function: Requests the DRUH to send Differential GPS (DGPS) corrections to the GPS receiver via GPS Message #260 (Differential Corrections).

<b>RECEIVE SUBADDRESS</b>	8	<b>DATA WORD COUNT</b>	20
---------------------------	---	------------------------	----

WORD(s)	BIT	TYPE	RANGE	RES.	UNITS	DATA ELEMENT
W1	*	*	*	*	*	Bytes 1 and 2 of data (Word 1)
W2	*	*	*	*	*	Bytes 3 and 4 of data (Word 2)
W3	*	*	*	*	*	Bytes 5 and 6 of data (Word 3)
W4	*	*	*	*	*	Bytes 7 and 8 of data (Word 4)
W5	*	*	*	*	*	Bytes 9 and 10 of data (Word 5)
W6	*	*	*	*	*	Bytes 11 and 12 of data (Word 6)
W7	*	*	*	*	*	Bytes 13 and 14 of data (Word 7)
W8	*	*	*	*	*	Bytes 15 and 16 of data (Word 8)
W9	*	*	*	*	*	Bytes 17 and 18 of data (Word 9)
W10	*	*	*	*	*	Bytes 19 and 20 of data (Word 10)
W11	*	*	*	*	*	Bytes 21 and 22 of data (Word 11)
W12	*	*	*	*	*	Bytes 23 and 24 of data (Word 12)
W13	*	*	*	*	*	Bytes 25 and 26 of data (Word 13)
W14	*	*	*	*	*	Bytes 27 and 28 of data (Word 14)
W15	*	*	*	*	*	Bytes 29 and 30 of data (Word 15)
W16	*	*	*	*	*	Bytes 31 and 32 of data (Word 16)
W17	*	*	*	*	*	Bytes 33 and 34 of data (Word 17)
W18	*	*	*	*	*	Bytes 35 and 36 of data (Word 18)
W19	*	*	*	*	*	Bytes 37 and 38 of data (Word 19)
W20	*	*	*	*	*	Bytes 39 and 40 of data (Word 20)

\* Shall be as specified in ICD-GPS-153 for GPS message #260 (Differential Corrections) for the data elements and words listed in the DATA ELEMENT column.

**NOTE:** More than one PASS GPS DIFFERENTIAL CORRECTIONS command may be required to transmit an entire RTCM DGPS data set to the DRUH and GPS receiver. Unused bytes following the last DGPS data byte in this command should be filled with "00000000".

D.3.5.9 ACCEPT MISCELLANEOUS DATA command.

Function: Requests the DRUH to accept miscellaneous data, including Host Status and Requested Datum Number.

The DRUH shall set STATUS DATA S5/1 (Host Status A) and/or S5/0 (Host Status B) to the state(s) input in an ACCEPT MISCELLANEOUS DATA command containing valid Host Status data.

The DRUH shall queue data, for the requested datum number, for output in a DATUM DATA BLOCK, within 100 milliseconds after receipt of an ACCEPT MISCELLANEOUS DATA command containing a valid datum number. The DRUH shall reject an out of range datum number and set ALERT DATA D5/2 (Invalid Data Received).

<b>RECEIVE SUBADDRESS</b>	9	<b>DATA WORD COUNT</b>	4
---------------------------	---	------------------------	---

WORD(s)	BIT	TYPE	RANGE	RES.	UNITS	DATA ELEMENT
W1	00 thru 12	dis	0	n/a	n/a	Spare bits
W1	13	dis	0 or 1	n/a	n/a	Datum Number Valid flag
W1	14	dis	0 or 1	n/a	n/a	Host Status B Valid flag
W1	15	dis	0 or 1	n/a	n/a	Host Status A Valid flag
W2		ub	0 to 1	1	n/a	Host A Status (0 = reset, 1 = set) (Valid only when W1/15 = 1)
W3		ub	0 to 1	1	n/a	Host B Status (0 = reset, 1 = set) (Valid only when W1/ 14 = 1)
W4		ub	0 thru 64	1	n/a	Requested Datum Number; 0 = Datum In Use 1 thru 60 = DRUH preprogrammed Datums 61 = DRUH USER1 Datum 62 = DRUH USER2 Datum 63 = GPS USER1 Datum 64 = GPS USER2 Datum (Valid only when W1/13 = 1)

D.3.6 1553 transmit command messages. The DRUH shall transmit data to the host via the transmit command messages listed in Table D-IV.

TABLE D-IV. Transmit command messages.

SUBADDRESS	WORDS *	TRANSMIT COMMAND MESSAGE
0	-	Reserved (MIL-STD-1553 Mode Control)
1	26	ATTITUDE DATA BLOCK
2	28	GRID POSITION DATA BLOCK
3	29	GEODETTIC POSITION DATA BLOCK
4	27	CONFIGURATION DATA
5	9	BORESIGHT DATA BLOCK
6	10	SURVEY QUALITY
7	20	DATUM DATA
8	12	GPS TIME & DAY
9	32	GPS POSITION DATA
10	21	GPS WARNING
11	19	DRUH S/W IDENTIFICATION DATA
12	-	Not Used (Host System Spare)
13	-	Not Used (Host System Spare)
14	-	Not Used (Host System Spare)
15	-	Not Used (Host System Spare)
16-29	-	Reserved (Vendor Unique Messages)
30	-	Reserved (MIL-STD-1553 Data Wrap)
31	-	Reserved (MIL-STD-1553 Mode Control)

\* The data word count listed is the number of words needed to transmit the complete message. An integrator may choose to request a message with word counts varying from one to 32 words.

When a valid transmit message request is received, the DRUH shall transmit the requested message containing the data elements specified in the following subparagraphs. Data elements shall be refreshed at the rates specified or higher.

D.3.6.1 ATTITUDE DATA BLOCK message.

Function: Provides Pointing Device attitudes and attitude rates, Vehicle attitudes, Travel Lock Reference attitudes, STATUS DATA, ALERT DATA, and BIT DATA.

<b>TRANSMIT SUBADDRESS</b>	1	<b>DATA WORD COUNT</b>	26
----------------------------	---	------------------------	----

Refresh Rate: W1-W17, 100 Hz minimum; W18-W26, 5 Hz minimum.

WORD(s)	BIT	TYPE	RANGE	RES.	UNITS	DESCRIPTION
W1-W3		dis	n/a	n/a	n/a	STATUS DATA (Appendix B)
W4-W6		dis	n/a	n/a	n/a	ALERT DATA (Appendix B)
W7		dis	n/a	n/a	n/a	BIT DATA (Appendix B)
W8		ub	0 to +4,194,240	64	μ-second	Pointing Device Attitude Time Tag
W9, W10		ub	0 to 6,399.99	0.01	mil	Pointing Device Geodetic Azimuth or Grid Azimuth
W11, W12		2b	-1600.00 to +1600.00	0.01	mil	Pointing Device Pitch
W13, W14		2b	-3199.99 to +3200.00	0.01	mil	Pointing Device Roll or Cant
W15		2b	-5898.24 to +5898.06 *	0.18	mil/sec	Pointing Device Azimuth Rate
W16		2b	-5898.24 to +5898.06 *	0.18	mil/sec	Pointing Device Pitch Rate
W17		2b	-5898.24 to +5898.06 *	0.18	mil/sec	Pointing Device Roll Rate
W18		ub	0 to +4,194,240	64	μ-second	Vehicle Attitude Time Tag
W19, W20		ub	0 to 6,399.99	0.01	mil	Vehicle Geodetic or Grid Azimuth
W21, W22		2b	-1600.00 to +1600.00	0.01	mil	Vehicle Pitch
W23, W24		2b	-3199.99 to +3200.00	0.01	mil	Vehicle Roll or Cant
W25		ub	0 to 6,399.9	0.1	mil	Travel Lock Pointing Device Geodetic or Grid Azimuth Reference
W26		2b	-1600 to +1600	0.1	mil	Travel Lock Pointing Device Pitch Reference

\* For values outside the range, the output value shall be fixed at the appropriate positive or negative range limit.

D.3.6.2 GRID POSITION DATA BLOCK message.

Function: Provides grid position, altitude, velocity, STATUS DATA, ALERT DATA, BIT DATA, and Align Time To Go.

<b>TRANSMIT SUBADDRESS</b>	2	<b>DATA WORD COUNT</b>	28
----------------------------	---	------------------------	----

Refresh Rate: W1-W28, 5 Hz minimum.

WORD(s)	BIT	TYPE	RANGE	RES.	UNITS	DATA ELEMENT
W1-W3		dis	n/a	n/a	n/a	STATUS DATA (Appendix B)
W4-W6		dis	n/a	n/a	n/a	ALERT DATA (Appendix B)
W7		dis	n/a	n/a	n/a	BIT DATA (Appendix B)
W8		ub	0 to 2047	1	second	Align Time To Go
W9 (msh)		2b	0	1	n/a	Reserved spare
W9 (lsh)		2b	-60 to +60	1	n/a	DRUH Hemisphere & Zone + = northern hemisphere - = southern hemisphere
W10, W11		ub	0 to 999,999 *	0.01	meter	Easting
W12, W13		ub	0 to 10,000,000	0.01	meter	Northing
W14, W15		2b	-32,768 to +32,767	0.01	meter	Altitude
W16, W17		2b	-32,768 to +32,767	1/2 <sup>16</sup>	meter/sec	Velocity North
W18, W19		2b	-32,768 to +32,767	1/2 <sup>16</sup>	meter/sec	Velocity East
W20, W21		2b	-32,768 to +32,767	1/2 <sup>16</sup>	meter/sec	Velocity Up
W22	00 thru 10	dis	0	n/a	n/a	Spare Bits
W22	11	dis	0 or 1	n/a	n/a	Relative Offsets Applied output flag
W22	12 thru 15	ub	0 to 1	1	n/a	Host (DRUH) Grid 0 = BNG 1 = UTM
W23-W25		ASCII	Valid Datum ID Codes (Appendix G)	n/a	n/a	Datum ID Code
W26, W27		ub	0 to 1,310,710 **	10	meter	Distance Traveled ***
W28		ub	0 to +4,194,240	64	μ-second	Position Time Tag

\* Actual limits are the UTM zone boundaries plus zone extension, which are latitude and datum dependent.

\*\* For values outside the range, the output value shall be fixed at the appropriate positive or negative range limit.

\*\*\* Total distance traveled since turn-on or last RESET DISTANCE command. Distance Traveled may not accurately reflect the actual vehicle trajectory during Dynamic Align.

D.3.6.3 GEODETIC POSITION DATA BLOCK message.

Function: Provides geodetic position, altitude, velocity, STATUS DATA, ALERT DATA, BIT DATA, and Align Time To Go.

<b>TRANSMIT SUBADDRESS</b>	3	<b>DATA WORD COUNT</b>	29
----------------------------	---	------------------------	----

Refresh Rate: W1-W29, 5 Hz minimum.

WORD(s)	BIT	TYPE	RANGE	RES.	UNITS	DESCRIPTION
W1-W3		dis	n/a	n/a	n/a	STATUS DATA (Appendix B)
W4-W6		dis	n/a	n/a	n/a	ALERT DATA (Appendix B)
W7		dis	n/a	n/a	n/a	BIT DATA (Appendix B)
W8		ub	0 to 2047	1	second	Align Time To Go
W9		sb	-90 to +90	1	degree	Latitude Degrees * + = Northern hemisphere - = Southern hemisphere
W10, W11		ub	0 to (60 - 1/2 <sup>24</sup> )	1/2 <sup>24</sup>	arc minute	Latitude Minutes *
W12		sb	-180 to +180	1	degree	Longitude Degrees * + = East of Prime Meridian - = West of Prime Meridian
W13, W14		ub	0 to (60 - 1/2 <sup>24</sup> )	1/2 <sup>24</sup>	arc minute	Longitude Minutes *
W15, W16		2b	-32,768 to +32,767	0.01	meter	Altitude
W17, W18		2b	-32,768 to +32,767	1/2 <sup>16</sup>	meter /sec	Velocity North
W19, W20		2b	-32,768 to +32,767	1/2 <sup>16</sup>	meter /sec	Velocity East
W21, W22		2b	-32,768 to +32,767	1/2 <sup>16</sup>	meter /sec	Velocity Up
W23	00 thru 10	dis	0	n/a	n/a	Spare Bits
W23	11	dis	0 or 1	n/a	n/a	Relative Offsets Applied output flag
W23	12 thru 15	ub	0 to 1	1	n/a	Host (DRUH) Grid 0 = BNG 1 = UTM
W24-W26		ASCII	Valid Datum ID Codes (Appendix G)	n/a	n/a	Datum ID Code
W27, W28		ub	0 to 1,310,710 **	10	meter	Distance Traveled ***
W29		ub	0 to +4,194,240	64	μ- second	Position Time Tag

\* In addition to the individual field range limits for degrees and seconds, the combination of degrees and minutes must not exceed the degrees field range limit for latitude and longitude, respectively.

\*\* If the actual value of the parameter is outside the range, the output value shall be fixed at the appropriate positive or negative range limit.

\*\*\* Total distance traveled since turn-on or last RESET DISTANCE command. Distance Traveled may not accurately reflect the actual vehicle trajectory during Dynamic Align.

D.3.6.4 CONFIGURATION DATA BLOCK message.

Function: Provides the configuration data presently used by the DRUH. If the Configuration Data Present flag is reset, the data returned in a CONFIGURATION DATA BLOCK message may be invalid. Configuration data elements are defined in Appendix C.

<b>TRANSMIT SUBADDRESS</b>	4	<b>DATA WORD COUNT</b>	27
----------------------------	---	------------------------	----

Refresh Rate: W1-W27, as required; upon DRUH initialization or acceptance of ACCEPT CONFIGURATION DATA command.

WORD(s)	BIT	TYPE	RANGE	RES.	UNITS	DATA ELEMENT
W1		ub	0 thru 15	1	n/a	Current Configuration Code Number
W2		2b	-3199.9 to +3200.0	0.1	mil	1 - 2 Threshold Angle
W3		2b	-3199.9 to +3200.0	0.1	mil	2 - 1 Threshold Angle
W4		2b	-25.00 to +25.00	0.01	meter	Orientation 1 Vehicle ΔX
W5		2b	-25.00 to +25.00	0.01	meter	Orientation 1 Vehicle ΔY
W6		2b	-25.00 to +25.00	0.01	meter	Orientation 1 Vehicle ΔZ
W7		2b	-25.00 to +25.00	0.01	meter	Orientation 2 PD ΔX
W8		2b	-25.00 to +25.00	0.01	meter	Orientation 2 PD ΔY
W9		2b	-25.00 to +25.00	0.01	meter	Orientation 2 PD ΔZ
W10		ub	2 to 15	.25	minute	Exclusive ZUPT mode ZUPT interval
W11		ub	2 to 63	1	minute	Odometer Mode ZUPT interval
W12		ub	3.5 to 34.0	0.25	minute	Static Align Time
W13		ub	0 to 10 (0 valid only if D29/5 is reset)	1	second	Shot Detect Interval
W14-W15		dis	n/a	n/a	n/a	Configuration definition flags
W16		ub	0.750 to 1.250	0.001	n/a	Odometer Scale Factor
W17		2b	-3276.8 to +3276.7	0.1	μ-radian /km	Fuel Consumption Factor
W18 (msh)		hex	00 to 3F	n/a	n/a	DRUH Coordinate Frame Code for Orientation 1
W18 (lsh)		hex	00 to 3F	n/a	n/a	DRUH Coordinate Frame Code for Orientation 2
W19		2b	-25.00 to +25.00	0.01	meter	Odometer action point ΔX
W20		2b	-25.00 to +25.00	0.01	meter	Odometer action point ΔY
W21		2b	-25.00 to +25.00	0.01	meter	Odometer action point ΔZ
W22		2b	-25.00 to +25.00	0.01	meter	GPS antenna ΔX
W23		2b	-25.00 to +25.00	0.01	meter	GPS antenna ΔY
W24		2b	-25.00 to +25.00	0.01	meter	GPS antenna ΔZ
W25		ub	10 to 900	1	second	GPS Update Time-out Interval
W26		ub	0 to 256	1	meter	GPS EPE Good Value
W27		ub	0 to 32,535	1	meter	GPS EPE Poor Value

D.3.6.5 BORESIGHT DATA BLOCK message.

Function: Provides the pointing device and vehicle boresight angle values currently used by the DRUH. Boresight angles are defined in Appendix C.

<b>TRANSMIT SUBADDRESS</b>	5	<b>DATA WORD COUNT</b>	9
----------------------------	---	------------------------	---

Refresh Rate: W1-W9, as required; upon DRUH initialization or acceptance of ACCEPT CONFIGURATION DATA, ACCEPT BORESIGHT DATA, ACCEPT POINTING DEVICE BORESIGHT, or ACCEPT VEHICLE BORESIGHT commands.

WORD(s)	BIT	TYPE	RANGE	RES.	UNITS	DATA ELEMENT
W1		ub	0 to 6399.9	0.1	mil	Pointing Device Orient. 1 A *
W2		2b	-1600.0 to +1600.0	0.1	mil	Pointing Device Orient. 1 B *
W3		2b	-3199.9 to +3200.0	0.1	mil	Pointing Device Orient. 1 $\Gamma$ *
W4		ub	0 to 6399.9	0.1	mil	Pointing Device Orient. 2 A *
W5		2b	-1600.0 to +1600.0	0.1	mil	Pointing Device Orient. 2 B *
W6		2b	-3199.9 to +3200.0	0.1	mil	Pointing Device Orient. 2 $\Gamma$ *
W7		ub	0 to 6399.9	0.1	mil	Vehicle $\alpha$ **
W8		2b	-1600.0 to +1600.0	0.1	mil	Vehicle $\beta$ **
W9		2b	-3199.9 to +3200.0	0.1	mil	Vehicle $\gamma$ **

\* If the Pointing Device Boresight Present Flag is reset, pointing device boresight angles may be invalid.

\*\* If the Vehicle Boresight Present flag is reset, vehicle boresight angles may be invalid.

D.3.6.6 SURVEY QUALITY message.

Function: Provides the values of relative offsets and current DRUH estimates of DRUH position and azimuth errors.

<b>TRANSMIT SUBADDRESS</b>	6	<b>DATA WORD COUNT</b>	10
----------------------------	---	------------------------	----

Refresh Rate: W1-W7, 5 Hz minimum. W8-W10, as required; upon DRUH initialization, acceptance of a position update with the Determine Relative Offsets flag set, or acceptance of a RESET RELATIVE OFFSETS command.

WORD(s)	BIT	TYPE	RANGE	RES.	UNITS	DATA ELEMENT
W1		ub	0 to 2047	0.0625	meter	DRUH Estimated Horizontal CEP
W2		ub	0 to 2047	0.0625	meters	DRUH Estimated Vertical Probable Error
W3		ub	0 to 2047	0.0625	meter	DRUH Estimated Heading Probable Error
W4		ub	0 to 2047	0.0625	meter	Odometer Damped Horizontal CEP Specification (0.25% x distance traveled since last position update)
W5		ub	0 to 2047	0.0625	meter	Odometer Damped Vertical Probable Error Specification (0.067% x distance traveled since last altitude update)
W6		ub	0.1 to 10.0	0.0625	n/a	Estimated Horizontal Spec Multiplier
W7		ub	0.1 to 10.0	0.0625	n/a	Estimated Vertical Spec Multiplier
W8		2b	±2000.0	0.1	meter	North Relative Offset
W9		2b	±2000.0	0.1	meter	East Relative Offset
W10		2b	±2000.0	0.1	meter	Altitude Relative Offset

D.3.6.7 DATUM DATA message.

Function: Provides datum data for a previously requested datum number. If a datum number wasn't previously requested, data for the datum in use shall be output. Update of datums #63 and #64 may require up to two seconds following an ACCEPT USER DATUM command. Datum data elements are defined in Appendix G.

<b>TRANSMIT SUBADDRESS</b>	7	<b>DATA WORD COUNT</b>	20
----------------------------	---	------------------------	----

Refresh Rate: W1-W20, as required; upon DRUH initialization or acceptance of ACCEPT USER DATUM, ACCEPT MISCELLANEOUS DATA, ACCEPT POSITION DATA or ACCEPT GEODETIC DATA commands.

WORD(s)	BIT	TYPE	RANGE	RES.	UNITS	DESCRIPTION
W1 (msh)		ub	1 to 64	1	n/a	Reference Number for DRUH datum in use
W1 (lsh)		ub	0 to 64	1	n/a	Requested Datum Reference Number
W2-W4		ASCII	Valid Datum ID Code (Appendix G)	n/a	n/a	Datum ID Code
W5, W6		2b	±2000.000	0.001	meter	Datum delta-a
W7, W8		2b	±2000.000	0.001	n/a	Datum delta-f x10E7
W9		2b	±2000.0	0.1	meter	Datum delta-x
W10		2b	±2000.0	0.1	meter	Datum delta-y
W11		2b	±2000.0	0.1	meter	Datum delta-z
W12		ub	0 to 26	1	n/a	MGRS Row Advance
W13-W20		ASCII	See Appendix G	n/a	n/a	Datum Descriptor

D.3.6.8 GPS TIME & DAY message.

Function: Passes time and day data provided to the DRUH in GPS message #5040 (Current Status). The time represented is the time of validity of the last time mark message. If GPS message #5040 has never been received or has not been refreshed within two seconds of its previous reception, or if the GPS receiver has failed; GPS Time shall be set to 0 and other data elements may be outside the specified limits.

<b>TRANSMIT SUBADDRESS</b>	8	<b>DATA WORD COUNT</b>	12
----------------------------	---	------------------------	----

Refresh Rate: W1-W12, 1 Hz minimum.

WORD(s)	BIT	TYPE	RANGE	RES.	UNITS	DATA ELEMENT
W1	*	*	*	*	*	GPS Time (Word 1)
W2	*	*	*	*	*	GPS Time (Word 2)
W3	*	*	*	*	*	GPS Time (Word 3)
W4	*	*	*	*	*	GPS Time (Word 4)
W5	*	*	*	*	*	Time Reference (Word 19)
W6	*	*	*	*	*	Hours (Word 20)
W7	*	*	*	*	*	Minutes (Word 21)
W8	*	*	*	*	*	Seconds (Word 22)
W9	*	*	*	*	*	Day of Week (Word 23)
W10	*	*	*	*	*	Day of Month (Word 24)
W11	*	*	*	*	*	Month (Word 25)
W12	*	*	*	*	*	Year (Word 26)

- \* Shall be as specified in ICD-GPS-153 for the GPS message #5040 (Current Status) data elements and words specified in the DATA ELEMENT column.

D.3.6.9 GPS POSITION DATA message.

Function: Passes GPS receiver derived antenna position and status indicators of position accuracy provided to the DRUH in GPS message #5040 (Current Status). If GPS message #5040 has never been received or has not been refreshed within two seconds of its previous reception, or if the GPS receiver has failed; GPS Time shall be set to 0 and other data elements may be outside the specified limits.

<b>TRANSMIT SUBADDRESS</b>	9	<b>DATA WORD COUNT</b>	32
----------------------------	---	------------------------	----

Refresh Rate: W1-W32, 1 Hz minimum.

WORD(s)	BIT	TYPE	RANGE	RES.	UNITS	DATA ELEMENT
W1	*	*	*	*	*	GPS Time (Word 1)
W2	*	*	*	*	*	GPS Time (Word 2)
W3	*	*	*	*	*	GPS Time (Word 3)
W4	*	*	*	*	*	GPS Time (Word 4)
W5	*	*	*	*	*	Position (Word 5)
W6	*	*	*	*	*	Position (Word 6)
W7	*	*	*	*	*	Position (Word 7)
W8	*	*	*	*	*	Position (Word 8)
W9	*	*	*	*	*	Position (Word 9)
W10	*	*	*	*	*	Position (Word 10)
W11	*	*	*	*	*	Position (Word 11)
W12	*	*	*	*	*	Position (Word 12)
W13	*	*	*	*	*	Position (Word 13)
W14	*	*	*	*	*	Position (Word 14)
W15	*	*	*	*	*	Position (Word 15)
W16	*	*	*	*	*	Position (Word 16)
W17	*	*	*	*	*	Position (Word 17)
W18	*	*	*	*	*	Position (Word 18)
W19	*	*	*	*	*	FOM (Word 35)
W20	*	*	*	*	*	TFOM (Word 36)
W21	*	*	*	*	*	EPE (Word 40)
W22	*	*	*	*	*	EPE (Word 41)
W23	*	*	*	*	*	EPE Units (Word 42)
W24	*	*	*	*	*	Nav Converge (Word 43)
W25	*	*	*	*	*	Elevation Status (Word 44)
W26	*	*	*	*	*	Current DOP (Word 45)
W27	*	*	*	*	*	Current DOP (Word 46)
W28	*	*	*	*	*	Datum Identifier (Word 86)
W29	*	*	*	*	*	Datum Identifier (Word 87)
W30	*	*	*	*	*	Datum Identifier (Word 88)
W31	*	*	*	*	*	SA/A-S Message (Word 78)
W32		ub	0	1	n/a	Spare (set to 0)

- \* Shall be as specified in ICD-GPS-153 for the GPS message #5040 (Current Status) data elements and words specified in the DATA ELEMENT column.

D.3.6.10 GPS WARNING message.

Function: Provides GPS message #5044 (Warning Messages) ASCII character strings output by the GPS receiver and queued by the DRUH. When no GPS Warning Messages have been queued, or when all the messages have been deleted, the DRUH shall return: GPS Time = 0; Warning ID = 0; and Warning Message, (W6-W9) = "No PLGR "; (W10-W13) = " "; (W14-W17) = "Warnings"; (W18-W21) = " ".

The currently queued warning shall be returned in response to a transmit GPS WARNING command. The currently queued warning shall be deleted and the next stored warning shall be available for transmission within 100 milliseconds in response to a QUEUE NEXT GPS WARNING command.

<b>TRANSMIT SUBADDRESS</b>	10	<b>DATA WORD COUNT</b>	21
----------------------------	----	------------------------	----

Refresh Rate: W1-W21, as required; upon DRUH initialization or receipt of GPS message #5044 (Warning Messages) or acceptance of a QUEUE NEXT GPS WARNING command.

WORD(s)	BIT	TYPE	RANGE	RES.	UNITS	DATA ELEMENT
W1	*	*	*	*	*	GPS Time (Word 1)
W2	*	*	*	*	*	GPS Time (Word 2)
W3	*	*	*	*	*	GPS Time (Word 3)
W4	*	*	*	*	*	GPS Time (Word 4)
W5	*	*	*	*	*	Warning ID (Word 5)
W6	*	*	*	*	*	Warning Message (Word 6)
W7	*	*	*	*	*	Warning Message (Word 7)
W8	*	*	*	*	*	Warning Message (Word 8)
W9	*	*	*	*	*	Warning Message (Word 9)
W10	*	*	*	*	*	Warning Message (Word 10)
W11	*	*	*	*	*	Warning Message (Word 11)
W12	*	*	*	*	*	Warning Message (Word 12)
W13	*	*	*	*	*	Warning Message (Word 13)
W14	*	*	*	*	*	Warning Message (Word 14)
W15	*	*	*	*	*	Warning Message (Word 15)
W16	*	*	*	*	*	Warning Message (Word 16)
W17	*	*	*	*	*	Warning Message (Word 17)
W18	*	*	*	*	*	Warning Message (Word 18)
W19	*	*	*	*	*	Warning Message (Word 19)
W20	*	*	*	*	*	Warning Message (Word 20)
W21	*	*	*	*	*	Warning Message (Word 21)

- \* Shall be as specified in ICD-GPS-153 for the GPS message #5044 (Warning Messages) data elements and words specified in the DATA ELEMENT column.

D.3.6.11 DRUH S/W IDENTIFICATION DATA message.

Function: Provides the ID and revision numbers for the seven CSCIs of the DRUH, the DRUH S/N, and the GPS receiver hardware and software version numbers.

<b>TRANSMIT SUBADDRESS</b>	11	<b>DATA WORD COUNT</b>	32
----------------------------	----	------------------------	----

Refresh Rate: W1-W32, as required; upon DRUH initialization.

WORD(s)	BIT	TYPE	RANGE	RES.	UNITS	DESCRIPTION
W1, W2		ub	0 to 4,294,967,295	1	N/A	ID Number, DRUH Navigation Processor
W3, W4		ub	0 to 4,294,967,295	1	N/A	ID Number, Sensor Processor
W5, W6		ub	0 to 4,294,967,295	1	N/A	ID Number, DRUH Permanently Stored Configuration Data
W7, W8		ub	0 to 4,294,967,295	1	N/A	ID Number, DRUH Permanently Stored Datum Data
W9, W10		ub	0 to 4,294,967,295	1	N/A	ID Number, Bootstrap Loader
W11		ub	0 to 65,535	1	N/A	Rev. Number, DRUH Nav. Processor
W12		ub	0 to 65,535	1	N/A	Rev. Number, DRUH Sensor Processor
W13		ub	0 to 65,535	1	N/A	Rev. Number, DRUH Config. Data
W14		ub	0 to 65,535	1	N/A	Rev. Number, DRUH Datum Data
W15		ub	0 to 65,535	1	N/A	Rev. Number, Bootstrap Loader
W16		ub	0 to 65,535	1	N/A	DRUH Serial Number (Customer)
W17		ub	0 to 65,535	1	N/A	DRUH Serial Number (Vendor)
W18		2b	-32,768 to + 32,767	1	N/A	GPS receiver software version from GPS message #5040 (Word 48)
W19		2b	-32,768 to + 32,767	1	N/A	GPS receiver hardware version from GPS message #5040 (Word 49)
W20		ASCII	(A-Z, a-z, 0-9, -, space)	N/A	N/A	Loader Revision ID (2 ASCII Characters)
W21 - W23 (msh)		ASCII	(A-Z, a-z, 0-9, -, space)	N/A	N/A	DRUH Software Version ID (5 ASCII Characters)
W23 (lsh) - W28		ASCII	Note 1	N/A	N/A	DRUH Software Build Date (11 ASCII Characters)
W29 - W32		ASCII	Note 2	N/A	N/A	DRUH Software Build Time (8 ASCII Characters)

Note 1: 11 ASCII characters shall be formatted as MMM/DD/YYYY, where:

MMM is the month code, for the build month, per Note 3  
 DD is the build day of the month (range: 01-31)  
 YYYY is the build year (for example, 1996)  
 / is the ASCII / character

Note 2: 8 ASCII characters shall be formatted as hh:mm:ss, where:

hh is the build hour (range: 00 - 23)  
 mm is the build minute (range: 00 - 59)  
 ss is the build second (range: 00 - 59)  
 : is the ASCII : character

Note 3: Month Code/Month

JAN	January
FEB	February
MAR	March
APR	April
MAY	May
JUN	June
JUL	July
AUG	August
SEP	September
OCT	October
NOV	November
DEC	December

## APPENDIX E

## SHOCK AND VIBRATION TEST PROFILES

## E.1. SCOPE

E.1.1 Scope. This appendix provides vibration and gun fire shock profiles for use in vibration and reliability testing of the DRUH. This appendix is a mandatory part of this specification. The information herein is intended for compliance.

## E.2. APPLICABLE DOCUMENTS

(This section is not applicable to this appendix.)

## E.3. REQUIREMENTS

E.3.1 Vibration test profiles. Vibration test random-on-random vibration profiles are listed in Tables E-I, E-II and E-III for the vertical, transverse and longitudinal axes, respectively. The frequency and power spectral density (PSD) for each breakpoint are tabulated in the FREQ and PSD columns, respectively. The PSD shall be constant between breakpoints. No vibration excitation is required below 5 Hz or above 500 Hz. There are five profiles per axis. The DRUH shall be subjected to 54 minutes of vibration for each vibration profile. The total vibration time for each axis shall be 270 minutes. The total vibration time for the three axes shall be 810 minutes.

E.3.2 Reliability test vibration profiles. Reliability test random-on-random vibration profiles (M109A6) are listed in Tables E-IV and E-V for the vertical and longitudinal axes, respectively. The frequency and power spectral density (PSD) for each breakpoint are tabulated in the FREQ and PSD columns, respectively. The PSD shall be constant between breakpoints. No vibration excitation is required below 5 Hz or above 500 Hz. There are five profiles per axis.

Reliability test random vibration profiles (CUCV) are listed in Table E-VI for the vertical and longitudinal axes. The frequency and power spectral density (PSD) for each breakpoint are tabulated in the FREQ and PSD columns, respectively. The PSD shall vary linearly, on a log-log scale, between breakpoints. No vibration excitation is required below 5 Hz or above 500 Hz.

The DRUH shall be vibrated for equal amounts of time in the vertical and longitudinal axes. In each axis, the DRUH shall be vibrated for 50 percent of the time using the CUCV profile and 10 percent of the time using each of the five M109A6 profiles.

E.3.3 Gun fire shock profiles. Simulated gun fire shock profiles are shown in Figures E-1, E-2 and E-3 for the vertical, transverse and longitudinal axes, respectively. The DRUH shall be subjected to equal numbers of simulated gun shocks in each of the three axes.

E.3.3.1 Gun fire shock tolerances. Acceleration levels of the test control signal shall be within +6/-3 dB of the specified values over the entire test frequency range. However deviations of -6 dB in the test control signal may be granted above 500 Hz. The cumulative bandwidth for this deviation shall not exceed 5 percent of the test frequency range (see Figure E-4). In no case shall the acceleration levels be less than 6 dB below the specified requirements. No deviation shall be granted for frequencies below 500 Hz. Tolerance levels in terms of dB are defined as:

$$\text{dB} = 20 \log (W_m/W_s)$$

where:

$W_m$  = measured acceleration level in g's.

$W_s$  = specified level in g's.

TABLE E-I. Vibration test profiles - vertical axis.

PROFILE 1		PROFILE 2		PROFILE 3		PROFILE 4		PROFILE 5	
1.80 G RMS		1.70 G RMS		2.17 G RMS		2.97 G RMS		2.32 G RMS	
FREQ (Hz)	PSD (G <sup>2</sup> /Hz)	FREQ (Hz)	PSD (G <sup>2</sup> /Hz)	FREQ (Hz)	PSD (G <sup>2</sup> /Hz)	FREQ (Hz)	PSD (G <sup>2</sup> /Hz)	FREQ (Hz)	PSD (G <sup>2</sup> /Hz)
5	0.0000	5	0.0000	5	0.0000	5	0.0000	5	0.0000
5	0.0038	5	0.0038	5	0.0044	5	0.0047	5	0.0038
24	0.0038	36	0.0038	48	0.0044	66	0.0047	90	0.0038
24	0.2179	36	0.2967	48	0.2279	66	0.4500	90	0.1079
30	0.2179	42	0.2967	60	0.2279	84	0.4500	120	0.1079
30	0.0038	42	0.0038	60	0.0044	84	0.0047	120	0.0038
48	0.0038	72	0.0038	96	0.0044	132	0.0047	180	0.0038
48	0.1110	72	0.0071	96	0.0355	132	0.0565	180	0.0548
60	0.1110	84	0.0071	120	0.0355	168	0.0565	240	0.0548
60	0.0038	84	0.0038	120	0.0044	168	0.0047	240	0.0038
72	0.0038	108	0.0038	144	0.0044	198	0.0047	270	0.0038
72	0.1112	108	0.0157	144	0.0490	198	0.0624	270	0.0129
90	0.0038	126	0.0157	180	0.0490	252	0.0624	360	0.0129
90	0.0038	126	0.0038	180	0.0044	252	0.0047	360	0.0038
500	0.0038	500	0.0038	500	0.0044	500	0.0047	500	0.0038
500	0.0000	500	0.0000	500	0.0000	500	0.0000	500	0.0000

TABLE E-II. Vibration test profiles - transverse axis.

PROFILE 1		PROFILE 2		PROFILE 3		PROFILE 4		PROFILE 5	
1.24 G RMS		1.63 G RMS		2.48 G RMS		2.94 G RMS		1.00 G RMS	
FREQ (Hz)	PSD (G <sup>2</sup> /Hz)	FREQ (Hz)	PSD (G <sup>2</sup> /Hz)	FREQ (Hz)	PSD (G <sup>2</sup> /Hz)	FREQ (Hz)	PSD (G <sup>2</sup> /Hz)	FREQ (Hz)	PSD (G <sup>2</sup> /Hz)
5	0.0000	5	0.0000	5	0.0000	5	0.0000	5	0.0000
5	0.0009	5	0.0009	5	0.0011	5	0.0012	5	0.0038
24	0.0009	36	0.0009	48	0.0011	66	0.0012	90	0.0038
24	0.0049	36	0.0083	48	0.0069	66	0.0176	90	0.1079
30	0.0049	42	0.0083	60	0.0069	84	0.0176	120	0.1079
30	0.0009	42	0.0009	60	0.0011	84	0.0012	120	0.0038
72	0.0009	72	0.0009	96	0.0011	132	0.0012	180	0.0038
72	0.0020	72	0.0033	96	0.0078	132	0.0036	180	0.0548
90	0.0020	86	0.0033	120	0.0078	168	0.0036	240	0.0548
90	0.0009	86	0.0009	120	0.0011	168	0.0012	240	0.0038
96	0.0009	100	0.0009	144	0.0011	198	0.0012	500	0.0038
96	0.0905	100	0.0013	144	0.0056	198	0.0033	500	0.0000
120	0.0905	126	0.0013	180	0.0056	252	0.0033		
120	0.0009	126	0.0009	180	0.0011	252	0.0012		
500	0.0009	144	0.0009	192	0.0011	264	0.0012		
500	0.0000	144	0.1810	192	0.2272	264	0.2172		
		168	0.1810	240	0.2272	336	0.2172		
		168	0.0009	240	0.0011	336	0.0012		
		500	0.0009	500	0.0011	500	0.0012		
		500	0.0000	500	0.0000	500	0.0000		

TABLE E-III. Vibration test profiles - longitudinal axis.

PROFILE 1		PROFILE 2		PROFILE 3		PROFILE 4		PROFILE 5	
1.25 G RMS		0.74 G RMS		3.09 G RMS		4.13 G RMS		3.22 G RMS	
FREQ (Hz)	PSD (G <sup>2</sup> /Hz)	FREQ (Hz)	PSD (G <sup>2</sup> /Hz)	FREQ (Hz)	PSD (G <sup>2</sup> /Hz)	FREQ (Hz)	PSD (G <sup>2</sup> /Hz)	FREQ (Hz)	PSD (G <sup>2</sup> /Hz)
5	0.0000	5	0.0000	5	0.0000	5	0.0000	5	0.0000
5	0.0009	5	0.0009	5	0.0011	5	0.0014	5	0.0011
24	0.0009	36	0.0009	48	0.0011	66	0.0014	90	0.0011
24	0.0467	36	0.0273	48	0.0252	66	0.0927	90	0.0250
30	0.0467	42	0.0273	60	0.0252	84	0.0927	120	0.0250
30	0.0009	42	0.0009	60	0.0011	84	0.0014	120	0.0011
48	0.0009	72	0.0009	96	0.0011	132	0.0014	180	0.0011
48	0.0043	72	0.0054	96	0.0033	132	0.0027	180	0.0027
60	0.0043	84	0.0054	120	0.0033	168	0.0027	240	0.0027
60	0.0009	84	0.0009	120	0.0011	168	0.0014	240	0.0011
72	0.0009	500	0.0009	144	0.0011	198	0.0014	270	0.0011
72	0.1086	500	0.0000	144	0.1780	198	0.1689	270	0.2107
90	0.1086			180	0.1780	252	0.1689	360	0.2107
90	0.0009			180	0.0011	252	0.0014	360	0.0011
500	0.0009			192	0.0011	264	0.0014	500	0.0011
500	0.0000			192	0.2353	264	0.3077	500	0.0000
				240	0.2353	336	0.3077		
				240	0.0011	336	0.0014		
				500	0.0011	500	0.0014		
				500	0.0000	500	0.0000		

TABLE E-IV. Reliability test vibration profiles - M109A6 vertical axis.

PROFILE 1		PROFILE 2		PROFILE 3		PROFILE 4		PROFILE 5	
1.14 G RMS		0.84 G RMS		1.42 G RMS		1.27 G RMS		0.99 G RMS	
FREQ (Hz)	PSD (G <sup>2</sup> /Hz)	FREQ (Hz)	PSD (G <sup>2</sup> /Hz)	FREQ (Hz)	PSD (G <sup>2</sup> /Hz)	FREQ (Hz)	PSD (G <sup>2</sup> /Hz)	FREQ (Hz)	PSD (G <sup>2</sup> /Hz)
5	0.00000	5	0.00000	5	0.00000	5	0.00000	5	0.00000
5	0.00143	5	0.00118	5	0.00167	5	0.00169	5	0.00144
24	0.00143	42	0.00118	54	0.00167	78	0.00169	102	0.00144
24	0.07972	42	0.01025	54	0.06447	78	0.06583	102	0.00989
36	0.07972	48	0.01025	72	0.06447	96	0.06583	120	0.00989
36	0.00143	48	0.00118	72	0.00167	96	0.00169	120	0.00144
48	0.00143	84	0.00118	108	0.00167	156	0.00169	204	0.00144
48	0.00950	84	0.00511	108	0.00617	156	0.00821	204	0.00966
71	0.00950	96	0.00511	144	0.00617	192	0.00821	240	0.00966
71	0.00143	96	0.00118	144	0.00167	192	0.00169	240	0.00144
73	0.00143	126	0.00118	162	0.00167	234	0.00169	306	0.00144
73	0.00232	126	0.00132	162	0.01483	234	0.00465	306	0.00274
108	0.00232	144	0.00132	215	0.01483	288	0.00465	360	0.00274
108	0.00143	144	0.00118	215	0.00167	288	0.00169	360	0.00144
500	0.00143	168	0.00118	217	0.00167	500	0.00169	500	0.00144
500	0.00000	168	0.00245	217	0.00700	500	0.00000	500	0.00000
		192	0.00245	288	0.00700				
		192	0.00118	288	0.00167				
		210	0.00118	500	0.00167				
		210	0.00430	500	0.00000				
		240	0.00430						
		240	0.00118						
		500	0.00118						
		500	0.00000						

TABLE E-V. Reliability test vibration profiles - M109A6 longitudinal axis.

PROFILE 1		PROFILE 2		PROFILE 3		PROFILE 4		PROFILE 5	
0.50 G RMS		0.43 G RMS		0.49 G RMS		0.61 G RMS		0.50 G RMS	
FREQ (Hz)	PSD (G <sup>2</sup> /Hz)	FREQ (Hz)	PSD (G <sup>2</sup> /Hz)	FREQ (Hz)	PSD (G <sup>2</sup> /Hz)	FREQ (Hz)	PSD (G <sup>2</sup> /Hz)	FREQ (Hz)	PSD (G <sup>2</sup> /Hz)
5	0.00000	5	0.00000	5	0.00000	5	0.00000	5	0.00000
5	0.00033	5	0.00033	5	0.00043	5	0.00051	5	0.00041
24	0.00033	42	0.00033	54	0.00043	72	0.00051	90	0.00041
24	0.01273	42	0.00066	54	0.00241	72	0.01938	90	0.00337
36	0.01273	48	0.00066	66	0.00241	84	0.01938	120	0.00337
36	0.00033	48	0.00033	66	0.00043	84	0.00051	120	0.00041
48	0.00033	84	0.00033	108	0.00043	144	0.00051	180	0.00041
48	0.00128	84	0.00103	108	0.00050	144	0.00072	180	0.00056
72	0.00128	96	0.00103	132	0.00050	168	0.00072	240	0.00056
72	0.00033	96	0.00033	132	0.00043	168	0.00051	240	0.00041
500	0.00033	500	0.00033	216	0.00043	500	0.00051	270	0.00041
500	0.00000	500	0.00000	216	0.00117	500	0.00000	270	0.00045
				264	0.00117			380	0.00045
				264	0.00043			380	0.00041
				500	0.00043			500	0.00041
				500	0.00000			500	0.00000

TABLE E-VI. Reliability test CUCV vibration profiles.

VERTICAL AXIS		LONGITUDINAL AXIS	
1.76 G RMS		0.4 G RMS	
FREQ (Hz)	PSD (G <sup>2</sup> /Hz)	FREQ (Hz)	PSD (G <sup>2</sup> /Hz)
5	0.00000	5	0.00000
5	0.02950	5	0.00387
7	0.06699	7	0.00878
8	0.03101	11	0.00449
9	0.00941	12	0.00460
12	0.00460	13	0.00923
13	0.00580	16	0.00342
19	0.00139	19	0.00273
26	0.00139	35	0.00427
30	0.00265	46	0.00158
36	0.00357	50	0.00188
42	0.00285	55	0.00053
47	0.00469	63	0.00101
51	0.00414	69	0.00087
57	0.01236	74	0.00027
59	0.00716	100	0.00099
62	0.01206	113	0.02202
80	0.00176	115	0.01634
100	0.00873	119	0.04099
112	0.11863	149	0.00025
115	0.08378	163	0.00099
119	0.19021	176	0.00050
135	0.00265	207	0.01443
149	0.00078	252	0.00015
157	0.00135	260	0.00022
168	0.06065	273	0.00005
180	0.00103	287	0.00508
197	0.00139	293	0.00005
209	0.01332	444	0.00005
213	0.01065	457	0.00037
219	0.01471	466	0.00005
250	0.00078	500	0.00005
262	0.00142	500	0.00000
262	0.00027		
281	0.00027		
287	0.00425		
293	0.00027		
453	0.00027		
457	0.00078		
462	0.00027		
500	0.00027		
500	0.00000		

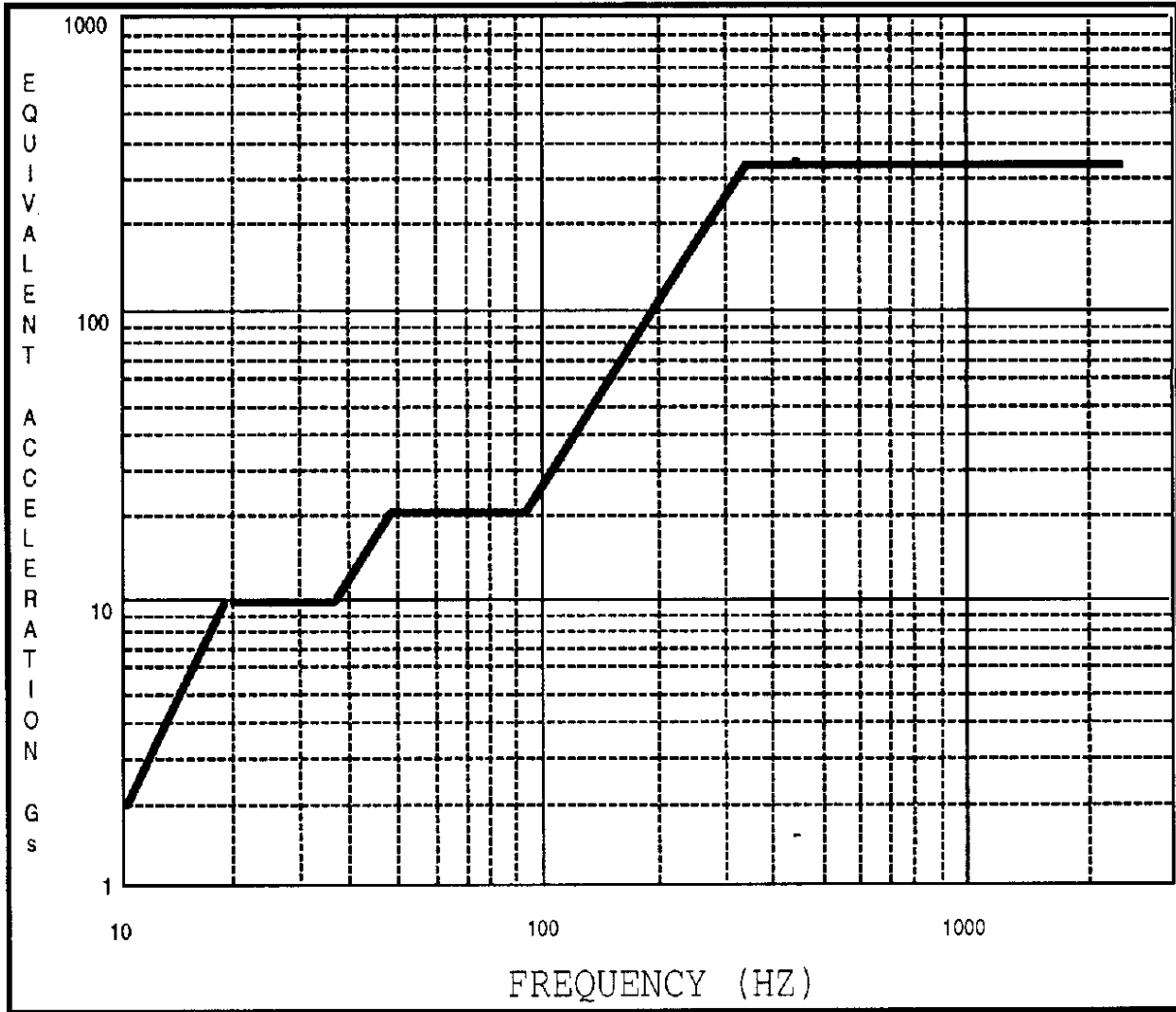

Spectrum Break Points

<u>FREQUENCY (HZ)</u>	<u>ACCELERATION (Gs)</u>
10.3	2
19.5	10
36.9	10
55.2	22
92.9	22
350.8	350
2359.7	350

FIGURE E-1. Gun firing shock spectrum - vertical axis.

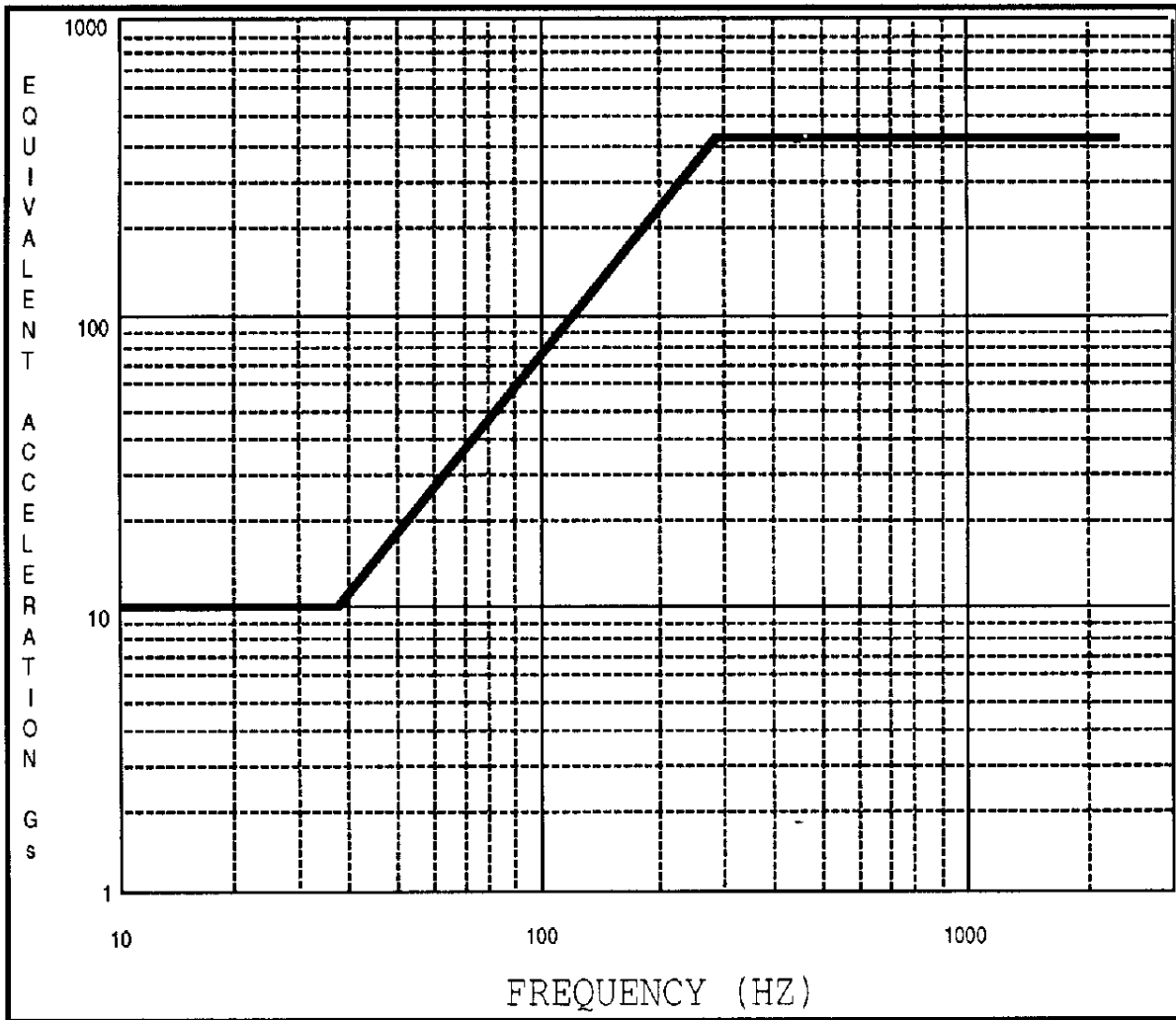

Spectrum Break Points

<u>FREQUENCY (HZ)</u>	<u>ACCELERATION (Gs)</u>
10.3	10
36.9	10
235.0	435
2359.7	435

FIGURE E-2. Gun firing shock spectrum - transverse axis.

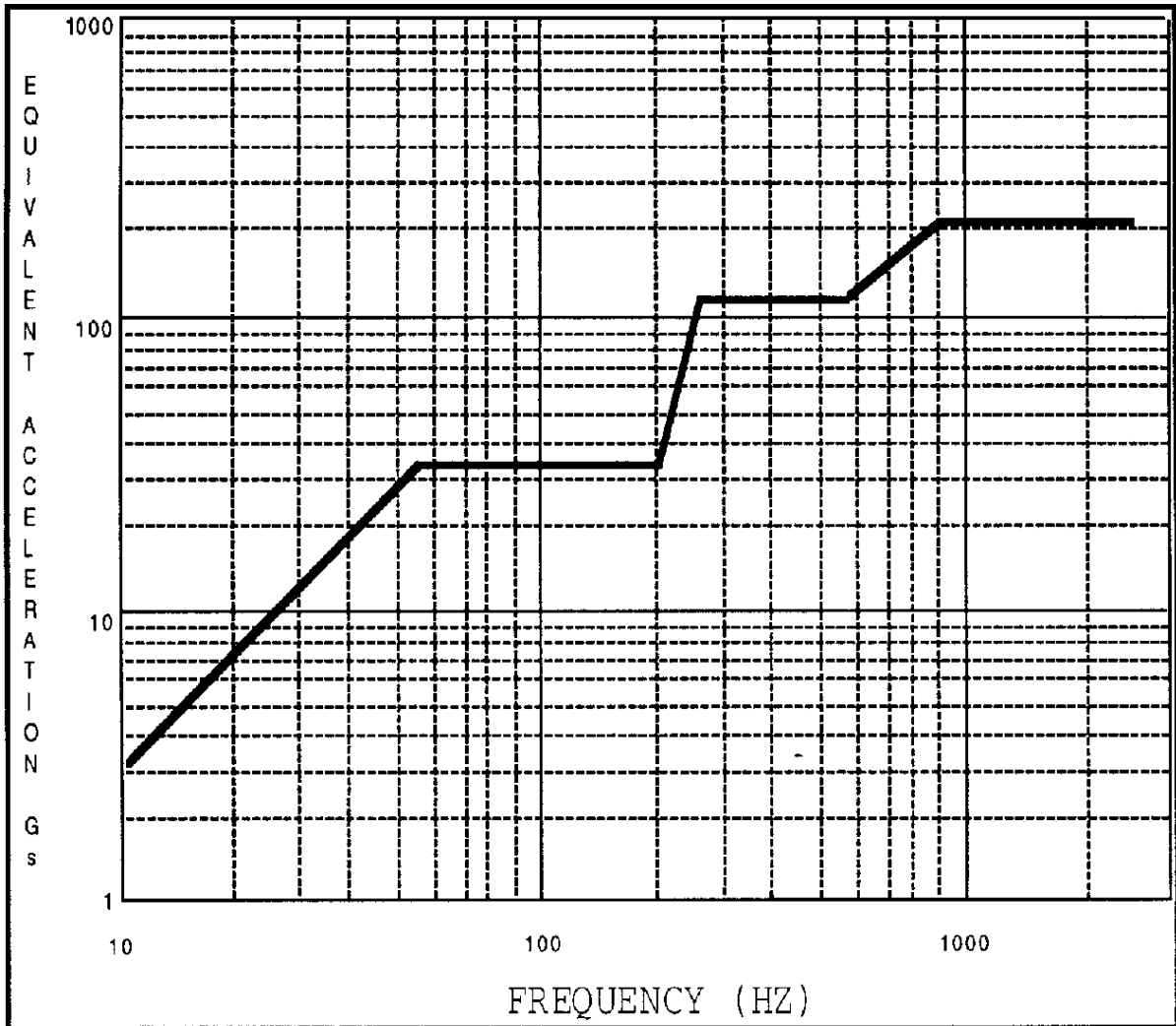

Spectrum Break Points

<u>FREQUENCY (HZ)</u>	<u>ACCELERATION (Gs)</u>
10.3	3.3
55.2	35
196.9	35
262.8	120
556.8	120
883.9	220
2359.7	220

FIGURE E-3. Gun firing shock spectrum - longitudinal axis.

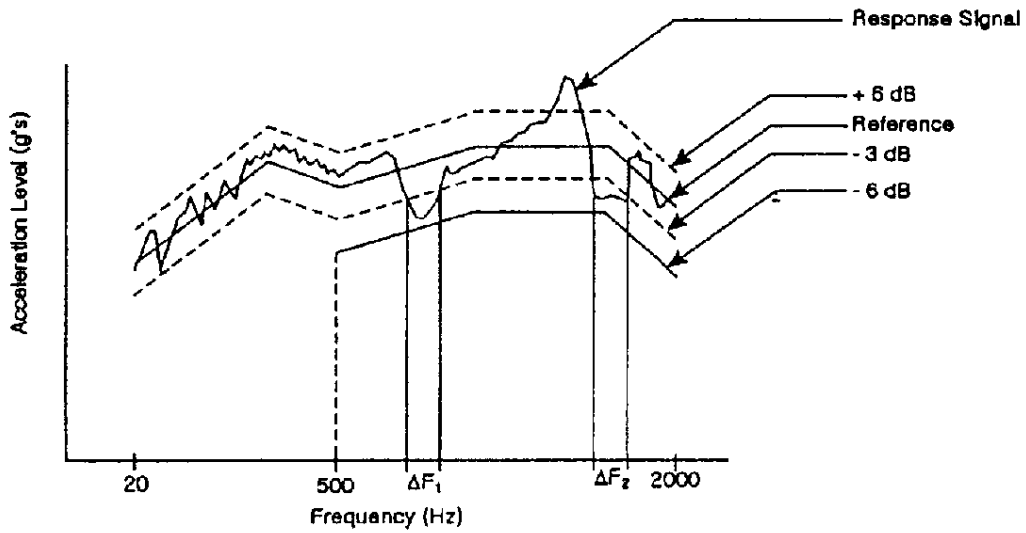

$\Sigma \Delta F_1 \leq 5\%$  of Test Band Width

FIGURE E-4. Gun firing shock tolerances.

## APPENDIX F

## MECHANICAL INTERFACE AND ENVELOPE

## F.1. SCOPE

F.1.1 Scope. This appendix is a mandatory part of this specification. The information herein is intended for compliance.

## F.2. APPLICABLE DOCUMENTS

F.2.1 General. The documents listed in this section are specified in section 3 of this appendix. This section does not include documents in other sections of this specification or recommended for additional information or as examples. While every effort has been made to ensure the completeness of this list, document users are cautioned that they must meet all specified requirements documents cited in section 3 of this appendix, whether or not they are listed.

F.2.2 Non-Government documents. The following document forms a part of this appendix to the extent specified herein. Unless otherwise specified, the issues of the documents which are DoD adopted are those listed in the issues of the DODISS cited in the solicitation. Unless otherwise specified, the issues of documents not listed in the DODISS are the issues of documents cited in the solicitation (see 6.2).

## AMERICAN NATIONAL STANDARDS INSTITUTE (ANSI)

ANSI/ASME Y 14.5      Dimensioning and Tolerancing

(Application for copies should be addressed to American National Standards Institute, 1430 Broadway, New York, NY 10018-3308.)

F.2.3 Order of precedence. In the event of a conflict between the text of this appendix and the references cited herein, the text of this appendix shall take precedence. Nothing in this appendix, however, supersedes applicable laws and regulations unless a specific exemption has been obtained.

## F.3. REQUIREMENTS

F.3.1 Mechanical interface and envelope. The mechanical interface and envelope of the DRUH, excluding connectors, shall be in accordance with Figures F-1 through F-6. Dimensions shall be maintained as specified.

F.3.1.1 BIT indicators and elapsed time meter. BIT indicators, DS-1 and DS-2, and the elapsed time meter, M-1, shall be located on the surface shown and shall be clearly labeled. No

illumination shall be visible from DS-1, DS-2, and M-1 during normal DRUH operation. DS-1, DS-2, and M-1 may be covered to block illumination. In which case access shall be provided for troubleshooting and maintenance.

F.3.1.2 Handles. Handles shall be provided for lifting the DRUH. Handles shall be located approximately as shown, consistent with good balance for lifting, removal and replacement of the DRUH. When not extended for use, handles shall: be within the overall DRUH envelope; not swing freely; and not interfere with access to DRUH connectors, mating connectors and mounting bolts.

F.3.2 Weight. The DRUH weight shall not exceed 55 pounds.

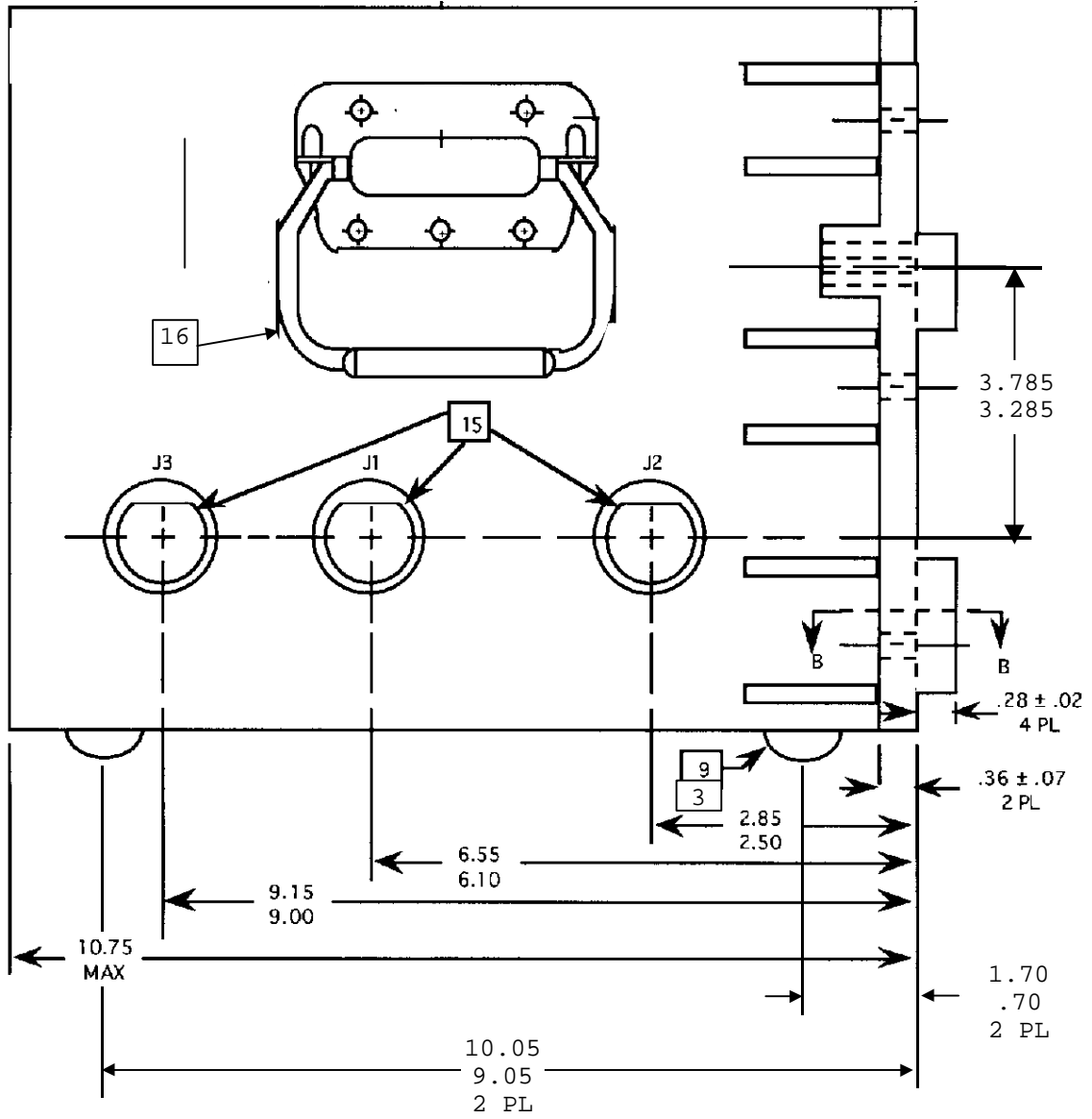

FIGURE F-1. DRUH right side.

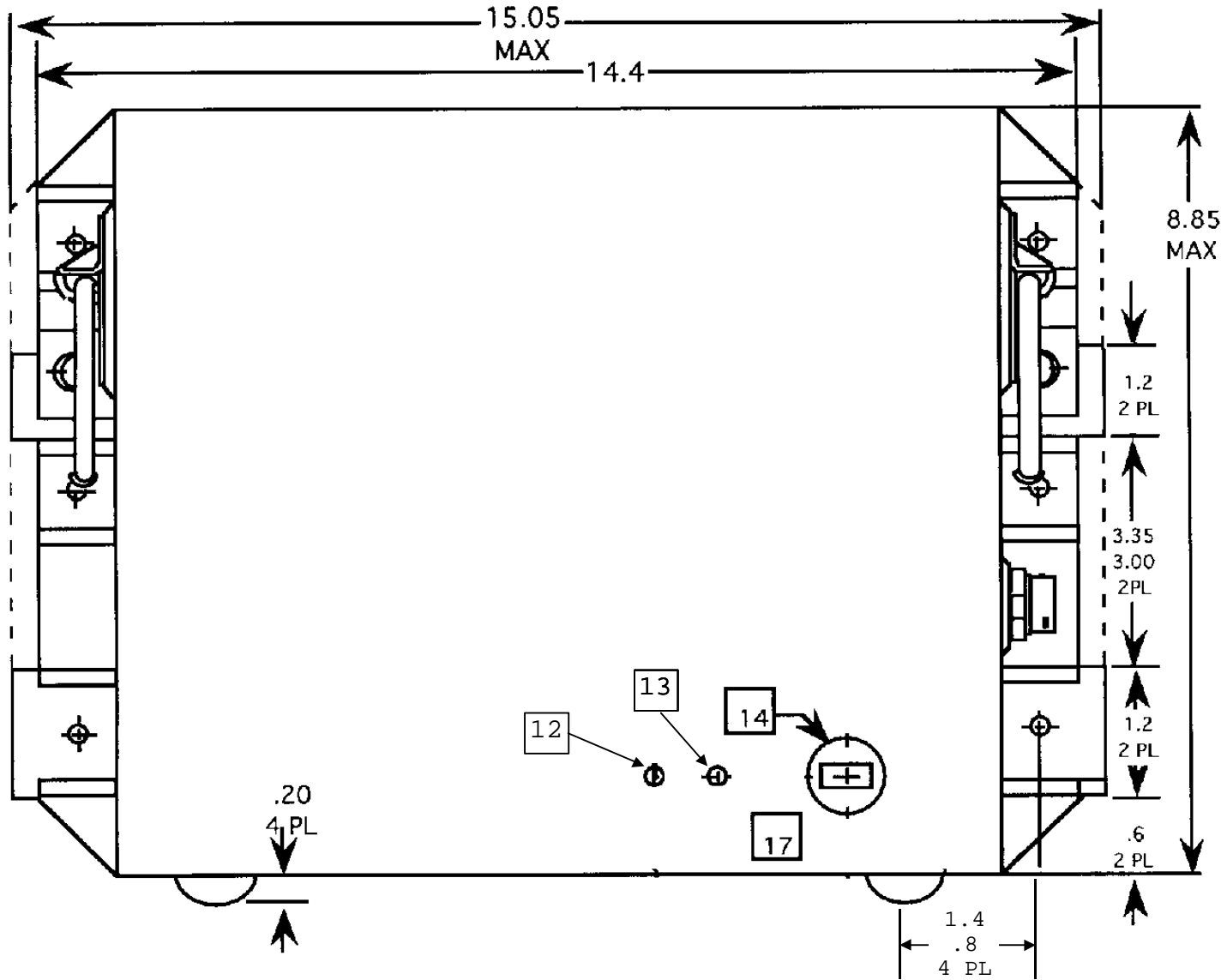

FIGURE F-2. DRUH front.

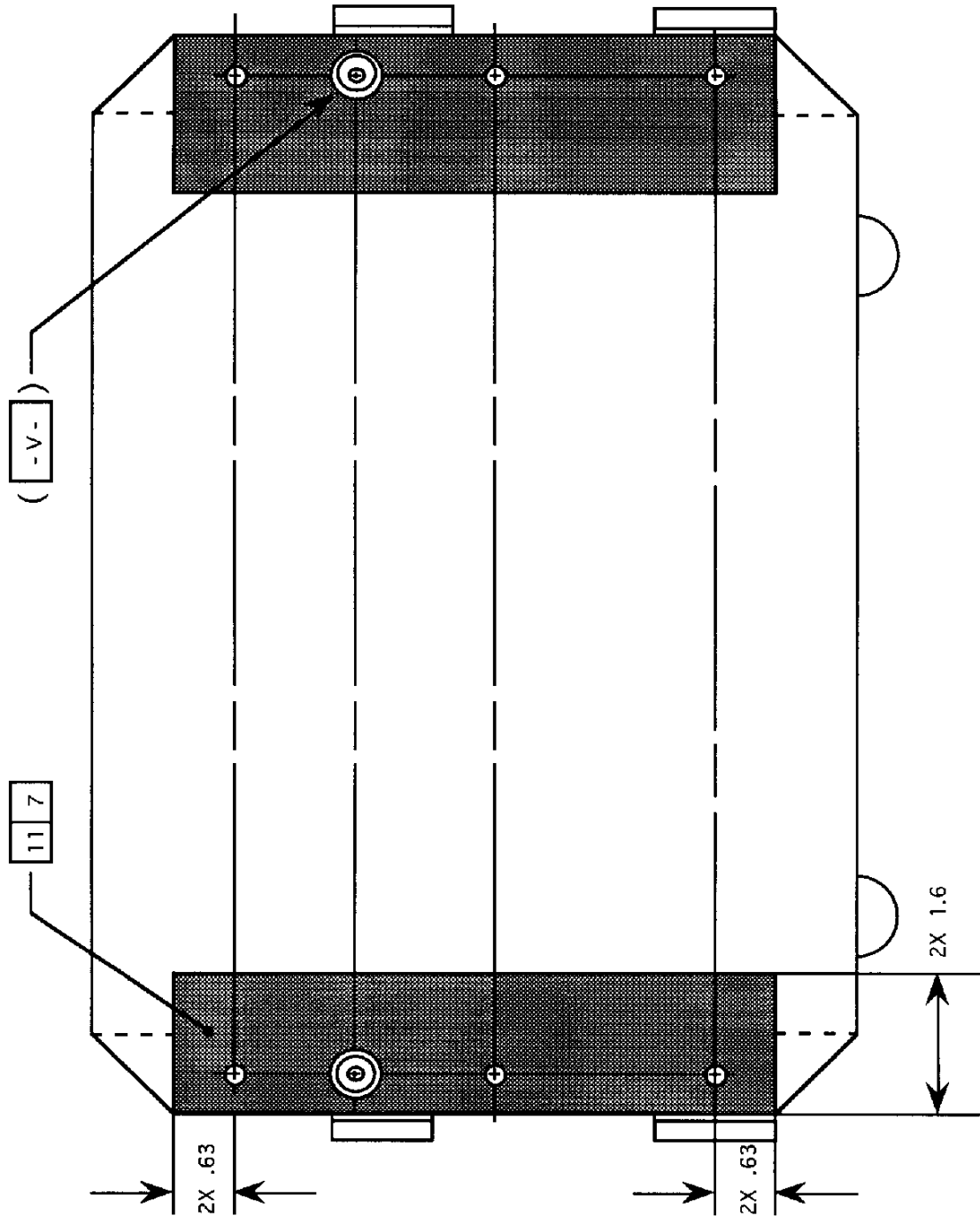

FIGURE F-3. DRUH back/mounting surface.

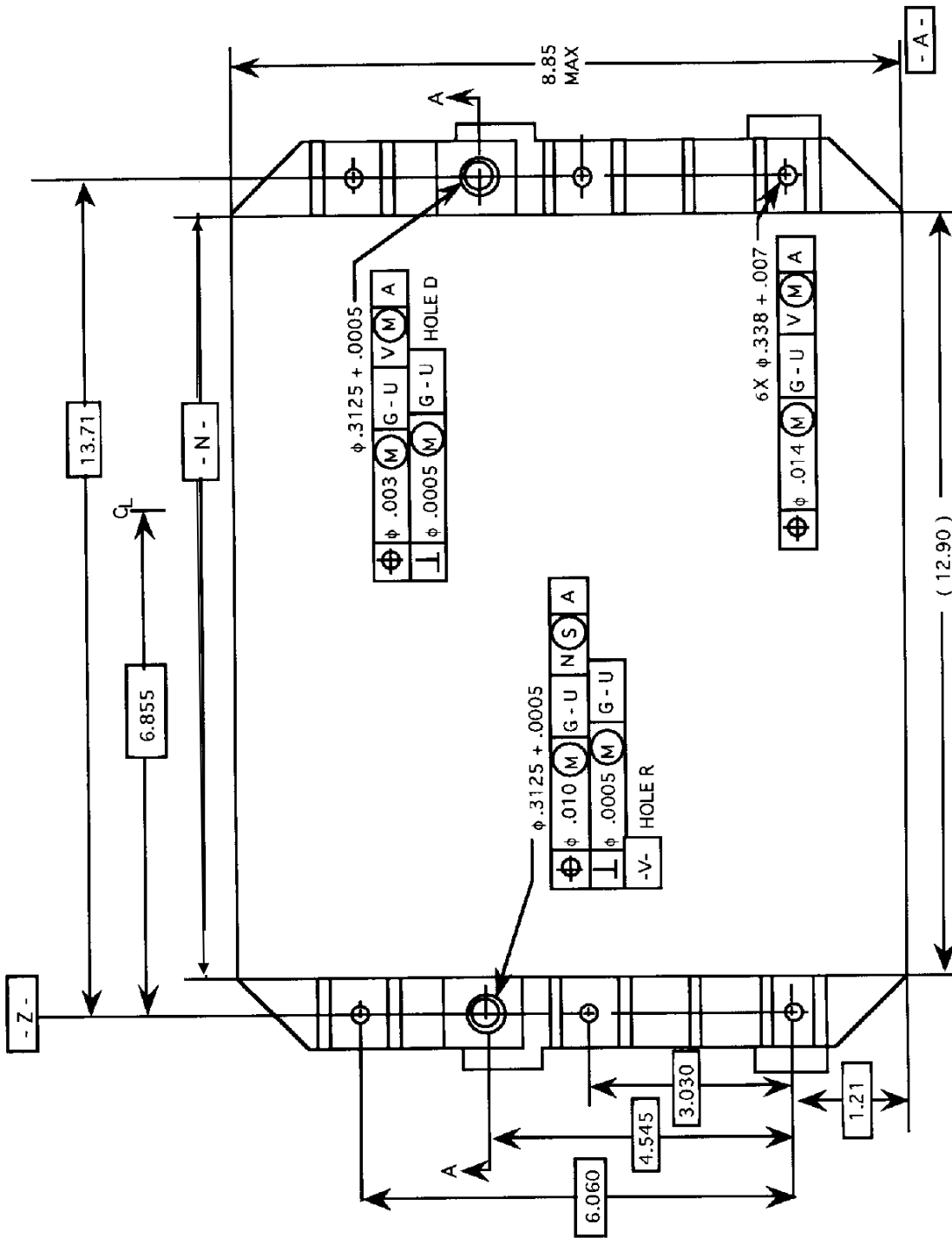

FIGURE F-4. DRUH hole location.

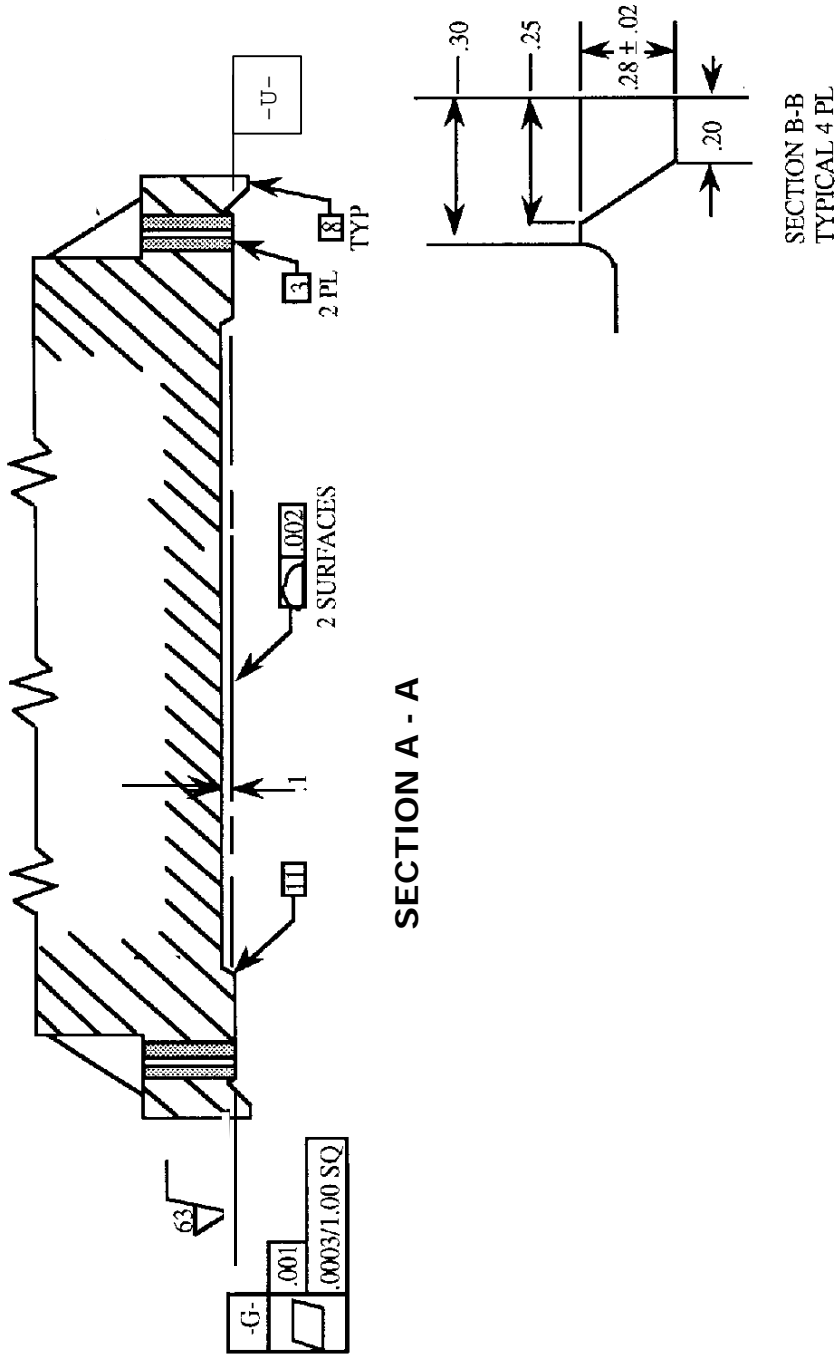

FIGURE F-5. Sections A-A and B-B

**NOTES:**

1. Dimensioning and tolerancing per ANSI/ASME Y 14.5M 1994.
2. Material: coefficient of expansion compatible with AL alloy 6061-T651/QQ-A-250/11.
3. Low wear, corrosion resistant material.
5. Dimensions are in inches.
6. Unless otherwise specified, tolerances on .X  $\pm$ .1, .XX  $\pm$ .01, .XXX  $\pm$ .005.
7. Shading indicates precision mounting surface.
8. Protective ridges shall not interfere with mounting or visual access to verify proper mating of DRUH and mount.
9. Shape of feet optional, height as specified
11. Mounting surfaces shall be free of paint for electrical bonding.
12. BIT Indicator DS-1 shall be labeled "PWR".
13. BIT Indicator DS-2 shall be labeled "DRU".
14. Elapsed time indicator M-1 shall be labeled "HOURS".
15. Connectors J1, J2 and J3 shall be installed with key locations as shown and shall be labeled "J1", "J2" and "J3", respectively.
16. See F.3.1.2 for handles.
17. Optional cover for DS-1, DS-2, and M-1 not shown (see F.3.1.1).

FIGURE F-6. Drawing notes.

## APPENDIX G

## GRID COORDINATES, ALTITUDE AND DATUMS

## G.1. SCOPE

G.1.1 Scope. This appendix provides the requirements for DRUH use of grid coordinates, altitude and datums. This appendix is a mandatory part of this specification. The information herein is intended for compliance.

## G.2. APPLICABLE DOCUMENTS

G.2.1 General. The documents listed in this section are specified in section 3 of this appendix. This section does not include documents in other sections of this specification or recommended for additional information or as examples. While every effort has been made to ensure the completeness of this list, document users are cautioned that they must meet all specified requirements documents cited in section 3 of this appendix, whether or not they are listed.

G.2.2 Government documents.

G.2.2.1 Other Government documents, drawings, and publications. The following other Government documents, drawings, and publications form a part of this specification to the extent specified herein. Unless otherwise specified, the issues are those in effect on the date of the solicitation.

## PUBLICATIONS

NIMA TR 8350.2	Department of Defense World Geodetic
Third Edition	System 1984, Its Definition and
4 July 1997	Relationships with Local Geodetic
	Systems

(Copies of NIMA TR 8350.2 may be obtained from Director, National Imagery and Mapping Agency, ATTN: ISDFR, Mail Stop D-17, 4600 Sangamore Road, Bethesda, MD 20816-5003. An electronic version may be found at <http://www.nima.mil>.)

G.2.3 Order of precedence. In the event of a conflict between the text of this document and the references cited herein, the text of this document shall take precedence. Nothing in this document, however, supersedes applicable laws and regulations unless a specific exemption has been obtained.

## G.3. REQUIREMENTS

G.3.1 Grid coordinates. The DRUH shall reference grid coordinates and grid azimuths to either the Universal Transverse Mercator (UTM) grid or British National Grid (BNG) grid as specified by the host in the Host (DRUH) Grid field of an ACCEPT POSITION or ACCEPT GEODETIC DATA command. The selected grid type shall be reported in the Host (DRUH) Grid field in messages that output position. The selected grid type shall be retained after a normal shutdown. Until changed, the DRUH shall use the last grid type entered. If the grid type wasn't previously initialized, or after an abnormal shutdown, the grid type shall default to UTM.

G.3.1.1 BNG. Horizontal position, in the BNG, is given by Easting and Northing. The BNG is in the Northern Hemisphere and has only one zone. When operating on the BNG, it is assumed that the boundaries are never crossed. The BNG is defined in the Ordnance Survey Information Leaflet, No. 72, March 1983.

For BNG, the DRUH shall ignore the values in the Extended Zone Number and Hemisphere & Zone of DRUH fields of the ACCEPT POSITION command. For BNG, the DRUH shall indicate a value of +0 in the Hemisphere and Zone field in messages that output grid positions.

BNG coordinates shall be valid when operating within the BNG area and on the Ordnance Survey of Great Britain 1936 (OGB-M) datum. BNG coordinates may be invalid and/or outside the specified range when the DRUH is operated outside the BNG area or on other datums. The DRUH is not required to perform area or datum validity checking for operating on the BNG.

G.3.1.1.1 BNG grid north. Grid north is offset from geodetic north by the grid convergence as described in Ordnance Survey Information Leaflet, No 72, March 1983.

G.3.1.2 UTM grid. Horizontal position, in the UTM grid, is given by the hemisphere, numerical grid zone, Easting and Northing. UTM grid coordinates can be referenced to several different spheroids (ellipsoids). The UTM grid is described in NIMA TM 8358.1 Datums, Ellipsoids, Grids, and Grid Reference Systems. Formulae for computing UTM grid coordinates are given in NIMA TM 8358.2 The Universal Grids: Universal Transverse Mercator (UTM) and Universal Polar Stereographic (UPS).

When the DRUH crosses the equator or a UTM zone or extended zone boundary, the DRUH shall automatically reference UTM coordinates and grid azimuth to the new hemisphere or zone and set ALERT DATA D6/3 (Boundary Crossed).

G.3.1.2.1 UTM grid north. Grid north is offset from geodetic north by the grid convergence as described in NIMA TM 8358.2. When operating in an extended UTM zone, grid convergence shall be calculated in terms of the present position in the extended zone, hemisphere, and reference spheroid.

G.3.1.2.2 UTM grid zone. The DRUH UTM grid zone is the numerical designation for the zone in which the DRUH is located. The numerical designation of the zone input at the start of a mission may represent the normal zone or the extended zone, depending on the coordinates available. When output is requested, the numerical designation of the zone in a message may represent the normal zone or the extended zone, depending on the coordinates associated with the zone.

G.3.1.2.2.1 Normal zone. When operating in the UTM grid and the Extended Zone Number in the last accepted ACCEPT POSITION command was  $\pm 61$ , or when the DRUH is outside the boundaries of a designated extended zone, the DRUH shall reference output UTM coordinates and grid azimuths to the normal zone.

G.3.1.2.2.2 Extended zone. When operating in the UTM grid and the Extended Zone Number in the last accepted ACCEPT POSITION command was in the range  $\pm 60$ , the DRUH shall reference output UTM coordinates and grid azimuths to the designated extended zone when its position is within the extended zone boundaries.

The boundaries for extended UTM zones are:

$$\lambda_E = \lambda_Z \pm 100,000/[R \times \text{Cos}(\phi)]$$

Where:

R = Ellipsoidal Radius of the Earth (meters)

$\lambda_E$  = Geographic Longitude of Extended Zone Boundary  
(radians)

$\lambda_Z$  = Geographic Longitude of the Normal Zone Boundary  
(radians)

$\phi$  = Geographic Latitude of the DRUH (radians)

G.3.1.3 Altitude. Altitude is the distance between the present DRUH position and the reference geoid (an equipotential surface of the earth approximated by mean sea level) measured along the local gravity vector (normal to the geoid). Altitude is positive when the DRUH is above the geoid and negative when below. When position is initialized from GPS data, the altitude reference shall be the WGS 84 geoid, which is described in NIMA TR 8350.2.

G.3.2 Datum reference. The DRUH shall reference horizontal positions and azimuths to the datum specified by the host in an ACCEPT POSITION or ACCEPT GEODETIC DATA command. The DRUH shall retain the datum reference after a normal shutdown. Until changed, the DRUH shall use the last datum that was entered. If the datum wasn't previously initialized or after an abnormal shutdown, the datum reference shall default to WGS 84.

G.3.2.1 Datum shifts. Datum shifts, except between WGS 72 and WGS 84, shall be implemented by a method that provides results equivalent to the standard Molodensky datum transformation formulas specified in NIMA TR 8350.2. Datum shifts between WGS 72 and WGS 84 shall be implemented by a method that provides results equivalent to the formulae specified in NIMA TR 8350.2.

G.3.2.2 Pre-programmed datums. The DRUH shall support at least 60 pre-programmed datums. The data associated with pre-programmed datums shall not be alterable in normal DRUH operation but shall be reprogrammable via the reprogramming interface(s). The DRUH shall utilize the pre-programmed datums listed for reference numbers 1 through 60 in Table G-I.

G.3.2.3 User defined datums. Upon receipt of a valid ACCEPT USER DATUM command, the DRUH shall store, as a user defined datum, and pass to the GPS receiver datum parameters for one of two user defined datums (USER1 or USER2). The ACCEPT USER DATUM command shall be invalid if: any data element is outside the allowable range limits; the DATUM ID Code is the same as the ID Code for any of the pre-programmed datums; or the User Datum Validity character indicates "data not valid". If an ACCEPT USER DATUM command is determined to be invalid, the DRUH shall reject the command and set ALERT DATA D5/2 (Invalid Data Received).

DRUH user defined datum parameters shall be retained after shutdown. Entry of user defined datum data shall be independent of the current datum selection. If a user defined datum is currently in use and the parameter values for that datum are updated, the new values shall not be used until that user defined datum has been reselected via an ACCEPT POSITION or ACCEPT GEODETIC DATA command.

G.3.2.4 DRUH/GPS datum compatibility. Upon initialization of the GPS receiver or update of the GPS USER datums: the DRUH shall request and store the GPS USER1 and USER2 datum parameters. When an ACCEPT POSITION or ACCEPT GEODETIC DATA command, which requires a datum change of the GPS datum, has been accepted: the DRUH shall pass the new Datum ID to the GPS receiver.

The DRUH shall determine if it and the GPS receiver are using the same Datum ID codes or, if USER1 or USER2 is being used, the same values for datum parameters. If the DRUH determines that the datums are not the same, ALERT DATA D1/6 (Datums Do Not Agree) shall be set.

### G.3.3 Datum data elements.

G.3.3.1 Datum ID. For input and output, a datum identifier (ID) consisting of six ASCII characters shall identify the datum. The datum ID shall be left justified in the data field. Should the ID have fewer than six characters, the field shall be right filled with ASCII spaces. Valid IDs for pre-programmed datums shall be as listed in Table G-I for reference numbers 1 through 60. IDs for DRUH user defined datums shall be as entered by the host. The allowable ASCII characters shall be A-Z, a-z, -, 0-9, and space.

G.3.3.2 Ellipsoid parameters. Ellipsoid parameters are given by the differences between the WGS 84 and local ellipsoid semi-major axes ( $\Delta a$ ) and flattening ( $\Delta f$ ). The differences are computed as WGS 84 minus the local ellipsoid.  $\Delta f$  is scaled times  $10^7$ . Ellipsoid parameters for pre-programmed datums shall be as listed in Table G-I. The Semi-major Axis ( $a$ ) and Inverse Flattening ( $1/f$ ) for the WGS 84 ellipsoid are 6378137 meters and 298.257223563, respectively.

G.3.3.3 Origin offsets. Origin offsets are given by the differences between the WGS 84 and local datum ellipsoid centers in the WGS 84 coordinate frame in three axes ( $\Delta X$ ,  $\Delta Y$ ,  $\Delta Z$ ). The differences are computed as WGS 84 minus the local system. Origin offsets for pre-programmed datums shall be as listed in Table G-I.

G.3.3.4 Datum descriptor. The datum consists of 16 ASCII characters. The datum descriptor shall be left justified in the data field. Should the descriptor have fewer than 16 characters, the field shall be right filled with ASCII spaces. Descriptors for pre-programmed datums shall be as listed in Table G-I for reference numbers 1 through 60. Descriptors for DRUH user defined datums shall be as entered by the host. The allowable ASCII characters shall be A-Z, a-z, -, 0-9, and space.

G.3.3.5 WGS 72. Table G-I does not contain all parameters needed to implement WGS 72. They are provided in NIMA-TR-8350.2.

G.3.4 Datum data output. When requested by the host, the DRUH shall output datum data for a designated datum reference number. Data for reference numbers 1 through 60 shall be for the corresponding pre-programmed datums specified in Table G-I. Data for reference number 0 shall be for the datum currently used by the DRUH. Data for reference numbers 61 and 62 shall be for DRUH user defined datums 1 and 2, respectively. If DRUH user datum parameters weren't previously entered, the DRUH shall output the default values listed in Table G-I. Data for reference numbers 63 and 64 shall be for the GPS receiver user defined datums 1 and 2, respectively. GPS user datum data shall not be retained after shutdown. GPS user datum data shall be retrieved during receiver initialization and after update by the DRUH. If GPS user datum data isn't available, the DRUH shall output the default values listed in Table G-I.

TABLE G-I Datums.

Ref No.	ID	Reference Ellipsoid Parameters			Origin Offsets (meters)			16 Character Datum Descriptor
		Name	$\Delta a(m)$	$\Delta fx10E7$	$\Delta X$	$\Delta Y$	$\Delta Z$	
* 0	WGD	WGS 84	0.	0.	0.	0.	0.	WGS-84
1	ARF-M	Clark 1880	-112.145	-547.507	-143.	-90.	-294.	ARC 1950
2	ARS	Clark 1880	-112.145	-547.507	-160.	-6.	-302.	ARC 1960
3	AUA	Australian National	-23.	-0.812	-133.	-48.	148.	Australia Geo 66
4	AUG	Australian National	-23.	-0.812	-134.	-48.	149.	Australia Geo 84
5	BOO	International	-251.	-141.927	307.	304.	-318.	Bogota Obsrvtory
6	CAI	International	-251.	-141.927	-148.	136.	90.	Campo Inchauspe
7	CAP	Clark 1880	-112.145	-547.507	-136.	-108.	-292.	Cape
8	CGE	Clark 1880	-112.145	-547.507	-263.	6.	431.	Carthage
9	CHI	International	-251.	-141.927	175.	-38.	113.	Chatam
10	CHU	International	-251.	-141.927	-134.	229.	-29.	Chua Astro
11	COA	International	-251.	-141.927	-206.	172.	-6.	Corrego Astro
12	EUR-A	International	-251.	-141.927	-87.	-96.	-120.	Euro50-West Euro
13	EUR-E	International	-251.	-141.927	-104.	-101.	-140.	Eiro50-Cyprus
14	EUR-F	International	-251.	-141.927	-130.	-117.	-151.	Euro50-Egypt
15	EUR-H	International	-251.	-141.927	-117.	-132.	-164.	Euro50-Iran
16	EUR-J	International	-251.	-141.927	-97.	-88.	-135.	Euro50-Sicily
17	EUS	International	-251.	-141.927	-86.	-98.	-119.	European 1979
18	FAH	Clark 1880	-112.145	-547.507	-346.	-1.	224.	Ohman
19	GAA	International	-251.	-141.927	-133.	-321.	50.	Gan 1970
20	GEO	International	-251.	-141.927	84.	-22.	209.	Geodetic Dtm 49
21	HJO	International	-251.	-141.927	-73.	46.	-86.	Hjorsey 1955
22	INF-A	Everest	860.655	283.614	217.	823.	299.	India 54 - Thai
23	IND-I	Everest	835.757	283.614	295.	736.	257.	India-Ind/Nepal
24	IRL	Modified Airy	796.811	119.600	506.	-122.	611.	Ireland 1965
25	KEA	Modified Everest	832.937	283.614	-11.	851.	5.	Kertau 1948
26	LIB	Clark 1880	-112.145	-547.507	-90.	40.	88.	Liberia 1964
27	LUZ-A	Clark 1866	-69.4	-372.646	-133.	-77.	-51.	Luzon
28	MAS	Bessel 1841	739.845	100.375	639.	405.	60.	Massawa
29	MER	Clark 1880	-112.145	-547.507	31.	146.	47.	Merchich
30	MIN-B	Clark 1880	-112.145	-547.507	-92.	-93.	122.	Minna-Nigeria

TABLE G-1 Datums. (continued)

Ref No.	ID	Reference Ellipsoid Parameters			Origin Offsets			16 Character Datum Descriptor
		Name	$\Delta a$ (m)	$\Delta fx10E7$	$\Delta X$ (m)	$\Delta Y$ (m)	$\Delta Z$ (m)	
31	NAH-C	Clark 1880	-112.145	-547.507	-243.	-192.	477.	Nahrwan
32	NAR	GRS 80	0.	0.000	0.	0.	0.	North Amer 1983
33	NAS-C	Clark 1866	-69.4	-372.646	-8.	160.	176.	No Amer-CONUS
34	NAS-D	Clark 1866	-69.4	-372.646	-5.	135.	172.	No Amer-Alaska
35	NAS-E	Clark 1866	-69.4	-372.646	-10.	158.	187.	No Amer-Canada
36	NAS-N	Clark 1866	-69.4	-372.646	0.	125.	194.	No Amer-Cent Am
37	OEG	Helmert 1906	-63.	4.808	-130.	110.	-13.	Old Egyptian
38	OGB-M	Airy	573.604	119.600	375.	-111.	431.	Ord Surv GrBR 36
39	OHA-M	Clark 1866	-69.4	-372.646	61.	-285.	-181.	Old Hawaiian
40	PIT	International	251.	-141.927	185.	165.	42.	Pitcairn 1967
41	QAT	International	-251.	-141.927	-128.	-283.	22.	Qatar National
42	QUO	International	251.	-141.927	164.	138.	-189.	Qornog
43	SAN-M	South American 1969	-23.	-0.812	-57.	1.	-41.	South America 69
44	SCK	Bessel 1841	653.135	100.375	616.	97.	-251.	Schwarzeck
45	TIL	Everest	838.444	283.614	-679.	669.	-48.	Timbalai 1948
46	TOY-M	Bessel 1841	739.845	100.375	-148.	507.	685.	Tokyo
47	WGD	WGS-84	0.	0.	0.	0.	0.	WGS-84
48	WGS	WGS-72	2.0	0.312	0.	0.	4.5	WGS-72
49	ZAN	International	-251.	-141.927	-265.	120.	-358.	Zanderij
50-60		WGS-84	0.	0.	0.	0.	0.	
* 61			0.	0.	0.	0.	0.	DRUH User 1
* 62			0.	0.	0.	0.	0.	DRUH User 2
** 63	USER1		0.	0.	0.	0.	0.	GPS User 1
** 64	USER2		0.	0.	0.	0.	0.	GPS User 2

\* #0, #61 and #62 data are data stored at last shutdown. (Default values shown.)  
#0 data are updated by the host via ACCEPT POSITION or ACCEPT GEODETIC DATA  
commands. #61 and #62 data are updated by the host via ACCEPT USER DATUM command.

\*\* #63 and #64 data are initialized from the GPS receiver via User Datums Message,  
#5088. (Default values shown.)

Custodian  
Army-AR

Preparing activity  
Army-AR

(Project 1220-A368)

# STANDARDIZATION DOCUMENT IMPROVEMENT PROPOSAL

## INSTRUCTIONS

1. The preparing activity must complete blocks 1, 2, 3, and 8. In block 1, both the document number and revision letter should be given.
2. The submitter of this form must complete blocks 4, 5, 6, and 7, and send to preparing activity.
3. The preparing activity must provide a reply within 30 days from receipt of the form.

**NOTE:** This form may not be used to request copies of documents, nor to request waivers, or clarification of requirements on current contracts. Comments submitted on this form do not constitute or imply authorization to waive any portion of the referenced documents(s) or to amend contractual requirements.

<b>I RECOMMEND A CHANGE:</b>	1. DOCUMENT NUMBER <b>MIL-PRF-71185 (AR)</b>	2. DOCUMENT DATE (YYYYMMDD) <b>30 JULY 1999</b>
------------------------------	---	--

DOCUMENT TITLE  
**DYNAMIC REFERENCE UNIT HYBRID (DRUH)**

4. NATURE OF CHANGE (*Identify paragraph number and include proposed rewrite, if possible. Attach extra sheets as needed.*)

5. REASON FOR RECOMMENDATION

**6. SUBMITTER**

a. NAME ( <i>Last, First, Middle Initial</i> )	b. ORGANIZATION	
c. ADDRESS ( <i>Include Zip Code</i> )	d. TELEPHONE ( <i>Include Area Code</i> ) (1) Commercial (2) DSN ( <i>if applicable</i> )	7. DATE SUBMITTED (YYYYMMDD)

**8. PREPARING ACTIVITY**

a. NAME <b>U.S. Army TACOM-ARDEC Standardization Team</b>	b. TELEPHONE ( <i>Include Area Code</i> ) (1) Commercial (973) 724-5822	(2) DSN 880-5822
c. ADDRESS ( <i>Include Zip Code</i> ) Attn; AMSTA-AR-QAW-E Picatinny Arsenal, NJ 07806-5000	<b>IF YOU DO NOT RECEIVE A REPLY WITHIN 45 DAYS, CONTACT:</b> Defense Standardization Program Office (DLSC-LM) 8725 John J. Kingman Road, Suite 2533 Fort Belvoir, Virginia 22060-6221 Telephone (703) 767-6888 DSN 427-6888	